

IMS  
15.3.0

*Commands, Volume 1:  
IMS Commands A - M  
(2024-08-30 edition)*



**Note**

Before you use this information and the product it supports, read the information in [“Notices”](#) on page [915](#).

2024-08-30 edition.

This edition applies to IMS 15 (program number 5635-A06), IMS Database Value Unit Edition, V15.03.00 (program number 5655-DS5), IMS Transaction Manager Value Unit Edition, V15.03.00 (program number 5655-TM4), and to all subsequent releases and modifications until otherwise indicated in new editions.

© **Copyright International Business Machines Corporation 1974, 2022.**

US Government Users Restricted Rights – Use, duplication or disclosure restricted by GSA ADP Schedule Contract with IBM Corp.

---

# Contents

- About this information..... ix**
  - Prerequisite knowledge.....ix
  - How new and changed information is identified..... ix
  - How to read syntax diagrams.....ix
  - Accessibility features for IMS 15.3.....xi
  - How to send your comments..... xi
  
- Chapter 1. IMS command language overview..... 1**
  - How to enter IMS commands..... 2
    - IMS MFS 3270 master terminal format..... 2
    - Using Multiple Console Support (MCS) consoles.....4
    - Outstanding reply numbers on z/OS consoles..... 5
    - Maximum length of command input from z/OS consoles..... 5
    - Multisegment command input..... 5
    - Using commands in a DBCTL environment.....7
    - Commands from an LU 6.2 device..... 7
    - Qualifying network LU names and commands..... 8
    - Issuing commands to the OM API..... 8
    - Batch SPOC format.....10
  - Command responses..... 11
    - Command responses to OM.....12
    - Responses to LU 6.2 devices..... 12
  - Sending messages to the z/OS system console.....13
  - Sending messages to the IMS master terminal..... 13
  - IMS terminal command examples..... 13
  - TSO SPOC command examples.....14
  - OM API command examples..... 15
  - IMS type-1 command format..... 15
  - IMS type-2 command format..... 20
  - Sending commands to the IMSplex..... 22
  - Command processing in an IMSplex..... 23
  - Command characteristics..... 24
  - Terminal security defaults for IMS type-1 commands..... 24
  - Commands recovered during emergency restart..... 26
  - Command processing in a dynamic resource definition environment..... 28
  - IMS type-1 commands logged to the secondary master terminal.....28
  - IMS type-1 commands supported from an AO application..... 29
  - Command security when using OM..... 34
  - Commands mirrored on an XRF alternate..... 35
  - Commands supported on the XRF alternate.....36
  - IMS type-1 commands supported from LU 6.2 devices and OTMA..... 38
  - Terminal security defaults for LU 6.2 devices and OTMA..... 39
  - Commands and keywords supported by the OM API..... 40
  - Equivalent IMS type-1 and type-2 commands..... 43
  - Equivalent IMS Connect WTOR, z/OS, and type-2 commands.....52
  
- Chapter 2. Command keywords and their synonyms..... 59**
  
- Chapter 3. Commands and keywords used in DBCTL..... 85**

|  |            |
|--|------------|
| <b>Chapter 4. Commands and keywords valid in DCCTL.....</b>      | <b>89</b>  |
| <b>Chapter 5. List of reserved words.....</b>                    | <b>93</b>  |
| <b>Chapter 6. IMS type-1 commands that are valid in ETO.....</b> | <b>97</b>  |
| <b>Chapter 7. /ACTIVATE command.....</b>                         | <b>99</b>  |
| <b>Chapter 8. /ALLOCATE command.....</b>                         | <b>101</b> |
| <b>Chapter 9. /ASSIGN command.....</b>                           | <b>103</b> |
| <b>Chapter 10. /BROADCAST command.....</b>                       | <b>121</b> |
| <b>Chapter 11. /CANCEL command.....</b>                          | <b>127</b> |
| <b>Chapter 12. /CHANGE commands.....</b>                         | <b>129</b> |
| /CHANGE APPC command.....  | 129        |
| /CHANGE CCTL command.....  | 130        |
| /CHANGE CPLOG command.....                                       | 132        |
| /CHANGE DESC command.....  | 132        |
| /CHANGE DIR MFS command.....                                     | 134        |
| /CHANGE FDR command.....   | 135        |
| /CHANGE LINK command.....  | 136        |
| /CHANGE NODE command.....  | 140        |
| /CHANGE SUBSYS command.....                                      | 143        |
| /CHANGE SURV command.....  | 145        |
| /CHANGE TRAN command.....  | 148        |
| /CHANGE UOR command.....   | 149        |
| /CHANGE USER command.....  | 151        |
| <b>Chapter 13. /CHECKPOINT command.....</b>                      | <b>153</b> |
| <b>Chapter 14. /CLSDST command.....</b>                          | <b>159</b> |
| <b>Chapter 15. /COMPT command.....</b>                           | <b>163</b> |
| <b>Chapter 16. /CQCHKPT command.....</b>                         | <b>167</b> |
| <b>Chapter 17. /CQQUERY command.....</b>                         | <b>169</b> |
| <b>Chapter 18. /CQSET command.....</b>                           | <b>173</b> |
| <b>Chapter 19. CREATE commands.....</b>                          | <b>175</b> |
| CREATE DB command.....   | 175        |
| CREATE DBDESC command.....                                       | 182        |
| CREATE IMSCON commands.....                                      | 188        |
| CREATE IMSCON TYPE(DATASTORE) command.....                       | 188        |
| CREATE IMSCON TYPE(IMSPLEX) command.....                         | 198        |
| CREATE IMSCON TYPE(PORT) command.....                            | 204        |
| CREATE LTERM command.....  | 214        |
| CREATE MSLINK command.....                                       | 218        |
| CREATE MSNAME command.....                                       | 226        |

|   |            |
|---|------------|
| CREATE MSPLINK command.....                         | 231        |
| CREATE OTMADESC command.....                        | 244        |
| CREATE PGM command.....                             | 254        |
| CREATE PGMDESC command.....                         | 265        |
| CREATE RTC command.....                             | 274        |
| CREATE RTCDESC command.....                         | 280        |
| CREATE TRAN command.....                            | 285        |
| CREATE TRANDESC command.....                        | 307        |
| <b>Chapter 20. /DBDUMP command.....</b>             | <b>329</b> |
| <b>Chapter 21. /DBRECOVERY command.....</b>         | <b>335</b> |
| <b>Chapter 22. /DELETE command.....</b>             | <b>343</b> |
| <b>Chapter 23. DELETE commands.....</b>             | <b>345</b> |
| DELETE DB command.....                              | 345        |
| DELETE DBDESC command.....                          | 352        |
| DELETE DEFN command.....                            | 358        |
| DELETE IMSCON commands.....                         | 375        |
| DELETE IMSCON TYPE(DATASTORE) command.....          | 375        |
| DELETE IMSCON TYPE(IMSPLEX) command.....            | 380        |
| DELETE IMSCON TYPE(PORT) command.....               | 384        |
| DELETE LE command.....                              | 389        |
| DELETE LTERM command.....                           | 395        |
| DELETE MSLINK command.....                          | 400        |
| DELETE MSNAME command.....                          | 404        |
| DELETE MSPLINK command.....                         | 410        |
| DELETE OTMADESC command.....                        | 414        |
| DELETE PGM command.....                             | 418        |
| DELETE PGMDESC command.....                         | 423        |
| DELETE RTC command.....                             | 428        |
| DELETE RTCDESC command.....                         | 432        |
| DELETE TRAN command.....                            | 437        |
| DELETE TRANDESC command.....                        | 444        |
| <b>Chapter 24. /DEQUEUE command.....</b>            | <b>451</b> |
| <b>Chapter 25. /DFSTCF LOAD command.....</b>        | <b>459</b> |
| <b>Chapter 26. /DIAGNOSE commands.....</b>          | <b>461</b> |
| /DIAGNOSE SET command .....                         | 461        |
| /DIAGNOSE SNAP command.....                         | 462        |
| <b>Chapter 27. /DISPLAY commands.....</b>           | <b>499</b> |
| Status and attributes for the /DISPLAY command..... | 501        |
| /DISPLAY ACT command.....                           | 514        |
| /DISPLAY AFFIN command.....                         | 529        |
| /DISPLAY AOITKN command.....                        | 531        |
| /DISPLAY APPC command.....                          | 532        |
| /DISPLAY AREA command.....                          | 534        |
| /DISPLAY ASMT command.....                          | 540        |
| /DISPLAY CCTL command.....                          | 549        |
| /DISPLAY CONV command.....                          | 552        |
| /DISPLAY CPLOG command.....                         | 556        |
| /DISPLAY CQS command.....                           | 557        |

|  |            |
|--|------------|
| /DISPLAY DB command.....                   | 557        |
| /DISPLAY DBD command.....                  | 567        |
| /DISPLAY DESC command.....                 | 568        |
| /DISPLAY FDR command.....                  | 569        |
| /DISPLAY FPV command.....                  | 570        |
| /DISPLAY HSSP command.....                 | 572        |
| /DISPLAY LINE command.....                 | 574        |
| /DISPLAY LINK command.....                 | 578        |
| /DISPLAY LTERM command.....                | 581        |
| /DISPLAY LUNAME command.....               | 585        |
| /DISPLAY MASTER command.....               | 590        |
| /DISPLAY MODIFY command.....               | 591        |
| /DISPLAY MSNAME command.....               | 603        |
| /DISPLAY NODE command.....                 | 605        |
| /DISPLAY OASN SUBSYS command.....          | 616        |
| /DISPLAY OLDS command.....                 | 617        |
| /DISPLAY OTMA command.....                 | 620        |
| /DISPLAY OVERFLOWQ command.....            | 625        |
| /DISPLAY PGM command.....                  | 628        |
| /DISPLAY POOL command.....                 | 630        |
| /DISPLAY PSB command.....                  | 648        |
| /DISPLAY PTERM command.....                | 650        |
| /DISPLAY Q command.....                    | 652        |
| /DISPLAY QCNT command.....                 | 656        |
| /DISPLAY RECOVERY command.....             | 660        |
| /DISPLAY RTCODE command.....               | 666        |
| /DISPLAY SHUTDOWN STATUS command.....      | 667        |
| /DISPLAY STATUS command.....               | 672        |
| /DISPLAY STRUCTURE command.....            | 679        |
| /DISPLAY SUBSYS command.....               | 680        |
| /DISPLAY SYSID TRANSACTION command.....    | 683        |
| /DISPLAY TIMEOVER command.....             | 684        |
| /DISPLAY TMEMBER command.....              | 685        |
| /DISPLAY TRACE command.....                | 697        |
| /DISPLAY TRAN command.....                 | 707        |
| /DISPLAY UOR command.....                  | 711        |
| /DISPLAY USER command.....                 | 715        |
| <b>Chapter 28. /END command.....</b>       | <b>723</b> |
| <b>Chapter 29. /ERESTART command.....</b>  | <b>725</b> |
| <b>Chapter 30. /EXCLUSIVE command.....</b> | <b>735</b> |
| <b>Chapter 31. /EXIT command.....</b>      | <b>737</b> |
| <b>Chapter 32. EXPORT command.....</b>     | <b>741</b> |
| <b>Chapter 33. /FORMAT command.....</b>    | <b>769</b> |
| <b>Chapter 34. /HOLD command.....</b>      | <b>771</b> |
| <b>Chapter 35. /IDLE command.....</b>      | <b>773</b> |
| <b>Chapter 36. IMPORT commands.....</b>    | <b>777</b> |
| IMPORT DEFN SOURCE(CATALOG) command.....   | 777        |

|   |            |
|---|------------|
| IMPORT DEFN SOURCE(REPO   RDDS) command.....        | 803        |
| <b>Chapter 37. INITIATE commands.....</b>           | <b>841</b> |
| INITIATE OLC command.....                           | 841        |
| INITIATE OLC error handling.....                    | 875        |
| INITIATE OLREORG command.....                       | 878        |
| <b>Chapter 38. /LOCK command.....</b>               | <b>889</b> |
| <b>Chapter 39. /LOG command.....</b>                | <b>895</b> |
| <b>Chapter 40. /LOOPTEST command.....</b>           | <b>897</b> |
| <b>Chapter 41. /MODIFY command.....</b>             | <b>899</b> |
| <b>Chapter 42. /MONITOR command.....</b>            | <b>905</b> |
| <b>Chapter 43. /MSASSIGN command.....</b>           | <b>907</b> |
| <b>Chapter 44. /MSVERIFY command.....</b>           | <b>911</b> |
| <b>Notices.....</b>                                 | <b>915</b> |
| Programming interface information.....              | 916        |
| Trademarks.....                                     | 916        |
| Terms and conditions for product documentation..... | 917        |
| IBM Online Privacy Statement.....                   | 917        |
| <b>Bibliography.....</b>                            | <b>919</b> |
| <b>Index.....</b>                                   | <b>921</b> |





## About this information

---

These topics provide command syntax and usage information for the IMS type-1 and type-2 commands / **ACTIVATE** through /**MSVERIFY**. The topics also describe the IMS command language and how to send commands to IMS in different environments. Information about all non-type-1 and non-type-2 IMS commands is in *IMS Version 15.3 Commands, Volume 3: IMS Component and z/OS Commands*.

This information is available in [IBM® Documentation](#).

## Prerequisite knowledge

---

Before using this information, you should have knowledge of either IMS Database Manager (DB) or IMS Transaction Manager (TM). You should also understand basic z/OS® and IMS concepts, your installation's IMS system, and have general knowledge of the tasks involved in project planning.

**Recommendation:** Before using this information, you should be familiar with the following resources:

- *IMS Version 15.3 Operations and Automation*
- *z/OS JES2 Commands*
- *z/OS JES3 Commands*
- *z/OS MVS™ System Commands*

To learn about z/OS, see [z/OS Basic Skills](#). For more resources, see [IBM Z Education and Training](#).

To learn about IMS, see the IBM Press publication *An Introduction to IMS*, the resources listed for [IBM Information Management System](#), and the variety of options available in [IBM Training](#).

## How new and changed information is identified

---

For most IMS library PDF publications, information that is added or changed after the PDF publication is first published is denoted by a character (revision marker) in the left margin. The *Program Directory* and *Licensed Program Specifications* do not include revision markers.

Revision markers follow these general conventions:

- Only technical changes are marked; style and grammatical changes are not marked.
- If part of an element, such as a paragraph, syntax diagram, list item, task step, or figure is changed, the entire element is marked with revision markers, even though only part of the element might have changed.
- If a topic is changed by more than 50%, the entire topic is marked with revision markers (so it might seem to be a new topic, even though it is not).

Revision markers do not necessarily indicate all the changes made to the information because deleted text and graphics cannot be marked with revision markers.

## How to read syntax diagrams

---

The following rules apply to the syntax diagrams that are used in this information:

- Read the syntax diagrams from left to right, from top to bottom, following the path of the line. The following conventions are used:
  - The >>--- symbol indicates the beginning of a syntax diagram.
  - The ---> symbol indicates that the syntax diagram is continued on the next line.
  - The >--- symbol indicates that a syntax diagram is continued from the previous line.
  - The --->< symbol indicates the end of a syntax diagram.



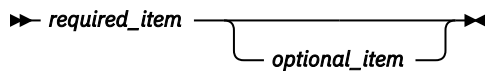

- In IMS, a b symbol indicates one blank position.
- Keywords, and their minimum abbreviations if applicable, appear in uppercase. They must be spelled exactly as shown. Variables appear in all lowercase italic letters (for example, *column-name*). They represent user-supplied names or values.
- Separate keywords and parameters by at least one space if no intervening punctuation is shown in the diagram.
- Enter punctuation marks, parentheses, arithmetic operators, and other symbols, exactly as shown in the diagram.
- Footnotes are shown by a number in parentheses, for example (1).

## Accessibility features for IMS 15.3

---

Accessibility features help a user who has a physical disability, such as restricted mobility or limited vision, to use information technology products successfully.

### Accessibility features

The following list includes the major accessibility features in z/OS products, including IMS 15.3. These features support:

- Keyboard-only operation.
- Interfaces that are commonly used by screen readers and screen magnifiers.
- Customization of display attributes such as color, contrast, and font size.

### Keyboard navigation

You can access IMS 15.3 ISPF panel functions by using a keyboard or keyboard shortcut keys.

For information about navigating the IMS 15.3 ISPF panels using TSO/E or ISPF, refer to the *z/OS TSO/E Primer*, the *z/OS TSO/E User's Guide*, and the *z/OS ISPF User's Guide Volume 1*. These guides describe how to navigate each interface, including the use of keyboard shortcuts or function keys (PF keys). Each guide includes the default settings for the PF keys and explains how to modify their functions.

### Related accessibility information

Online documentation for IMS 15.3 is available in IBM Documentation.

### IBM and accessibility

See the *IBM Human Ability and Accessibility Center* at [www.ibm.com/able](http://www.ibm.com/able) for more information about the commitment that IBM has to accessibility.

## How to send your comments

---

Your feedback is important in helping us provide the most accurate and highest quality information. If you have any comments about this or any other IMS information, you can take one of the following actions:

- Submit a comment by using the DISQUS commenting feature at the bottom of any [IBM Documentation](#) topic.
- Send an email to [imspubs@us.ibm.com](mailto:imspubs@us.ibm.com). Be sure to include the book title.
- Click the **Contact Us** tab at the bottom of any [IBM Documentation](#) topic.

To help us respond quickly and accurately, please include as much information as you can about the content you are commenting on, where we can find it, and what your suggestions for improvement might be.

---

# Chapter 1. IMS command language overview

You can use the IMS master terminal, TSO SPOC, or the OM API to receive messages, issue commands, and receive command responses.

IMS supports two types of command formats to manage IMS systems and resources: IMS type-1 commands and IMS type-2 commands.

You can enter IMS type-1 commands through multiple terminal types and applications, and most can be entered through the OM API. IMS type-2 commands can be entered only from the OM API. z/OS commands can be entered only from a z/OS system console, not from an IMS master terminal.

## IMS type-1 commands

IMS type-1 commands can be entered from IMS terminals, master terminals, system consoles, EMCS consoles, IMS application programs through CMD calls and ICMD calls, and LU 6.2 and OTMA applications. IMS type-1 commands are in the original or classic IMS command syntax, and are preceded by a command recognition character if the command is issued from one of these interfaces.

Most IMS type-1 commands can also be entered from the OM API, but not all of them. If the command is issued from the OM API, the command recognition character is optional. Use RACF® or an equivalent security product for security checking. IMS type-1 command output from the OM API is in message format within an XML tag structure.

## IMS type-2 commands

IMS type-2 commands can be entered only from the OM API, not from a master or remote terminal. Either RACF (or an equivalent security product) or command security can be used for security checking. IMS type-2 command output is in XML tag structure.

Both IMS type-1 commands and type-2 commands can be entered from the OM API (for example, TSO SPOC or user-written programs using OM API).

Subsections:

- [“How to enter IMS commands” on page 2](#)
- [“Command responses” on page 11](#)
- [“Sending messages to the z/OS system console” on page 13](#)
- [“Sending messages to the IMS master terminal” on page 13](#)
- [“IMS terminal command examples” on page 13](#)
- [“TSO SPOC command examples” on page 14](#)
- [“OM API command examples” on page 15](#)
- [“IMS type-1 command format” on page 15](#)
- [“Command processing in an IMSplex” on page 23](#)
- [“IMS type-2 command format” on page 20](#)
- [“Command characteristics” on page 24](#)
- [“Terminal security defaults for IMS type-1 commands” on page 24](#)
- [“Commands recovered during emergency restart” on page 26](#)
- [“IMS type-1 commands logged to the secondary master terminal” on page 28](#)
- [“Command security when using OM” on page 34](#)
- [“IMS type-1 commands supported from an AO application” on page 29](#)
- [“Commands mirrored on an XRF alternate” on page 35](#)
- [“Commands supported on the XRF alternate” on page 36](#)
- 
-

- [“IMS type-1 commands supported from LU 6.2 devices and OTMA” on page 38](#)
- [“Terminal security defaults for LU 6.2 devices and OTMA” on page 39](#)
- [“Commands and keywords supported by the OM API” on page 40](#)
- [“Equivalent IMS type-1 and type-2 commands” on page 43](#)

#### **Related reference**

[“IMS type-1 command format” on page 15](#)

This section describes the general format for an IMS type-1 command.

[“IMS type-2 command format” on page 20](#)

IMS type-2 commands use a different format from the format used by IMS type-1 commands.

[“Commands and keywords supported by the OM API” on page 40](#)

Some IMS commands are supported by the OM API.

## **How to enter IMS commands**

---

These topics describe how to enter various types of IMS commands.

Subsections:

- [“IMS MFS 3270 master terminal format” on page 2](#)
- [“Using Multiple Console Support \(MCS\) consoles” on page 4](#)
- [“Outstanding reply numbers on z/OS consoles” on page 5](#)
- [“Maximum length of command input from z/OS consoles” on page 5](#)
- [“Multisegment command input” on page 5](#)
- [“Using commands in a DBCTL environment” on page 7](#)
- [“Commands from an LU 6.2 device” on page 7](#)
- [“Qualifying network LU names and commands” on page 8](#)
- [“Issuing commands to the OM API” on page 8](#)
- [“Batch SPOC format” on page 10](#)

#### **Related concepts**

[REXX SPOC API \(Operations and Automation\)](#)

[Controlling IMS with the TSO SPOC application \(Operations and Automation\)](#)

## **IMS MFS 3270 master terminal format**

You can use the IMS master terminal for messages, commands, and responses.

The IMS master terminal consists of two components of the IBM 3270 Information Display System:

- A 3270 display screen with 24 lines by 80 columns; a screen size of 1920 characters
- A 3270 printer

All IMS system messages for the master terminal are sent to the display screen.

The format of the display screen is normally divided into five areas:

- System status area (line 1)
- Message area (lines 2-10)
- Display area (lines 12-21)
- Warning message area (line 22)
- User input area (lines 23 and 24)

The following figure shows the format of the master terminal display screen.

```

yy/mm/dd hh:mm:ss                               IMS id
Message Area (9 lines)
-----
Display Area (10 lines)
Warning Message Area (1 line)                   PASSWORD:
User Input Area (2 lines)

```

Figure 1. Master terminal format

The following figure shows the format of the master terminal display screen in an extended recovery facility (XRF) environment.

```

85/05/15 14:24:40  RSENAME: DFSRSENM  BACKUP  TRACKING IN PROGRESS  IMSA
Message Area (9 lines)
-----
Display Area (10 lines)
Warning Message Area (1 line)                   PASSWORD:
User Input Area (2 lines)

```

Figure 2. Master terminal format in XRF environment

## System status area

This area (line 1) displays the date, time, and IMS identifier:

### Date

The current date

### Time

The current time

### IMS Identifier

IMS system ID

If the system is XRF capable, the following information is also displayed on the status line:

### RSEname

Recoverable service element name

### System

ACTIVE or BACKUP (field is completed following the initialization phase)

### Phase

Blank or one of the following:

#### Initialization

Active or alternate system is in initialization phase

#### Synchronization

Alternate system processing SNAPQ checkpoint

#### Tracking in progress

Alternate system synchronized with active system and in the process of tracking active system

#### Takeover in progress

Alternate system in the process of taking over from active system

#### Awaiting I/O prevention

New active system is in I/O toleration mode and is awaiting completion of I/O prevention on the failing system prior to becoming a true active system

## Message area

This area (lines 2 through 10) displays IMS system messages, messages from other terminals and programs, and responses to IMS commands, except responses to a **/DISPLAY** command. If the message area is full and more output needs to be displayed, a warning message is sent. Press the PA1 key to receive more output. New data is displayed on the top line followed by a blank line to separate new data from old messages.

## Display area

This area (lines 12 through 21) displays the output from a **/DISPLAY** command. If the response to the command exceeds the size of the area, a warning message is sent.

## Warning message area

This area (line 22) can contain one of the following warning messages:

### **MASTER LINES WAITING**

A message being displayed in the message area has exceeded the available space and is only partially displayed.

### **MASTER MESSAGE WAITING**

The message area is full, and a message from another terminal or program is waiting to be displayed.

### **DISPLAY LINES WAITING**

The output of a **/DISPLAY** command exceeds the size of the display area.

### **USER MESSAGE WAITING**

A message requiring the screen to be formatted differently is waiting to be displayed.

In all cases, press the PA1 key to receive the waiting output.

The literal **PASSWORD** is followed by an unprotected field with the nondisplay attribute at the end of line 22.

## User input area

This area (lines 23 and 24) is used to enter IMS commands. It consists of two 79-character segments, so you can enter multisegment commands such as **/BROADCAST**, **/CHANGE**, **/RMxxxxxx**, and **/SSR**. For example, to send a message to all active terminals, enter **/BROADCAST ACTIVE** on line 23 and enter the message text on line 24. The cursor is initially positioned by IMS to line 23, your first input line.

## Using Multiple Console Support (MCS) consoles

You can enter IMS commands from Multiple Console Support (MCS) or Extended Multiple Console Support (E-MCS) consoles.

Use the **CMDMCS** keyword for the IMS, DBC, or DCC procedures during IMS system definition to enable commands to be entered from MCS or E-MCS consoles.

In a DB/DC environment, if Multiple Console is enabled (**CMDMCS** other than 'n' specified), IMS commands can be entered from an MCS or E-MCS console by prefixing the command by either the CRC or IMSID. For example, if the CRC is '#', a valid command would be **#DIS A**. If the IMSID is 'IMSP', a valid command would be **IMSPDIS A**.

Each segment of an IMS command must begin with one of the following:

- The command-recognition character for the IMS subsystem
- The IMS ID of the IMS subsystem

For multisegment commands, each segment, except the last, must end with the command recognition character or IMS ID followed by the ENTER key. The last segment must end with only the EOM (end-of-message, or ENTER) character.



You can send commands to all the IMS systems in an IMSplex by using an automated operations single-point-of-control (SPOC) application that sends commands and receives the responses to those commands through the Operations Manager (OM) application programming interface (API).

When you are using a Resource Manager (RM) structure in an IMSplex, it is best to issue commands to the Operations Manager (OM) through the TSO SPOC.

## Outstanding reply numbers on z/OS consoles

Outstanding reply numbers are used only on z/OS system consoles. They are used to pass input directly to IMS. Terminals defined to IMS do not use outstanding reply numbers.

As an example, IMS might display the following on the z/OS console:

```
*48 DFS996I *IMS READY*
```

To communicate with IMS through the z/OS system console, you must reply with the outstanding reply number (in this example, the number is 48). A reply might look like this:

```
R 48,/START DC
```

After IMS responds to the command, the next outstanding reply number is displayed with the DFS996I message, as follows:

```
DFS058I START COMMAND COMPLETED  
*49 DFS996I *IMS READY*
```

## Maximum length of command input from z/OS consoles

For single-segment commands that are entered from the z/OS console, the maximum character length (including command recognition characters) is 118.

This limit comes from the implementation of the WTOR macro.

## Multisegment command input

Multisegment commands require an EOS (end-of-segment) indicator for all segments preceding the last segment, and an EOM (end-of-message) indicator for the last segment.

The EOS and EOM will vary, depending on the type of terminal entering the command. For example, on the system console, EOS is indicated by the ENTER key and EOM is indicated by entering a period followed by the ENTER key.

The following are multisegment commands:

- **/ALLOCATE**
- **/BROADCAST**
- **/CHANGE**
- **/ERESTART**
- **/LOOPTEST**
- **/OPNDST**
- **/RMxxxxxx**
- **/SSR**

The period is used both as a delimiter for comments on IMS commands and as an EOM indicator for some terminal types. The following four examples illustrate the use of the period in both contexts.

If support for special characters is enabled in RACF and the last parameter of the **/OPNDST** command is a password, you must add a space before the period.

### ***Example 1 for multisegment commands***

System console entry:

```
24,/BRO MASTER. END OF DAY MESSAGE
25,I AM GOING HOME. PLEASE TAKE OVER.
```

Response on master terminal:

```
I AM GOING HOME. PLEASE TAKE OVER.
```

Explanation: The first input segment (reply 24) contains only the command and consists of a comment (END OF DAY MESSAGE) separated from the command itself (BRO MASTER) by a period. The second input segment (reply 25) consists of the data to be broadcast. The first period in segment 2 is part of the data and the second period in segment 2 is the EOM indicator for the system console.

### **Example 2 for multisegment commands**

System console entry:

```
26,/CHANGE DIRECT
27,ORY MFS. MODIFICATION.
```

Explanation: MODIFICATION in segment 2 is a comment and is separated from the command by the first period. The second period in segment 2 is the EOM indicator for the system console.

The above 2 segments are combined and the following is input to the command processor:

```
/CHANGE DIRECTORY MFS. MODIFICATION
```

### **Example 3 for multisegment commands**

System console entry:

```
28,/CHANGE LINK 1
29,2 3 FORCSESS.
```

Explanation: Certain forms of reply to the system console "outstanding reply" can compress out leading blanks from input segments. In example three, the command processed by the **/CHANGE** command processor would be: **/CHANGE LINK 12 3 FORCSESS**. To obtain the desired command, **/CHANGE LINK 1 2 3 FORCSESS**, one of the following forms of reply could be used:

```
R 29, '/CHANGE LINK 1'
R 30, ' 2 3 FORCSESS.'
```

or

```
29,/CHANGE LINK 1
30, 2 3 FORCSESS
```

### **Example 4 for multisegment commands**

LU2 or 3270 Display Terminal entry:

```
/FORMAT DFSM04
/BRO LTERM WTOR (eos)
this is segment 1 (eos)
this is segment 2 (eos)
this is segment 3 (eom)
```

Explanation: The remote terminal is first formatted by the **/FORMAT** command, where default format DFSM04 supports the input of 4 segments.

For LU2 and 3270 display terminals, enter a **/FORMAT DFSM04** command before entering the multisegment command.

## Using commands in a DBCTL environment

You can find examples of different contexts of using the supported commands in a Database Control (DBCTL) environment.

### Examples of using DBCTL commands

In a DBCTL environment, you can enter the command recognition character (slash or other character preceding the verb) or IMS ID, followed by the command. When you use a z/OS console, because there are no outstanding reply numbers for z/OS consoles, you must not enter any outstanding reply number in the command.

**Note:** The DFS996I outstanding reply number is not returned by DBCTL.

System console entry for single-segment command:

```
¢DIS DB PAYROLL
```

Explanation: ¢ is the command-recognition character for the DBCTL subsystem.

```
IMS1DIS DB PAYROLL
```

Explanation: IMS1 is the IMS ID for the DBCTL subsystem.

System console entry for multi-segment command:

```
/RMI DBRC='IC DBD(DEDBDD01) AREA (DD01AR0) ICDSN(FVT31.DEDBDD01.DD01  
AR0.IC.DUMMY1) ICDSN2/  
/(FVT31.DEDBDD01.DD01AR0.IC2.DUMMY1) HSSP'
```

Explanation: The first segment of the **/RMI** command has the command recognition character at the beginning of the segment and at the end of the segment, to indicate another segment follows. The last segment has the command recognition character at the beginning of the segment only.

### Related reference

[“Commands and keywords used in DBCTL” on page 85](#)

You can find the list of supported commands and keywords that are valid in the Database Control (DBCTL) environment. You can also find the links to the detailed information about the supported commands.

### Related information

[DFS996I \(Messages and Codes\)](#)

## Commands from an LU 6.2 device

To enter a command from an LU 6.2 device, allocate a conversation using an IMS command verb as the TPNAME.

The "/" must be included in the command word. The password option is not valid. (The password must be supplied as a part of the LU 6.2 ALLOCATE from the partner.) The normal LU 6.2 security provisions apply for this transaction.

**Restriction:** The APPC synchronization level of CONFIRM is ignored for commands from LU 6.2 devices.

The following three examples show the sequence of steps used to issue commands by allocating a synchronous conversation on an LU 6.2 device:

### Example 1 for commands from an LU 6.2 device

```
ALLOCATE  
  -LUNAME=luname of IMS  
  -TPNAME=/DISPLAY (Single segment command)  
SEND  
  -DATA=LTERM VA01 VA02.comments (Data after period treated as comments)  

```

```

RECEIVE (Get output for LTERM VA02)
RECEIVE (Get time stamp)
RC=DEALLOCATE

```

### **Example 2 for commands from an LU 6.2 device**

```

ALLOCATE
  -LUNAME=luname of IMS
  -TPNAME=/CHANGE (Multisegment command)
SEND
  -DATA=NODE (Can spread over several SENDs)
SEND
  -DATA=VAT02 ASR OFF.comments (Data after period treated as comments)
PREPARE_TO_RECEIVE
RECEIVE (Get DFS058 CHANGE COMMAND COMPLETED)
RC=DEALLOCATE

```

### **Example 3 for commands from an LU 6.2 device**

```

ALLOCATE
  -LUNAME=luname of IMS
  -TPNAME=/BROADCAST
SEND
  -DATA=NODE VAT0* (1st SEND: the destination)
SEND
  -DATA=HELLO, HOW ARE YOU ALL? (Subsequent SENDs: message to broadcast)
PREPARE_TO_RECEIVE
RECEIVE (Get DFS058 BROADCAST COMMAND COMPLETED)
RC=DEALLOCATE

```

## **Qualifying network LU names and commands**

Qualifying LU names gives the system administrator the liberty of using the same name for LUs on different systems by adding the network identifier. This eliminates the necessity to have unique names for every LU on every system in your complex.

A network-qualified LU name consists of a network identifier of the originating system that is 1 to 8 characters long, a period, and then the LU name, which is 1 to 8 characters long. IMS commands that include network-qualified LU names must be enclosed in single quotes. For example: 'NETID001.LUAPPC02'. No blanks are allowed in a network-qualified LU name.

The parameter ALL for either the network identifier or the LU name cannot be substituted in a command for a network-qualified LU name. ALL cannot represent all of the LU names or all of the networks.

The LU name in the LU 6.2 descriptors can be network-qualified.

The network-qualified LU name is optional on commands that support the LUNAME keyword.

## **Issuing commands to the OM API**

You can issue commands to the OM API and receive responses from the API by using a single point of control (SPOC) application such as the TSO SPOC, which is shipped with IMS.

### **Related concepts**

[CSL OM automated operator program clients \(System Programming APIs\)](#)

### **TSO SPOC format**

The TSO SPOC is an IBM-supplied application that can issue operator commands in an IMSplex.

The TSO SPOC application uses an ISPF panel interface and communicates with an Operations Manager (OM) address space. OM then communicates with all of the other address spaces in the IMSplex (for example, IMS) as required for operations. TSO SPOC can issue all type-2 commands and it has a set of panels dedicated to the task of managing resources (also known as issuing DRD-related commands).

There can be more than one TSO SPOC in an IMSplex. However, the TSO SPOC is optional in an IMSplex.

The TSO SPOC provides the following functions to an IMSplex:

- Presents a single system image for an IMSplex by allowing the user to issue commands to all IMS systems in the IMSplex from a single console.
- Displays consolidated command responses from multiple IMS address spaces.
- Sends a message to an IMS terminal connected to any IMS control region in the IMSplex by using the IMS **/BROADCAST** command.

There are several ways to issue commands in the IMS TSO SPOC application:

- By command line
- By retrieving a command
  - Using the ISPF RETRIEVE command
  - Using a command listed in the response area
  - Using the Command status panel
- By defining and using command shortcuts

You can use these methods in any combination at any time.

The following figure shows the format of the TSO SPOC screen.

```
File      Display      View      Options      Help
-----
PLEX1                                IMS Single Point of Control
Command ==> _____
-----
Response for:
----- Plex . _____ Route . _____ Wait . _____
CSLM000I (C) Copyright IBM Corp. 2000. All rights reserved.
F1=Help   f3=Exit   F4=Showlog F6=Expand   F9=Retrieve   F12=Cancel
```

*Figure 3. TSO SPOC screen format*

You can issue both IMS type-1 commands and type-2 commands using the TSO SPOC interface. Enter the command next to the command prompt (Command ==> in the figure above). Enter the IMSplex name in the Plex field. Enter the list of IMS systems to which to route the command, if applicable, in the Route field. After you type the command, press Enter. The command issued is shown in the Response for: field and the actual command response is shown below the Response for: field.

### **Entering comments from a TSO SPOC**

For type-1 IMS commands, a period ends a command and anything after it is a comment. The following example shows a type-1 IMS command with a comment.

```
/DISPLAY ACT .a test comment
```

For type-2 commands, the comment must be enclosed in a slash and asterisk. At the end of the last parameter of the command, type a forward slash followed by an asterisk, then the comment text, followed by an asterisk and slash. The comment text must not have an embedded asterisk slash in it. The following is an example of a command with a comment:

```
QUERY TRAN NAME(PART) SHOW(QCNT) /*Show queue count for tran part*/
```

## Batch SPOC format

The Batch SPOC is a utility program that uses OM services to submit IMS operator commands to an IMSplex. The utility program is not specific to DRD commands; it accepts any commands that are supported by the OM API.

The Batch SPOC utility is invoked by use of standard JCL statements. The following example shows a simple invocation:

```
//SPOCJOB JOB ,
// MSGCLASS=H,NOTIFY=&SYSUID,USER=&SYSUID/*
//SPOC EXEC PGM=CSLUSPOC,
// PARM=(' IMSPLEX=PLEX1,ROUTE=IMS3,WAIT=30,F=WRAP' )
//STEPLIB DD DISP=SHR,DSN=IMS.SDFSRESL
//SYSPRINT DD SYSOUT=*
//SYSIN DD *
QRY IMSPLEX SHOW(JOB,TYPE, +
STATUS)

QRY TRAN NAME(INV1*) SHOW(ALL) /* inventory appl */
/*EOF
```

The program parameters define the IMSplex environment. The parameter keywords are:

### IMSPLEX

Required parameter that specifies the 1- to 5-character suffix of the IMSplex name.

### F

Optional parameter that specifies the print format of the SPOC output. You can specify one of the following values:

#### WRAP

Wraps to the next line as needed. This is the default.

#### BYCOL

Lines of data are grouped together by the column.

#### BYRSC

Lines of data are grouped together by the resource.

### ROUTE

Optional parameter that specifies the SYSIDs of IMSplex members that are to execute the command. If ROUTE is not specified, all members of the IMSplex will execute the command. If more than one member is specified, enclose the list in parenthesis and separate the names with commas. For example:

```
// PARM=(' IMSPLEX=PLEX1,WAIT=30,ROUTE=(IMSZ,IMSA) ' )
```

If ROUTE=\* is specified, the command is routed to all registered command processing clients in the IMSplex. If ROUTE=% is specified, the command is routed to only one command processing client in the IMSplex that is registered for the command and that has MASTER capability. The Operations Manager chooses the command processing client.

### WAIT

Optional parameter that specifies the wait time for individual commands. The wait value is in minutes and seconds (MMM:SS) or just seconds (SSSSS). OM will return a single response as soon as a response is received from all of the members of the IMSplex. If the interval expires, OM will return any responses from IMSplex members, plus an indication that some did not reply. The Batch SPOC utility will wait for each command to complete before issuing the next command. The default wait value is five minutes (5:00). The WAIT time applies to every command in the SYSIN file. The user can specify a wait time of zero seconds; in this case, the batch SPOC issues a command but does not wait for the response.

The SYSIN file is provided by the user and contains the commands that the user wants to run. The commands are run serially. When one command completes, the next command is run until all records from the SYSIN file are processed. Continuation of the SYSIN control statements is specified by a plus sign (+) or a minus sign (-) as the last non-blank character of the line. A plus sign removes the leading

spaces from the next line; a minus sign keeps leading spaces. Comments can be included within the SYSIN file and are specified as:

```
/* this is a comment */
```

If the SYSIN is from a dataset, the DCB attributes must be set to LRECL=80 and BLKSIZE=80.

The SYSPRINT file will have the formatted command response. If more than one command is issued, the responses will appear in the same order as the commands appear in the SYSIN file. The default record length is 133. The command response is formatted in a similar format as the TSO SPOC display. If the records are too long, they wrap to the next line. The user may specify DCB information in the JCL or in the data set allocation to allow longer records in the SYSPRINT file.

System Display and Search Facility (SDSF) can be used to view batch job output. The following is an example of batch job output:

```
=====
Log for. . . : QRY IMSPLEX SHOW(MEMBER,TYPE,STATUS)
IMSpIex . . . : PLEX1
Routing . . . :
Start time. . . : 2005.132 15:36:28.11
Stop time . . . : 2005.132 15:36:29.17
Return code . . . : 00000000
Reason code . . . : 00000000
Command master. . : SYS3
IMSpIex MbrName   CC Member   Type   Status
CSLPLEX1 OM1      0 SYS3    DBDC  ACTIVE
CSLPLEX1 OM1      0 IMS2    DBDC  ACTIVE
=====
```

If no wait time, WAIT=0, is specified, the command response is not available and therefore are not printed. The SYSPRINT file will only have short summary information for each command. The following is an example of bath job output with no response:

```
=====
Log for. . . : QRY IMSPLEX SHOW(MEMBER,TYPE,STATUS)
IMSpIex . . . : PLEX1
Routing . . . :
Start time. . . : 2006.075 15:36:28.11
=====
```

### Related reference

[Issuing Batch SPOC commands \(Operations and Automation\)](#)

[Batch SPOC utility \(CSLUSPOC\) \(System Utilities\)](#)

## Command responses

With the exception of the **/DISPLAY** command, **/FORMAT** command, and type-2 commands returned through the OM API, responses to IMS commands are prefixed by the letters **DFSnnn**; *nnn* identifies the message.

A response to an IMS command is an acknowledgment from IMS to the originating terminal that the command has been received. Responses that go to the system console have an IMS ID that identifies the IMS system that issued the message. For example, the response to **/DBDUMP DATABASE MSDB** would be:

```
DFS058I (time stamp) DBDUMP COMMAND IN PROGRESS (IMS id)
```

At system definition, the **TIMESTAMP/NOTIMESTP** parameter of the **COMM** macro determines whether the time stamp is present or absent. If the time stamp feature is included, the date and time of the response appear between the response prefix and the text.

The **DFS058 COMMAND COMPLETED/IN PROGRESS** response indicates whether IMS accepted the command. If some parameters of the command are not accepted, the response includes the **EXCEPT** phrase and indicates the parameters that were not accepted. If IMS does not have the space for all of the not-accepted parameters, it truncates the **EXCEPT** phrase and terminates it with **...etc..** Commands that

specify the ALL parameter are most likely to be truncated. Truncated EXCEPT phrases on commands are normally caused by:

- Misspelling a parameter
- Specifying an invalid parameter for the command
- Specifying the ALL parameter for resources when some of them are already in the requested state

#### **Related reference**

[XML tags returned as CSL OM responses \(System Programming APIs\)](#)

## **Command responses to OM**

When an IMS type-2 command or IMS type-1 command is issued from the Operations Manager (OM) API, OM routes it (through the Structured Call Interface (SCI)) to one or more IMS systems based on the command routing. Each IMS returns the command response to OM. The command responses from each IMS are grouped together by OM and returned to the caller.

For each IMS command that is issued from OM API, the response is encapsulated in XML tags.

The type-2 command responses to OM also include a return code, reason code, and a possible completion code. The return or reason code returned for the command might also indicate an error from a Common Service Layer (CSL) request.

When the following type-1 commands are issued from OM API, the DFS058I COMMAND IN PROGRESS message is not returned. Instead, the messages that result as a part of command processing are returned to OM. Following is the list of commands that do not return the DFS058I COMMAND IN PROGRESS message:

- **/DBDUMP DB**
- **/DBRECOVERY AREA**
- **/DBRECOVERY DB**
- **/DBRECOVERY DATAGRP**
- **/LOCK DB**
- **/START AREA**
- **/START DB**
- **/START DATAGRP**
- **/STOP ADS**
- **/STOP AREA**
- **/STOP DB**
- **/STOP DATAGRP**
- **/UNLOCK DB**
- **/VUNLOAD AREA**

#### **Related concepts**

[How to interpret CSL request return and reason codes \(System Programming APIs\)](#)

#### **Related reference**

[Return and reason codes for commands to OM \(Messages and Codes\)](#)

## **Responses to LU 6.2 devices**

The response to a command from an LU 6.2 device is sent synchronously if the initiating conversation is not deallocated by the remote device. If the conversation is deallocated, the command response is sent asynchronously using the LUNAME of the device and a TPN of DFSCMD. The remote device must allocate separate DFSCMD conversations to receive each asynchronous message.

When the following commands are entered from LU 6.2 devices:



- /DBDUMP DATABASE
- /DBRECOVERY AREA
- /DBRECOVERY DATABASE
- /START AREA
- /START DATABASE
- /START REGION
- /STOP AREA
- /STOP DATABASE
- /STOP REGION

The DFS058 COMMAND COMPLETED message is generated instead of the DFS058 COMMAND IN PROGRESS message. If the LU 6.2 conversation is synchronous (the conversation still exists), the DFS058 COMMAND COMPLETED message is the last message the operator receives. If the LU 6.2 conversation is asynchronous (the conversation is deallocated), the order of delivery of the DFS058 message can vary.

## Sending messages to the z/OS system console

---

Each z/OS system console in the sysplex has a unique LTERM name.

In an XRF environment, the real z/OS system console name is the RSE name specified in the HSB member. For a non-XRF subsystem, the real system console name is the IMS ID. The generic z/OS system console name is always "WTOR". The generic name is translated to the real LTERM name when a message is sent to the z/OS system console.

Because each z/OS system console has a unique LTERM name, a message can be sent to any z/OS system console in the sysplex if the real LTERM name (not the generic name) is used.

## Sending messages to the IMS master terminal

---

Each IMS master terminal (MTO) in the sysplex has a unique LTERM name, and if they are VTAM terminals they also have unique node names.

Each IMS assigns its primary MTO the default LTERM name "DFSPMTO" as a generic name. Each secondary MTO is assigned "DFSSMTO" as the default generic name. You can override either of these default generic names during IMS system definition by using the DFSDCxxx member of IMS.PROCLIB. The generic name is translated to the real LTERM name when a message is sent to the MTO.

**Restriction:** If you use the DFSDCxxx member to override a default generic name, you must not specify a statically-defined node name. Also, the node name you specify must have the same physical characteristics as the default node you are overriding. If you change the DFSDCxxx member, you must perform a cold start of IMS.

In a shared-queues environment, because each MTO has a unique LTERM name, a message can be sent to any MTO in the sysplex if you use the real LTERM name (not the generic name).

### Related reference

[DFSDCxxx member of the IMS PROCLIB data set \(System Definition\)](#)

## IMS terminal command examples

---

Some command examples show the format of commands entered and received from an IMS terminal--entry terminal (ET), master terminal (MT), or response terminal (RT). One or more examples are given for each command.

The examples show:

Entry ET:

How the command looks as entered from the entering terminal (ET).

Response ET:

The IMS response transmitted to the entering terminal (ET).

Entry MT:

How the command looks as entered from the master terminal (MT).

Many IMS commands reference other terminals. Examples of these commands include:

Response RT:

The IMS response transmitted to the referenced terminal or terminals (RT).

The ET and RT responses might or might not print or display, depending on what type of terminal is referenced and whether the MSGDEL (message delete) option was specified for the terminal at system definition time.

## TSO SPOC command examples

Both type-2 commands and type-1 commands can be entered from a TSO SPOC. **/START DB** command, which is a type-1 command, and **CREATE DB** command, a type-2 command, are used as examples to show the input and output from a TSO SPOC.

### Type-1 command example

The input and output of **/START DB** command from a TSO SPOC is shown as follows:

TSO SPOC input:

```
STA DB BANKATMS BANKTERM BANKLDGR BE3ORDER
```

TSO SPOC output:

```
SYS3 DFS0488I STA COMMAND COMPLETED. DBN= BANKATMS RC=04
SYS3 DFS0488I STA COMMAND COMPLETED. DBN= BANKTERM RC=04
SYS3 DFS0488I STA COMMAND COMPLETED. DBN= BANKLDGR RC=04
SYS3 DFS0488I STA COMMAND COMPLETED. DBN= BE3ORDER RC=08
IMS3 DFS0488I STA COMMAND COMPLETED. DBN= BANKATMS RC=04
IMS3 DFS0488I STA COMMAND COMPLETED. DBN= BANKTERM RC=04
IMS3 DFS0488I STA COMMAND COMPLETED. DBN= BANKLDGR RC=04
IMS3 DFS0488I STA COMMAND COMPLETED. DBN= BE3ORDER RC=08
```

### Type-2 command example

The input and output of **CREATE DB** command from a TSO SPOC is shown as follows:

TSO SPOC input:

```
CREATE DB NAME(DB000001,DB000002,DB000003) SET(ACCTYPE(UPD),RESIDENT(Y))
```

TSO SPOC output:

| DBName   | MbrName | CC |
|----------|---------|----|
| DB000001 | IMS1    | 0  |
| DB000002 | IMS1    | 0  |
| DB000003 | IMS1    | 0  |

## OM API command examples

---

Some command examples show the input and output of commands to and from the OM API. Both type-2 commands and type-1 commands can be entered from the OM API. One or more examples are given for each command.

The examples show:

OM API input:

```
How the string looks as built by the AOP client.
```

OM API output:

```
The response with XML tags sent from OM.
```

Explanation: An explanation of the command and response.

Some type-2 commands include a section describing the environment of the IMSplex prior to entering the command.

## IMS type-1 command format

---

This section describes the general format for an IMS type-1 command.

Subsections:

- [“Command recognition character” on page 15](#)
- [“Verb” on page 15](#)
- [“Keywords” on page 15](#)
- [“Parameters” on page 16](#)
- [“Null keywords” on page 19](#)
- [“Comments” on page 19](#)
- [“Passwords” on page 19](#)

### Command recognition character

The slash (/) is the command recognition character for IMS commands. In a DBCTL environment, another character can be defined as the command recognition character and would replace the slash.

### Verb

The /VERB (such as /**STOP**) is the first command element and identifies the action to be taken. To abbreviate a verb, use only the slash and the first three characters. Enter the characters using either uppercase or lowercase letters.

### Keywords

IMS keywords are reserved words identifying IMS resources that relate to transaction management, databases, or the IMS system. Many commands require one or more keywords.

[Table 79 on page 59](#) is a list of available keywords and their synonyms. The alphabetic list of keywords after [Table 79 on page 59](#) explains the use of the keyword for each IMS command it affects.

**Restriction:** Keywords and their synonyms are reserved words. Do not use reserved words to name system resources such as transactions, programs, logical terminals, databases, and MFS block names.

Keywords are shown in uppercase. The keyword or an allowable synonym can be entered in uppercase or lowercase.

## Parameters

Parameters refer to installation defined or created resources, such as nodes, databases, or physical terminals, or IMS reserved parameters. Parameters in IMS commands must be replaced with parameter values. Reserved parameters have a unique meaning to IMS and refer to system resources or functions.

The format of the parameters that can be entered is determined by the command and keyword with which they are associated. Use the syntax example provided at the beginning of each command description to determine the valid parameter formats for that command.

When commands are entered, parameters are separated from a keyword by a space or an equal sign (=). Multiple parameters are separated by a comma, a blank, or a comma followed by a blank. The last parameter of one keyword is separated from the next keyword either by a space, a comma, or an equal sign.

In the syntax examples, default parameters appear above the syntax line. Optional parameters appear below the syntax line.

In the syntax examples, a repeat-line is shown as follows:

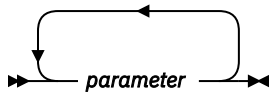

The repeat-line indicates that multiple parameters can be entered. To save time while entering multiple parameters for the LINE, PTERM, NODE, and LINK keywords, inclusive parameters can be specified in some commands.

**Restriction:** Use of the ALL parameter, generic parameters, or excessive use of multiple or inclusive parameters in the large terminal network can cause some of the following problems:

- "Lock out" of the operator for the duration of the command processing
- Creation of large multisegment output messages
- Command action for only part of the terminal resources intended
- Temporary storage shortages
- Artificially high storage pools within IMS, VTAM, or both

### **Reserved words**

The resources you define, such as nodes, physical terminals, and databases, may be referenced as parameter values in IMS commands. Do not use reserved words to name these resources, or IMS might not interpret the command as expected. For example, if you define a node called TKOTRA and issue a **/DISPLAY NODE TKOTRA** command, IMS will list all the nodes that have an attribute of TKOTRA, instead of the specific node named TKOTRA.

### **ALL parameter**

Entering the reserved parameter ALL specifies all defined resources related to that keyword. ALL cannot be used with every command.

ALL=NO or ALL=DIS can be specified on the KEYWD macro to prevent use of the ALL parameter. ALL=NO and ALL=DIS can be specified for all keywords. ALL=NO indicates that the ALL parameter is invalid on all the commands for the keyword. ALL=DIS indicates that the ALL parameter is invalid on all the **/DISPLAY** commands for the keyword.

### **Inclusive parameters**

Inclusive parameters are used to specify a group of parameters by entering only the first and last parameters of the group. Inclusive parameters can be used for the following resources:

- Line
- Link
- Static node
- PTERM

To use inclusive parameters, enter the first parameter, a hyphen, then the last parameter (parameter1-parameter2).

For the LINE, PTERM, and LINK keywords, the group of parameters specified is assumed to be based on numeric sequence; that is, entering 3-6 specifies parameters 3, 4, 5, and 6. Inclusive parameters are limited to the PTERM keyword when it appears with the LINE keyword in a command. For the NODE keyword, the group of parameters must be static and based on the IMS definition sequence, not numeric or alphabetic sequence.

### **Generic parameters**

You can use generic parameters to specify a group of resources whose names match a 1- to 8-character alphanumeric mask. Generic parameters apply to both type-1 and type-2 commands.

A generic parameter can include one or more of the following wildcard characters:

**\***

Matches zero or more characters. When used alone, it matches all the names for the keyword or resource.

**%**

Matches exactly one character.

The following examples illustrate some uses of wildcard characters:

**C0\***

Matches any string of any length that begins with C0. For instance: C0, C00, C00P

**%%S**

Matches any 3-character string that ends with S. For instance: IMS, XYS

**C0\*%%1**

Matches any string of 5 or more characters that starts with C0, ends with 1, and has at least 2 characters between C0 and 1. For instance: CONV1, CONV21, CONV221, CONV23B1

Specifying an asterisk alone as the generic parameter (such as NAME(\*)) is equivalent to specifying ALL (such as NAME(ALL)). However, depending on the installation, other generic parameters can mean ALL. For example, the generic parameter %%%% means ALL to an installation whose resource names are all 4 characters long. Some commands support NAME(\*) and do not support NAME(ALL) for a wildcard name.

When a generic parameter is used, IMS uses a serial search of all resources to match the generic name. Using a serial search of all resources can have performance implications in larger systems.

**Restriction:** For type-1 commands, if you specify ALL=NO on the KEYWD macro, you cannot use an asterisk (\*) or ALL for the keyword. However, if you specify ALL=NO on the KEYWD macro, you can use other generic parameters that are equivalent to ALL. If you are using BASIC EDIT, and you enter a command with a generic parameter containing two asterisks in a row at the end of the command, the command is discarded.

The following table lists some of the type-1 commands and keywords that support generic parameters.

Table 1. Type-1 commands and keywords that support generic parameters

| Command       | Keyword supported               |
|---------------|---------------------------------|
| /BROADCAST    | LTERM, NODE, USER               |
| /CHANGE       | NODE                            |
| /CLSDST       | NODE                            |
| /DISPLAY      | LTERM, MSNAME, NODE, TRAN, USER |
| /DISPLAY ASMT | LTERM, MSNAME, NODE, USER       |
| /DISPLAY CONV | NODE, USER                      |
| /IDLE         | NODE                            |
| /OPNDST       | NODE                            |
| /PSTOP        | LTERM, TRAN                     |
| /PURGE        | LTERM, MSNAME, TRAN             |
| /RSTART       | NODE, USER                      |
| /START        | LTERM, MSNAME, NODE, TRAN, USER |
| /STOP         | LTERM, MSNAME, NODE, TRAN, USER |
| /TRACE        | NODE                            |

**Restriction:** Generic parameters are not supported in NODE, USER, or TRAN CLASS combinations.

### Group parameters

A group parameter allows easy specification of a group of resources, where the resources in the group are defined and managed by the installation. Group parameters apply to both type-1 and type-2 command.

Group parameters are supported with the DATAGR<sub>P</sub> keyword for the **/DBRECOVERY**, **/START**, **/STOP**, and **UPDATE** (type-2) commands. A group name is one to eight characters long. It is associated with a list of databases, DEDB areas, or database data sets.

A database group name and its associated databases or DEDB areas is defined in the DBRC RECON data set using the DBRC **INIT.DBDSGRP** command with parameters GRPNAME and DBGRP.

A database data set (DBDS) group name and its associated DBDSs is defined in the DBRC RECON data set using the DBRC **INIT.DBDSGRP** command with parameters GRPNAME and MEMBERS.

- Adding resources to a group

Use the **CHANGE.DBDSGRP** command with the GRPNAME and ADDDB parameters to add databases or areas to a database group.

Use the **CHANGE.DBDSGRP** command with the GRPNAME and ADDMEM parameters to add DBDSs to a DBDS group.

- Deleting resources from a group

Use the **CHANGE.DBDSGRP** command with the GRPNAME and DELDB parameters to delete databases or areas from a database group.

Use the **CHANGE.DBDSGRP** command with the GRPNAME and DELMEM parameters to delete DBDSs from a DBDS group.

- Displaying resources in a group

Use the **LIST.DBDSGRP** command or the online **/RMLIST** command to display the databases or areas in a database group, or the DBDSs in a DBDS group.

Groups defined for commands should contain only databases and areas for use with the DATAGROUP keyword.

## Null keywords

Null keywords are used to help clarify the syntax of the command being entered but have no effect on the command. Null keywords can be used within IMS commands at any time. However, they cannot be used with type-2 commands. Null keywords are reserved words. Do not use them to name system resources. The following are IMS null keywords:

- AFTER
- FOR
- ON
- SECURITY
- TO

## Comments

You can add comments or notes to the end of a command. When you add comments, identify the end of the command by entering a period after the last parameter. If you do not enter a period, residual data from a 3270 affects command processing.

## Passwords

Depending on the password security arrangement of the defined IMS system and the terminal where the command is entered, a password can be required after the command verb, or after a parameter or a keyword of certain commands.

If a command password is required, it must be entered immediately after **/VERB** and is normally enclosed in parentheses. No spaces or intervening characters are allowed between the **/VERB** and the left parenthesis.

When using MFS, if a command password is required, the installation-defined MFS format must contain a defined password field. The password must be entered into the password field defined by the format displayed. If command entry field of the format is defined to accept the command verb only, message DFS1051 is issued when an attempt is made to enter **/VERB(password)**.

None of the IMS-supplied default formats (exception for the master terminal format) have a password field defined.

You must use RACF or an equivalent security product to require a command verb password associated with the user ID signed on to the dynamic terminal.

The **/LOCK** and **/UNLOCK** command keywords and parameters support passwords.

The **/LOCK** and **/UNLOCK** command parameters also support passwords when defined for users using RACF for static and dynamic resources. The password associated with a signed on user and specified after a command resource parameter will be used to perform a reverification check, if the resource is defined to RACF with 'REVERIFY' specified in the APPLDATA field. If the resource passes the RACF authorization check, and RVFY=Y is specified as an IMS startup parameter, IMS will verify that the password following the parameter is the same as the password entered during signon for the user that entered the command. If 'REVERIFY' is specified for a resource, but a password is not provided, or the wrong password is provided, the command processing for that resource will be rejected. This is also true for the **/SET TRANSACTION** and **/SET CONVERSATION** commands.

The use of passwords is not shown in the examples.

## Related reference

[“List of reserved words” on page 93](#)

Some words are used and reserved only for IMS commands.

IMS Command Language Modification facility (DFSKWD0) (Exit Routines)

## IMS type-2 command format

IMS type-2 commands use a different format from the format used by IMS type-1 commands.

Type-2 commands can be issued only through the Operations Manager (OM) APIs by an automated operator program (AOP). An example of an AOP is the IBM-supplied TSO single point of control (SPOC) application. These commands cannot be entered from the system console, the MTO, an end-user terminal, or an IMS AOI application program. Type-2 commands are not passed to the IMS AOI user exits and are also not logged to the IMS secondary master.

Almost all commands issued through the OM API (including the IMS type-1 commands) do not require a command recognition character (for example, a slash). If one is supplied, the OM API will ignore it. The only exception to this rule is the type-1 **/EXIT** command, which requires a slash when entered from a TSO SPOC application.

The command format with common keywords is as follows:

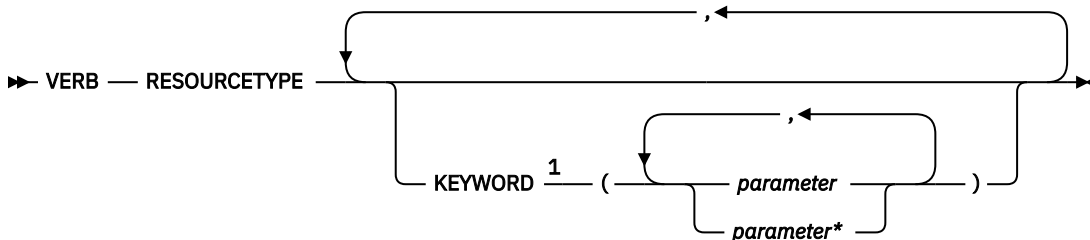

Notes:

<sup>1</sup> For some commands, KEYWORD is required, not optional.

The following is a list of the parameters with a short description of each.

### VERB

Identifies the action to be taken. The command verb can be abbreviated.

### RESOURCETYPE

Identifies the type of resource the command acts upon. The following is a list of the resource types:

#### AREA

An area resource in an IMS.

#### DATAGRP

The members of a data group in an IMS.

#### DB

The database in an IMSplex.

#### DBDESC

The databases descriptor in an IMSplex.

#### IMSCON

IMS Connect resources.

#### IMS

Status and attributes of an IMS.

#### IMSPLEX

A group of IMS systems, CSL (SCI, OM, RM) members and CQs.

#### LE

Language Environment® runtime parameter definitions.

#### MEMBER

An IMSplex component (For example, an IMS, OM, RM, or SCI).



**MSLINK**

Logical links.

**MSPLINK**

Physical links.

**MSNAME**

Logical link paths.

**ODBM**

Open Database Manager (ODBM), a component of the Common Service Layer (CSL).

**OLC**

An online change process.

**OLREORG**

An online reorganization of a HALDB partition.

**OTMADESC**

IMS Open Transaction Manager Access (OTMA) destination descriptor.

**PGM**

A program in an IMS.

**PGMDESC**

A program descriptor in an IMS.

**RM**

Resource Manager (RM) address space.

**RTC**

A Fast Path routing code.

**RTCDESC**

A Fast Path routing code descriptor.

**STRUCTURE**

A resource structure managed by RM.

**TRAN**

An IMS resource that is a message destination.

**TRANDESC**

An IMS descriptor that is a message destination.

**KEYWORD()**

Optional command elements, depending upon the specific command.

***parameter***

Identifies an IMS-defined value or an installation-defined or created resource. Most parameters can end with a wildcard (an asterisk - \*). Parameters are listed in parentheses and must be replaced with parameter values. Multiple parameters are separated by a comma.

When a keyword and a keyword parameter are specified in the format `KEYWORD(parameter)`, the parameter can include embedded blanks, commas, and parentheses. However, if parentheses are embedded in the parameter, the parentheses must be paired and properly nested. For example, `KEYWORD(ABC(DEF))` is valid, but `KEYWORD(ABC(DEF)` is invalid.

If an optional keyword is specified without any parameters listed within the parentheses, the keyword is assigned a null value and is treated as if the keyword was not specified at all.

**Generic parameters**

You can use generic parameters to specify a group of resources whose names match a 1- to 8-character alphanumeric mask. Generic parameters apply to both type-1 and type-2 commands.

A generic parameter can include one or more of the following wildcard characters:

**\***  
Matches zero or more characters. When used alone, it matches all the names for the keyword or resource.

**%**  
Matches exactly one character.

The following examples illustrate some uses of wildcard characters:

**C0\***  
Matches any string of any length that begins with C0. For instance: C0, C00, C00P

**%%S**  
Matches any 3-character string that ends with S. For instance: IMS, XYS

**C0\*%%1**  
Matches any string of 5 or more characters that starts with C0, ends with 1, and has at least 2 characters between C0 and 1. For instance: CONV1, CONV21, CONV221, CONV23B1

Specifying an asterisk alone as the generic parameter (such as NAME(\*)) is equivalent to specifying ALL (such as NAME(ALL)). However, depending on the installation, other generic parameters can mean ALL. For example, the generic parameter %%%% means ALL to an installation whose resource names are all 4 characters long. Some commands support NAME(\*) and do not support NAME(ALL) for a wildcard name.

When a generic parameter is used, IMS uses a serial search of all resources to match the generic name. Using a serial search of all resources can have performance implications in larger systems.

The following table lists some of the type-2 commands and keywords that support generic parameters.

*Table 2. Type-2 commands and keywords that support generic parameters*

| <b>Command</b> | <b>Keyword supported</b>   |
|----------------|--|
| DELETE         | NAME with DB, DBDESC, PGM, PGMDESC, RTC, RTCDESC, TRAN, or TRANDESC                                |
| EXPORT         | NAME with DB, DBDESC, PGM, PGMDESC, RTC, RTCDESC, TRAN, or TRANDESC                                |
| IMPORT         | NAME with DB, DBDESC, PGM, PGMDESC, RTC, RTCDESC, TRAN, or TRANDESC                                |
| QUERY          | NAME with AREA, DB, DBDESC, MSLINK, MSNAME, MSPLINK, PGM, PGMDESC, RTC, RTCDESC, TRAN, or TRANDESC |
| QUERY LE       | LTERM, TRAN, USERID, PROGRAM   |
| UPDATE         | NAME with AREA, DB, DBDESC, MSLINK, MSNAME, MSPLINK, PGM, PGMDESC, RTC, RTCDESC, TRAN, or TRANDESC |

**Restriction:** Generic parameters are not supported in a TRAN CLASS combination.

#### **Related concepts**

[Issuing type-2 IMS commands \(System Programming APIs\)](#)

[Type-2 command environment \(System Administration\)](#)

## **Sending commands to the IMSplex**

After setting up an IMSplex, you can issue commands using the TSO single point of control (SPOC) interface.

You can also write an automated operator program that can issue the same commands. The TSO SPOC provides integrated online help.

The IMS Application Menu provides a common interface to enable you to start applications such as TSO SPOC, Syntax Checker, IVP, and more.

**Important:** SPOC applications (including the TSO SPOC and the Batch SPOC utility) issue the CSLOMCMD request. You therefore need to be aware of the parameters and return and reason codes of the CSLOMCMD request.

If you write automated programs, those programs must include logic to handle the responses from the commands; the automated programs have to parse the XML statements.

Most commands that are issued to an IMSplex are issued to OM. The exceptions are:

- BPE commands, which can be issued directly to CSL members and to CQS.
- The **SHUTDOWN** command, which can be issued directly to SCI to shut down one or more CSL members.
- Query requests issued by a z/OS master console to the CSL.

In an IMSplex, the format, behavior, and responses to certain IMS commands have changed. Some IMS commands are no longer recoverable; others are not supported in an IMSplex. Some commands are supported only in an IMSplex.

### **Related concepts**

[Other sample applications verified by the IVP \(Installation\)](#)

[Controlling IMS with the TSO SPOC application \(Operations and Automation\)](#)

[IMS Application Menu \(System Administration\)](#)

### **Related reference**

[CSLLOMCMD: command request \(System Programming APIs\)](#)

## **Command processing in an IMSplex**

---

In an IMSplex environment, IMS commands issued through OM can behave differently than when those same commands are issued to an individual IMS subsystem.

Type-2 commands can be issued only through the OM API. Type-1 IMS commands can be issued through the OM API or to individual IMS systems through end-user terminals, master terminals, system consoles, or AOI applications. The following sections describe some of the behavioral differences.

### **Command routing**

Commands that are issued to OM are, by default, routed to all the IMSplex components that are active and have registered interest in processing those commands. If you want to route a command to one or more specific IMS systems in the IMSplex, use the ROUTE() parameter on the command request.

OM selects one IMSplex member (that is, IMS or RM) that is registered for the command to be the command master for each command from the OM API. The command master performs global command actions where applicable. An XRF alternate system is not a command master candidate until it takes over.

Type-2 command responses may differ depending on which IMSplex member was the command master. For example, for a QUERY TRAN NAME(*tranname*) QCNT (GT 1) SHOW(ALL) command, only the command master returns the global queue counts, unless it does not have access to the shared queues (for example, the command master is local queues enabled).

If a command is routed to multiple IMS systems and the command fails on some of those systems as a result of environmental reasons (such as /DBR to an XRF alternate system), the overall OM return code will not reflect the environmental error.

If a command fails on all systems to which it is routed because of environmental reasons, IRC\_LIST and IRSN\_LISTNONE are produced. For type-1 commands, any error messages that are associated with the invalid environment errors will also be sent back for display. For type-2 commands, the return and reason code returned by the IMS system are from OM.

### **Command behavior and the Resource Manager**

Depending on whether an IMSplex is defined with a Resource Manager (and there is a resource structure available to RM), command behavior can be affected. When a resource structure is not defined, resource status must be maintained on local IMS systems in the IMSplex. In this case, commands have only a local effect.

If RM is defined with a resource structure and STM is enabled in the IMSplex, RM maintains global resource information, including resource status, for nodes, LTERMS, and users. In this scenario, resource status is maintained both globally and locally. Usually, if a user signs off or a client shuts down, resources status is maintained globally but deleted locally. If you do not want TM resources to be updated in RM, you can specify STM=NO in the PROCLIB member, DFSDCxxx.

As an alternative to STM=NO, users can choose to disable resource sharing for static ISC resources only. If this option is set, the command status for static ISC resources is always considered local as if there were no resource structure. Commands processed for a static ISC node or subpool only modify local status. Status is not updated in the resource structure. The purpose of the option is to remove the unique name restriction for static ISC-related resources so that static ISC LTERM and subpool names can be active multiple times concurrently in an IMSplex.

Another behavior that is worth noting is how command processing clients process type-1 commands (related to nodes, LTERMS, and users) that are routed to the entire IMSplex. In general, OM chooses one of the command processing clients in the IMSplex to be the "master" to coordinate the processing of the type-1 commands. Whether the master (or a non-master) IMS will process a type-1 command depends on where the command resource status is kept. If the command resource status is kept in a resource structure, the type-1 command will usually be processed by a non-master client where the command resource is active. If the command resource is not active on any of the command processing clients in the IMSplex, OM will still route the type-1 command to all clients in the IMSplex, but only the master client will process the command. If the type-1 command is being routed to all the clients in the IMSplex, command processing clients where the command resource is not active will reject the type-1 command.

#### **Related reference**

[DFSDCxxx member of the IMS PROCLIB data set \(System Definition\)](#)  
[Initialization exit routine \(DFSINTX0\) \(Exit Routines\)](#)

## **Command characteristics**

---

Command characteristics and operations (the way commands actually work) are affected by terminal security defaults, command recoverability, and whether commands are logged to the secondary master terminal, supported from an AOI application, mirrored on the XRF alternate, supported from the XRF alternate, and supported from LU 6.2 devices.

## **Terminal security defaults for IMS type-1 commands**

---

When neither RACF (RACF=NONE) nor the command security exit (DFSCCMD0) is used, all type-1 commands are allowed from the master terminal, except those that apply to the terminals from which the commands are issued. Only some commands are allowed from a remote terminal in this case.

The following table shows the terminal security defaults for IMS commands from the master terminal and remote terminals when neither RACF (RACF=NONE) nor the command security exit (DFSCCMD0) is used. Only the commands shown in the table are allowed in these environments.

*Table 3. Terminal security defaults for IMS type-1 commands*

| <b>Master terminal</b> | <b>Remote terminal</b> |
|------------------------|------------------------|
| /ACTIVATE              |                        |
| /ALLOCATE              |                        |
| /ASSIGN                |                        |

Table 3. Terminal security defaults for IMS type-1 commands (continued)

| <b>Master terminal</b> | <b>Remote terminal</b> |
|------------------------|------------------------|
| /BROADCAST             | /BROADCAST             |
| /CANCEL                | /CANCEL                |
| /CHANGE                |                        |
| /CHECKPOINT            |                        |
| /CLSDST                |                        |
| /COMPT                 |                        |
| /CQCHKPT               |                        |
| /CQQUERY               |                        |
| /CQSET                 |                        |
| /DBDUMP                |                        |
| /DBRECOVERY            |                        |
| /DELETE                |                        |
| /DEQUEUE               |                        |
| /DIAGNOSE              | /DIAGNOSE              |
| /DISPLAY               |                        |
| /END                   | /END                   |
| /ERESTART              |                        |
| /EXCLUSIVE             | /EXCLUSIVE             |
| /EXIT                  | /EXIT                  |
| /FORMAT                | /FORMAT                |
| /HOLD                  | /HOLD                  |
| /IDLE                  |                        |
| /INITIATE              |                        |
| /LOCK                  | /LOCK                  |
| /LOG                   | /LOG                   |
| /LOOPTEST              | /LOOPTEST              |
| /MODIFY                |                        |
| /MONITOR               |                        |
| /MSASSIGN              |                        |
| /MSVERIFY              |                        |
| /NRESTART              |                        |
| /OPNDST                |                        |
| /PSTOP                 |                        |
| /PURGE                 |                        |

Table 3. Terminal security defaults for IMS type-1 commands (continued)

| Master terminal | Remote terminal |
|-----------------|-----------------|
| /QUIESCE        |                 |
| /RCLSDST        | /RCLSDST        |
|                 | /RCOMPT         |
| /RDISPLAY       | /RDISPLAY       |
| /RECOVER        |                 |
| /RELEASE        | /RELEASE        |
| /RESET          | /RESET          |
| /RMxxxxxx       | /RMLIST         |
| /RSTART         |                 |
| /RTAKEOVER      |                 |
| /SECURE         |                 |
| /SET            | /SET            |
| /SIGN           | /SIGN           |
| /SMCOPY         |                 |
| /SSR            |                 |
| /START          |                 |
| /STOP           |                 |
| /SWITCH         |                 |
| /TERMINATE      |                 |
| /TEST           | /TEST           |
| /TRACE          |                 |
| /UNLOCK         | /UNLOCK         |
| /UPDATE         |                 |
| /VUNLOAD        |                 |

## Commands recovered during emergency restart

Certain commands that successfully alter IMS resources are written to the system log as X'02' or X'22' log records and are reprocessed during emergency restart.

IMS type-1 commands that are recovered during emergency restart write an X'02' log record. Type-2 commands that are recovered during emergency restart write an X'22' log record. The following table lists the commands, along with the exceptions, that are recovered during emergency restart.

Table 4. Commands recovered during emergency restart

| Command | Exceptions         |
|---------|--------------------|
| /ASSIGN |                    |
| /CHANGE | /CHANGE DESCRIPTOR |

Table 4. Commands recovered during emergency restart (continued)

| Command        | Exceptions   |
|----------------|--|
| CREATE         |  |
| /DELETE        |  |
| DELETE         |  |
| /END           |  |
| /EXCLUSIVE     |  |
| /EXIT          |  |
| /HOLD          |  |
| /LOCK          | /LOCK LTERM, /LOCK NODE, /LOCK PTERM                       |
| /LOG           |  |
| /MONITOR       |  |
| /MSASSIGN      |  |
| /PSTOP         | /PSTOP LTERM   |
| /PURGE         | /PURGE APPC, /PURGE LTERM                                  |
| /RELEASE       |  |
| /RSTART        |  |
| /SET           | /SET LTERM, /SET TRAN                                      |
| /SMCOPY        |  |
| /START         | /START APPC, /START ISOLOG, /START TRKARCH, /START PROG    |
| /STOP          | /STOP APPC   |
| /TEST MFS      | /TEST LINE, /TEST NODE, /TEST USER                         |
| /UNLOCK        | /UNLOCK LTERM, /UNLOCK NODE, /UNLOCK PTERM, /UNLOCK SYSTEM |
| UPDATE DB      |  |
| UPDATE MSLINK  |  |
| UPDATE MSNAME  |  |
| UPDATE MSPLINK |  |
| UPDATE PGM     |  |
| UPDATE RTC     |  |
| UPDATE TRAN    | UPDATE TRAN START(TRACE), UPDATE TRAN STOP(TRACE)          |

**Restriction:** If an IMS outage (abend, modify, or cancel of IMS) occurs immediately after a command is entered, the command status might not be carried across an emergency restart or XRF takeover.

The command log records are logged asynchronously (no check write or wait write). If there is no other IMS activity that forces the log buffer to be written to the OLDS or WADS data set, the status set by the command, for restart purposes, did not occur.

There are many events in IMS where log records are check-written to the log. Any one of these events subsequent to the command causes the command log record to be written to the OLDS or WADS data set.

## Command processing in a dynamic resource definition environment

---

IMS processes commands differently in a dynamic resource definition (DRD) environment than in a non-DRD environment.

If you are running without DRD enabled, the control blocks that manage the resources (DDIRs, PDIRs, SMBs, and RCTEs) are loaded from the MODBLKS data set at cold start. If a type-1 command is issued to change the attribute of a resource (such as the database access type or the transaction class), the internal control blocks are updated and the changes are recovered across a warm or emergency restart. If you perform a cold start, however, the control blocks are reloaded from the MODBLKS data set, so the updated attributes revert to the original values unless you have updated your MODBLKS data set.

If you are running with DRD enabled, any changes that you make to resource definitions by using type-1 or type-2 commands persist across a warm or emergency restart. These changes also persist across a cold start if the updated resource definitions are exported to either a resource definition data set (RDDS) or the IMSRSC repository, and then imported from the RDDS or the repository during cold start. When you export the resource definitions to an RDDS or the repository, all the current attribute values are exported. If you change the value of one of the attributes by using a type-1 or type-2 command (such as the database access type or the transaction class), the updated attribute is exported. You can either use the type-2 **EXPORT DEFN** command to export resource definitions explicitly, or use the automatic export function to have IMS export the definitions automatically during IMS normal checkpoints. The updated attribute values are then imported during cold start if automatic import is enabled.

### Related concepts

[Considerations for using dynamic resource definition \(System Definition\)](#)

## IMS type-1 commands logged to the secondary master terminal

---

The secondary master terminal provides a hardcopy log of system activity, including checkpoint information and error messages.

If the hardcopy logging facility has been selected and not disabled (using the **/SMCOPY** command), certain IMS commands and responses are logged on the secondary master terminal.

You can select whether only commands issued from the master terminal are logged, only commands entered from other terminals are logged, or both are logged. Only the commands listed in the following table are logged to the secondary master terminal.

---

*Table 5. IMS type-1 commands logged to the secondary master terminal*

---

| Commands    | Commands (continued) |
|-------------|----------------------|
| /ACTIVATE   | /QUIESCE             |
| /ALLOCATE   | /RCLSDST             |
| /ASSIGN     | /RCOMPT              |
| /CHECKPOINT | /RECOVER             |
| /CLSDST     | /RMCHANGE            |
| /COMPT      | /RMDELETE            |
| /CQCHKPT    | /RMGENJCL            |
| /CQQUERY    | /RMINIT              |
| /CQSET      | /RMLIST              |
| /DBDUMP     | /RMNOTIFY            |
| /DBRECOVERY | /RSTART              |

---



Table 5. IMS type-1 commands logged to the secondary master terminal (continued)

| Commands          | Commands (continued) |
|-------------------|----------------------|
| /DELETE           | /RTAKEOVER           |
| /DEQUEUE          | /SECURE              |
| /DIAGNOSE         | /START               |
| /DISPLAY          | /STOP                |
| /IDLE             | /SWITCH              |
| /INITIATE OLREORG | /TERMINATE OLREORG   |
| /MODIFY           | /TRACE               |
| /MONITOR          | /UPDATE MSLINK       |
| /MSASSIGN         | /UPDATE OLREORG      |
| /OPNDST           | /UNLOCK SYSTEM       |
| /PSTOP            | /VUNLOAD             |
| /PURGE            |                      |

## IMS type-1 commands supported from an AO application

Automated operator (AO) applications are application programs that issue IMS operator commands using DL/I calls.

AO applications can use two different DL/I calls to issue commands: CMD and ICMD. This section lists which IMS commands can be issued using each of these calls and describes command security for AO applications.

AO applications using the CMD and ICMD call can use RACF, DFSCCMD0, or both for security.

The TSO SPOC and REXX SPOC API are IMS applications that use OM API and cannot issue commands through DL/I calls.

### Issuing IMS type-1 commands by using the CMD call

If you are using the CMD call to issue IMS commands, transactions can be defined as AO applications with AOI= on the TRANSACT system definition macro. AO transactions are invoked in the same way any IMS transaction is invoked. AO transactions run as IMS applications with the authority to issue a planned series of IMS commands. For example, an AO application can be called in by an AO transaction after a normal restart of IMS to start IMS resources. The AO application would consist of those commands regularly used by the master terminal operator (MTO) after IMS is active. Fast Path exclusive transactions cannot be defined as AO transactions.

When RACF (or an equivalent product) is used for type-1 AOI security, the AOI= parameter on the TRANSACT macro defines which transactions can issue commands. RACF (or an equivalent product) defines which commands are allowed for each authorized transaction. These definitions in RACF give control to the authorized user who entered the transaction or to the transaction name or the command name itself. The AOI= parameter on the TRANSACT macro contains the controlling specification.

The following table shows the IMS commands that can be issued in an AO application using the CMD call. Each row includes an IMS command, restrictions, and the application environment (MPP or BMP running under DB/DC, or MPP or BMP running under DCCTL).

Table 6. IMS type-1 commands supported from an AO application using CMD

| IMS command | Restrictions                                    | Application environment        |                                |
|-------------|---|--------------------------------|--------------------------------|
|             |   | MPP or BMP running under DB/DC | MPP or BMP running under DCCTL |
| /ACTIVATE   |   | Yes                            | Yes                            |
| /ALLOCATE   |   | Yes                            | Yes                            |
| /ASSIGN     |   | Yes                            | Yes                            |
| /BROADCAST  |   | Yes                            | Yes                            |
| /CHANGE     |   | Yes                            | Yes                            |
| /CHECKPOINT | simple form (no keywords), SNAPQ, or STATISTICS | Yes                            | Yes                            |
| /CLSDST     |   | Yes                            | Yes                            |
| /COMPT      |   | Yes                            | Yes                            |
| /CQCHKPT    |   | Yes                            | Yes                            |
| /CQQUERY    |   | Yes                            | Yes                            |
| /CQSET      |   | Yes                            | Yes                            |
| /DBDUMP     |   | Yes                            | Yes                            |
| /DBRECOVERY |   | Yes                            | Yes                            |
| /DELETE     |   | Yes                            | Yes                            |
| /DEQUEUE    |   | Yes                            | Yes                            |
| /DIAGNOSE   |   | Yes                            | Yes                            |
| /DISPLAY    |   | Yes                            | Yes                            |
| /END        | with keywords                                   | Yes                            | Yes                            |
| /EXCLUSIVE  | with keywords                                   | Yes                            | Yes                            |
| /EXIT       | with LINE and NODE keywords                     | Yes                            | Yes                            |
| /FORMAT     | with LTERM keyword                              | Yes                            | Yes                            |
| /IDLE       |   | Yes                            | Yes                            |
| /INITIATE   | OLREORG   | Yes                            | No                             |
| /LOCK       | without LTERM, NODE, or PTERM keywords          | Yes                            | Yes                            |
| /LOG        |   | Yes                            | Yes                            |
| /LOOPTEST   |   | Yes                            | Yes                            |
| /MONITOR    |   | Yes                            | Yes                            |
| /MSASSIGN   |   | Yes                            | Yes                            |
| /OPNDST     |   | Yes                            | Yes                            |
| /PSTOP      |   | Yes                            | Yes                            |

Table 6. IMS type-1 commands supported from an AO application using CMD (continued)

| IMS command | Restrictions                                   | Application environment        |                                |
|-------------|--|--------------------------------|--------------------------------|
|             |  | MPP or BMP running under DB/DC | MPP or BMP running under DCCTL |
| /PURGE      |  | Yes                            | Yes                            |
| /QUIESCE    |  | Yes                            | Yes                            |
| /RDISPLAY   |  | Yes                            | Yes                            |
| /RECOVER    |  | Yes                            | No                             |
| /RMCHANGE   |  | Yes                            | Yes                            |
| /RMDELETE   |  | Yes                            | Yes                            |
| /RMGENJCL   |  | Yes                            | Yes                            |
| /RMINIT     |  | Yes                            | Yes                            |
| /RMLIST     |  | Yes                            | Yes                            |
| /RMNOTIFY   |  | Yes                            | Yes                            |
| /RSTART     |  | Yes                            | Yes                            |
| /SECURE     |  | Yes                            | Yes                            |
| /SMCOPY     |  | Yes                            | Yes                            |
| /SSR        |  | Yes                            | Yes                            |
| /START      |  | Yes                            | Yes                            |
| /STOP       |  | Yes                            | Yes                            |
| /SWITCH     |  | Yes                            | Yes                            |
| /TERMINATE  | OLREORG  | Yes                            | No                             |
| /TEST MFS   | with LINE/NODE keywords                        | Yes                            | Yes                            |
| /TRACE      |  | Yes                            | Yes                            |
| /UNLOCK     | without LTERM, NODE, PTERM, or SYSTEM keywords | Yes                            | Yes                            |
| /VUNLOAD    |  | Yes                            | No                             |

If the 3270 message facility service (MFS) bypass option is selected, the output message specified is MODNAME=DFSED TN, and the terminal is in preset mode, then the only command recognized by IMS is the **/RESET** command issued from an unformatted screen. All other commands are passed to the application program.

### Issuing IMS type-1 commands by using the ICMD call

The following table shows by application program type the commands that can be issued in an AO application using the ICMD call. This includes DRA thread running under DBCTL or DB/DC; BMP running under DBCTL; MPP, BMP, IFP running under DB/DC; and MPP, BMP, or IFP running under DCCTL. Commands that cause the IMS control region to terminate, such as **/CHE FREEZE**, cannot be issued.

You can secure the commands issued by an ICMD call using RACF (or the equivalent) or the Command Authorization user exit, DFSCCMD0. RACF lets you specify which commands the applications can issue. DFSCCMD0 and RACF let you do authorization checking during ICMD processing. The authorization checking can be controlled either through the transaction name, the command name, or the user ID of the signed on user. The AOI= parameter on the TRANSACT macro allows you to specify which authorization checking is to be used.

Table 7. IMS type-1 commands supported from an AO application using ICMD

| IMS Command               | Application environment                  |                         |                                      |                                      |
|---------------------------|--|-------------------------|--------------------------------------|--------------------------------------|
|                           | DBRA thread running under DBCTL or DB/DC | BMP running under DBCTL | MPP, BMP, or IFP running under DB/DC | MPP, BMP, or IFP running under DCCTL |
| /ACTIVATE                 | N/A                                      | N/A                     | Yes                                  | Yes                                  |
| /ALLOCATE                 | N/A                                      | N/A                     | Yes                                  | Yes                                  |
| /ASSIGN                   | N/A                                      | N/A                     | Yes                                  | Yes                                  |
| /BROADCAST                | N/A                                      | N/A                     | Yes                                  | Yes                                  |
| /CANCEL                   | N/A                                      | N/A                     | No                                   | No                                   |
| /CHANGE                   | Yes                                      | Yes                     | Yes                                  | Yes                                  |
| /CHECKPOINT (simple form) | Yes                                      | Yes                     | Yes                                  | Yes                                  |
| /CHECKPOINT SNAPQ         | N/A                                      | N/A                     | Yes                                  | Yes                                  |
| /CHECKPOINT STATISTICS    | Yes                                      | Yes                     | Yes                                  | Yes                                  |
| /CLSDST                   | N/A                                      | N/A                     | Yes                                  | Yes                                  |
| /COMPT                    | N/A                                      | N/A                     | Yes                                  | Yes                                  |
| /CQCHKPT                  | N/A                                      | N/A                     | Yes                                  | Yes                                  |
| /CQQUERY                  | N/A                                      | N/A                     | Yes                                  | Yes                                  |
| /CQSET                    | N/A                                      | N/A                     | Yes                                  | Yes                                  |
| /DBDUMP                   | Yes                                      | Yes                     | Yes                                  | N/A                                  |
| /DBRECOVERY               | Yes                                      | Yes                     | Yes                                  | N/A                                  |
| /DELETE                   | Yes                                      | Yes                     | Yes                                  | Yes                                  |
| /DEQUEUE                  | Yes                                      | Yes                     | Yes                                  | Yes                                  |
| /DIAGNOSE                 | Yes                                      | Yes                     | Yes                                  | Yes                                  |
| /DISPLAY                  | Yes                                      | Yes                     | Yes                                  | Yes                                  |
| /END                      | N/A                                      | N/A                     | Yes                                  | Yes                                  |
| /ERESTART                 | No                                       | No                      | No                                   | No                                   |
| /EXCLUSIVE                | N/A                                      | N/A                     | Yes                                  | Yes                                  |
| /EXIT                     | N/A                                      | N/A                     | Yes                                  | Yes                                  |
| /FORMAT                   | N/A                                      | N/A                     | Yes                                  | Yes                                  |
| /HOLD                     | N/A                                      | N/A                     | No                                   | No                                   |

Table 7. IMS type-1 commands supported from an AO application using ICMD (continued)

| IMS Command       | Application environment                  |                         |                                      |                                      |
|-------------------|--|-------------------------|--------------------------------------|--------------------------------------|
|                   | DBRA thread running under DBCTL or DB/DC | BMP running under DBCTL | MPP, BMP, or IFP running under DB/DC | MPP, BMP, or IFP running under DCCTL |
| /IDLE             | N/A                                      | N/A                     | Yes                                  | Yes                                  |
| /INITIATE OLREORG | Yes                                      | Yes                     | Yes                                  | No                                   |
| /LOCK DB          | Yes                                      | Yes                     | Yes                                  | N/A                                  |
| /LOCK PGM         | Yes                                      | Yes                     | Yes                                  | Yes                                  |
| /LOCK TRAN        | N/A                                      | N/A                     | Yes                                  | Yes                                  |
| /LOG              | Yes                                      | Yes                     | Yes                                  | Yes                                  |
| /LOOPTEST         | N/A                                      | N/A                     | Yes                                  | Yes                                  |
| /MODIFY           | No                                       | No                      | No                                   | No                                   |
| /MONITOR          | N/A                                      | N/A                     | Yes                                  | Yes                                  |
| /MSASSIGN         | N/A                                      | N/A                     | Yes                                  | Yes                                  |
| /MSVERIFY         | N/A                                      | N/A                     | No                                   | No                                   |
| /NRESTART         | No                                       | No                      | No                                   | No                                   |
| /OPNDST           | N/A                                      | N/A                     | Yes                                  | Yes                                  |
| /PSTOP            | Yes                                      | Yes                     | Yes                                  | Yes                                  |
| /PURGE            | N/A                                      | N/A                     | Yes                                  | Yes                                  |
| /QUIESCE          | N/A                                      | N/A                     | Yes                                  | Yes                                  |
| /RCLSDST          | N/A                                      | N/A                     | No                                   | No                                   |
| /RCOMPT           | N/A                                      | N/A                     | No                                   | No                                   |
| /RDISPLAY         | N/A                                      | N/A                     | Yes                                  | Yes                                  |
| /RECOVER          | Yes                                      | Yes                     | Yes                                  | No                                   |
| /RELEASE          | N/A                                      | N/A                     | No                                   | No                                   |
| /RESET            | N/A                                      | N/A                     | No                                   | No                                   |
| /RMCHANGE         | Yes                                      | Yes                     | Yes                                  | Yes                                  |
| /RMDELETE         | Yes                                      | Yes                     | Yes                                  | Yes                                  |
| /RMGENJCL         | Yes                                      | Yes                     | Yes                                  | Yes                                  |
| /RMINIT           | Yes                                      | Yes                     | Yes                                  | Yes                                  |
| /RMLIST           | Yes                                      | Yes                     | Yes                                  | Yes                                  |
| /RMNOTIFY         | Yes                                      | Yes                     | Yes                                  | Yes                                  |
| /RSTART           | N/A                                      | N/A                     | Yes                                  | Yes                                  |
| /RTAKEOVER        | No                                       | No                      | No                                   | No                                   |
| /SECURE           | N/A                                      | N/A                     | Yes                                  | Yes                                  |
| /SET              | N/A                                      | N/A                     | No                                   | No                                   |

Table 7. IMS type-1 commands supported from an AO application using ICMD (continued)

| IMS Command                       | Application environment                  |                         |                                      |                                      |
|-----------------------------------|--|-------------------------|--------------------------------------|--------------------------------------|
|                                   | DBRA thread running under DBCTL or DB/DC | BMP running under DBCTL | MPP, BMP, or IFP running under DB/DC | MPP, BMP, or IFP running under DCCTL |
| /SIGN                             | N/A                                      | N/A                     | No                                   | No                                   |
| /SMCOPY                           | N/A                                      | N/A                     | Yes                                  | Yes                                  |
| /SSR                              | No                                       | Yes                     | Yes                                  | Yes                                  |
| /START                            | Yes                                      | Yes                     | Yes                                  | Yes                                  |
| /STOP                             | Yes                                      | Yes                     | Yes                                  | Yes                                  |
| /SWITCH                           | Yes                                      | Yes                     | Yes                                  | Yes                                  |
| /TERMINATE<br>OLREORG             | Yes                                      | Yes                     | Yes                                  | No                                   |
| /TEST MFS LINE or<br>NODE or USER | N/A                                      | N/A                     | Yes                                  | Yes                                  |
| /TRACE                            | Yes                                      | Yes                     | Yes                                  | Yes                                  |
| /UNLOCK DB                        | Yes                                      | Yes                     | Yes                                  | N/A                                  |
| /UNLOCK PGM                       | Yes                                      | Yes                     | Yes                                  | Yes                                  |
| /UNLOCK TRAN                      | N/A                                      | N/A                     | Yes                                  | Yes                                  |
| /VUNLOAD                          | Yes                                      | Yes                     | Yes                                  | N/A                                  |

The following commands and keywords are not permitted:

- **/CHECKPOINT** keywords ABDUMP, DUMPQ, FREEZE, PURGE, and QUIESCE
- The commands **/END**, **/EXIT**, and **/EXCLUSIVE** if they have no keywords
- **/LOCK** keywords LTERM, NODE, and PTERM
- **/UNLOCK** keywords LTERM, NODE, PTERM, and SYSTEM

#### Related concepts

[Tools for automated operations \(Operations and Automation\)](#)

[Security for AO application programs \(System Administration\)](#)

## Command security when using OM

For IMS command security, you have your choice of OM command security using RACF or equivalent, or IMS command security.

**Recommendation:** Use OM command security instead of IMS security.

By allowing OM to perform the security checks, commands which fail security authorization are not routed to IMS, reducing processing overhead and network traffic. When IMS command security is used, it is up to the user to ensure that all IMS systems use the same security profiles or user exits. If IMS systems in the same IMSplex use different security rules, the results of command security checking may be unpredictable.

#### Related reference

[IMS commands, RACF access authorities and resource names table \(System Administration\)](#)

## Commands mirrored on an XRF alternate

Certain commands that successfully alter IMS resources are written to the system log as X'02' or X'22' log records.

IMS type-1 commands that alter resources write an X'02' log record. Type-2 commands that alter resources write an X'22' log record. In an XRF environment, the X'02' or X'22' log records are read and processed by the alternate system as it tracks the active system. The effect of these commands is mirrored on the alternate system when it takes over and becomes the active system. These commands, along with exceptions, are listed in the following table.

Table 8. List of IMS commands mirrored on an XRF alternate

| Command    | Exceptions   |
|------------|--|
| /ASSIGN    | /ASSIGN is mirrored only if the assignment does not involve the master terminal.   |
| /CHANGE    |  |
| CREATE     |  |
| /DELETE    |  |
| DELETE     |  |
| /END       |  |
| /EXCLUSIVE |  |
| /EXIT      |  |
| /HOLD      |  |
| /LOCK      |  |
| /LOG       |  |
| /MONITOR   |  |
| /MSASSIGN  |  |
| /PSTOP     | /PSTOP REGION  |
| /PURGE     | /PURGE APPC  |
| /RELEASE   |  |
| /RESET     |  |
| /RSTART    |  |
| /SECURE    | /SECURE APPC   |
| /SET       |  |
| /SMCOPY    |  |
| /START     | /START APPC, /START REGION   |
| /STOP      | /STOP APPC, /STOP REGION   |
| /TEST      | /TEST is usually not mirrored on an XRF alternate system. However, /TEST MFS is mirrored if the alternate system is tracking the state of the terminal that entered the /TEST MFS command. |

Table 8. List of IMS commands mirrored on an XRF alternate (continued)

| Command         | Exceptions  |
|-----------------|---|
| /TRACE          | /TRACE is usually not mirrored on an XRF alternate system. However, /TRACE SET LINE and /TRACE SET LINK are mirrored for lines and links that can be restarted. /TRACE SET NODE is mirrored for all node types. |
| /UNLOCK         | /UNLOCK SYSTEM  |
| UPDATE DB       |   |
| UPDATE DBDESC   |   |
| UPDATE MSLINK   |   |
| UPDATE MSNAME   |   |
| UPDATE MSPLINK  |   |
| UPDATE PGM      |   |
| UPDATE PGMDESC  |   |
| UPDATE RTC      |   |
| UPDATE RTCDESC  |   |
| UPDATE TRAN     | UPDATE TRAN START(TRACE), UPDATE TRAN STOP(TRACE)   |
| UPDATE TRANDESC |   |

## Commands supported on the XRF alternate

The commands that are valid on the XRF alternate, along with the exceptions, are shown in the following table.

Table 9. List of commands supported on the XRF alternate

| Command       | Exceptions    |
|---------------|---------------|
| /ACTIVATE     |               |
| /CANCEL       |               |
| /CHANGE       |               |
| /CLSDST       |               |
| /COMPT        |               |
| /DISPLAY      | /DISPLAY QCNT |
| /END          |               |
| /ERESTART     |               |
| /FORMAT       |               |
| /IDLE         |               |
| /NRESTART     |               |
| /OPNDST       |               |
| /PSTOP REGION |               |
| QUERY AREA    |               |



Table 9. List of commands supported on the XRF alternate (continued)

| <b>Command</b> | <b>Exceptions</b>   |
|----------------|---|
| QUERY DB       | QUERY DB SHOW(WORK)<br>QUERY DB SHOW(DEFN)<br>QUERY DB SHOW(DEFN,IMSID)<br>QUERY DB SHOW(DEFN,GLOBAL)<br>QUERY DB SHOW(IMSID)           |
| QUERY DBDESC   | QUERY DBDESC SHOW(DEFN)<br>QUERY DBDESC SHOW(DEFN,IMSID)<br>QUERY DBDESC SHOW(DEFN,GLOBAL)<br>QUERY DBDESC SHOW(IMSID)                  |
| QUERY IMS      |   |
| QUERY IMSPLEX  |   |
| QUERY LTERM    | QUERY LTERM SHOW(GLOBAL)  |
| QUERY MEMBER   |   |
| QUERY NODE     | QUERY NODE SHOW(GLOBAL)   |
| QUERY OTMADESC |   |
| QUERY OTMATI   |   |
| QUERY PGM      | QUERY PGM SHOW(WORK)<br>QUERY PGM SHOW(DEFN)<br>QUERY PGM SHOW(DEFN,IMSID)<br>QUERY PGM SHOW(DEFN,GLOBAL)<br>QUERY PGM SHOW(IMSID)      |
| QUERY PGMDESC  | QUERY PGMDESC SHOW(DEFN)<br>QUERY PGMDESC SHOW(DEFN,IMSID)<br>QUERY PGMDESC SHOW(DEFN,GLOBAL)<br>QUERY PGMDESC SHOW(IMSID)              |
| QUERY RTC      | QUERY RTC SHOW(WORK)<br>QUERY RTC SHOW(DEFN)<br>QUERY RTC SHOW(DEFN,IMSID)<br>QUERY RTC SHOW(DEFN,GLOBAL)<br>QUERY RTC SHOW(IMSID)      |
| QUERY RTCDESC  | QUERY RTCDESC SHOW(DEFN)<br>QUERY RTCDESC SHOW(DEFN,IMSID)<br>QUERY RTCDESC SHOW(DEFN,GLOBAL)<br>QUERY RTCDESC SHOW(IMSID)              |
| QUERY TRAN     | QUERY TRAN SHOW(WORK)<br>QUERY TRAN SHOW(DEFN)<br>QUERY TRAN SHOW(DEFN,IMSID)<br>QUERY TRAN SHOW(DEFN,GLOBAL)<br>QUERY TRAN SHOW(IMSID) |

Table 9. List of commands supported on the XRF alternate (continued)

| Command                       | Exceptions   |
|-------------------------------|--|
| QUERY TRANDESC                | QUERY TRANDESC SHOW(DEFN)<br>QUERY TRANDESC SHOW(DEFN,IMSID)<br>QUERY TRANDESC SHOW(DEFN,GLOBAL)<br>QUERY TRANDESC SHOW(IMSID) |
| QUERY USER                    | QUERY USER SHOW(GLOBAL)  |
| /RCLSDST                      |  |
| /RCOMPT                       |  |
| /RDISPLAY                     |  |
| REFRESH USEREXIT              |  |
| /RMLIST                       |  |
| /SECURE                       |  |
| /SMCOPY                       |  |
| /START DC                     |  |
| /START LUNAME                 |  |
| /START REGION                 |  |
| /START RTCODE                 |  |
| /START SURVEILLANCE           |  |
| /STOP                         |  |
| /STOP BACKUP                  |  |
| /STOP DC                      |  |
| /STOP LUNAME                  |  |
| /STOP REGION                  |  |
| /STOP RTCODE                  |  |
| /STOP SURVEILLANCE            |  |
| /SWITCH                       |  |
| /TEST                         |  |
| /TRACE                        |  |
| UPDATE MSLINK TKOTRC()        |  |
| UPDATE TRAN SET(MAXRGN)       |  |
| UPDATE TRAN START STOP(TRACE) |  |

## IMS type-1 commands supported from LU 6.2 devices and OTMA

Only certain IMS type-1 commands are valid from LU 6.2 devices and OTMA.

The IMS type-1 commands that are supported from LU 6.2 devices and OTMA are listed in the following table:

Table 10. IMS type-1 commands supported from LU 6.2 devices and OTMA

| Commands    | Commands (continued) |
|-------------|----------------------|
| /ALLOCATE*  | /PURGE               |
| /ASSIGN     | /QUIESCE             |
| /BROADCAST* | /RDISPLAY            |
| /CHANGE*    | /RMCHANGE*           |
| /CHECKPOINT | /RMDELETE*           |
| /CLSDST     | /RMGENJCL*           |
| /COMPT      | /RMINIT*             |
| /DBDUMP     | /RMLIST*             |
| /DBRECOVERY | /RMNOTIFY*           |
| /DELETE     | /RSTART              |
| /DEQUEUE    | /SECURE              |
| /DIAGNOSE   | /SMCOPY              |
| /DISPLAY    | /SSR                 |
| /IDLE       | /START               |
| /LOG        | /STOP                |
| /LOCK       | /SWITCH              |
| /MODIFY     | /TRACE               |
| /MONITOR    | /UNLOCK              |
| /MSASSIGN   |                      |
| /MSVERIFY   |                      |
| /OPNDST*    |                      |
| /PSTOP      |                      |

**Note:** \* Multisegment commands are not supported by OTMA.

## Terminal security defaults for LU 6.2 devices and OTMA

Only some IMS type-1 commands from LU 6.2 devices and OTMA are authorized in an environment in which RACF is not used (RACF=NONE) and the command security exit (DFSCCMD0) is also not used.

The following table shows the terminal security defaults for IMS type-1 commands from LU 6.2 devices and OTMA when RACF is not used (RACF=NONE) and the command security exit (DFSCCMD0) is also not used. Only the commands shown in the table will be authorized in these environments.

Table 11. Terminal security defaults for IMS type-1 commands from LU 6.2 devices and OTMA

| LU 6.2 Devices | OTMA      |
|----------------|-----------|
| /BROADCAST     | /LOC      |
| /LOC           | /LOG      |
| /LOG           | /RDISPLAY |

Table 11. Terminal security defaults for IMS type-1 commands from LU 6.2 devices and OTMA (continued)

| LU 6.2 Devices | OTMA |
|----------------|------|
| /RDISPLAY      |      |
| /RMLIST        |      |

## Commands and keywords supported by the OM API

Some IMS commands are supported by the OM API.

The following table is a list of IMS command verbs and primary keywords that can be issued through the Operations Manager (OM) API. The command verb can be specified in the long form or short form, as specified in columns one and two. The primary keyword is the first keyword that follows the command verb, as specified in column three.

**Restriction:** The OM API supports only the short form of the keywords that are described in the following table. For example, the keyword ACTIVE (used on the **/BROADCAST** command) has a short form of ACT. The OM API supports only the ACT keyword, not ACTIVE.

Table 12. Commands supported by the OM API

| Command (long form) | Command (short form) | Primary keywords (short form)  |
|---------------------|----------------------|--|
| /ACTIVATE           | /ACT                 | LINK, NODE   |
| /ALLOCATE           | /ALL                 | LU   |
| /ASSIGN             | /ASS                 | CLASS, CPRI, INPUT, LCT, LPRI, LTERM, NPRI, OUTPUT, PARLIM, PLCT, SEGNO, SEGSZ, TRAN, USER               |
| /BROADCAST          | /BRO                 | ACT, LINE, LTERM, MASTER, NODE, PTERM, USER  |
| /CHANGE             | /CHA                 | APPC, CCTL, CPLOG, DESC, DIR, FDR, LINK, NODE, PSWD, SUBSYS, SURV, TRAN, UOR, USER                       |
| /CHECKPOINT         | /CHE                 | DUMPQ, FREEZE, PURGE, STATISTICS   |
| /CLSDST             | /CLS                 | NODE   |
| /CQCHKPT            | /CQC                 | SHAREDQ, SYSTEM  |
| /CQQUERY            | /CQQ                 | STATISTICS   |
| /CQSET              | /CQS                 | SHUTDOWN   |
| CREATE              | CRE                  | DB, DBDESC, IMSCON, LTERM, MSLINK, MSPLINK, MSNAME, OTMADESC, PGM, PGMDESC, RTC, RTCDESC, TRAN, TRANDESC |
| /DBDUMP             | /DBD                 | DB   |
| /DBRECOVERY         | /DBR                 | AREA, DB, DATAGRP  |
| /DELETE             | /DEL                 | DESC, PSWD, TERMINAL   |
| DELETE              | DEL                  | DB, DBDESC, DEFN, LE, OTMADESC, PGM, PGMDESC, RTC, RTCDESC, TRAN, TRANDESC                               |

Table 12. Commands supported by the OM API (continued)

| <b>Command (long form)</b> | <b>Command (short form)</b> | <b>Primary keywords (short form)</b>  |
|----------------------------|-----------------------------|---|
| /DEQUEUE                   | /DEQ                        | AOITKN, LINE, LTERM, LU, MSNAME, NODE, SUSPEND, TMEM, TRAN, USER  |
| /DISPLAY                   | /DIS                        | ACT, AFFIN, AOITKN, APPC, AREA, ASMT, CCTL, CONV, CPLOG, CQS, DB, DBD, DESC, FDR, FPV, HSB, HSSP, LINE, LINK, LTERM, LU, MASTER, MODIFY, MSNAME, NODE, OASN, OLDS, OTMA, OVERFLOWQ, PGM, POOL, PSB, PTERM, Q, QCNT, RECOVERY, RTC, SHUTDOWN, STATUS, STRUC, SUBSYS, SYSID, TIMEOVER, TMEM, TRACE, TRACKING, TRAN, UOR, USER |
| /END                       | /END                        | LINE, NODE, USER  |
| /ERESTART                  | /ERE                        | BACKUP, COLDBASE, COLDCOMM, COLDSYS, <i>NULL</i>  |
| /EXCLUSIVE                 | /EXC                        | LINE, NODE, USER  |
| /EXIT                      | /EXI                        | CONV  |
| EXPORT                     | EXP                         | DEFN  |
| /IDLE                      | /IDL                        | LINE, LINK, NODE  |
| IMPORT                     | IMP                         | DEFN  |
| INITIATE                   | INIT                        | OLC, OLREORG  |
| /LOCK                      | /LOC                        | DB, PGM, TRAN   |
| /LOG                       | /LOG                        |   |
| /MODIFY                    | /MOD                        | ABORT, COMMIT, PREPARE  |
| /MONITOR                   | /MON                        | LINE  |
| /MSASSIGN                  | /MSA                        | LINK, MSNAME, SYSID, TRAN   |
| /NRESTART                  | /NRE                        | CHKPT, <i>NULL</i>  |
| /OPNDST                    | /OPN                        | NODE  |
| /PSTOP                     | /PST                        | LINE, LINK, LTERM, MSPLINK, REGION, TRAN  |
| /PURGE                     | /PUR                        | APPC, FPPROG, FPRGN, LINE, LTERM, MSNAME, TRAN  |

Table 12. Commands supported by the OM API (continued)

| Command (long form) | Command (short form) | Primary keywords (short form)  |
|---------------------|----------------------|--|
| QUERY               | QRY                  | AREA, DB, DBDESC, IMS, IMSCON, IMSPLEX, LE, LTERM, MEMBER, MSLINK, MSNAME, MSPLINK, NODE, ODBM, OLC, OLREORG, OTMADESC, OTMATI, PGM, PGMDESC, POOL, RTC, RTCDESC, STRUCTURE, TRAN, TRANDESC, USER, USEREXIT, USERID          |
| QUEUE               | QUE                  | LTERM, TRAN  |
| /QUIESCE            | /QUI                 | NODE   |
| /RDISPLAY           | /RDI                 | MASTER   |
| /RECOVER            | /REC                 | ADD, REMOVE, START, STOP, TERMINATE  |
| REFRESH             | —                    | USEREXIT   |
| /RMCHANGE           | /RMC                 |  |
| /RMDELETE           | /RMD                 |  |
| /RMGENJCL           | /RMG                 |  |
| /RMINIT             | /RMI                 |  |
| /RMLIST             | /RML                 |  |
| /RMNOTIFY           | /RMN                 |  |
| /RSTART             | /RST                 | LINE, LINK, MSPLINK, NODE, USER  |
| /RTAKEOVER          | /RTA                 | DUMPQ, FREEZE, UNPLAN  |
| /SECURE             | /SEC                 | APPC, OTMA   |
| /SMCOPY             | /SMC                 | MASTER, MSG, TERMINAL  |
| /START              | /STA                 | APPC, AREA, AUTOARCH, CLASS, DATAGRP, DB, DC, DESC, ISOLOG, LINE, LTERM, LU, MADSIOT, MSNAME, NODE, OLDS, OTMA, PGM, REGION, RTC, SB, SERVGRP, SLDSREAD, SUBSYS, SURV, THREAD, TMEM, TRAN, TRKARCH, USER, VGR, WADS, XRCTACK |
| /STOP               | /STO                 | ADS, APPC, AREA, AUTOARCH, BACKUP, CLASS, DATAGRP, DB, DC, LINE, LTERM, LU, MADSIOT, MSNAME, NODE, OLDS, OTMA, PGM, REGION, RTC, SB, SERVGRP, SLDSREAD, SUBSYS, SURV, THREAD, TMEM, TRAN, USER, VGR, WADS, XRCTACK           |

Table 12. Commands supported by the OM API (continued)

| Command (long form) | Command (short form) | Primary keywords (short form)  |
|---------------------|----------------------|--|
| /SWITCH             | /SWI                 | OLDS, SYSTEM, WADS   |
| TERMINATE           | TERM                 | OLC, OLREORG   |
| /TEST               | /TES                 | MFS  |
| /TRACE              | /TRA                 | SET  |
| /UNLOCK             | /UNL                 | DB, PGM, SYSTEM, TRAN  |
| UPDATE              | UPD                  | AREA, DATAGRP, DB, DBDESC, IMS, IMSCON, LE, MSLINK, MSNAME, MSPLINK, ODBM, OLREORG, OTMADESC, PGM, PGMDESC, POOL, RTC, RTCDESC, TRAN, TRANDESC |
| /VUNLOAD            | /VUN                 | AREA   |

## Equivalent IMS type-1 and type-2 commands

Certain IMS type-1 commands and type-2 commands perform similar tasks.

The following table shows the different instances of the IMS type-1 commands and type-2 commands that perform similar tasks.

Table 13. Type-2 equivalents for the /ASSIGN command

| Task  | /ASSIGN command   | Similar IMS type-2 command  |
|---|---|---|
| Changes the value for the limit count of a transaction.   | /ASSIGN LCT <i>new_lmct_number</i> TO TRAN <i>tranname</i>      | UPDATE TRAN NAME( <i>tranname</i> )<br>SET(LCT( <i>new_limit_count</i> ))       |
| Changes the value for the limit priority of a transaction.  | /ASSIGN LPRI <i>new_lpri_number</i> TO TRAN <i>tranname</i>     | UPDATE TRAN NAME( <i>tranname</i> )<br>SET(LPRI( <i>new_limit_priority</i> ))   |
| Changes the value for the normal priority of a transaction.   | /ASSIGN NPRI <i>new_npri_number</i> TO TRAN <i>tranname</i>     | UPDATE TRAN NAME( <i>tranname</i> )<br>SET(NPRI( <i>new_normal_priority</i> ))  |
| Changes the value for the parallel processing limit count of a transaction.   | /ASSIGN PARLIM <i>new_parlim_number</i> TO TRAN <i>tranname</i> | UPDATE TRAN NAME( <i>tranname</i> )<br>SET(PARLIM( <i>new_parallel_limit</i> )) |
| Changes the value for the processing limit count of a transaction.  | /ASSIGN PLCT <i>new_plmct_number</i> TO TRAN <i>tranname</i>    | UPDATE TRAN NAME( <i>tranname</i> )<br>SET(PLCT( <i>new_processing_limit</i> )) |
| Changes the limit on the number of application program output segments allowed in message queues for each GU call.          | /ASSIGN SEGNO <i>new_segno_number</i> TO TRAN <i>tranname</i>   | UPDATE TRAN NAME( <i>tranname</i> )<br>SET(SEGNO( <i>new_segment_number</i> ))  |
| Creates or changes the limit on the size of application program output segments allowed in message queues for each GU call. | /ASSIGN SEGSZ <i>new_segsize_number</i> TO TRAN <i>tranname</i> | UPDATE TRAN NAME( <i>tranname</i> )<br>SET(SEGSZ( <i>new_segment_size</i> ))    |
| Changes the class number of a transaction.  | /ASSIGN TRAN <i>tranname</i> TO CLS <i>new_class_number</i>     | UPDATE TRAN NAME( <i>tranname</i> )<br>SET(CLASS( <i>new_class_number</i> ))    |

Table 14. Type-2 equivalents for the /DBDUMP command

| Task                         | /DBDUMP command          | Similar IMS type-2 command   |
|------------------------------|--------------------------|--|
| Stops updates to a database. | /DBDUMP DB <i>dbname</i> | UPDATE DB NAME( <i>dbname</i> )<br>STOP(UPDATES) OPTION(FEOV) <sup>1</sup> |

<sup>1</sup> This command does not automatically issue checkpoints unless OPTION(FEOV) is specified.

Table 15. Type-2 equivalents for the /DBRECOVERY command

| Task   | /DBRECOVERY command                       | Similar IMS type-2 command  |
|--|---|---|
| Stops the accessing and updating of an area.                                   | /DBRECOVERY AREA <i>areaname</i>          | UPDATE AREA NAME( <i>areaname</i> )<br>STOP(ACCESS)                       |
| Stops the accessing and updating of all areas and databases of the data group. | /DBRECOVERY DATAGRP<br><i>datagrpname</i> | UPDATE DATAGRP<br>NAME( <i>datagrpname</i> )<br>STOP(ACCESS)              |
| Stops access to the database and take it offline.                              | /DBRECOVERY DB <i>dbname</i>              | UPDATE DB NAME( <i>dbname</i> )<br>STOP(ACCESS) OPTION(FEOV) <sup>1</sup> |

<sup>1</sup> This command does not automatically issue checkpoints unless OPTION(FEOV) is specified.

Table 16. Type-2 equivalents for the /DISPLAY AFFIN command

| Task   | /DISPLAY AFFIN command           | Similar IMS type-2 command                     |
|--|----------------------------------|--|
| Displays TCP/IP generic resource affinities. | /DISPLAY AFFIN LINK <i>links</i> | QUERY MSLINK NAME(linkname   *)<br>SHOW(AFFIN) |
| Displays VTAM generic resource affinities.   | /DISPLAY AFFIN NODE <i>node</i>  | QUERY NODE SHOW(AFFIN)                         |

Table 17. Type-2 equivalents for the /DISPLAY AREA command

| Task                                | /DISPLAY AREA command | Similar IMS type-2 command |
|-------------------------------------|-----------------------|----------------------------|
| Displays information about an area. | /DISPLAY AREA         | QUERY AREA                 |

Table 18. Type-2 equivalents for the /DISPLAY ASMT command

| Task  | /DISPLAY ASMT command                       | Similar IMS type-2 command     |
|---|---|--------------------------------|
| Displays input and output components.           | /DISPLAY ASMT LTERM <i>ltermname</i>        | QUERY LTERM<br>SHOW(COMPONENT) |
| Displays the node associated with the lterm.    | /DISPLAY ASMT LTERM <i>ltermname</i>        | QUERY LTERM SHOW(NODE)         |
| Displays the user associated with the lterm.    | /DISPLAY ASMT LTERM <i>ltermname</i>        | QUERY LTERM SHOW(USER)         |
| Displays the attributes of an MSC logical link  | /DISPLAY ASMT MSPLINK<br><i>msplinkname</i> | QUERY MSLINK SHOW(ALL)         |
| Displays the attributes of an MSC physical link | /DISPLAY ASMT MSPLINK<br><i>msplinkname</i> | QUERY MSPLINK SHOW(ALL)        |
| Displays assigned lterms.                       | /DISPLAY ASMT NODE <i>node</i>              | QUERY NODE SHOW(LTERM)         |
| Displays the user associated with the node.     | /DISPLAY ASMT NODE <i>node</i>              | QUERY NODE SHOW(USER)          |



Table 18. Type-2 equivalents for the /DISPLAY ASMT command (continued)

| Task  | /DISPLAY ASMT command          | Similar IMS type-2 command                       |
|---|--------------------------------|--|
| Displays the other half-session qualifier ID of the ISC node. | /DISPLAY ASMT USER <i>user</i> | QUERY USER SHOW(ID)                              |
| Displays assigned lterms.                                     | /DISPLAY ASMT USER <i>user</i> | QUERY USER SHOW(LTERM)                           |
| Displays the node.  | /DISPLAY ASMT USER <i>user</i> | QUERY USER SHOW(NODE)<br>QUERY USERID SHOW(NODE) |
| Displays the user ID.   | /DISPLAY ASMT USER <i>user</i> | QUERY USER SHOW(USERID)                          |
| Displays the user.  | /DISPLAY ASMT USER <i>user</i> | QUERY USERID SHOW(USER)                          |

Table 19. Type-2 equivalents for the /DISPLAY CONV command

| Task   | /DISPLAY CONV command          | Similar IMS type-2 command |
|--|--------------------------------|----------------------------|
| Displays nodes with active or held conversations.            | /DISPLAY CONV                  | QUERY NODE STATUS(CONV)    |
| Displays users with active or held conversations.            | /DISPLAY CONV                  | QUERY USER STATUS(CONV)    |
| Displays IMS conversation information for a particular node. | /DISPLAY CONV NODE <i>node</i> | QUERY NODE SHOW(CONV)      |
| Displays IMS conversation information for a particular user. | /DISPLAY CONV USER <i>user</i> | QUERY USER SHOW(CONV)      |

Table 20. Type-2 equivalents for the /DISPLAY DB command

| Task                               | /DISPLAY DB command                            | Similar IMS type-2 command |
|------------------------------------|--|----------------------------|
| Displays the status of a database. | /DISPLAY DB <i>dbname1 ...dbnamen</i><br>  ALL | QUERY DB                   |

Table 21. Type-2 equivalents for the /DISPLAY DBD command

| Task   | /DISPLAY DBD command        | Similar IMS type-2 command                  |
|--|-----------------------------|---|
| Displays the programs being accessed by databases. | /DISPLAY DBD <i>dbdname</i> | QUERY DB NAME( <i>dbname</i> )<br>SHOW(PGM) |

Table 22. Type-2 equivalents for the /DISPLAY LTERM command

| Task  | /DISPLAY LTERM command  | Similar IMS type-2 command |
|---|---|----------------------------|
| Displays logical link path for remote lterms. | /DISPLAY LTERM <i>ltermname</i>   | QUERY LTERM SHOW(MSNAME)   |
| Displays the lterm message queue count.       | /DISPLAY LTERM <i>ltermname</i><br>/DISPLAY LTERM <i>ltermname</i> QCNT | QUERY LTERM SHOW(QCNT)     |
| Displays status of the lterm.                 | /DISPLAY LTERM <i>ltermname</i>   | QUERY LTERM SHOW(STATUS)   |
| Displays queue count in the EMH queues.       | /DISPLAY LTERM <i>ltermname</i> QCNT<br>EMHQ                            | QUERY LTERM SHOW(EMHQ)     |

Table 23. Type-2 equivalents for the /DISPLAY MASTER command

| Task  | /DISPLAY MASTER command | Similar IMS type-2 command   |
|---|-------------------------|------------------------------|
| Displays the primary and secondary master terminal. | /DISPLAY MASTER         | QUERY LTERM STATUS(MTO,SMTO) |

Table 24. Type-2 equivalents for the /DISPLAY MODIFY command

| Task   | /DISPLAY MODIFY command | Similar IMS type-2 command                       |
|--|-------------------------|--|
| Displays work in progress for runtime resource definitions that would cause a <b>DELETE</b> , / <b>MODIFY COMMIT</b> , <b>INITIATE OLC PHASE (COMMIT)</b> , or <b>UPDATE</b> command to change resource definitions to fail. | /DISPLAY MODIFY ALL     | QUERY DB NAME( <i>dbname</i> )<br>SHOW(WORK)     |
|  |                         | QUERY PGM NAME( <i>pgmname</i> )<br>SHOW(WORK)   |
|  |                         | QUERY RTC NAME( <i>rtcode</i> )<br>SHOW(WORK)    |
|  |                         | QUERY TRAN NAME( <i>tranname</i> )<br>SHOW(WORK) |

Table 25. Type-2 equivalents for the /DISPLAY NODE command

| Task  | /DISPLAY NODE command                                       | Similar IMS type-2 command |
|---|---|----------------------------|
| Displays VTAM connection identifier (CID).                                  | /DISPLAY NODE <i>node</i>                                   | QUERY NODE SHOW(CID)       |
| Displays send/receive message counts.                                       | /DISPLAY NODE <i>node</i>                                   | QUERY NODE SHOW(COUNT)     |
| Displays preset destination.  | /DISPLAY NODE <i>node</i>                                   | QUERY NODE SHOW(PRESET)    |
| Displays queue count.   | /DISPLAY NODE <i>node</i><br>/DISPLAY NODE <i>node</i> QCNT | QUERY NODE SHOW(QCNT)      |
| Displays status for a particular node.                                      | /DISPLAY NODE <i>node</i>                                   | QUERY NODE SHOW(STATUS)    |
| Displays terminal type.   | /DISPLAY NODE <i>node</i>                                   | QUERY NODE SHOW(TYPE)      |
| Displays user ID.   | /DISPLAY NODE <i>node</i>                                   | QUERY NODE SHOW(USERID)    |
| Displays user.  | /DISPLAY NODE <i>node</i>                                   | QUERY NODE SHOW(USER)      |
| Displays VTAM mode table names.   | /DISPLAY NODE <i>node</i> MODE                              | QUERY NODE SHOW(MODETBL)   |
| Displays message queue count in the Expedited Message Handler (EMH) queues. | /DISPLAY NODE <i>node</i> QCNT EMHQ                         | QUERY NODE SHOW(EMHQ)      |
| Displays owner IMSID in RM resource structure.                              | /DISPLAY NODE <i>node</i> RECOVERY                          | QUERY NODE SHOW(OWNER)     |
| Displays status recovery information.                                       | /DISPLAY NODE <i>node</i> RECOVERY                          | QUERY NODE SHOW(RECOVERY)  |

Table 26. Type-2 equivalents for the /DISPLAY PGM command

| Task                                  | /DISPLAY PGM command        | Similar IMS type-2 command                     |
|---------------------------------------|-----------------------------|--|
| Displays information about a program. | /DISPLAY PGM <i>pgmname</i> | QRY PGM NAME( <i>pgmname</i> )<br>SHOW(ALL)    |
|                                       |                             | QUERY PGM NAME( <i>pgmname</i> )<br>SHOW(TRAN) |

Table 27. Type-2 equivalents for the /DISPLAY POOL command

| Task   | /DISPLAY POOL command | Similar IMS type-2 command                |
|--|-----------------------|---|
| Displays processor storage utilization statistics for OSAM and VSAM database buffer pools. | /DISPLAY POOL DBAS    | QUERY POOL TYPE(DBAS)<br>SHOW(STATISTICS) |

Table 28. Type-2 equivalents for the /DISPLAY PSB command

| Task   | /DISPLAY PSB command        | Similar IMS type-2 command                     |
|--|-----------------------------|--|
| Displays transactions, routing codes, and databases associated with a PSB. | /DISPLAY PSB <i>psbname</i> | QUERY PGM NAME( <i>pgmname</i> )<br>SHOW(DB)   |
|  |                             | QUERY PGM NAME( <i>pgmname</i> )<br>SHOW(RTC)  |
|  |                             | QUERY PGM NAME( <i>pgmname</i> )<br>SHOW(TRAN) |

Table 29. Type-2 equivalents for the /DISPLAY QCNT command

| Task   | /DISPLAY QCNT command               | Similar IMS type-2 command     |
|--|-------------------------------------|--------------------------------|
| Displays lterms with messages that are older than the specified age (shared queues). | /DISPLAY QCNT LTERM MSGAGE <i>x</i> | QUERY LTERM MSGAGE( <i>x</i> ) |

Table 30. Type-2 equivalents for the /DISPLAY RTC command

| Task  | /DISPLAY RTC command                             | Similar IMS type-2 command                                       |
|---|--|--|
| Displays information about one or more Fast Path routing codes. | /DISPLAY RTC <i>rtcname1...rtcnamen</i><br>  ALL | QUERY RTC<br>NAME( <i>rtcname1,...rtcnamen</i>   *)<br>SHOW(ALL) |

Table 31. Type-2 equivalents for the /DISPLAY STATUS command

| Task  | /DISPLAY STATUS command | Similar IMS type-2 command   |
|---|-------------------------|--|
| Displays information about databases with the specified status. | /DISPLAY STATUS DB      | QUERY DB STATUS(ALLOCF,<br>ALLOCS,BACKOUT,EEQE,<br>LOCK,NOTINIT,NOTOPEN,<br>OLR,OPEN,RECALL,RECOV,<br>RNL,STOSCHD,STOUPDS) |
| Displays status.  | /DISPLAY STATUS LTERM   | QUERY LTERM SHOW(STATUS)   |
| Displays logical terminals with specified status.               | /DISPLAY STATUS LTERM   | QUERY LTERM STATUS(status)<br>SHOW(STATUS)   |

Table 31. Type-2 equivalents for the /DISPLAY STATUS command (continued)

| <b>Task</b>  | <b>/DISPLAY STATUS command</b> | <b>Similar IMS type-2 command</b>  |
|--|--------------------------------|--|
| Displays nodes with specified status.  | /DISPLAY STATUS NODE           | QUERY NODE STATUS(status)  |
| Displays all programs that have status and what that status is.                | /DISPLAY STATUS PGM            | QUERY PGM STATUS(DB-NOTAVL, IOPREV,LOCK,NOTINIT, STOSCHD,TRACE)              |
| Displays all Fast Path routing codes that have status and what that status is. | /DISPLAY STATUS RTC            | QUERY RTC STATUS(ACTIVE,NOTINIT, NOTSCHD,STOQ)                               |
| Displays information about transactions with the specified status.             | /DISPLAY STATUS TRANSACTION    | QUERY TRAN NAME(traname) STATUS (IOPREV,LCK,QERR,SUSPEND, STOQ,STOSCHD,USTO) |
| Displays users with specified status.  | /DISPLAY STATUS USER           | QUERY USER STATUS(status)  |

Table 32. Type-2 equivalents for the /DISPLAY TRACE command

| <b>Task</b>                       | <b>/DISPLAY TRACE command</b> | <b>Similar IMS type-2 command</b> |
|-----------------------------------|-------------------------------|-----------------------------------|
| Displays nodes with trace status. | /DISPLAY TRACE NODE           | QUERY NODE STATUS(TRACE)          |

Table 33. Type-2 equivalents for the /DISPLAY TRAN command

| <b>Task</b>  | <b>/DISPLAY TRAN command</b>      | <b>Similar IMS type-2 command</b>            |
|--|-----------------------------------|--|
| Displays information about a transaction.  | /DISPLAY TRAN <i>traname</i>      | QUERY TRAN NAME( <i>traname</i> ) SHOW(ALL)  |
| Displays all of the transactions.  | /DISPLAY TRAN ALL                 | QUERY TRAN SHOW(ALL)                         |
| Displays all of the transactions on the shared queues with a global queue count. | /DISPLAY TRAN <i>traname</i> QCNT | QUERY TRAN NAME( <i>traname</i> ) SHOW(QCNT) |

Table 34. Type-2 equivalents for the /DISPLAY USER command

| <b>Task</b>                              | <b>/DISPLAY USER command</b>        | <b>Similar IMS type-2 command</b>                |
|--|-------------------------------------|--|
| Displays preset destination.             | /DISPLAY USER <i>user</i>           | QUERY USER SHOW(PRESET)                          |
| Displays node.                           | /DISPLAY USER <i>user</i>           | QUERY USER SHOW(NODE)<br>QUERY USERID SHOW(NODE) |
| Displays status for a particular user.   | /DISPLAY USER <i>user</i>           | QUERY USER SHOW(STATUS)                          |
| Displays user ID.                        | /DISPLAY USER <i>user</i>           | QUERY USER SHOW(USERID)                          |
| Displays status of a particular user ID. | /DISPLAY USER <i>user</i>           | QUERY USERID SHOW(STATUS)                        |
| Displays user.                           | /DISPLAY USER <i>user</i>           | QUERY USERID SHOW(USER)                          |
| Displays autologon parameters.           | /DISPLAY USER <i>user</i> AUTOLOGON | QUERY USER SHOW(AUTOLOGON)                       |

Table 34. Type-2 equivalents for the /DISPLAY USER command (continued)

| <b>Task</b>   | <b>/DISPLAY USER command</b>                                | <b>Similar IMS type-2 command</b> |
|---|---|-----------------------------------|
| Displays queue count.   | /DISPLAY USER <i>user</i><br>/DISPLAY USER <i>user</i> QCNT | QUERY USER SHOW(QCNT)             |
| Displays message queue count in the Expedited Message Handler (EMH) queues. | /DISPLAY USER <i>user</i> QCNT EMHQ                         | QUERY USER SHOW(EMHQ)             |
| Displays status recovery information.                                       | /DISPLAY USER <i>user</i> RECOVERY                          | QUERY USER SHOW(RECOVERY)         |
| Displays owner IMSID in RM resource structure.                              | /DISPLAY USER <i>user</i> RECOVERY                          | QUERY USER SHOW(OWNER)            |

Table 35. Type-2 equivalents for the /LOCK command

| <b>Task</b>                  | <b>/LOCK command</b>       | <b>Similar IMS type-2 command</b>                    |
|------------------------------|----------------------------|--|
| Stops the use of a database. | /LOCK DB <i>dbname</i>     | UPDATE DB NAME( <i>dbname</i> )<br>SET(LOCK(ON))     |
| Locks a program.             | /LOCK PGM <i>pgmname</i>   | UPDATE PGM NAME( <i>pgmname</i> )<br>SET(LOCK(ON))   |
| Locks a transaction.         | /LOCK TRAN <i>tranname</i> | UPDATE TRAN NAME( <i>tranname</i> )<br>SET(LOCK(ON)) |

Table 36. Type-2 equivalents for the /MSASSIGN command

| <b>Task</b>  | <b>/MSASSIGN command</b>                               | <b>Similar IMS type-2 command</b>                                 |
|--|--|---|
| Changes the transaction so that it is local and runs on the local system.                    | /MSASSIGN TRAN <i>tranname</i> TO LOCAL                | UPDATE TRAN NAME( <i>tranname</i> )<br>SET(REMOTE(N))             |
| Changes the transaction so that it is remote, and assign it to a specific logical link path. | /MSASSIGN TRAN <i>tranname</i> TO MSNAME <i>msname</i> | UPDATE TRAN NAME( <i>tranname</i> )<br>SET(MSNAME( <i>name</i> )) |

Table 37. Type-2 equivalents for the /PSTOP command

| <b>Task</b>  | <b>/PSTOP command</b>                   | <b>Similar IMS type-2 command</b>                              |
|--|---|--|
| Stops the scheduling of transactions.  | /PSTOP TRAN <i>tranname</i>             | UPDATE TRAN( <i>tranname</i> ) START(Q)<br>STOP(SCHD)          |
| Stops logons to the physical link (only for MSC VTAM links).   | /PSTOP MSPLINK <i>msplinkname</i>   ALL | UPDATE MSPLINK<br>NAME( <i>msplinkname</i>   *)<br>STOP(LOGON) |
| Posts the regions in which the program is scheduled so that a new refreshed copy of the program can be obtained on the next schedule of the program. | /PSTOP REGION TRAN <i>tranname</i>      | UPDATE PGM START(REFRESH)                                      |

Table 38. Type-2 equivalents for the /PURGE command

| Task  | /PURGE command              | Similar IMS type-2 command                                 |
|---|-----------------------------|--|
| Stops input messages for a particular transaction code. | /PURGE TRAN <i>tranname</i> | UPDATE TRAN NAME( <i>tranname</i> )<br>START(SCHD) STOP(Q) |

Table 39. Type-2 equivalents for the /RDISPLAY command

| Task  | /RDISPLAY command | Similar IMS type-2 command   |
|---|-------------------|------------------------------|
| Displays the primary and secondary master terminal. | /RDISPLAY MASTER  | QUERY LTERM STATUS(MTO,SMT0) |

Table 40. Type-2 equivalents for the /RSTART command

| Task  | /RSTART command                          | Similar IMS type-2 command                                      |
|---|--|---|
| Resets MSC TCP/IP or VTAM links to enable logons. | /RSTART MSPLINK <i>msplinkname</i>   ALL | UPDATE MSPLINK<br>NAME( <i>msplinkname</i>   *)<br>START(LOGON) |

Table 41. Type-2 equivalents for the /START AREA command

| Task             | /START AREA command         | Similar IMS type-2 command                           |
|------------------|-----------------------------|--|
| Starts the area. | /START AREA <i>areaname</i> | UPDATE AREA NAME( <i>areaname</i> )<br>START(ACCESS) |

Table 42. Type-2 equivalents for the /START DATAGRP command

| Task                   | /START DATAGRP command            | Similar IMS type-2 command                                    |
|------------------------|-----------------------------------|---|
| Starts the data group. | /START DATAGRP <i>datagrpname</i> | UPDATE DATAGRP<br>NAME( <i>datagrpname</i> )<br>START(ACCESS) |

Table 43. Type-2 equivalents for the /START DB command

| Task  | /START DB command       | Similar IMS type-2 command                       |
|---|-------------------------|--|
| Starts a database and change access intent of the database. | /START DB ACCESS        | UPDATE DB START(ACCESS)<br>SET(ACCTYPE())        |
| Starts a database.  | /START DB <i>dbname</i> | UPDATE DB NAME( <i>dbname</i> )<br>START(ACCESS) |

Table 44. Type-2 equivalents for the /START PGM command

| Task                       | /START PGM command        | Similar IMS type-2 command                       |
|----------------------------|---------------------------|--|
| Starts program scheduling. | /START PGM <i>pgmname</i> | UPDATE PGM NAME( <i>pgmname</i> )<br>START(SCHD) |

Table 45. Type-2 equivalents for the /START RTC command

| Task  | /START RTC command        | Similar IMS type-2 command                    |
|---|---------------------------|---|
| Starts queuing to a Fast Path routing code. | /START RTC <i>rtcname</i> | UPDATE RTC NAME( <i>rtcname</i> )<br>START(Q) |

Table 46. Type-2 equivalents for the /START TRAN command

| Task                  | /START TRAN command | Similar IMS type-2 command                                   |
|-----------------------|---------------------|--|
| Starts a transaction. | /START TRAN         | UPDATE TRAN NAME( <i>tranname</i> )<br>START(Q,SCHD,SUSPEND) |

Table 47. Type-2 equivalents for the /STOP AREA command

| Task           | /STOP AREA command         | Similar IMS type-2 command                        |
|----------------|----------------------------|---|
| Stops an area. | /STOP AREA <i>areaname</i> | UPDATE AREA NAME( <i>areaname</i> )<br>STOP(SCHD) |

Table 48. Type-2 equivalents for the /STOP DATAGRP command

| Task                | /STOP DATAGRP command            | Similar IMS type-2 command                              |
|---------------------|----------------------------------|---|
| Stops a data group. | /STOP DATAGRP <i>datagrpname</i> | UPDATE DATAGRP<br>NAME( <i>datagrpname</i> ) STOP(SCHD) |

Table 49. Type-2 equivalents for the /STOP DB command

| Task              | /STOP DB command       | Similar IMS type-2 command                    |
|-------------------|------------------------|---|
| Stops a database. | /STOP DB <i>dbname</i> | UPDATE DB NAME( <i>dbname</i> )<br>STOP(SCHD) |

Table 50. Type-2 equivalents for the /STOP PGM command

| Task                      | /STOP PGM command        | Similar IMS type-2 command                      |
|---------------------------|--------------------------|---|
| Stops program scheduling. | /STOP PGM <i>pgmname</i> | UPDATE PGM NAME( <i>pgmname</i> )<br>STOP(SCHD) |

Table 51. Type-2 equivalents for the /STOP RTC command

| Task                                       | /STOP RTC command        | Similar IMS type-2 command                   |
|--|--------------------------|--|
| Stops queuing to a Fast Path routing code. | /STOP RTC <i>rtcname</i> | UPDATE RTC NAME( <i>rtcname</i> )<br>STOP(Q) |

Table 52. Type-2 equivalents for the /STOP TRAN command

| Task   | /STOP TRAN command         | Similar IMS type-2 command                          |
|--|----------------------------|---|
| Stops the queuing and scheduling of messages destined for a transaction. | /STOP TRAN <i>tranname</i> | UPDATE TRAN NAME( <i>tranname</i> )<br>STOP(Q,SCHD) |

Table 53. Type-2 equivalents for the /TRACE PGM command

| Task                             | /TRACE PGM command                | Similar IMS type-2 command                        |
|----------------------------------|-----------------------------------|---|
| Starts the tracing of a program. | /TRACE SET ON PGM <i>pgmname</i>  | UPDATE PGM NAME( <i>pgmname</i> )<br>START(TRACE) |
| Stops the tracing of a program.  | /TRACE SET OFF PGM <i>pgmname</i> | UPDATE PGM NAME( <i>pgmname</i> )<br>STOP(TRACE)  |

Table 54. Type-2 equivalents for the /TRACE TRAN command

| Task                                 | /TRACE TRAN command                 | Similar IMS type-2 command                          |
|--------------------------------------|-------------------------------------|---|
| Starts the tracing of a transaction. | /TRACE SET ON TRAN <i>tranname</i>  | UPDATE TRAN NAME( <i>tranname</i> )<br>START(TRACE) |
| Stops the tracing of a transaction.  | /TRACE SET OFF TRAN <i>tranname</i> | UPDATE TRAN NAME( <i>tranname</i> )<br>STOP(TRACE)  |

Table 55. Type-2 equivalents for the /UNLOCK DB command

| Task                | /UNLOCK DB command       | Similar IMS type-2 command                        |
|---------------------|--------------------------|---|
| Unlocks a database. | /UNLOCK DB <i>dbname</i> | UPDATE DB NAME( <i>dbname</i> )<br>SET(LOCK(OFF)) |

Table 56. Type-2 equivalents for the /UNLOCK PGM command

| Task               | /UNLOCK PGM command        | Similar IMS type-2 command                          |
|--------------------|----------------------------|---|
| Unlocks a program. | /UNLOCK PGM <i>pgmname</i> | UPDATE PGM NAME( <i>pgmname</i> )<br>SET(LOCK(OFF)) |

Table 57. Type-2 equivalents for the /UNLOCK TRAN command

| Task                   | /UNLOCK TRAN command         | Similar IMS type-2 command                            |
|------------------------|------------------------------|---|
| Unlocks a transaction. | /UNLOCK TRAN <i>tranname</i> | UPDATE TRAN NAME( <i>tranname</i> )<br>SET(LOCK(OFF)) |

### Related concepts

[Commands for IMS operations tasks \(Operations and Automation\)](#)

## Equivalent IMS Connect WTOR, z/OS, and type-2 commands

Certain IMS Connect WTOR commands, IMS Connect z/OS commands, and IMS Connect type-2 commands perform similar tasks.

The following table shows the different instances of the IMS Connect WTOR, z/OS, and type-2 commands that perform similar tasks.

Table 58. WTOR and IMS Connect z/OS equivalents for the QUERY IMSCON TYPE(ALIAS) command

| QUERY IMSCON TYPE(ALIAS) command   | Equivalent IMS Connect WTOR command          | Equivalent IMS Connect z/OS command                                |
|--|--|--|
| QUERY IMSCON TYPE(ALIAS) NAME(*)<br>SHOW(ALL   <i>show_parm</i> )                      | VIEWIA ALL                                   | QUERY ALIAS NAME(*)  |
| QUERY IMSCON TYPE(ALIAS)<br>NAME( <i>alias_name</i> ) SHOW(ALL  <br><i>show_parm</i> ) | VIEWIA <i>alias_name</i>                     | QUERY ALIAS<br>NAME( <i>aliasName</i> )                            |
| QUERY IMSCON TYPE(ALIAS)<br>NAME( <i>alias_name</i> ) ODBM( <i>odbm_name</i> )         | VIEWIA <i>alias_name</i><br><i>odbm_name</i> | QUERY ALIAS<br>NAME( <i>aliasName</i> )<br>ODBM( <i>odbmName</i> ) |



Table 59. WTOR and IMS Connect z/OS equivalents for the QUERY IMSCON TYPE(CONFIG) command

| <b>QUERY IMSCON TYPE(CONFIG) command</b>                | <b>Equivalent IMS Connect WTOR command</b> | <b>Equivalent IMS Connect z/OS command</b> |
|---|--|--|
| QUERY IMSCON TYPE(CONFIG) SHOW(ALL   <i>show_parm</i> ) | VIEWHWS                                    | QUERY MEMBER TYPE(IMSCON) SHOW(ALL)        |

Table 60. WTOR and IMS Connect z/OS equivalents for the QUERY IMSCON TYPE(DATASTORE) command

| <b>QUERY IMSCON TYPE(DATASTORE) command</b>  | <b>Equivalent IMS Connect WTOR command</b> | <b>Equivalent IMS Connect z/OS command</b>    |
|--|--|---|
| QUERY IMSCON TYPE(DATASTORE) NAME(*) SHOW(ALL   <i>show_parm</i> )                       | VIEWDS ALL                                 | QUERY DATASTORE NAME(*) SHOW(ALL)             |
| QUERY IMSCON TYPE(DATASTORE) NAME( <i>datastore_name</i> ) SHOW(ALL   <i>show_parm</i> ) | VIEWDS <i>datastore_name</i>               | QUERY DATASTORE NAME( <i>datastore_name</i> ) |

Table 61. WTOR and IMS Connect z/OS equivalents for the QUERY IMSCON TYPE(IMSPLEX) command

| <b>QUERY IMSCON TYPE(IMSPLEX) command</b>  | <b>Equivalent IMS Connect WTOR command</b> | <b>Equivalent IMS Connect z/OS command</b>         |
|--|--|--|
| QUERY IMSCON TYPE(IMSPLEX) NAME(*) SHOW(ALL   <i>show_parm</i> )                     | VIEWIP ALL                                 | QUERY IMSPLEX NAME(*) SHOW(ALL)                    |
| QUERY IMSCON TYPE(IMSPLEX) NAME( <i>IMSplex_name</i> ) SHOW(ALL   <i>show_parm</i> ) | VIEWIP <i>IMSplex_name</i>                 | QUERY IMSPLEX NAME( <i>imsplexName</i> ) SHOW(ALL) |

Table 62. WTOR and IMS Connect z/OS equivalents for the QUERY IMSCON TYPE(MSC) command

| <b>QUERY IMSCON TYPE(MSC) command</b>                                      | <b>Equivalent IMS Connect WTOR command</b> | <b>Equivalent IMS Connect z/OS command</b> |
|--|--|--|
| QUERY IMSCON TYPE(MSC) NAME(*) SHOW(ALL   <i>show_parm</i> )               | VIEWMSC ALL                                | QUERY MSC NAME(*)                          |
| QUERY IMSCON TYPE(MSC) NAME( <i>msc_id</i> ) SHOW(ALL   <i>show_parm</i> ) | VIEWMSC <i>msc_id</i>                      | QUERY MSC NAME( <i>msc_id</i> )            |

Table 63. WTOR and IMS Connect z/OS equivalents for the QUERY IMSCON TYPE(PORT) command

| <b>QUERY IMSCON TYPE(PORT) command</b>                                      | <b>Equivalent IMS Connect WTOR command</b> | <b>Equivalent IMS Connect z/OS command</b>  |
|---|--|---|
| QUERY IMSCON TYPE(PORT) NAME(*) SHOW(ALL   <i>show_parm</i> )               | VIEWPORT ALL                               | QUERY PORT NAME(*) SHOW(ALL)                |
| QUERY IMSCON TYPE(PORT) NAME( <i>portid</i> ) SHOW(ALL   <i>show_parm</i> ) | VIEWPORT <i>port_id</i>                    | QUERY PORT NAME( <i>port_id</i> ) SHOW(ALL) |
| QUERY IMSCON TYPE(PORT) NAME(LOCAL) SHOW(ALL   <i>show_parm</i> )           | VIEWPORT LOCAL                             | QUERY PORT NAME(LOCAL) SHOW(ALL)            |

Table 64. WTOR and IMS Connect z/OS equivalents for the QUERY IMSCON TYPE(RMTIMSCON) command

| <b>QUERY IMSCON TYPE(RMTIMSCON) command</b>  | <b>Equivalent IMS Connect WTOR command</b> | <b>Equivalent IMS Connect z/OS command</b>    |
|--|--|---|
| QUERY IMSCON TYPE(RMTIMSCON) NAME(*) SHOW(ALL   <i>show_parm</i> )                       | VIEWRMT ALL                                | QUERY RMTIMSCON NAME(*)                       |
| QUERY IMSCON TYPE(RMTIMSCON) NAME( <i>rmtimscon_name</i> ) SHOW(ALL   <i>show_parm</i> ) | VIEWRMT <i>rmtimscon_name</i>              | QUERY RMTIMSCON NAME( <i>rmtimscon_name</i> ) |

Table 65. WTOR and IMS Connect z/OS equivalents for the QUERY IMSCON TYPE(UOR) command

| <b>QUERY IMSCON TYPE(UOR) command</b>                                      | <b>Equivalent IMS Connect WTOR command</b> | <b>Equivalent IMS Connect z/OS command</b> |
|--|--|--|
| QUERY IMSCON TYPE(UOR) NAME(*) SHOW(ALL   <i>show_parm</i> )               | VIEWUOR ALL                                | QUERY UOR NAME(*) SHOW(ALL)                |
| QUERY IMSCON TYPE(UOR) NAME( <i>uor_id</i> ) SHOW(ALL   <i>show_parm</i> ) | VIEWUOR <i>uor_id</i>                      | QUERY UOR NAME( <i>uor_id</i> ) SHOW(ALL)  |
| QUERY IMSCON TYPE(UOR) STATE( <i>state</i> )                               | None                                       | None                                       |

Table 66. WTOR and IMS Connect z/OS equivalents for the UPDATE IMSCON TYPE(ALIAS) command

| <b>UPDATE IMSCON TYPE(ALIAS) command</b>   | <b>Equivalent IMS Connect WTOR command</b> | <b>Equivalent IMS Connect z/OS command</b>                                 |
|--|--|--|
| UPDATE IMSCON TYPE(ALIAS) NAME( <i>alias_name</i> ) ODBM( <i>odbm_name</i> ) START(COMM) | STARTIA <i>alias_name</i> <i>odbm_name</i> | UPDATE ALIAS NAME( <i>aliasName</i> ) ODBM( <i>odbmName</i> ) START(ROUTE) |
| UPDATE IMSCON TYPE(ALIAS) NAME( <i>alias_name</i> ) ODBM( <i>odbm_name</i> ) STOP(COMM)  | STOPIA <i>alias_name</i> <i>odbm_name</i>  | UPDATE ALIAS NAME( <i>aliasName</i> ) ODBM( <i>odbmName</i> ) STOP(ROUTE)  |

Table 67. WTOR and IMS Connect z/OS equivalents for the UPDATE IMSCON TYPE(CLIENT) command

| <b>UPDATE IMSCON TYPE(CLIENT) command</b>  | <b>Equivalent IMS Connect WTOR command</b> | <b>Equivalent IMS Connect z/OS command</b>                      |
|--|--|---|
| UPDATE IMSCON TYPE(CLIENT) NAME( <i>client_name</i> ) PORT( <i>portid</i> ) STOP(COMM) | STOPCLNT <i>portid</i> <i>clientid</i>     | DELETE PORT NAME( <i>portName</i> ) CLIENT( <i>clientName</i> ) |

Table 68. WTOR and IMS Connect z/OS equivalents for the UPDATE IMSCON TYPE(CONFIG) command

| <b>UPDATE IMSCON TYPE(CONFIG) command</b>                 | <b>Equivalent IMS Connect WTOR command</b> | <b>Equivalent IMS Connect z/OS command</b> |
|---|--|--|
| UPDATE IMSCON TYPE(CONFIG) SHUTDOWN(COMM)                 | CLOSEHWS                                   | SHUTDOWN MEMBER                            |
| UPDATE IMSCON TYPE(CONFIG) SHUTDOWN(COMM) OPTION(FORCE)   | CLOSEHWS FORCE                             | SHUTDOWN MEMBER OPTION(FORCE)              |
| UPDATE IMSCON TYPE(CONFIG) SHUTDOWN(COMM) OPTION(QUIESCE) | CLOSEHWS QUIESCE                           | SHUTDOWN MEMBER OPTION(QUIESCE)            |

Table 68. WTOR and IMS Connect z/OS equivalents for the UPDATE IMSCON TYPE(CONFIG) command (continued)

| <b>UPDATE IMSCON TYPE(CONFIG) command</b>        | <b>Equivalent IMS Connect WTOR command</b> | <b>Equivalent IMS Connect z/OS command</b>          |
|--|--|---|
| UPDATE IMSCON TYPE(CONFIG)<br>SET(OAUTO(ON))     | SETOAUTO YES                               | UPDATE MEMBER<br>TYPE(IMSCON)<br>SET(OAUTO(ON))     |
| UPDATE IMSCON TYPE(CONFIG)<br>SET(OAUTO(OFF))    | SETOAUTO NO                                | UPDATE MEMBER<br>TYPE(IMSCON)<br>SET(OAUTO(OFF))    |
| UPDATE IMSCON TYPE(CONFIG)<br>SET(PSWDMC(ON))    | SETPWMC ON                                 | UPDATE MEMBER<br>TYPE(IMSCON)<br>SET(PSWDMC(ON))    |
| UPDATE IMSCON TYPE(CONFIG)<br>SET(PSWDMC(OFF))   | SETPWMC OFF                                | UPDATE MEMBER<br>TYPE(IMSCON)<br>SET(PSWDMC(OFF))   |
| UPDATE IMSCON TYPE(CONFIG)<br>SET(PSWDMC(RCF))   | SETPWMC RCF                                | UPDATE MEMBER<br>TYPE(IMSCON)<br>SET(PSWDMC(RCF))   |
| UPDATE IMSCON TYPE(CONFIG)<br>SET(RACF(ON))      | SETRACF ON                                 | UPDATE MEMBER<br>TYPE(IMSCON)<br>SET(RACF(ON))      |
| UPDATE IMSCON TYPE(CONFIG)<br>SET(RACF(OFF))     | SETRACF OFF                                | UPDATE MEMBER<br>TYPE(IMSCON)<br>SET(RACF(OFF))     |
| UPDATE IMSCON TYPE(CONFIG)<br>SET(RRS(ON))       | SETRRS ON                                  | UPDATE MEMBER<br>TYPE(IMSCON)<br>SET(RRS(ON))       |
| UPDATE IMSCON TYPE(CONFIG)<br>SET(RRS(OFF))      | SETRRS OFF                                 | UPDATE MEMBER<br>TYPE(IMSCON)<br>SET(RRS(OFF))      |
| UPDATE IMSCON TYPE(CONFIG)<br>SET(UIDCACHE(ON))  | SETUIDC ON                                 | UPDATE MEMBER<br>TYPE(IMSCON)<br>SET(UIDCACHE(ON))  |
| UPDATE IMSCON TYPE(CONFIG)<br>SET(UIDCACHE(OFF)) | SETUIDC OFF                                | UPDATE MEMBER<br>TYPE(IMSCON)<br>SET(UIDCACHE(OFF)) |
| UPDATE IMSCON TYPE(CONFIG)<br>START(RECORDER)    | RECORDER OPEN                              | UPDATE MEMBER<br>TYPE(IMSCON)<br>START(TRACE)       |
| UPDATE IMSCON TYPE(CONFIG)<br>STOP(RECORDER)     | RECORDER CLOSE                             | UPDATE MEMBER<br>TYPE(IMSCON)<br>STOP(TRACE)        |

Table 69. WTOR and IMS Connect z/OS equivalents for the UPDATE IMSCON TYPE(CONVERTER) command

| <b>UPDATE IMSCON TYPE(CONVERTER) command</b>                                   | <b>Equivalent IMS Connect WTOR command</b>         | <b>Equivalent IMS Connect z/OS command</b>                           |
|--|--|--|
| UPDATE IMSCON TYPE(CONVERTER)<br>NAME( <i>converter_name</i> ) OPTION(REFRESH) | REFRESH CONVERTER<br>NAME( <i>converter_name</i> ) | UPDATE CONVERTER<br>NAME( <i>converter_name</i> )<br>OPTION(REFRESH) |

Table 70. WTOR and IMS Connect z/OS equivalents for the UPDATE IMSCON TYPE(DATASTORE) command

| <b>UPDATE IMSCON TYPE(DATASTORE) command</b>                               | <b>Equivalent IMS Connect WTOR command</b>                | <b>Equivalent IMS Connect z/OS command</b>                      |
|--|---|---|
| UPDATE IMSCON TYPE(DATASTORE)<br>NAME( <i>datastore_name</i> ) START(COMM) | OPENDS <i>datastore_id</i><br>STARTDS <i>datastore_id</i> | UPDATE DATASTORE<br>NAME( <i>datastoreName</i> )<br>START(COMM) |
| UPDATE IMSCON TYPE(DATASTORE)<br>NAME( <i>datastore_name</i> ) STOP(COMM)  | STOPDS <i>datastore_id</i>                                | UPDATE DATASTORE<br>NAME( <i>datastoreName</i> )<br>STOP(COMM)  |
| UPDATE IMSCON TYPE(DATASTORE)<br>NAME( <i>datastore_name</i> ) SET()       | None  | None  |

Table 71. WTOR and IMS Connect z/OS equivalents for the UPDATE IMSCON TYPE(IMSPLEX) command

| <b>UPDATE IMSCON TYPE(IMSPLEX) command</b>                             | <b>Equivalent IMS Connect WTOR command</b>            | <b>Equivalent IMS Connect z/OS command</b>                   |
|--|---|--|
| UPDATE IMSCON TYPE(IMSPLEX)<br>NAME( <i>imsplex_name</i> ) START(COMM) | OPENIP <i>imsplex_id</i><br>STARTIP <i>imsplex_id</i> | UPDATE IMSPLEX<br>NAME( <i>imsplex_name</i> )<br>START(COMM) |
| UPDATE IMSCON TYPE(IMSPLEX)<br>NAME( <i>imsplex_name</i> ) STOP(COMM)  | STOPIP <i>imsplex_id</i>                              | UPDATE IMSPLEX<br>NAME( <i>imsplex_name</i> )<br>STOP(COMM)  |

Table 72. WTOR and IMS Connect z/OS equivalents for the UPDATE IMSCON TYPE(LINK) command

| <b>UPDATE IMSCON TYPE(LINK) command</b>  | <b>Equivalent IMS Connect WTOR command</b>     | <b>Equivalent IMS Connect z/OS command</b>                            |
|--|--|---|
| UPDATE IMSCON TYPE(LINK)<br>NAME( <i>logical_link_name</i> ) STOP(COMM)                            | STOPLINK<br><i>logical_link_name</i>           | DELETE LINK<br>NAME( <i>linkName</i> )                                |
| UPDATE IMSCON TYPE(LINK)<br>NAME( <i>logical_link_name</i> ) MSC( <i>lclplk_id</i> )<br>STOP(COMM) | STOPLINK<br><i>logical_link_name lclplk_id</i> | DELETE LINK<br>NAME( <i>linkname</i> )<br>LCLPLKID( <i>lclPlkid</i> ) |

Table 73. WTOR and IMS Connect z/OS equivalents for the UPDATE IMSCON TYPE(MSC) command

| <b>UPDATE IMSCON TYPE(MSC) command</b>                         | <b>Equivalent IMS Connect WTOR command</b> | <b>Equivalent IMS Connect z/OS command</b>        |
|--|--|---|
| UPDATE IMSCON TYPE(MSC)<br>NAME( <i>lclPlkid</i> ) START(COMM) | STARTMSC <i>lclPlkid</i>                   | UPDATE MSC NAME( <i>lclPlkid</i> )<br>START(COMM) |
| UPDATE IMSCON TYPE(MSC)<br>NAME( <i>lclPlkid</i> ) STOP(COMM)  | STOPMSC <i>lclPlkid</i>                    | UPDATE MSC NAME( <i>lclPlkid</i> )<br>STOP(COMM)  |

Table 74. WTOR and IMS Connect z/OS equivalents for the UPDATE IMSCON TYPE(ODBM) command

| <b>UPDATE IMSCON TYPE(ODBM) command</b>                          | <b>Equivalent IMS Connect WTOR command</b> | <b>Equivalent IMS Connect z/OS command</b>            |
|--|--|---|
| UDPATE IMSCON TYPE(ODBM)<br>NAME( <i>odbm_name</i> ) START(COMM) | STARTOD <i>odbm_name</i>                   | UPDATE ODBM<br>NAME( <i>odbmName</i> )<br>START(COMM) |
| UDPATE IMSCON TYPE(ODBM)<br>NAME( <i>odbm_name</i> ) STOP(COMM)  | STOPOD <i>odbm_name</i>                    | UPDATE ODBM<br>NAME( <i>odbmName</i> )<br>STOP(COMM)  |

Table 75. WTOR and IMS Connect z/OS equivalents for the UPDATE IMSCON TYPE(PORT) command

| <b>UPDATE IMSCON TYPE(PORT) command</b>                          | <b>Equivalent IMS Connect WTOR command</b>        | <b>Equivalent IMS Connect z/OS command</b>             |
|--|---|--|
| UDPATE IMSCON TYPE(PORT)<br>NAME( <i>port_name</i> ) START(COMM) | OPENPORT <i>port_id</i><br>STARTPT <i>port_id</i> | UPDATE PORT<br>NAME( <i>port_name</i> )<br>START(COMM) |
| UDPATE IMSCON TYPE(PORT)<br>NAME( <i>port_name</i> ) STOP(COMM)  | STOPPORT <i>port_id</i>                           | UPDATE PORT<br>NAME( <i>port_name</i> )<br>STOP(COMM)  |

Table 76. WTOR and IMS Connect z/OS equivalents for the UPDATE IMSCON TYPE(RACFUID) command

| <b>UPDATE IMSCON TYPE(RACFUID) command</b>                           | <b>Equivalent IMS Connect WTOR command</b> | <b>Equivalent IMS Connect z/OS command</b>                 |
|--|--|--|
| UPDATE IMSCON TYPE(RACFUID)<br>NAME( <i>userid</i> ) OPTION(REFRESH) | REFRESH RACFUID<br>NAME( <i>userid</i> )   | UPDATE RACFUID<br>NAME( <i>userid</i> )<br>OPTION(REFRESH) |

Table 77. WTOR and IMS Connect z/OS equivalents for the UPDATE IMSCON TYPE(RMTIMSCON) command

| <b>UPDATE IMSCON TYPE(RMTIMSCON) command</b>                               | <b>Equivalent IMS Connect WTOR command</b> | <b>Equivalent IMS Connect z/OS command</b>                      |
|--|--|---|
| UPDATE IMSCON TYPE(RMTIMSCON)<br>NAME( <i>rmtimscon_name</i> ) START(COMM) | STARTRMT <i>rmtimsconName</i>              | UPDATE RMTIMSCON<br>NAME( <i>rmtimsconName</i> )<br>START(COMM) |
| UPDATE IMSCON TYPE(RMTIMSCON)<br>NAME( <i>rmtimscon_name</i> ) STOP(COMM)  | STOPRMT <i>rmtimsconName</i>               | UPDATE RMTIMSCON<br>NAME( <i>rmtimsconName</i> )<br>STOP(COMM)  |

Table 78. WTOR and MS Connect z/OS equivalents for the UPDATE IMSCON TYPE(SENDCLNT) command

| <b>UPDATE IMSCON TYPE(SENDCLNT) command</b>  | <b>Equivalent IMS Connect WTOR command</b>     | <b>Equivalent IMS Connect z/OS command</b>                                      |
|--|--|---|
| UPDATE IMSCON<br>TYPE(SENDCLNT) NAME( <i>sendclient_name</i> )<br>RMTIMSCON( <i>rmtimscon_name</i> )<br>STOP(COMM) | STOPSCLN <i>rmtimscon</i><br><i>sendclient</i> | DELETE RMTIMSCON<br>NAME( <i>rmtimsconname</i> )<br>SENDCLNT( <i>clientid</i> ) |

Table 78. WTOR and MS Connect z/OS equivalents for the UPDATE IMSCON TYPE(SENDCLNT) command (continued)

| <b>UPDATE IMSCON TYPE(SENDCLNT) command</b>   | <b>Equivalent IMS Connect WTOR command</b>   | <b>Equivalent IMS Connect z/OS command</b> |
|---|--|--|
| UPDATE IMSCON<br>TYPE(SENDCLNT) NAME( <i>sendclient_name</i> )<br>RMTICIS( <i>rmtcics_name</i> ) STOP(COMM) | STOPSCLN <i>rmtcics</i><br><i>sendclient</i> | No equivalent z/OS command                 |

## Chapter 2. Command keywords and their synonyms

All IMS command keywords and their synonyms, as well as keywords supported by the OM API, are listed. The list covers command keywords for the OM command processing clients such as IMS, ODBM, IMSCON, and RM.

IMS ignores misspelled keywords, and issues an error message when it encounters an invalid keyword. In an IMSplex, invalid or misspelled keywords will result in an UNKNOWN POSITIONAL PARAMETER message.

You can modify type-1 command keywords by using the IMS Command Language Modification Facility (DFSCWD0) with the KEYWD macro.

You can specify ALL=NO or ALL=DIS on the KEYWD macro to prevent the use of the ALL parameter.

- You can specify ALL=NO for all the type-1 command keywords that support the ALL parameter. ALL=NO indicates that the ALL parameter is invalid on all the IMS commands that apply to the keyword being changed.
- You can specify ALL=DIS for all the type-1 **/DISPLAY** command keywords that support the ALL parameter. ALL=DIS indicates that the ALL parameter is invalid on all the **/DISPLAY** commands that apply to the keyword being changed.

You can prevent the use of the NAME(\*) parameter on type-2 commands by using the CSL OM input user exit routine.

In the following table, the IMS keyword column is for the OM command processing clients such as IMS, ODBM, IMSCON, and RM. A keyword listed in the OM keyword column indicates that it is the only accepted form supported by the OM API. If no keyword is listed in the OM keyword column, then the IMS keyword or its synonym is acceptable. If no synonyms are listed, none are permitted.

Table 79. Command keywords and their synonyms

| IMS keyword | Synonym    | OM keyword | Commands that support this keyword |
|-------------|------------|------------|------------------------------------|
| ABDUMP      |            |            | /CHECKPOINT<br>/STOP<br>/SWITCH    |
| ABORT       |            |            | /MODIFY                            |
| ACBLIB      |            |            | INITIATE OLC                       |
| ACCESS      |            |            | /START                             |
| ACTIVE      | A, ACT     | ACT        | /BROADCAST<br>/DISPLAY<br>/SWITCH  |
| ADAPTER     |            |            | QUERY OTMADESC                     |
| ADD         |            |            | /RECOVER                           |
| ADDRESS     |            |            | /DIAGNOSE                          |
| ADS         |            |            | /STOP                              |
| AFFINITY    | AFFIN, AFF | AFFIN      | /DISPLAY<br>/START                 |

Table 79. Command keywords and their synonyms (continued)

| IMS keyword | Synonym                 | OM keyword | Commands that support this keyword  |
|-------------|-------------------------|------------|---|
| ALIAS       |                         |            | QUERY ODBM<br>UPDATE ODBM   |
| ALLENTRIES  | ALLENT                  |            | /RECOVER  |
| AOITOKEN    | AOITKN                  | AOITKN     | /DEQUEUE<br>/DISPLAY<br>/PSTOP  |
| APDB        |                         |            | /TRACE MONITOR  |
| APMQ        |                         |            | /TRACE MONITOR  |
| APPC        |                         |            | /DISPLAY<br>/PURGE<br>/SECURE<br>/START<br>/STOP                                |
| AREA        |                         |            | /DBRECOVERY<br>/DIAGNOSE<br>/DISPLAY<br>/RECOVER<br>/START<br>/STOP<br>/VUNLOAD |
| ASR         |                         |            | QUERY MSLINK  |
| ASSIGNMENT  | ASMT                    | ASMT       | /DISPLAY  |
| ATTRIB      |                         |            | QUERY MEMBER  |
| AUTO        |                         |            | /TRACE  |
| AUTOARCH    | ARCHIVE,<br>AUTOARC     | AUTOARCH   | /START<br>/STOP   |
| AUTOLOGON   | AUTLGN                  |            | /DISPLAY  |
| BACKUP      | BU                      | BACKUP     | /ERESTART<br>/STOP<br>/SWITCH   |
| BALGRP      | BALG                    |            | /DISPLAY  |
| BANDWIDTH   |                         |            | QUERY MSLINK  |
| BKERR       |                         |            | /DISPLAY  |
| BLDL        |                         |            | INITIATE OLC  |
| BLOCK       |                         |            | /DIAGNOSE   |
| BUILDQ      | BLDQ, BLDQS,<br>BUILDQS |            | /ERESTART<br>/NRESTART  |



Table 79. Command keywords and their synonyms (continued)

| <b>IMS keyword</b> | <b>Synonym</b>              | <b>OM keyword</b> | <b>Commands that support this keyword</b>   |
|--------------------|-----------------------------|-------------------|---|
| CAGROUP            | CAGRP                       |                   | /RECOVER  |
| CANCEL             |                             |                   | /STOP   |
| CCTL               | CC                          | CCTL              | /DISPLAY  |
| CHECKPOINT         | CHECKPT,<br>CHKPOINT, CHKPT | CHKPT             | /ERESTART<br>/NRESTART<br>/SWITCH   |
| CLASS              | CLS                         | CLASS             | /ASSIGN<br>CREATE TRAN<br>CREATE TRANDESC<br>/DISPLAY<br>/PSTOP<br>/PURGE<br>QUERY TRAN<br>/START<br>/STOP<br>UPDATE TRAN |
| CMDAUTH            |                             |                   | /ERESTART<br>/NRESTART  |
| CMDAUTHE           |                             |                   | /ERESTART<br>/NRESTART  |
| CMTMODE            |                             |                   | CREATE TRAN<br>CREATE TRANDESC<br>QUERY OTMATI  |
| CNS                |                             |                   | /COMPT<br>/RCOMPT   |
| COLDBASE           | COLDB                       | COLDBASE          | /ERESTART   |
| COLDCOMM           | COLDC                       | COLDCOMM          | /ERESTART   |
| COLDSESS           |                             |                   | /CHANGE NODE<br>UPDATE MSLINK   |
| COLDSYS            | COLDS                       | COLDSYS           | /ERESTART   |
| COMMIT             |                             |                   | /MODIFY   |
| COMP               |                             |                   | /TRACE  |
| COMPONENT          | COMPT                       |                   | /ASSIGN   |
| CONTINUOUS         | CONT                        |                   | /RSTART   |

Table 79. Command keywords and their synonyms (continued)

| <b>IMS keyword</b> | <b>Synonym</b>        | <b>OM keyword</b> | <b>Commands that support this keyword</b>  |
|--------------------|-----------------------|-------------------|--|
| CONVERSATION       | CONV                  | CONV              | CREATE TRAN<br>CREATE TRANDESC<br>/DISPLAY<br>/EXIT<br>/RELEASE<br>/SET                            |
| CONVRTR            |                       |                   | QUERY OTMADESC   |
| CPLOG              |                       |                   | /CHANGE<br>/DISPLAY  |
| CPRI               |                       |                   | /ASSIGN  |
| CQS                |                       |                   | /DISPLAY   |
| CRD                |                       |                   | /COMPT   |
| DATA               |                       |                   | QUEUE LTERM<br>QUEUE TRAN  |
| DATABASE           | DATABASES, DB,<br>DBS | DB                | /DBDUMP<br>/DBRECOVERY<br>/DIAGNOSE<br>/DISPLAY<br>/LOCK<br>/RECOVER<br>/START<br>/STOP<br>/UNLOCK |
| DATAGROUP          | DATAGRP               | DATAGRP           | /DBRECOVERY<br>/START<br>/STOP<br>UPDATE   |
| DATASTORE          |                       |                   | QUERY ODBM<br>UPDATE ODBM  |
| DBALLOC            |                       |                   | /START   |
| DBD                |                       |                   | /DISPLAY   |
| DBDS               |                       |                   | /RECOVER   |
| DBDSGRP            |                       |                   | /RECOVER   |
| DBS                |                       |                   | /DISPLAY MODIFY  |
| DC                 |                       |                   | /DISPLAY<br>/START<br>/STOP  |

Table 79. Command keywords and their synonyms (continued)

| IMS keyword | Synonym       | OM keyword | Commands that support this keyword  |
|-------------|---------------|------------|---|
| DCLWA       |               |            | CREATE TRAN<br>CREATE TRANDESC  |
| DEFAULT     |               |            | CREATE DBDESC<br>CREATE PGMDESC<br>CREATE TRANDESC<br>QUERY DBDESC<br>QUERY PGMDESC<br>QUERY RTCDESC<br>QUERY TRANDESC<br>UPDATE DBDESC |
| DEFN        |               |            | DELETE<br>EXPORT<br>IMPORT  |
| DESCRIPTOR  | DESC, L62DESC | DESC       | /CHANGE<br>/DELETE<br>/DISPLAY<br>/START<br>/STOP   |
| DIRECTORY   | DIR           | DIR        | /CHANGE   |
| DIRROUTE    |               |            | CREATE TRAN<br>CREATE TRANDESC  |
| DOPT        |               |            | CREATE PGM<br>CREATE PGMDESC  |
| DUMPQ       | DUMPQS        | DUMPQ      | /CHECKPOINT<br>/RTAKEOVER   |
| EDITRTN     |               |            | CREATE TRAN<br>CREATE TRANDESC  |
| EDITUC      |               |            | CREATE TRAN<br>CREATE TRANDESC  |
| EMHBSZ      |               |            | CREATE TRAN<br>CREATE TRANDESC  |
| EMHQ        |               |            | /DISPLAY  |
| ENDTIME     |               |            | EXPORT  |
| ERRORABORT  |               |            | /RECOVER  |
| ERRORCONT   |               |            | /RECOVER  |

Table 79. Command keywords and their synonyms (continued)

| IMS keyword | Synonym    | OM keyword | Commands that support this keyword                             |
|-------------|------------|------------|--|
| EXIT        |            |            | /DISPLAY<br>/TRACE   |
| FDR         |            |            | /CHANGE<br>/DISPLAY  |
| FMTLIB      |            |            | INITIATE OLC   |
| FORCE       |            |            | /CLSDST<br>/PSTOP<br>/SWITCH                                   |
| FORCSESS    | FORC       |            | /CHANGE  |
| FORMAT      | FMT        |            | /ERESTART<br>/NRESTART   |
| FP          |            |            | CREATE PGM<br>CREATE PGMDESC<br>CREATE TRAN<br>CREATE TRANDESC |
| FPPROG      |            |            | /PURGE   |
| FPREGION    | FPRGN      | FPRGN      | /PURGE   |
| FPVIRTUAL   | FPV        | FPV        | /DISPLAY   |
| FRCABND     |            |            | INITIATE OLC   |
| FRCNRML     |            |            | INITIATE OLC   |
| FREEZE      |            |            | /CHECKPOINT<br>/RTAKEOVER                                      |
| GLOBAL      |            |            | /DBDUMP<br>/DBRECOVERY<br>QUERY TRAN<br>/START<br>/STOP        |
| GPSB        |            |            | CREATE PGM<br>CREATE PGMDESC                                   |
| GRPNAME     |            |            | QUERY OTMATI   |
| GRSNAME     | GRSN, GRS  |            | /START   |
| HSB         | HOTSTANDBY | HSB        | /DISPLAY   |
| HSSP        |            |            | /DISPLAY   |
| ICOMPONENT  | ICOMPT     |            | /ASSIGN  |

Table 79. Command keywords and their synonyms (continued)

| <b>IMS keyword</b> | <b>Synonym</b> | <b>OM keyword</b> | <b>Commands that support this keyword</b>                      |
|--------------------|----------------|-------------------|--|
| ID                 |                |                   | /CHANGE<br>/OPNDST   |
| IMSCON             |                | IMSCON            | CREATE<br>QUERY<br>UPDATE                                      |
| INDOUBT            | IND            |                   | /DISPLAY   |
| INPUT              |                |                   | /ASSIGN<br>/DISPLAY<br>/START<br>/STOP<br>/TRACE               |
| INQ                |                |                   | CREATE RTC<br>CREATE RTCDESC<br>CREATE TRAN<br>CREATE TRANDESC |
| INTERVAL           | INT, INTV      |                   | /CHANGE<br>/TRACE MONITOR                                      |
| JOBNAME            | JBN, JOBN      |                   | /PSTOP<br>/START<br>/STOP                                      |
| LA                 |                |                   | /TRACE MONITOR   |
| LANG               |                |                   | CREATE PGM<br>CREATE PGMDESC                                   |
| LCT                |                |                   | CREATE TRAN<br>CREATE TRANDESC                                 |
| LE                 |                |                   | DELETE<br>UPDATE<br>QUERY                                      |
| LEAVEGR            |                |                   | /CHECKPOINT  |
| LEAVEPLEX          |                |                   | /CHECKPOINT  |
| LEVEL              |                |                   | /TRACE   |
| LIBRARY            |                |                   | QUERY OLC  |

Table 79. Command keywords and their synonyms (continued)

| IMS keyword | Synonym | OM keyword | Commands that support this keyword   |
|-------------|---------|------------|--|
| LIKE        |         |            | CREATE DB<br>CREATE DBDESC<br>CREATE IMSCON<br>CREATE PGM<br>CREATE PGMDESC<br>CREATE TRAN<br>CREATE TRANDESC  |
| LINE        | LINES   | LINE       | /ASSIGN<br>/BROADCAST<br>/DEQUEUE<br>/DIAGNOSE<br>/DISPLAY<br>/END<br>/EXCLUSIVE<br>/EXIT<br>/IDLE<br>/LOOPTEST<br>/MONITOR<br>/PSTOP<br>/PURGE<br>/RSTART<br>/START<br>/STOP<br>/TEST<br>/TRACE |
| LINK        |         |            | /ACTIVATE<br>/CHANGE<br>/DIAGNOSE<br>/DISPLAY<br>/IDLE<br>/MSASSIGN<br>/PSTOP<br>/RSTART<br>/TRACE   |
| LMCT        | LCT     | LCT        | /ASSIGN  |
| LOCAL       |         |            | /DBDUMP<br>/DBRECOVERY<br>/MSASSIGN<br>/START<br>/STOP   |
| LOGOND      | LGND    |            | /CHANGE<br>/OPNDST   |
| LOPEN       |         |            | /RSTART  |

Table 79. Command keywords and their synonyms (continued)

| IMS keyword | Synonym | OM keyword | Commands that support this keyword   |
|-------------|---------|------------|--|
| LPRI        |         |            | /ASSIGN<br>CREATE TRAN<br>CREATE TRANDESC  |
| LTERM       | LTERMS  | LTERM      | /ASSIGN<br>/BROADCAST<br>DELETE LE<br>/DEQUEUE<br>/DIAGNOSE<br>/DISPLAY<br>/FORMAT<br>/LOCK<br>/MODIFY<br>/PSTOP<br>/PURGE<br>QUERY LE<br>QUERY OTMATI<br>/RMxxxxxx<br>/SET<br>/START<br>/STOP<br>/UNLOCK<br>UPDATE LE |
| LUNAME      | LU, LUN | LU         | /ALLOCATE<br>/CHANGE<br>/DEQUEUE<br>/DISPLAY<br>/EXIT<br>/START<br>/STOP<br>/TRACE   |
| MADSIOT     |         |            | /START<br>/STOP  |
| MASTER      |         |            | /BROADCAST<br>/DISPLAY<br>/RDISPLAY<br>/SMCOPY   |
| MAXRGN      |         |            | /CHANGE<br>CREATE TRAN<br>CREATE TRANDESC  |
| MEMBER      |         |            | UPDATE ODBM  |
| MODBLKS     |         |            | INITIATE OLC   |

Table 79. Command keywords and their synonyms (continued)

| IMS keyword | Synonym               | OM keyword | Commands that support this keyword   |
|-------------|-----------------------|------------|--|
| MODE        | MODETABLE,<br>MODETBL |            | /ALLOCATE<br>/CHANGE<br>/DISPLAY<br>/OPNDST  |
| MODIFY      |                       |            | /DISPLAY   |
| MODNAME     |                       |            | QUERY OTMATI   |
| MODULE      |                       |            | /DIAGNOSE<br>/TRACE  |
| MONITOR     | MON                   |            | /DISPLAY<br>/TRACE   |
| MSDBLOAD    |                       |            | /NRESTART  |
| MSG         | MESSAGE               |            | /SMCOPY<br>/TRACE  |
| MSGAGE      |                       |            | /DISPLAY<br>QUERY LTERM<br>QUERY OTMATI  |
| MSGTYPE     |                       |            | CREATE   |
| MSLINK      |                       |            | QUERY<br>UPDATE  |
| MSNAME      |                       |            | /BROADCAST<br>CREATE TRAN<br>CREATE TRANDESC<br>/DEQUEUE<br>/DIAGNOSE<br>/DISPLAY<br>/MSASSIGN<br>/MSVERIFY<br>/PURGE<br>/START<br>/STOP |
| MSPLINK     |                       |            | /DISPLAY<br>/MSASSIGN<br>/PSTOP  |
| MULTSIGN    |                       |            | /ERESTART<br>/NRESTART   |



Table 79. Command keywords and their synonyms (continued)

| IMS keyword | Synonym       | OM keyword | Commands that support this keyword   |
|-------------|---------------|------------|--|
| NAME        |               |            | CREATE DB, CREATE DBDESC,<br>CREATE IMSCON<br>CREATE OTMADESC,<br>CREATE PGM, CREATE PGMDESC,<br>CREATE RTC, CREATE RTCDESC,<br>DELETE DB, DELETE DBDESC,<br>DELETE OTMADESC,<br>DELETE PGM, DELETE PGMDESC,<br>DELETE RTC, DELETE RTCDESC,<br>DELETE TRAN, DELETE TRANDESC,<br>EXPORT, IMPORT<br>INITIATE OLREORG, QUERY AREA,<br>QUERY DB, QUERY DBDESC,<br>QUERY IMSCON, QUERY IMSPLEX,<br>QUERY LTERM, QUERY MSLINK,<br>QUERY MSNAME, QUERY MSPLINK,<br>QUERY NODE, QUERY ODBM,<br>QUERY OTMADESC,<br>QUERY PGM, QUERY PGMDESC,<br>QUERY OLREORG, QUERY RTC,<br>QUERY RTCDESC,<br>QUERY STRUCTURE, QUERY TRAN,<br>QUERY TRANDESC,<br>QUERY USER, QUERY USERID,<br>QUEUE LTERM,<br>QUEUE TRAN,<br>TERMINATE OLREORG,<br>UPDATE AREA, UPDATE DATAGRP,<br>UPDATE DB, UPDATE DBDESC,<br>UPDATE IMSCON, UPDATE MSLINK,<br>UPDATE MSNAME,<br>UPDATE MSPLINK,<br>UPDATE OLREORG, UPDATE OTMADESC,<br>UPDATE PGM, UPDATE PGMDESC,<br>UPDATE RTC, UPDATE RTCDESC,<br>UPDATE TRAN, UPDATE TRANDESC |
| NOBACKOUT   | NOBKO         |            | /START   |
| NOBMP       |               |            | /ERESTART  |
| NOBUILDQ    | NBLDQ, NOBLDQ |            | /NRESTART  |
| NOCHECK     |               |            | /RECOVER   |
| NOCMDAUTH   |               |            | /ERESTART<br>/NRESTART   |
| NOCMDAUTHE  |               |            | /ERESTART<br>/NRESTART   |
| NOCOMP      |               |            | /TRACE   |
| NOCQSSHUT   |               |            | /CHECKPOINT  |

Table 79. Command keywords and their synonyms (continued)

| IMS keyword | Synonym | OM keyword | Commands that support this keyword   |
|-------------|---------|------------|--|
| NODBALLOC   |         |            | /START   |
| NODE        |         |            | /ACTIVATE<br>/ASSIGN<br>/BROADCAST<br>/CHANGE<br>/CLSDST<br>/COMPT<br>/DEQUEUE<br>/DIAGNOSE<br>/DISPLAY<br>/END<br>/EXCLUSIVE<br>/EXIT<br>/IDLE<br>/LOCK<br>/OPNDST<br>/QUIESCE<br>/START<br>/STOP<br>/TEST<br>/TRACE<br>/UNLOCK |
| NOFEOV      |         |            | /DBDUMP<br>/DBRECOVERY   |
| NOOPEN      |         |            | /START   |
| NOPFA       |         |            | /DBDUMP<br>/DBRECOVERY<br>/STOP  |
| NOREVERSE   |         |            | /RTAKEOVER   |
| NOSAVE      |         |            | /ASSIGN<br>/CHANGE   |
| NOSHUT      | NOS     |            | /IDLE  |
| NOTRANAUTH  |         |            | /ERESTART<br>/NRESTART   |
| NOTRDY      |         |            | /COMPT<br>/RCOMPT  |
| NOUSER      |         |            | /ERESTART<br>/NRESTART   |
| NPRI        |         |            | /ASSIGN<br>CREATE TRAN<br>CREATE TRANDESC  |

Table 79. Command keywords and their synonyms (continued)

| <b>IMS keyword</b> | <b>Synonym</b> | <b>OM keyword</b> | <b>Commands that support this keyword</b>  |
|--------------------|----------------|-------------------|--|
| OASN               |                |                   | /CHANGE<br>/DISPLAY  |
| ODBM               |                |                   | QUERY<br>UPDATE  |
| OFFLINE            |                |                   | /RECOVER   |
| OLC                |                |                   | INITIATE<br>QUERY<br>TERMINATE   |
| OLDS               |                |                   | /DISPLAY<br>/START<br>/STOP<br>/SWITCH   |
| OLREORG            |                | OLREORG           | INITIATE<br>/INITIATE<br>QUERY<br>/QUERY<br>TERMINATE<br>/TERMINATE<br>UPDATE<br>/UPDATE |
| OPEN               |                |                   | /START   |

Table 79. Command keywords and their synonyms (continued)

| IMS keyword | Synonym  | OM keyword | Commands that support this keyword   |
|-------------|----------|------------|--|
| OPTION      |          | OPTION     | DELETE DB<br>DELETE DBDESC<br>DELETE OTMADESC<br>DELETE PGM<br>DELETE PGMDESC<br>DELETE RTC<br>DELETE RTCDESC<br>DELETE TRAN<br>DELETE TRANDESC<br>/DIAGNOSE<br>EXPORT<br>IMPORT<br>INITIATE OLC<br>INITIATE OLREORG<br>QUERY AREA<br>QUERY LTERM<br>QUERY OTMADESC<br>QUEUE LTERM<br>QUEUE TRAN<br>TERMINATE OLREORG<br>/TRACE<br>UPDATE AREA<br>UPDATE DATAGRP<br>UPDATE DB<br>UPDATE DBDESC<br>UPDATE IMS<br>UPDATE MSLINK<br>UPDATE ODBM<br>UPDATE OLREORG<br>UPDATE PGM<br>UPDATE PGMDESC<br>UPDATE RTC<br>UPDATE RTCDESC<br>UPDATE TRAN<br>UPDATE TRANDESC |
| OSAMGTF     |          |            | /DISPLAY<br>/TRACE   |
| OTMA        |          |            | /DISPLAY<br>/SECURE<br>/START<br>/STOP   |
| OTMADESC    |          |            | CREATE<br>DELETE<br>QUERY<br>UPDATE  |
| OUTBND      | OUTBOUND |            | /CHANGE  |

Table 79. Command keywords and their synonyms (continued)

| <b>IMS keyword</b> | <b>Synonym</b>            | <b>OM keyword</b> | <b>Commands that support this keyword</b>          |
|--------------------|---------------------------|-------------------|--|
| OUTPUT             |                           |                   | /ASSIGN<br>/DISPLAY<br>/START<br>/STOP<br>/TRACE   |
| OVERFLOWQ          | OFLWQ                     | OVERFLOWQ         | /DISPLAY   |
| OVERRIDE           | OVER                      |                   | /ERESTART  |
| PARLIM             |                           |                   | /ASSIGN<br>CREATE TRAN<br>CREATE TRANDESC          |
| PASSWORD           | PASSWORDS,<br>PSWD, PSWDS | PSWD              | /CHANGE<br>/DELETE<br>/MODIFY PREPARE<br>/NRESTART |
| PCH                |                           |                   | /COMPT<br>/RCOMPT                                  |
| PDS                |                           |                   | /COMPT<br>/RCOMPT                                  |
| PGMTYPE            |                           |                   | CREATE PGM<br>CREATE PGMDESC                       |
| PHASE              |                           |                   | INITIATE OLC                                       |
| PI                 |                           |                   | /DISPLAY<br>/TRACE                                 |
| PITR               |                           |                   | /RECOVER   |
| PLCT               |                           |                   | CREATE TRAN<br>CREATE TRANDESC                     |
| PLCTTIME           |                           |                   | CREATE TRAN<br>CREATE TRANDESC                     |
| PLEXPARM           |                           |                   | UPDATE IMS   |
| PLMCT              | PLCT                      | PLCT              | /ASSIGN  |
| POOL               |                           |                   | /DISPLAY   |
| PREPARE            |                           |                   | /MODIFY  |
| PRIORITY           | PRTY                      |                   | /DISPLAY   |

Table 79. Command keywords and their synonyms (continued)

| IMS keyword | Synonym                                | OM keyword | Commands that support this keyword  |
|-------------|--|------------|---|
| PROGRAM     | PGM, PGMS,<br>PROG, PROGRAMS,<br>PROGS | PGM        | CREATE PGM<br>CREATE PGMDESC<br>CREATE TRAN<br>CREATE TRANDESC<br>DELETE LE<br>DELETE PGM<br>DELETE PGMDESC<br>/DIAGNOSE<br>DISPLAY<br>/LOCK<br>QUERY LE<br>QUERY PGM<br>QUERY PGMDESC<br>/START<br>/STOP<br>/TRACE<br>/UNLOCK<br>UPDATE LE<br>UPDATE PGM<br>UPDATE PGMDESC |
| PRT         |  |            | /COMPT<br>/RCOMPT   |
| PRTKN       | PRK                                    |            | /CHANGE CCTL  |
| PSB         |  |            | /DISPLAY<br>QUERY ODBM<br>/TRACE  |
| PSWD        |  |            | INITIATE OLC  |
| PTERM       | PTERMS                                 | PTERM      | /ASSIGN<br>/BROADCAST<br>/DEQUEUE<br>/DISPLAY<br>/END<br>/EXCLUSIVE<br>/EXIT<br>/LOCK<br>/LOOPTEST<br>/MONITOR<br>/PSTOP<br>/PURGE<br>/START<br>/STOP<br>/TEST<br>/UNLOCK   |
| PURGE       |  |            | /CHECKPOINT<br>/DEQUEUE<br>/PSTOP   |

Table 79. Command keywords and their synonyms (continued)

| <b>IMS keyword</b> | <b>Synonym</b>   | <b>OM keyword</b> | <b>Commands that support this keyword</b>                                       |
|--------------------|--|-------------------|---|
| PURGE1             | FIRST, SINGLE,<br>SNGL   |                   | /DEQUEUE  |
| Q                  | QS, QUEUE,<br>QUEUES   | Q                 | /DISPLAY<br>/OPNDST   |
| QCNT               |  |                   | /DISPLAY<br>QUERY LTERM<br>QUERY MSNAME<br>QUERY TRAN                           |
| QMGR               |  |                   | /TRACE TABLE  |
| QUIESCE            |  |                   | /CHECKPOINT   |
| RCVTIME            |  |                   | /RECOVER  |
| RCVTOKEN           |  |                   | /RECOVER  |
| RDDSDSN            |  |                   | EXPORT  |
| RDR                |  |                   | /COMPT<br>/RCOMPT   |
| READNUM            |  |                   | /RECOVER  |
| READY              |  |                   | /COMPT<br>/RCOMPT   |
| RECOVER            |  |                   | CREATE TRAN<br>CREATE TRANDESC  |
| RECOVERY           | REC  | RECOVERY          | /DISPLAY  |
| RECOVGRP           | RCVGRP   |                   | /RECOVER  |
| REGION             | REGIONS, REG,<br>REGS, MSGREG,<br>MSGREGS,<br>MSGREGION,<br>MSREGIONS,<br>THREAD | REGION            | /ASSIGN<br>/DIAGNOSE<br>/DISPLAY<br>/PSTOP<br>/START<br>/STOP<br>/TRACE MONITOR |
| REMOTE             |  |                   | CREATE TRAN<br>CREATE TRANDESC<br>/DISPLAY<br>UPDATE DBDESC                     |
| REMOVE             | REM  | REMOVE            | /RECOVER  |
| RESET              |  |                   | /CHANGE   |

Table 79. Command keywords and their synonyms (continued)

| <b>IMS keyword</b> | <b>Synonym</b> | <b>OM keyword</b> | <b>Commands that support this keyword</b>                           |
|--------------------|----------------|-------------------|---|
| RESIDENT           |                |                   | CREATE DB<br>CREATE DBDESC<br>CREATE PGM<br>CREATE PGMDESC          |
| RESP               |                |                   | CREATE TRAN<br>CREATE TRANDESC                                      |
| RTCODE             | RTC            | RTC               | /DISPLAY<br>/START<br>/STOP   |
| SAVE               |                |                   | /ASSIGN   |
| SB                 |                |                   | /START<br>/STOP   |
| SCOPE              |                |                   | IMPORT<br>UPDATE AREA<br>UPDATE DATAGRP<br>UPDATE DB<br>UPDATE TRAN |
| SCHD               |                |                   | /TRACE MONITOR  |
| SCHDTYPE           |                |                   | CREATE PGM<br>CREATE PGMDESC  |
| SCIMEMBER          |                |                   | QUERY ODBM  |
| SEGNO              |                |                   | /ASSIGN<br>CREATE TRAN<br>CREATE TRANDESC                           |
| SEGSIZE            | SEGSZ          | SEGSZ             | /ASSIGN<br>CREATE TRAN<br>CREATE TRANDESC                           |
| SERIAL             |                |                   | CREATE TRAN<br>CREATE TRANDESC                                      |
| SERVGRP            | SG             | SERVGRP           | /START<br>/STOP   |



Table 79. Command keywords and their synonyms (continued)

| IMS keyword | Synonym | OM keyword | Commands that support this keyword  |
|-------------|---------|------------|---|
| SET         |         |            | CREATE DB<br>CREATE DBDESC<br>CREATE IMSCON<br>CREATE OTMADESC<br>CREATE PGM<br>CREATE PGMDESC<br>CREATE RTC<br>CREATE RTCDESC<br>CREATE TRAN<br>CREATE TRANDESC<br>/DIAGNOSE<br>EXPORT<br>INITIATE OLREORG<br>/TRACE<br>UPDATE DB<br>UPDATE DBDESC<br>UPDATE IMSCON, UPDATE LE<br>UPDATE MSLINK<br>UPDATE MSNAME<br>UPDATE MSPLINK<br>UPDATE OLREORG<br>UPDATE OTMADESC<br>UPDATE PGM<br>UPDATE PGMDESC<br>UPDATE RTC<br>UPDATE RTCDSC<br>UPDATE TRAN<br>UPDATE TRANDESC |
| SHAREDQ     | SHRQ    | SHAREDQ    | /CQCHKPT<br>/CQSET  |

Table 79. Command keywords and their synonyms (continued)

| IMS keyword | Synonym | OM keyword | Commands that support this keyword   |
|-------------|---------|------------|--|
| SHOW        |         |            | /DIAGNOSE<br>QUERY AREA<br>QUERY DB<br>QUERY DBDESC<br>QUERY IMS<br>QUERY IMSPLEX<br>QUERY LE<br>QUERY LTERM<br>QUERY MEMBER<br>QUERY MSLINK<br>QUERY MSNAME<br>QUERY MSPLINK<br>QUERY NODE<br>QUERY ODBM<br>QUERY OTMADESC<br>QUERY OTMATI<br>QUERY PGM<br>QUERY PGMDESC<br>QUERY POOL<br>QUERY OLC<br>QUERY OLREORG<br>QUERY RTC<br>QUERY RTCDESC<br>QUERY STRUCTURE<br>QUERY TRAN<br>QUERY TRANDESC<br>QUERY USER<br>QUERY USERID |
| SHUTDOWN    |         |            | /CQSET<br>/DISPLAY   |
| SIDE        |         |            | /CHANGE  |
| SIDL        |         |            | CREATE TRAN<br>CREATE TRANDESC   |
| SIDR        |         |            | CREATE TRAN<br>CREATE TRANDESC   |
| SLDSREAD    |         |            | /START<br>/STOP  |
| SMEM        |         |            | QUERY OTMADESC   |
| SMSOPTS     |         |            | /RECOVER   |
| SNAP        |         |            | /DIAGNOSE  |
| SNAPQ       |         |            | /CHECKPOINT  |
| SNGLSIGN    |         |            | /ERESTART<br>/NRESTART   |

Table 79. Command keywords and their synonyms (continued)

| <b>IMS keyword</b> | <b>Synonym</b> | <b>OM keyword</b> | <b>Commands that support this keyword</b>  |
|--------------------|----------------|-------------------|--|
| SOURCE             |                |                   | IMPORT   |
| SPASZ              |                |                   | CREATE TRAN<br>CREATE TRANDESC   |
| SPATRUNC           |                |                   | CREATE TRAN<br>CREATE TRANDESC   |
| SQTT               |                |                   | /TRACE TABLE   |
| SSM                |                |                   | /START   |
| STAGLOBAL          |                |                   | /RECOVER   |
| STALOCAL           |                |                   | /RECOVER   |
| START              | STA            | START             | /RECOVER<br>UPDATE AREA<br>UPDATE DATAGRP<br>UPDATE DB<br>UPDATE MSLINK<br>UPDATE MSNAME<br>UPDATE MSPLINK<br>UPDATE ODBM<br>UPDATE PGM<br>UPDATE RTC<br>UPDATE TRAN   |
| STARTTIME          |                |                   | EXPORT   |
| STATISTICS         |                |                   | /CHECKPOINT<br>/CQQUERY<br>QUERY STRUCTURE   |
| STATUS             |                |                   | /DISPLAY<br>QUERY AREA<br>QUERY DB<br>QUERY IMSPLEX<br>QUERY LTERM<br>QUERY MEMBER<br>QUERY MSLINK<br>QUERY MSNAME<br>QUERY MSPLINK<br>QUERY NODE<br>QUERY ODBM<br>QUERY PGM<br>QUERY OLREORG<br>QUERY RTC<br>QUERY TRAN<br>QUERY USER |

Table 79. Command keywords and their synonyms (continued)

| IMS keyword  | Synonym                  | OM keyword | Commands that support this keyword   |
|--------------|--------------------------|------------|--|
| STOP         | STO                      | STOP       | /RECOVER<br>UPDATE AREA<br>UPDATE DATAGRP<br>UPDATE DB<br>UPDATE MSLINK<br>UPDATE MSNAME<br>UPDATE MSPLINK<br>UPDATE ODBM<br>UPDATE PGM<br>UPDATE RTC<br>UPDATE TRAN |
| STRUCTURE    | STRUC                    | STRUCTURE  | /CQCHKPT<br>/CQQUERY<br>/CQSET<br>/DIAGNOSE<br>/DISPLAY  |
| SUBSYS       | SUBSYSTEM,<br>SUBSYSTEMS | SUBSYS     | /CHANGE<br>/DISPLAY<br>/START<br>/STOP   |
| SURVEILLANCE | SUR, SURV,<br>SURVEIL    | SURV       | /CHANGE<br>/START<br>/STOP   |
| SUSPEND      |                          |            | /DEQUEUE   |
| SYNCLEVEL    | SYNCLV                   |            | /CHANGE<br>QUERY OTMATI  |
| SYNCSESS     | SYNC                     |            | /CHANGE  |
| SYSID        |                          |            | /BROADCAST<br>/DISPLAY<br>/MSASSIGN<br>/MSVERIFY   |
| SYSTEM       |                          |            | /CQCHKPT<br>/SWITCH<br>/UNLOCK   |
| TABLE        |                          |            | /DISPLAY<br>/TRACE   |
| TAKEOVER     | TKO, TKOVR               |            | /TRACE   |
| TARGET       |                          |            | EXPORT   |

Table 79. Command keywords and their synonyms (continued)

| IMS keyword     | Synonym                                 | OM keyword | Commands that support this keyword   |
|-----------------|---|------------|--|
| TCO             |   |            | /DISPLAY<br>/TRACE   |
| TDS             |   |            | /COMPT<br>/RCOMPT  |
| TERMINAL        | TER, TERM,<br>TERMINALS,<br>TERMS, TERS | TERMINAL   | INITIATE OLC<br>/SMCOPY  |
| THREAD          |   |            | /START<br>/STOP  |
| TIMEOUT         | TIMO                                    |            | /CHANGE<br>/DISPLAY<br>/TRACE  |
| TIMEOVER        |   |            | /DISPLAY   |
| TMEMBER         | TMEM                                    | TMEM       | /DEQUEUE<br>/DISPLAY<br>/EXIT<br>QUERY OTMADESC<br>QUERY OTMATI<br>/START<br>/STOP<br>/TRACE |
| TPIPE           | TPI                                     |            | /DEQUEUE<br>/DISPLAY<br>QUERY OTMADESC<br>QUERY OTMATI<br>/START<br>/STOP<br>/TRACE          |
| TPNAME          | TP, TPN                                 |            | /ALLOCATE<br>/CHANGE<br>/DEQUEUE<br>/DISPLAY<br>/START<br>/STOP<br>/TRACE                    |
| TRACE           |   |            | /DISPLAY   |
| TRACKING        |   |            | /DISPLAY   |
| TRACKING STATUS |   |            | /DISPLAY   |
| TRANAUTH        |   |            | /ERESTART<br>/NRESTART   |

Table 79. Command keywords and their synonyms (continued)

| IMS keyword | Synonym  | OM keyword | Commands that support this keyword  |
|-------------|--|------------|---|
| TRANCMDS    |  |            | INITIATE OLC  |
| TRANSACTION | TRANS, TRAN,<br>TRANSACTIONS,<br>TRANCODE,<br>TRANCODES, TRS | TRAN       | /ASSIGN<br>/CHANGE<br>CREATE TRAN<br>CREATE TRANDESC<br>DELETE LE<br>DELETE TRAN<br>DELETE TRANDESC<br>/DEQUEUE<br>/DIAGNOSE<br>/DISPLAY<br>/LOCK<br>/MSASSIGN<br>/PSTOP<br>/PURGE<br>QUERY LE<br>QUERY OTMATI<br>QUERY TRAN<br>QUERY TRANDESC<br>/SET<br>/START<br>/STOP<br>/TRACE<br>/UNLOCK<br>UPDATE LE<br>UPDATE TRAN<br>UPDATE TRANDESC |
| TRANSTAT    |  |            | CREATE PGM<br>CREATE PGMDESC<br>CREATE TRAN<br>CREATE TRANDESC  |
| TRAP        |  |            | /DISPLAY<br>/TRACE  |
| TRS         |  |            | /DISPLAY MODIFY   |

Table 79. Command keywords and their synonyms (continued)

| IMS keyword | Synonym | OM keyword | Commands that support this keyword   |
|-------------|---------|------------|--|
| TYPE        |         |            | /CHANGE<br>CREATE IMSCON<br>EXPORT<br>IMPORT<br>INITIATE OLC<br>QUERY DB<br>QUERY IMS<br>QUERY IMSCON<br>QUERY IMSPLEX<br>QUERY MEMBER<br>QUERY MSPLINK<br>QUERY ODBM<br>QUERY OTMADESC<br>QUERY POOL<br>QUERY STRUCTURE<br>UPDATE IMSCON<br>UPDATE ODBM |
| UDATA       |         |            | /OPNDST  |
| UDS         |         |            | /COMPT<br>/RCOMPT  |
| UNITYPE     |         |            | /TRACE   |
| UNPLAN      |         |            | /RTAKEOVER   |
| UOR         |         |            | /CHANGE<br>/DISPLAY  |
| USEDDBDS    | USEAREA |            | /RECOVER   |
| USER        | SUBPOOL | USER       | /ASSIGN<br>/BROADCAST<br>/CHANGE<br>/CLSDST<br>/COMPT<br>/DEQUEUE<br>/DIAGNOSE<br>/DISPLAY<br>/END<br>/ERESTART<br>/EXCLUSIVE<br>/EXIT<br>/NRESTART<br>/OPNDST<br>/QUIESCE<br>/START<br>/STOP<br>/TEST<br>/TRACE   |
| USERD       | USRD    |            | /OPNDST  |

Table 79. Command keywords and their synonyms (continued)

| IMS keyword | Synonym         | OM keyword | Commands that support this keyword                 |
|-------------|-----------------|------------|--|
| USERID      |                 |            | DELETE LE<br>QUERY LE<br>QUERY OTMATI<br>UPDATE LE |
| VERIFY      |                 |            | /RECOVER   |
| VGRS        | VGR             | VGR        | /STOP  |
| VID         |                 |            | /COMPT<br>/RCOMPT                                  |
| VOLUME      |                 |            | /TRACE   |
| VTAMPOOL    | VPL             |            | /ASSIGN  |
| WADS        |                 |            | /STOP<br>/SWITCH                                   |
| WFI         |                 |            | CREATE TRAN<br>CREATE TRANDESC                     |
| WPM1        |                 |            | /COMPT   |
| WPM2        |                 |            | /COMPT   |
| WPM3        |                 |            | /COMPT   |
| XRCTrack    |                 |            | /START<br>/STOP                                    |
| XTRC        | XTRACE, EXTRACE |            | /DISPLAY TRACE                                     |

**Related reference**

[IMS Command Language Modification facility \(DFSCKWD0\) \(Exit Routines\)](#)



## Chapter 3. Commands and keywords used in DBCTL

You can find the list of supported commands and keywords that are valid in the Database Control (DBCTL) environment. You can also find the links to the detailed information about the supported commands.

The following table lists commands and keywords that are valid in the DBCTL environment. These commands are also valid in a DB/DC environment.

When you want to use these commands in a DBCTL environment, you can find some examples of using the commands in [“Using commands in a DBCTL environment”](#) on page 7.

Table 80. Commands and keywords valid in DBCTL

| Commands                       | Keywords  | Topic   |
|--------------------------------|---|---|
| /CHANGE                        | ABORT, AUTOLOGON, CCTL, COMMIT, FDR, OASN, PASSWORD, PRTKN, RESET, SUBSYS, TIMEOUT  | <a href="#">Chapter 12, “/CHANGE commands,”</a> on page 129       |
| /CHECKPOINT                    | ABDUMP, FREEZE, PURGE, STATISTICS   | <a href="#">Chapter 13, “/CHECKPOINT command,”</a> on page 153    |
| CREATE                         | PGMDESC, PGM  | <a href="#">Chapter 19, “CREATE commands,”</a> on page 175        |
| /DBDUMP                        | DB, GLOBAL, LOCAL, NOFEOV, NOPFA  | <a href="#">Chapter 20, “/DBDUMP command,”</a> on page 329        |
| /DBRECOVERY                    | AREA, DB, DATAGRP, GLOBAL, LOCAL, NOFEOV, NOPFA   | <a href="#">Chapter 21, “/DBRECOVERY command,”</a> on page 335    |
| /DELETE                        | DB, PASSWORD, PGM   | <a href="#">Chapter 22, “/DELETE command,”</a> on page 343        |
| DELETE                         | DB, DBDESC, DEFN, LE, PGM, PGMDESC  | <a href="#">Chapter 23, “DELETE commands,”</a> on page 345        |
| /DEQUEUE                       | AOITOKEN  | <a href="#">Chapter 24, “/DEQUEUE command,”</a> on page 451       |
| /DIAGNOSE                      | AREA, ADDRESS, BLOCK, DB, JOBNAME, MODULE, OPTION, PGM, REGION, SET, SHOW, SNAP   | <a href="#">Chapter 26, “/DIAGNOSE commands,”</a> on page 461     |
| /DISPLAY                       | ACTIVE, AOITOKEN, AREA, BKERR, CCTL, CPLOG, DB, DBD, FDR, FPVIRTUAL, HSSP, INDOUBT, MADSIOT, MODIFY, MONITOR, OASN, OLDS, OSAMGTF, PI, POOL, PGM, PSB, RECOVERY, REGION, SHUTDOWN, STATUS, SUBSYS, TABLE, TCO, TRACE, TRACKING STATUS, XTRC | <a href="#">Chapter 27, “/DISPLAY commands,”</a> on page 499      |
| /ERESTART                      | CHECKPOINT, COLDBASE, COLDSYS, FORMAT, NOBMP, OVERRIDE  | <a href="#">Chapter 29, “/ERESTART command,”</a> on page 725      |
| EXPORT                         | DEFN, ENDTIME, NAME, OPTION, RDDSDSN, SET, STARTTIME, TARGET, TYPE  | <a href="#">Chapter 32, “EXPORT command,”</a> on page 741         |
| IMPORT DEFN<br>SOURCE(CATALOG) | DEFN, FOR, OPTION, SOURCE   | <a href="#">“IMPORT DEFN SOURCE(CATALOG) command”</a> on page 777 |

Table 80. Commands and keywords valid in DBCTL (continued)

| Commands                         | Keywords  | Topic   |
|----------------------------------|---|---|
| IMPORT DEFN<br>SOURCE(REPO RDDS) | DEFN, NAME, OPTION, RDDS,DSN, SCOPE,<br>SOURCE, TYPE  | <a href="#">“IMPORT DEFN SOURCE(REPO  <br/>RDDS) command” on page 803</a> |
| INITIATE                         | OLC, OLREORG  | <a href="#">Chapter 37, “INITIATE<br/>commands,” on page 841</a>          |
| /LOCK                            | DB, PGM   | <a href="#">Chapter 38, “/LOCK command,” on<br/>page 889</a>              |
| /LOG                             |   | <a href="#">Chapter 39, “/LOG command,” on<br/>page 895</a>               |
| /MODIFY                          | ABORT, COMMIT, PASSWORD, PREPARE  | <a href="#">Chapter 41, “/MODIFY command,”<br/>on page 899</a>            |
| /NRESTART                        | CHECKPOINT, FORMAT  | <a href="#">/NRESTART command<br/>(Commands)</a>                          |
| /PSTOP                           | AOITOKEN, JOBNAME, REGION   | <a href="#">/PSTOP command (Commands)</a>                                 |
| QUERY                            | AREA, DB, DBDESC, IMS, LE, MEMBER,<br>ODBM, OLC, OLREORG, PGM, PGMDESC, POOL,<br>USEREXIT   | <a href="#">QUERY commands (Commands)</a>                                 |
| /RECOVER                         | ALLENTRIES, AREA, CAGROUP, DB, DBDS,<br>DBDSGRP, ERRORABORT, ERRORCONT,<br>NOCHECK, OFFLINE, PITR, RCVTIME,<br>RCVTOKEN, READNUM, RECOVGRP, REMOVE,<br>SMSOPTS, STAGLOBAL, STALOCAL, START, STOP,<br>USEAREA, USEDDBS, VERIFY       | <a href="#">/RECOVER commands<br/>(Commands)</a>                          |
| REFRESH                          | USEREXIT  | <a href="#">REFRESH USEREXIT command<br/>(Commands)</a>                   |
| /RMxxxxxx                        |   | <a href="#">/RMxxxxxx commands<br/>(Commands)</a>                         |
| /SSR                             |   | <a href="#">/SSR command (Commands)</a>                                   |
| /START                           | ACCESS, AREA, AUTOARCH, DB, DATAGRP,<br>DBALLOC, GLOBAL, ISOLOG, JOBNAME,<br>LOCAL, MADSIOT, NOBACKOUT, NODBALLOC,<br>NOOPEN, OLDS, OPEN, PGM, REGION, SB,<br>SERVGRP, SLDSREAD, SSM, SUBSYS, THREAD,<br>TRKAUTOARCH, WADS, XRCTACK | <a href="#">/START commands (Commands)</a>                                |
| /STOP                            | ABDUMP, ADS, AREA, AUTOARCH, CANCEL, DB,<br>DATAGRP, GLOBAL, JOBNAME, LOCAL, MADSIOT,<br>NOPFA, OLDS, PGM, REGION, SB, SERVGRP,<br>SLDSREAD, SUBSYS, WADS, XRCTACK  | <a href="#">/STOP commands (Commands)</a>                                 |
| TERMINATE                        | OLC, OLREORG  | <a href="#">TERMINATE OLC command<br/>(Commands)</a>                      |
| /TRACE                           | COMP, MONITOR, NOCOMP, OPTION, OSAMGTF,<br>PI, PGM, PSB, SET, TABLE, TCO, VOLUME  | <a href="#">/TRACE commands (Commands)</a>                                |
| /UNLOCK                          | DB, PGM   | <a href="#">/UNLOCK commands (Commands)</a>                               |
| UPDATE                           | AREA, DB, DBDESC, DATAGRP, IMS, LE, ODBM,<br>OLREORG, PGM, PGMDESC, POOL  | <a href="#">UPDATE commands (Commands)</a>                                |

---

*Table 80. Commands and keywords valid in DBCTL (continued)*

---

| <b>Commands</b> | <b>Keywords</b> | <b>Topic</b>                                |
|-----------------|-----------------|---|
| /VUNLOAD        | AREA            | <a href="#">/VUNLOAD command (Commands)</a> |

---



## Chapter 4. Commands and keywords valid in DCCTL

Commands and keywords that are valid in a Data Communications Control (DCCTL) environment are listed.

The following table lists commands and keywords valid in a Data Communications Control (DCCTL) environment. All commands and keywords are valid in a DB/DC environment.

Table 81. Commands and keywords valid in DCCTL

| Commands    | Keywords  | Topic  |
|-------------|---|--|
| /ACTIVATE   | LINK, NODE  | <a href="#">Chapter 7, “/ACTIVATE command,” on page 99</a>     |
| /ALLOCATE   | LUNAME, MODE, TPNAME  | <a href="#">Chapter 8, “/ALLOCATE command,” on page 101</a>    |
| /ASSIGN     | CLASS, COMPONENT, CPRI, COMPONENT, INPUT, LINE, LCT, LPRI, LTERM, NODE, NOSAVE, NPRI, OUTPUT, PARLIM, PLCT, PTERM, REGION, SAVE, SEGNO, SEGSIZE, TRANSACTION, USER, VTAMPOOL  | <a href="#">Chapter 9, “/ASSIGN command,” on page 103</a>      |
| /BROADCAST  | ACTIVE, LINE, LTERM, MASTER, MSNAME, NODE, PTERM, SYSID, USER   | <a href="#">Chapter 10, “/BROADCAST command,” on page 121</a>  |
| /CANCEL     |   | <a href="#">Chapter 11, “/CANCEL command,” on page 127</a>     |
| /CHANGE     | APPC, ASR, AUTOLOGON, COLDSESS, CPLOG, DESCRIPTOR, DIRECTORY, FORCSESS, ID, INTERVAL, LINK, LOGOND, LUNAME, MAXRGN, MODE, NODE, NOSAVE, OASN, OUTBND, PASSWORD, RESET, SAVE, SIDE, SUBSYS, SURVEILLANCE, SYNCLEVEL, SYNCSESS, TIMEOUT, TPNAME, TRANSACTION, TYPE, UOR, USER | <a href="#">Chapter 12, “/CHANGE commands,” on page 129</a>    |
| /CHECKPOINT | ABDUMP, DUMPQ, FREEZE, LEAVEPLEX, NOCQSSHUT, PURGE, QUIESCE, SNAPQ, STATISTICS  | <a href="#">Chapter 13, “/CHECKPOINT command,” on page 153</a> |
| /CLSDST     | FORCE, NODE, USER   | <a href="#">Chapter 14, “/CLSDST command,” on page 159</a>     |
| /COMPT      | CNS, CRD, NODE, NOTRDY, PCH, PDS, PRT, RDR, READY, TDS, UDS, USER, VID, WPM1, WPM2, WPM3  | <a href="#">Chapter 15, “/COMPT command,” on page 163</a>      |
| /CQCHKPT    | SHAREDQ, STRUCTURE, SYSTEM  | <a href="#">Chapter 16, “/CQCHKPT command,” on page 167</a>    |
| /CQQUERY    | STATISTICS, STRUCTURE   | <a href="#">Chapter 17, “/CQQUERY command,” on page 169</a>    |
| /CQSET      | SHAREDQ, SHUTDOWN, STRUCTURE  | <a href="#">Chapter 18, “/CQSET command,” on page 173</a>      |
| CREATE      | OTMADESC, PGM, PGMDESC, RTC, RTCDESC, TRAN, TRANDESC  | <a href="#">Chapter 19, “CREATE commands,” on page 175</a>     |

Table 81. Commands and keywords valid in DCCTL (continued)

| Commands                         | Keywords   | Topic  |
|----------------------------------|--|--|
| /DELETE                          | LINE, LTERM, NODE, PASSWORD, PGM, PTERM, TERMINAL, TRANSACTION   | <a href="#">Chapter 22, “/DELETE command,” on page 343</a>               |
| DELETE                           | LE, OTMADESC, PGM, PGMDDESC, RTC, RTCDESC, TRAN, TRANDESC  | <a href="#">Chapter 23, “DELETE commands,” on page 345</a>               |
| /DEQUEUE                         | AOITOKEN, LINE, LTERM, LUNAME, MSNAME, NODE, PTERM, PURGE, PURGE1, SUSPEND, TMEMBER, TPIPE, TPNAME, TRANSACTION, USER  | <a href="#">Chapter 24, “/DEQUEUE command,” on page 451</a>              |
| /DIAGNOSE                        | ADDRESS, AOSLOG, BLOCK, JOBNAME, LINE, LINK, LTERM, MODULE, MSNAME, NODE, OPTION, PGM, REGION, RM, SET, SHOW, SNAP, STRUCTURE, TRAN, USER  | <a href="#">Chapter 26, “/DIAGNOSE commands,” on page 461</a>            |
| /DISPLAY                         | ACT, AFFIN, AOITKN, APPC, ASMT, AUTOLOGON, BALGRP, CLASS, CONVERSATION, CPLOG, CQS, DC, DESCRIPTOR, EMHQ, EXIT, HSB, INPUT, LINE, LINK, LTERM, LUNAME, MASTER, MODE, MODIFY, MONITOR, MSGAGE, MSNAME, MSPLINK, NODE, OASN, OLDS, OTMA, OUTPUT, OVERFLOWQ, PGM, POOL, PRIORITY, PGM, PSB, PTERM, Q, QCNT, REGION, REMOTE, RTCODE, SHUTDOWN, STATUS, STRUCTURE, SUBSYS, SYSID, TABLE, TCO, TIMEOUT, TIMEOVER, TMEMBER, TPIPE, TPNAME, TRACE, TRACKING STATUS, TRANSACTION, TRAP, UOR, USER, XTRC | <a href="#">Chapter 27, “/DISPLAY commands,” on page 499</a>             |
| /END                             | LINE, NODE, PTERM, USER  | <a href="#">Chapter 28, “/END command,” on page 723</a>                  |
| /ERESTART                        | BACKUP, BUILDQ, CHECKPOINT, CMDAUTH, CMDAUTHE, COLDCOMM, COLDSYS, FORMAT, MULTSIGN, NOBMP, NOCMDAUTH, NOCMDAUTHE, NOPASSWORD, NOTERMINAL, NOTRANAUTH, NOTRANCMDS, NOUSER, OVERRIDE, PASSWORD, SNGLSIGN, TERMINAL, TRANAUTH, TRANCMDS, USER   | <a href="#">Chapter 29, “/ERESTART command,” on page 725</a>             |
| /EXCLUSIVE                       | LINE, NODE, PTERM, USER  | <a href="#">Chapter 30, “/EXCLUSIVE command,” on page 735</a>            |
| /EXIT                            | CONVERSATION, LINE, NODE, PTERM, USER  | <a href="#">Chapter 31, “/EXIT command,” on page 737</a>                 |
| /FORMAT                          | LTERM  | <a href="#">Chapter 33, “/FORMAT command,” on page 769</a>               |
| /HOLD                            |  | <a href="#">Chapter 34, “/HOLD command,” on page 771</a>                 |
| /IDLE                            | LINE, LINK, NODE, NOSHUT   | <a href="#">Chapter 35, “/IDLE command,” on page 773</a>                 |
| IMPORT DEFN SOURCE(REPO RDDSDSN) | DEFN, NAME, OPTION, RDDSDSN, SCOPE, SOURCE, TYPE   | <a href="#">“IMPORT DEFN SOURCE(REPO   RDDSDSN) command” on page 803</a> |

Table 81. Commands and keywords valid in DCCTL (continued)

| <b>Commands</b> | <b>Keywords</b>  | <b>Topic</b>   |
|-----------------|--|--|
| INITIATE        | OLC, OLREORG   | <a href="#">Chapter 37, “INITIATE commands,” on page 841</a> |
| /LOCK           | LTERM, NODE, PGM, PTERM, TRANSACTION   | <a href="#">Chapter 38, “/LOCK command,” on page 889</a>     |
| /LOG            |  | <a href="#">Chapter 39, “/LOG command,” on page 895</a>      |
| /LOOPTEST       | LINE, PTERM  | <a href="#">Chapter 40, “/LOOPTEST command,” on page 897</a> |
| /MODIFY         | ABORT, COMMIT, LTERM, PASSWORD, PREPARE, TERMINAL, TRANCMDS  | <a href="#">Chapter 41, “/MODIFY command,” on page 899</a>   |
| /MONITOR        | LINE, PTERM  | <a href="#">Chapter 42, “/MONITOR command,” on page 905</a>  |
| /MSASSIGN       | LINK, LOCAL, MSNAME, MSPLINK, SYSID, TRANSACTION   | <a href="#">Chapter 43, “/MSASSIGN command,” on page 907</a> |
| /MSVERIFY       | MSNAME, SYSID  | <a href="#">Chapter 44, “/MSVERIFY command,” on page 911</a> |
| /NRESTART       | BUILDQ, CHECKPOINT, CMDAUTH, CMDAUTHE, FORMAT, MULTSIGN, NOBUILDQ, NOCMDAUTH, NOCMDAUTHE, NOPASSWORD, NOTERMINAL, NOTRANAUTH, NOTRANCMDS, NOUSER, PASSWORD, SNGLSIGN, TERMINAL, TRANAUTH, TRANCMDS, USER | <a href="#">/NRESTART command (Commands)</a>                 |
| /OPNDST         | ID, LOGOND, MODE, NODE, Q, UDATA, USER, USERD  | <a href="#">/OPNDST command (Commands)</a>                   |
| /PSTOP          | AOITOKEN, CLASS, FORCE, JOBNAME, LINE, LINK, LTERM, MSPLINK, PTERM, PURGE, REGION, TRANSACTION   | <a href="#">/PSTOP command (Commands)</a>                    |
| /PURGE          | APPC, CLASS, FPPROG, FPREGION, LINE, LTERM, MSNAME, PTERM, TRANSACTION   | <a href="#">/PURGE command (Commands)</a>                    |
| QUERY           | IMS, LE, LTERM, MEMBER, MSLINK, MSNAME, MSPLINK, NODE, OLC, OTMADESC, OTMATI, PGM, PGMDESC, RTC, RTCDESC, TRAN, TRANDESC, USER, USEREXIT, USERID   | <a href="#">QUERY commands (Commands)</a>                    |
| QUEUE           | LTERM, TRAN  | <a href="#">QUEUE commands (Commands)</a>                    |
| /QUIESCE        | NODE, USER   | <a href="#">/QUIESCE command (Commands)</a>                  |
| /RCLSDST        |  | <a href="#">/RCLSDST command (Commands)</a>                  |
| /RCOMPT         | CNS, NOTRDY, PCH, PDS, PRT, RDR, READY, TDS, UDS, VID  | <a href="#">/RCOMPT command (Commands)</a>                   |
| /RDISPLAY       | MASTER   | <a href="#">/RDISPLAY command (Commands)</a>                 |
| REFRESH         | USEREXIT   | <a href="#">REFRESH USEREXIT command (Commands)</a>          |
| /RELEASE        | CONVERSATION   | <a href="#">/RELEASE command (Commands)</a>                  |

Table 81. Commands and keywords valid in DCCTL (continued)

| Commands  | Keywords   | Topic  |
|-----------|--|--|
| /RESET    |  | <a href="#">/RESET command (Commands)</a>        |
| /RMxxxxxx | LTERM  | <a href="#">/RMxxxxxx commands (Commands)</a>    |
| /RSTART   | CONTINUOUS, LINE, LINK, LOPEN, MODE, MSPLINK, NODE, PTERM, USER  | <a href="#">/RSTART command (Commands)</a>       |
| /SECURE   | APPC, OTMA   | <a href="#">/SECURE command (Commands)</a>       |
| /SET      | CONVERSATION, LTERM, TRANSACTION   | <a href="#">/SET command (Commands)</a>          |
| /SIGN     |  | <a href="#">/SIGN command (Commands)</a>         |
| /SMCOPY   | MASTER, TERMINAL   | <a href="#">/SMCOPY command (Commands)</a>       |
| /SSR      |  | <a href="#">/SSR command (Commands)</a>          |
| /START    | AFFINITY, APPC, AUTOARCH, CLASS, DC, DESC, GRSNAME, INPUT, ISOLOG, JOBNAME, LINE, LTERM, LUNAME, MSNAME, NODE, OLDS, OTMA, OUTPUT, PGM, PTERM, REGION, RTCODE, SERVGRP, SLDSREAD, SSM, SUBSYS, SURVEILLANCE, TMEMBER, TPIPE, TPNAME, TRANSACTION, TRKAUTOARCH, USER, VGR, WADS, XRCTrack | <a href="#">/START commands (Commands)</a>       |
| /STOP     | ABDUMP, APPC, AUTOARCH, BACKUP, CANCEL, CLASS, DESC, DC, INPUT, JOBNAME, LINE, LTERM, LUNAME, MSNAME, NODE, OLDS, OTMA, OUTPUT, PGM, PTERM, REGION, RTCODE, SERVGRP, SLDSREAD, SUBSYS, SURVEILLANCE, THREAD, TMEMBER, TPIPE, TPNAME, TRANSACTION, USER, VGR, WADS, XRCTrack              | <a href="#">/STOP commands (Commands)</a>        |
| TERMINATE | OLC  | <a href="#">TERMINATE OLC command (Commands)</a> |
| /TEST     | LINE, NODE, PTERM, USER  | <a href="#">/TEST command (Commands)</a>         |
| /TRACE    | AUTO, EXIT, INPUT, LEVEL, LINE, LINK, LUNAME, MODULE, MONITOR, MSG, NODE, OPTION, OUTPUT, PGM, SET, TABLE, TAKEOVER, TCO, TIMEOUT, TMEMBER, TPIPE, TPNAME, TRANSACTION, TRAP, UNITYPE, USER, VOLUME  | <a href="#">/TRACE commands (Commands)</a>       |
| /UNLOCK   | LTERM, NODE, PGM, PTERM, SYSTEM, TRANSACTION   | <a href="#">/UNLOCK commands (Commands)</a>      |
| UPDATE    | IMS, LE, MSLINK, MSNAME, MSPLINK, OTMADESC, PGM, PGMDESC, POOL, RTC, RTCDESC, TRAN, TRANDESC   | <a href="#">UPDATE commands (Commands)</a>       |



## Chapter 5. List of reserved words

Some words are used and reserved only for IMS commands.

The following table is a list of words that cannot be used to name resources such as transactions or databases. The words listed in this table are used and reserved only for IMS commands.

*Table 82. Words used and reserved only for IMS commands*

| <b>Commands #1</b> | <b>Commands #2</b> | <b>Commands #3</b> | <b>Commands #4</b> |
|--------------------|--------------------|--------------------|--------------------|
| A                  | ABDUMP             | ABORT              | ACCESS             |
| ACT                | ACTIV              | ACTIVATE           | ACTIVE             |
| ADDS               | ADS                | AFF                | AFFIN              |
| AFFINITY           | AFTER              | AOITKN             | APDB               |
| APMQ               | AOITOKEN           | ALL                | ALLENTRIES         |
| ALLENT             | ALLOC              | ALLOCATE           | ALLOCF             |
| ALLOCS             | APPC               | ARCHIVE            | AREA               |
| ASMT               | ASR                | ASSIGN             | ASSIGNMENT         |
| AUTO               | AUTOARC            | AUTOARCH           | AUTOLOGON          |
| AUTOLGN            | AUTOSR             | BACKOUT            | BACKUP             |
| BALG               | BALGRP             | BKERR              | BLDQ               |
| BLDQS              | BROADCAST          | BU                 | BUILDQ             |
| BUILDQS            | C1INOP             | C2INOP             | C3INOP             |
| C4INOP             | CAGROUP            | CAGRP              | CANCEL             |
| CC                 | CCTL               | CHANGE             | CHECKPOINT         |
| CHECKPT            | CHKPOINT           | CHKPT              | CHNGS              |
| CLASS              | CLS                | CLSDST             | CMDAUTH            |
| CMDAUTHE           | CNS                | COLDB              | COLDBASE           |
| COLDC              | COLDCOMM           | COLDS              | COLDSSESS          |
| COLDSYS            | COMMIT             | COMP               | COMPINOP           |
| COMPONENT          | COMPT              | CON                | CONT               |
| CONTINUOUS         | CONV               | CONVACT            | CONVERSATION       |
| CONVHLD            | CPRI               | CQCHKPT            | CQQUERY            |
| CPLOG              | CQC                | CQQ                | CQS                |
| CQSET              | CRD                | DATABASE           | DATABASES          |
| DATAGROUP          | DATAGRP            | DB                 | DBALLOC            |
| DBD                | DBDS               | DBDSGRP            | DBDUMP             |
| DBR                | DBRECOVERY         | DBS                | DC                 |
| DEACT              | DEADQ              | DELETE             | DELS               |

Table 82. Words used and reserved only for IMS commands (continued)

| Commands #1 | Commands #2 | Commands #3 | Commands #4 |
|-------------|-------------|-------------|-------------|
| DEQUEUE     | DESC        | DESCRIPTOR  | DL/I        |
| DLOG        | DIS         | DISP        | DISPLAY     |
| DIR         | DIRECTORY   | DMS         | DONE        |
| DUMPQ       | DUMPQS      | EEQE        | EMHQ        |
| END         | ERESTART    | ERRORCONT   | EXCL        |
| EXCLUSIVE   | EXIT        | EXTRACE     | FAST        |
| FDR         | FIRST       | FMS         | FMT         |
| FOR         | FORC        | FORCE       | FORCES      |
| FORCSESS    | FORMAT      | FPPROG      | FPREGION    |
| FPRGN       | FPV         | FPVIRTUAL   | FREEZE      |
| GLOBAL      | GRS         | GRSN        | GRSNAME     |
| HOLD        | HOTSTANDBY  | HSB         | HSSP        |
| IAM         | IC          | ICOMPONENT  | ICOMPT      |
| ID          | IDCO        | IDLE        | IND         |
| INDOUBT     | INOP        | INPUT       | INQONLY     |
| INT         | INTERVAL    | INTV        | IOVF        |
| ISOLOG      | JBN         | JOB         | JOBNAME     |
| KEY         | LA          | LATC        | LCT         |
| LEAVEGR     | LEVEL       | LGND        | LINE        |
| LINES       | LINK        | LMCT        | LOC         |
| LOCAL       | LOCK        | LOG         | LOGOND      |
| LOOPTEST    | LOPEN       | LOST        | LPRI        |
| LRTT        | LTERM       | LTERMS      | LU          |
| LUMI        | LUN         | LUNAME      | MADSIOT     |
| MASTER      | MAXRGN      | MESSAGE     | MFST        |
| MFSTEST     | MODE        | MODETABLE   | MODETBL     |
| MODIFY      | MODS        | MODULE      | MON         |
| MONITOR     | MSASSIGN    | MSDB        | MSDBLOAD    |
| MSG         | MSGAGE      | MSGREG      | MSGREGION   |
| MSGREGIONS  | MSGREGS     | MSNAME      | MSPLINK     |
| MSVERIFY    | MULTSIGN    | NBLDQ       | NOBACKOUT   |
| NOBKO       | NOBLDQ      | NOBMP       | NOBUILDQ    |
| NOCHECK     | NOCMDAUTH   | NOCMDAUTHE  | NOCOMP      |
| NODBALLOC   | NODE        | NOFEOV      | NOIN        |

Table 82. Words used and reserved only for IMS commands (continued)

| <b>Commands #1</b> | <b>Commands #2</b> | <b>Commands #3</b> | <b>Commands #4</b> |
|--------------------|--------------------|--------------------|--------------------|
| NONE               | NOOUT              | NOPASSWORD         | NOPFA              |
| NOPSWD             | NOQUEUE            | NOREVERSE          | NOS                |
| NOSAVE             | NOSHUT             | NOTER              | NOTERM             |
| NOTERMINAL         | NOTINIT            | NOTOPEN            | NOTRANAUTH         |
| NOTRANCMD5         | NOTRDY             | NOUSER             | NPRI               |
| NRESTART           | OASN               | OFF                | OFFLINE            |
| OFR                | OLDS               | OLREORG            | ON                 |
| OPNDST             | OPTION             | OSAMGTF            | OTMA               |
| OTMT               | OUTPUT             | OVER               | OVERFLOWQ          |
| OVERRIDE           | OVFLWQ             | PAGE               | PARLIM             |
| PASSWORD           | PASSWORDS          | PCH                | PDS                |
| PGM                | PGMS               | PI                 | PITR               |
| PLCT               | PLMCT              | POOL               | PREL               |
| PREO               | PREPARE            | PRI                | PRIMARY            |
| PRIORITY           | PRK                | PROG               | PROGRAM            |
| PROGRAMS           | PROGS              | PRST               | PRT                |
| PRTKN              | PRTY               | PSB                | PSS                |
| PSTOP              | PSTOPPED           | PSWD               | PSWDS              |
| PTERM              | PTERMS             | PUR                | PURGE              |
| PURGE1             | Q                  | QCNT               | QMGR               |
| QRTT               | QS                 | QUEUE              | QUEUES             |
| QUI                | QUIESCE            | RCLSDST            | RCOMPT             |
| RCS                | RCVTIME            | RCVTOKEN           | RDISPLAY           |
| RDR                | READNUM            | READY              | RECOVERY           |
| RECOVGRP           | REG                | REGION             | REGIONS            |
| REGS               | RELEASE            | RELREQ             | REMOTE             |
| REMOVE             | RESET              | RESP               | RESPINP            |
| RESYNC             | RETR               | RMCHANGE           | RMDELETE           |
| RMGENJCL           | RMINIT             | RMLIST             | RMNOTIFY           |
| RSTART             | RTAKEOVER          | RTC                | RTCODE             |
| SAVE               | SB                 | SCHD               | SEC                |
| SECURE             | SECURITY           | SEGNO              | SEGSIZE            |
| SEGSZ              | SERVGRP            | SET                | SG                 |
| SHAREDQ            | SHRQ               | SHUT               | SHUTDOWN           |

Table 82. Words used and reserved only for IMS commands (continued)

| <b>Commands #1</b> | <b>Commands #2</b> | <b>Commands #3</b> | <b>Commands #4</b> |
|--------------------|--------------------|--------------------|--------------------|
| SIDE               | SIGN               | SIMLOGON           | SINGLE             |
| SMCOPY             | SNAPQ              | SNGL               | SNGLSIGN           |
| SQTT               | SSM                | SSR                | STAGLOBAL          |
| STALOCAL           | STA                | START              | STATIC             |
| STATISTICS         | STATUS             | STO                | STOP               |
| STOPPED            | STRG               | STRUC              | STRUCTURE          |
| SUB                | SUBS               | SUBPOOL            | SUBSYS             |
| SUBSYSTEMEMBER     | SUBSYSTEM          | SUBSYSTEMS         | SUR                |
| SURV               | SURVEIL            | SURVEILLANCE       | SUSPEND            |
| SWITCH             | SYNC               | SYNCLEVEL          | SYNCLV             |
| SYNCESS            | SYSID              | SYSTEM             | TABLE              |
| TAKEOVER           | TCO                | TDS                | TER                |
| TERM               | TERMINAL           | TERMINALS          | TERMINATE          |
| TERMS              | TERS               | TEST               | THREAD             |
| TIMEOUT            | TIMEOVER           | TIMO               | TKO                |
| TKOTRA             | TKOVR              | TMEM               | TMEMBER            |
| TO                 | TP                 | TPI                | TPIPE              |
| TPN                | TPNAME             | TRA                | TRACE              |
| TRACKING           | TRACKING STATUS    | TRAN               | TRANAUTH           |
| TRANCMDs           | TRANCODE           | TRANCODES          | TRANS              |
| TRANSACTION        | TRANSACTIONS       | TRAP               | TRKARCH            |
| TRKAUTOARCH        | TRS                | TYPE               | UDATA              |
| UDS                | UNITYPE            | UNL                | UNLOCK             |
| UNPLAN             | UOR                | USEDDBS            | USER               |
| USERD              | USRD               | VERIFY             | VGR                |
| VGRS               | VID                | VIR                | VOLUME             |
| VPL                | VTAMPOOL           | VUNLOAD            | WADS               |
| WPM1               | WPM2               | WPM3               | XKEY               |
| XTRC               | XTRACE             |                    |                    |

## Chapter 6. IMS type-1 commands that are valid in ETO

The commands that are valid for lterms, nodes, and users in ETO are listed.

The following table lists the type-1 commands that are valid for lterms, nodes, and users in ETO.

Table 83. IMS type-1 commands valid in ETO

| Commands   | Dynamic lterms that are valid | Dynamic nodes that are valid | Dynamic users that are valid |
|------------|-------------------------------|------------------------------|------------------------------|
| /ACTIVATE  |                               | X                            |                              |
| /ASSIGN    | X <sup>"1"</sup> on page 98   |                              | X <sup>"2"</sup> on page 98  |
| /BROADCAST | X                             | X                            | X                            |
| /CHANGE    |                               | X                            | X                            |
| /CLSDST    |                               | X                            | X                            |
| /COMPT     |                               | X                            | X                            |
| /DEQUEUE   | X                             | X                            | X                            |
| /DISPLAY   | X                             | X                            | X                            |
| /END       |                               |                              | X                            |
| /EXCLUSIVE |                               |                              | X                            |
| /EXIT      |                               | X                            | X                            |
| /FORMAT    | X                             |                              |                              |
| /IDLE      |                               | X                            |                              |
| /LOCK      | X                             | X                            |                              |
| /MODIFY    | X                             |                              |                              |
| /OPNDST    |                               | X                            |                              |
| /PSTOP     | X                             |                              |                              |
| /PURGE     | X                             |                              |                              |
| /QUIESCE   |                               | X                            | X                            |
| /RMxxxxxx  | X                             |                              |                              |
| /RSTART    |                               | X                            | X                            |
| /SET       | X                             |                              |                              |
| /SIGN      |                               |                              | X                            |
| /START     | X                             | X                            | X                            |
| /STOP      | X                             | X                            | X                            |
| /TEST      |                               |                              | X                            |
| /TRACE     |                               | X                            |                              |
| /UNLOCK    | X                             | X                            |                              |

---

Table 83. IMS type-1 commands valid in ETO (continued)

---

| Commands | Dynamic lterms that are valid | Dynamic nodes that are valid | Dynamic users that are valid |
|----------|-------------------------------|------------------------------|------------------------------|
|----------|-------------------------------|------------------------------|------------------------------|

---

**Notes:**

1. Only valid for /ASSIGN LTERM USER.
  2. Only valid for /ASSIGN USER.
-

## Chapter 7. /ACTIVATE command

The **/ACTIVATE** command is used to activate VTAM nodes or MSC links with a **VTAM "VARY NET, ACTIVE"** command.

The **/ACTIVATE** command can also be used to undo the conditions set by the **/IDLE** command.

Subsections:

- [“Environment” on page 99](#)
- [“Syntax” on page 99](#)
- [“Keywords” on page 99](#)
- [“Usage notes” on page 99](#)
- [“Examples” on page 100](#)

### Environment

The following table lists the environments (DB/DC, DBCTL, and DCCTL) in which you can use the command and keywords.

Table 84. Valid environments for the /ACTIVATE command and keywords

| Command / Keywords | DB/DC | DBCTL | DCCTL |
|--------------------|-------|-------|-------|
| <b>/ACTIVATE</b>   | X     |       | X     |
| LINK               | X     |       | X     |
| NODE               | X     |       | X     |

### Syntax

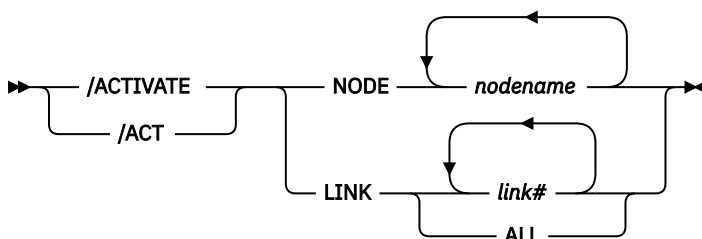

### Keywords

The following keywords apply to the **/ACTIVATE** command:

#### LINK

Specifies the MSC links to be activated.

#### NODE

Specifies the VTAM nodes to be activated.

### Usage notes

The **/ACTIVATE** command is used with the IMS VTAM I/O Timeout Detection Facility.

This command can be issued to an IMSplex using the Batch SPOC utility.

## Examples

The following are examples of the **/ACTIVATE** command:

### ***Example 1 for /ACTIVATE command***

Entry ET:

```
/ACTIVATE LINK 1
```

Response ET:

```
DFS058I  ACTIVATE COMMAND COMPLETED
```

Explanation: Link 1 has been activated.

### ***Example 2 for /ACTIVATE command***

Entry ET:

```
/ACTIVATE NODE ABC
```

Response ET:

```
DFS058I  ACTIVATE COMMAND COMPLETED
```

Explanation: Node ABC has been activated.



## Chapter 8. /ALLOCATE command

Use the **/ALLOCATE** command for delivering asynchronous output when the LU 6.2 device is available. The command can be originated by the remote LU 6.2 device for this purpose.

**/ALLOCATE** is a multisegment command similar to the **/OPNDST** command for VTAM terminals. It causes IMS to allocate a conversation to the specified LUNAME and TPNAME if any output is queued in IMS for that destination. If no such output exists, the command has no effect and (in a non-shared-queues environment) an error message is issued.

Subsections:

- [“Environment” on page 101](#)
- [“Syntax” on page 101](#)
- [“Keywords” on page 101](#)
- [“Usage notes” on page 102](#)

### Environment

The following table lists the environments (DB/DC, DBCTL, and DCCTL) in which you can use the command and keywords.

Table 85. Valid environments for the /ALLOCATE command and keywords

| Command / Keywords | DB/DC | DBCTL | DCCTL |
|--------------------|-------|-------|-------|
| <b>/ALLOCATE</b>   | X     |       | X     |
| LUNAME             | X     |       | X     |
| MODE               | X     |       | X     |
| TPNAME             | X     |       | X     |

### Syntax

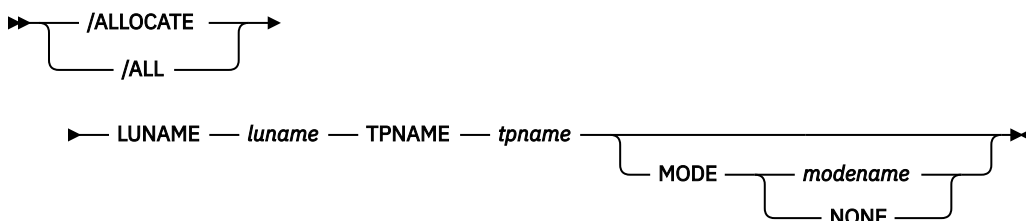

### Keywords

The following keywords apply to the **ALLOCATE** command:

#### LUNAME

Specifies the LU name of the LU 6.2 application program that is to be allocated. A network-qualified LU name is optional for the LUNAME keyword

#### MODE

Identifies the LOGON MODE table entry that VTAM uses to determine the session operating characteristics. NONE, which can be used as a MODE keyword parameter, resets the MODE field to its null state.

**TPNAME**

Specifies the TP name of the LU 6.2 application program that is to be allocated.

**Usage notes**

**/ALLOCATE** requires an end-of-message (EOM) indicator. An end-of-segment (EOS) indicator must be included for all segments preceding the last segment.

After the syntax checking of the **/ALLOCATE** command is successfully completed, the DFS058 ALLOCATE COMMAND COMPLETED message is issued and processing of the command continues asynchronously.

This command can be issued to an IMSplex using the Batch SPOC utility.

**Related reference**

“Command keywords and their synonyms” on page 59

All IMS command keywords and their synonyms, as well as keywords supported by the OM API, are listed. The list covers command keywords for the OM command processing clients such as IMS, ODBM, IMSCON, and RM.

## Chapter 9. /ASSIGN command

The **/ASSIGN** command alters the relationships between various IMS resources and resets certain values specified during IMS system definition.

Subsections:

- [“Environment” on page 103](#)
- [“Syntax” on page 104](#)
- [“Keywords” on page 106](#)
- [“Usage notes” on page 112](#)
- [“/ASSIGN in an IMSplex” on page 113](#)
- [“Equivalent IMS type-2 commands” on page 114](#)
- [“Examples” on page 115](#)

### Environment

The following table lists the environments (DB/DC, DBCTL, and DCCTL) in which you can use the command and keywords.

| <b>Command / Keywords</b> | <b>DB/DC</b> | <b>DBCTL</b> | <b>DCCTL</b> |
|---------------------------|--------------|--------------|--------------|
| <b>/ASSIGN</b>            | X            |              | X            |
| CLASS                     | X            |              | X            |
| COMPONENT                 | X            |              | X            |
| CPRI                      | X            |              | X            |
| ICOMPONENT                | X            |              | X            |
| INPUT                     | X            |              | X            |
| LINE                      | X            |              | X            |
| LCT                       | X            |              | X            |
| LPRI                      | X            |              | X            |
| LTERM                     | X            |              | X            |
| NODE                      | X            |              | X            |
| NOSAVE                    | X            |              | X            |
| NPRI                      | X            |              | X            |
| OUTPUT                    | X            |              | X            |
| PARLIM                    | X            |              | X            |
| PLCT                      | X            |              | X            |
| PTERM                     | X            |              | X            |
| REGION                    | X            |              | X            |
| SAVE                      | X            |              | X            |

Table 86. Valid environments for the /ASSIGN command and keywords (continued)

| <b>Command / Keywords</b> | <b>DB/DC</b> | <b>DBCTL</b> | <b>DCCTL</b> |
|---------------------------|--------------|--------------|--------------|
| SEGNO                     | X            |              | X            |
| SEGSZ                     | X            |              | X            |
| TRAN                      | X            |              | X            |
| USER                      | X            |              | X            |
| VTAMPOOL                  | X            |              | X            |

## **Syntax**

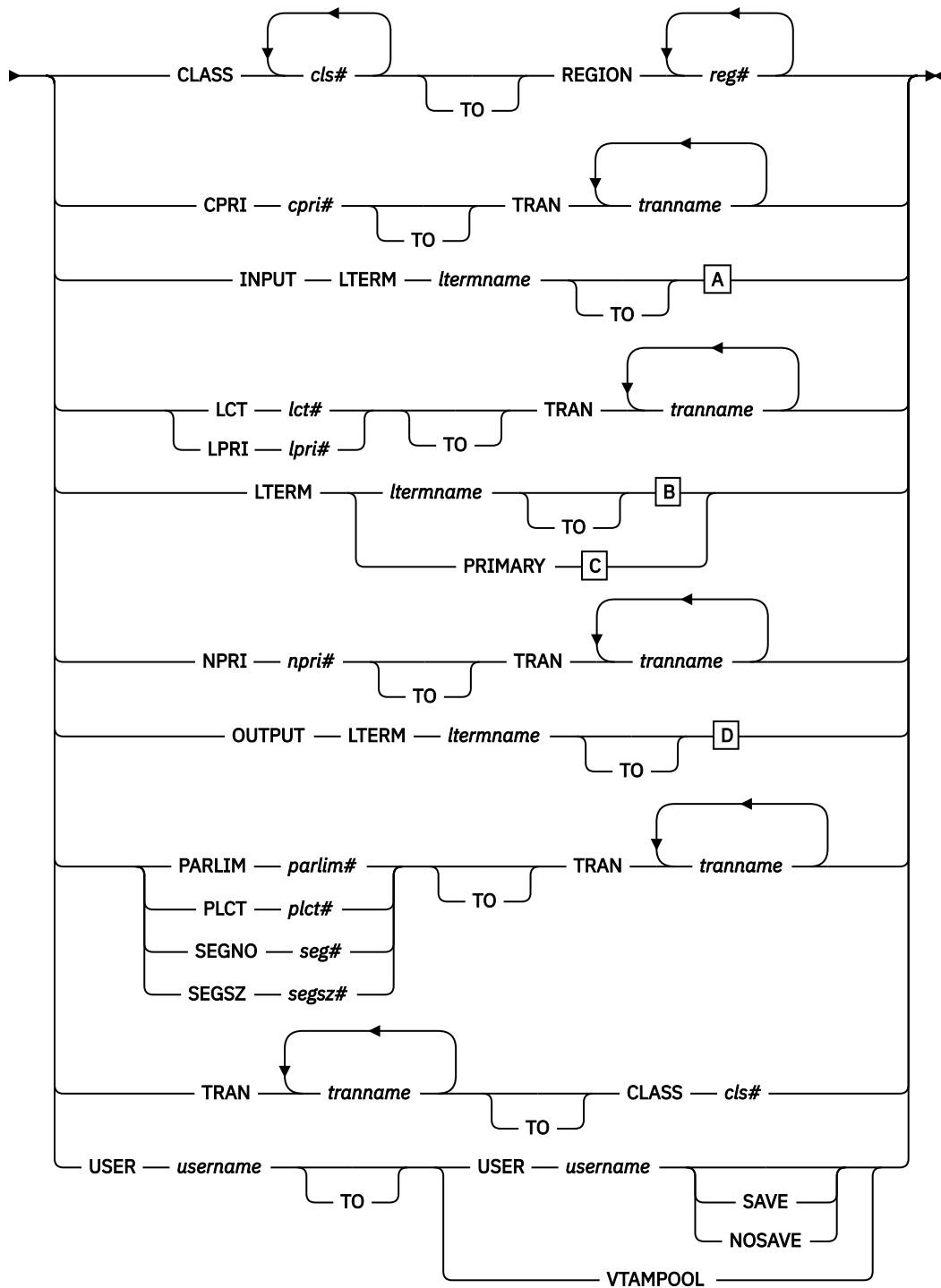
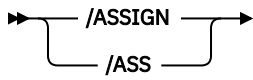

**A**

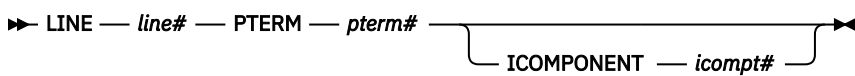

**B**

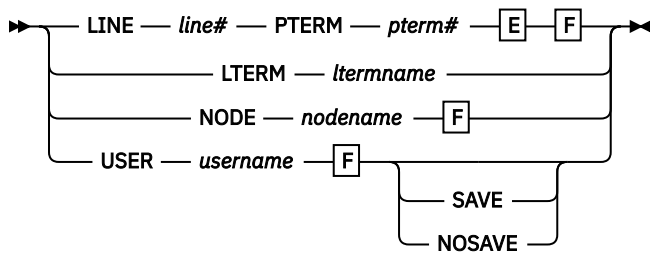

**C**

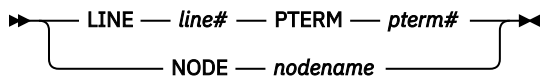

**D**

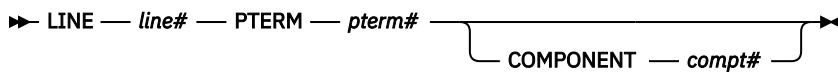

**E**

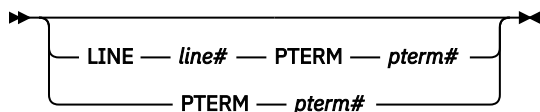

**F**



## Keywords

The following keywords can be specified for the **/ASSIGN** command:

### CLASS

Specifies either the classes of transactions that a message processing region can schedule or the message processing class of a transaction.

The **/ASSIGN CLASS cls# (TO) REGION reg#** command can include up to four class parameters and replaces the class values that existed previously. Valid class parameters are numeric values from 1 to 999.

For static transactions, the CLASS parameter (cls#) is initially set by system definition using the TRANSACT macro statement. For CPI communications driven transactions, the initial value is obtained from the TP profile.

### COMPONENT

Allows output for a logical terminal to be directed to a specific component of a physical terminal. The COMPONENT parameter, which can have values 1, 2, 3 or 4, indicates the terminal component that should receive the output. Parameter values other than 1 are valid for the 3275 and SLU 1 terminals, as well as type 1 and type P secondary logical units. When assigning a COMPONENT value from a terminal with components to a terminal without components, give the compt# a value of 1.

The following table shows the relationships between COMPONENT values and terminals. The first column lists the terminal, the second and third columns list the COMPONENT parameters that can have values of 1, 2, 3, or 4.

*Table 87. Relationships between COMPONENT/ICOMPONENT values and terminals*

| Terminal | 1     | 2/3/4   |
|----------|-------|---------|
| 3275     | Video | Printer |

Table 87. Relationships between COMPONENT/ICOMPONENT values and terminals (continued)

| Terminal       | 1   | 2/3/4   |
|----------------|---|---|
| 3770           | Console/Printer   | Defined in TERMINAL macro on logon descriptor during system definition. |
| SLU 1          | Defined in TERMINAL macro on logon descriptor during system definition. |   |
| SLU P terminal | Defined in TERMINAL macro on logon descriptor during system definition. |   |
| SLU 4          | Defined in TERMINAL macro during system definition.                     |   |

### CPRI

Specifies a new value for the current priority of a transaction. The CPRI keyword is not allowed for BMP transactions, since BMP transactions should always have a priority of 0. The new CPRI value takes effect the next time the transaction is scheduled. Valid CPRI parameters are numeric values from 0 to 14.

### ICOMPONENT

Specifies the input component of a logical terminal to be directed to a specific component of a physical terminal. The ICOMPONENT parameter, which can have values 1, 2, 3, or 4, indicates the terminal component that should receive the input. Parameter values other than 1 are valid for the 3275 and SLU 1 terminals, as well as type 1 and type P secondary logical units. When assigning from a terminal with components to a terminal without components, give icompt# a value of 1. See [Table 87 on page 106](#) for relationships between ICOMPONENT values and terminal components.

### INPUT

Specifies that the input capability of a logical terminal is to be assigned to a given nonswitched physical terminal without affecting the output assignment. More than one physical terminal can be assigned as input for a logical terminal, but the logical terminal used must be the first logical terminal in a "chain."

### LINE

Specifies the non-VTAM devices to which the input or output capabilities (or both) of a logical terminal are to be assigned. The physical terminal must not be on a switched line, in conversational, response, or preset destination modes.

### LCT

Specifies a new value for the limit count of a transaction. The new LCT value takes effect during execution of the transaction. Valid LCT parameters are numeric values from 1 to 65535.

### LPRI

Specifies a new value for the limit priority of a transaction. The LPRI keyword is not allowed for BMP transactions, since BMP transactions should always have a priority of 0. The new LPRI value takes effect the next time the transaction is scheduled. Valid LPRI parameters are numeric values from 0 to 14.

### LTERM

LTERM assigns the input and output capabilities of a local logical terminal to the given nonswitched physical terminal or terminals. The **/ASSIGN LTERM** command does not apply to Multiple Systems Coupling (MSC) remote logical terminals.

- If you specify **/ASSIGN LTERM** with LINE/PTERM selected, the first physical terminal (LINE/PTERM specification) is the input assignment. The second physical terminal (LINE/PTERM specification) is the output assignment. If there is no second physical terminal specification, then the first physical terminal specification is also the output assignment.
- If you specify **/ASSIGN LTERM [TO] NODE**, the node specification is the input and output assignment.

No response is sent to a terminal referenced in an **/ASSIGN** command. The logical terminal must not be an inquiry logical terminal and must not have queuing or dequeuing of messages in progress.

LTERMs created dynamically can be assigned to dynamically created users. Static logical terminals can be assigned to other static terminals. Dynamic logical terminals cannot be assigned to lines, static nodes, dynamic nodes, or static users. Static logical terminals cannot be assigned to dynamic nodes or users. **/ASSIGN** commands that split the logical terminal so that the input LTERM is associated with one node and the output is associated with another node are not allowed for any ACF/VTAM terminals.

**Physical terminal considerations:** The physical terminal named in the command or indirectly referred to by being associated with a logical terminal in the command must not be on a switched line, in conversational, response, or preset destination modes. If a user logical terminal is specified, no logical terminal in the subpool can be currently signed on, and the line and physical terminal for input and output must be the same. If message processing programs are dependent upon a particular LTERM-to-component assignment, this relationship must be maintained by the operator.

MSGDEL processing for an LTERM is based on how the MSGDEL option was defined:

- For static LTERMs defined during system definition as part of the VTAMPOOL for ISC support and for dynamic LTERMs, the MSGDEL options of the users must match when moving LTERMs between the users.
- For all other static LTERMs, the MSGDEL option is defined in the TERMINAL macro for the associated physical terminal.
- If a terminal's MSGDEL capabilities are defined in the TERMINAL macro as MSGDEL=NONIOPCB, assignment of an LTERM can take place only if the LTERM's message queues are empty, except when the LTERM is assigned to a terminal also defined as MSGDEL=NONIOPCB.
- If a terminal's MSGDEL capabilities are defined as MSGDEL=SYSINFO or NOTERM, assignment of an LTERM can take place only if the LTERM's system message queue is empty, except when the LTERM is assigned to a terminal defined as MSGDEL=SYSINFO or NOTERM, or MSGDEL=NONIOPCB.

**Master terminal considerations:** The primary and secondary master terminals cannot be assigned to a user, an input-only or output-only device, a terminal in response mode, an unattended type 1 secondary logical unit terminal, an ISC node, or NTO terminal, or dynamic node. The LINE/PTERM or NODE to which the master terminal is to be assigned must be started and in an operable state. The line and physical terminal for input and output must be the same.

When a 3270 is designated as the master terminal during IMS system definition, two master logical terminals are generated. One, referred to as the primary master terminal, must be assigned to a 3270 display (3275/3276/3278/3279) for all input and output messages. The other, referred to as the secondary master terminal, must be assigned to a 3270 printer (3284/3286/3287/3288/3289) for certain IMS-selected output messages.

To move a single master logical terminal from one physical terminal to another physical terminal (for example, the secondary master from one 3284 to another 3284, or the primary master from one 3277 to another 3277) without moving the other, use the formats of **/ASSIGN LTERM** command with one LINE/PTERM or NODE, and specify the LTERM name of the master terminal.

You can use either of the following commands:

- `/ASSIGN LTERM ltermname (TO) NODE nodename`
- `/ASSIGN LTERM ltermname (TO). LINE line# PTERM pterm#`

**PRIMARY parameter:** The reserved parameter PRIMARY can be used with the LTERM keyword to change both the primary and secondary master terminals assignments to other physical terminals concurrently. The command formats used with the PRIMARY parameter are:

- `/ASSIGN LTERM PRIMARY (TO) LINE line#1 PTERM pterm#1/NODE nodename#1`

This command format assigns both the input and output of the primary master terminal to LINE line#1 PTERM pterm#1, and both the input and output of the secondary master terminal to NODE nodename.

- `/ASSIGN LTERM PRIMARY (TO) (LINE line#1 PTERM pterm#1/NODE nodename1)(LINE line#2 PTERM pterm#2/NODE nodename2)`



This command format assigns the input and output of the primary master terminal to the LINE line#1 PTERM pterm#1/NODE nodename #1 and assigns the input and output of the secondary terminal to LINE line#2 PTERM#2/NODE nodename#2.

These two formats can reassign:

- The 3270 primary and 3270 secondary master terminals to different 3270 physical terminals, where pterm#1 or nodename1 is a 3270 display and pterm#2 or nodename2 is a 3270 printer.
- A non-3270 master terminal to a 3270 display and 3270 printer, where pterm#1 or nodename1 is a 3270 display and pterm#2 or nodename2 is a 3270 printer.

The first LINE/PTERM or NODE specifies the display device to which the primary master logical terminal is to be assigned. The second LINE/PTERM or NODE specifies the printer device to which both the input and output capabilities of the secondary are to be assigned. If only one LINE/PTERM or NODE is specified, then the input and output capabilities of the primary master logical terminal and the secondary master logical terminal are assigned to the same LINE/PTERM or NODE.

**Data considerations:** IMS does not edit data destined for a logical terminal when an **/ASSIGN LTERM** or **/ASSIGN USER** command is executed that affects physical terminal to logical terminal relationships. Ensure that data that is to be sent to a given physical terminal is suitable for transmission to a different physical terminal. If the Message Format Service (MFS) is used and the FMT definition included the second device, the change of physical terminal from one MFS-supported device to another MFS-supported device will produce correct output.

The command format used with the **/ASSIGN LTERM ltermname** command is:

- `/ASSIGN LTERM ltermname [TO] LINE line#1 PTERM pterm#1`

This command format assigns the input and output capabilities of the logical terminal to LINE line#1 PTERM pterm#1. This command is not valid if the LTERM is dynamic.

```
/ASSIGN LTERM ltermname [TO] LINE line#1
PTERM pterm#1 LINE line#2
PTERM pterm#2
```

This command format assigns the input capability of the logical terminal to the first LINE/PTERM pair and assigns the output capability of the logical terminal to the second LINE/PTERM pair. This command is not valid if the LTERM is dynamic.

- `/ASSIGN LTERM ltermname [TO] LINE line#1 PTERM pterm#1 PTERM pterm#2`

This command format assigns the input capability of the logical terminal to LINE line#1 PTERM pterm#1 and assigns the output capability of the logical terminal to the same LINE, line#1, but to a different PTERM, pterm#2. This command is not valid if the LTERM is dynamic.

- `/ASSIGN LTERM ltermname [TO] NODE nodenamez`

This command format assigns the input and output capabilities of the logical terminal to NODE nodename. This command is not valid if the LTERM or NODE is dynamic.

- `/ASSIGN LTERM ltermname1 [TO] LTERM ltermname2`

This command format allows an input chain to be moved to a symbolic location, rather than to a specific line and physical terminal. The [TO] line and terminal are determined by the current assignment of the specified [TO] logical terminal. With this format, the output assignment is not affected. This form of the **/ASSIGN** command is invalid for ISC nodes defined for parallel sessions, and it is not supported for LTERMs associated with VTAM terminals.

- `/ASSIGN LTERM ltermname [TO] USER username`

This command format assigns the logical terminal to the given user. When moving logical terminals between users, the MSGDEL options of the users as defined during system definition or on user descriptor must match. The user related to LTERM ltermname must not be signed on in conversation, in response mode, or in preset mode. For 3600/FINANCE, SLU P, and ISC, the user (username) can remain allocated because of terminal message resynchronization requirements. However, the user cannot be signed on because the associated terminal session must be stopped and idle. The user

can be allocated, but, if allocated, must be associated with a session that is stopped and idle. This command will turn off the DEADQ status for the user associated with LTERM ltermname.

#### **NODE**

Specifies the VTAM terminal to which the input and output capabilities of a logical terminal are to be assigned. The node must not be dynamic, or in conversational, response, or preset destination modes. If a session with a VTAM terminal is terminated after a message is sent but before the response has been received, message resynchronization is necessary for this terminal. The output message for which no response was received must remain associated with this terminal until message resynchronization determines when the terminal received the message. If you use the /ASSIGN command to move the message to a different terminal, message resynchronization is no longer possible.

#### **NOSAVE**

Indicates that the assignment changes specified by the /ASSIGN command are lost when control blocks are deleted by the system when they are no longer needed. Omitting SAVE and NOSAVE causes the system-wide default to be used, as specified by the ASSNCHANGE parameter in the DFSDCxxx PROCLIB member.

#### **NPRI**

Specifies a new value for the normal priority of a transaction. The NPRI keyword is not allowed for BMP transactions, because BMP transactions should always have a priority of 0. The new NPRI value takes effect the next time the transaction is scheduled. Valid NPRI parameters are numeric values from 0 to 14.

#### **OUTPUT**

Specifies that the output capability of a logical terminal is to be assigned to a given nonswitched physical terminal, without affecting the input assignment. OUTPUT is invalid for ISC nodes defined for parallel sessions.

#### **PARLIM**

Specifies a new value for the parallel processing limit count of a transaction. parl# is the maximum number of messages that can currently be queued, but not yet processed, by each active message region currently scheduled for this transaction. An additional region will be scheduled whenever the transaction queue count (for shared-queues environments, the successful consecutive GU count is used instead of the queue count) exceeds the PARLIM value multiplied by the number of regions currently scheduled for this transaction. Valid PARLIM parameters are numeric values from 0 to 32767 and 65535, where 65535 disables transaction load balancing.

A PARLIM of 65535 is the only valid value allowed for a transaction that is shown as eligible for load balancing but has an application program defined as SCHDTYPE=SERIAL. For example, if you dynamically change a parallel transaction to a serial transaction through online change, the only valid value for PARLIM is 65535.

**/ASSIGN PARLIM** is not valid for CPI Communications driven transactions.

**Note:** In a shared-queues environment, the PARLIM value behaves differently than it does in a non-shared-queues environment. In a non-shared-queues environment, the queue depth (the number of messages that are currently enqueued) for the transaction is used as the value that is compared with the PARLIM value to determine when to schedule another region. IMS responds to a growing queue of input transactions by scheduling more regions as the queue grows.

In a shared-queues environment, each individual IMS does not know the depth of the queue, because the queue is in the shared-queues coupling facility structure that is managed by Common Queue Server (CQS). The transaction queue might be added to by many different IMS systems. IMS is notified only when the first message is put in a queue (that is, when the queue becomes *not empty*). IMS is not notified for every subsequent message that is placed on the queue after that first message. In a shared-queues environment, the PARLIM comparison is done against a counter that each IMS keeps of the number of successful consecutive GU calls for the transaction by that IMS, rather than queue depth. IMS schedules more regions when it consistently gets messages from CQS when it asks for them. Thus, in a shared-queues environment, IMS infers the depth of

the queue of messages based on processing activity, but it does not know the actual depth of the queue.

A PARLIM value of 0 in a shared-queues environment is the most responsive setting. PARLIM(0) ensures that message regions are scheduled until all messages are processed from the transaction queue, or until the maximum region value (MAXRGN) limit is reached. PARLIM(0) might, however, result in many unnecessary schedules (or *false schedules*). A false schedule occurs when a message region is scheduled and finds no more messages on the queue. This occurs particularly with PARLIM(0) because after each successful get unique (GU), IMS must always schedule an additional region to try to read the queue to see if there are more messages. This process continues for each successful GU until the queue becomes empty, at which time the successive GU count is reset to 0. This is a consequence of IMS not knowing how many messages are queued on the transaction queue.

Setting the PARLIM to a value greater than 0 can reduce the number of false schedules, because IMS then schedules a new message region only after a number of messages have been obtained consecutively without the queue becoming empty. Setting the PARLIM to a value of 2 or greater is useful for reducing false schedules for transactions that are low-volume and that run relatively quickly (such that the queue depth is typically 1), because it avoids scheduling a second region until the first region has obtained at least two messages in a row. However, be aware that while a PARLIM value greater than 0 can reduce unnecessary schedules, it is also less responsive. If a transaction is long running, or if its processing is delayed (for example, because of locking contention), the consecutive GU count does not change while the transaction is executing, and no additional message regions are scheduled. This can result in delayed processing of other messages for this same transaction until a currently-scheduled message completes. This delay can occur even if message regions are available to process the transaction.

#### **PLCT**

Specifies a new value for the processing limit count of a transaction. The PLCT is the number of messages of this transaction code that a program can process in a single scheduling. The new PLCT values take effect the next time the transaction is scheduled. Valid PLCT parameters are numeric values from 0 to 65535.

`/ASSIGN PLCT` is not valid for CPI Communications driven transaction programs.

#### **PTERM**

Specifies the non-VTAM device to which the input or output capabilities (or both) of a logical terminal are to be assigned.

#### **REGION**

Specifies the message processing region being assigned new classes of transactions that the region can schedule.

#### **SAVE**

Prevents deletion of user and LTERM control blocks across session and IMS restarts. Control blocks will be retained until the NOSAVE keyword is used with the `/ASSIGN` command. Omitting SAVE and NOSAVE causes the system-wide default to be used, as specified by the ASSNCHANGE parameter in the DFSDCxxx PROCLIB member.

#### **SEGNO**

Creates or changes the limit on the number of application program output segments allowed in message queues for each GU call. Segment limits will be established by transaction code, thereby allowing specification of more than one value for each application program. The new SEGNO value takes effect during execution of the transaction. Valid SEGNO parameters are numeric values from 0 to 65535.

The `/ASSIGN SEGNO` command is not valid for CPI Communications driven transaction programs.

#### **SEGSZ**

Creates or changes the limit on the size of application program output segments allowed in message queues for each GU call. The new SEGSZ value takes effect during execution of the transaction. Valid SEGSZ parameters are numeric values from 0 to 65535.

The `/ASSIGN SEGSZ` command is not valid for CPI Communications driven transaction programs.

## TRAN

Specifies the transaction being assigned to a message processing class or being assigned a value. The new class takes effect the next time the transaction is scheduled.

## USER

Assigns logical terminals to ISC half-sessions or to dynamic users. When moving logical terminals between users, the MSGDEL options of the users must match. The MSGDEL option for the static ISC users is defined in the SUBPOOL macro during system definition. The MSGDEL option for dynamic terminals is defined in the OPTIONS keyword of the ETO USER descriptor. /ASSIGN USER to VTAMPOOL is not valid if USER is not ISC.

/ASSIGN LTERM ltermname (TO) USER username assigns the logical terminal to another USER. The user associated with LTERM ltermname must not be allocated. The USER username can be allocated, but it must be associated with a session that is stopped and idle, if allocated.

**Note:** Assigning an LTERM is not a permanent action. When the destination structure is deleted (for example, with **/SIGN OFF**) IMS discards information about the assignment. When the original dynamic user who owned that dynamic LTERM signs on again or gets a message switch, the dynamic LTERM is recreated for the original dynamic user.

If SAVE is specified, the dynamic user is not deleted unless another **/ASSIGN** command with the NOSAVE keyword is issued.

/ASSIGN USER username1 (TO) USER username2 assigns a string of logical terminals to another USER. The first user (username1) in the command must contain at least one logical terminal and must not be signed on, in conversation, in response mode, or in preset mode. For 3600/FINANCE, SLU P, and ISC, the second user (username2) can remain allocated due to terminal message resynchronization requirements. However, the user cannot be signed on and associated terminal sessions must be stopped and idle. This command turns off the DEADQ status for USER username1.

In addition to the ISC rules and restrictions, following dynamic terminal restrictions also apply. The /ASSIGN USER to USER and /ASSIGN LTERM to USER commands are rejected if the source or destination dynamic user is in conversation mode, response mode, or preset mode. The second USER can be allocated, but it must be associated with a session that is stopped and idle, if allocated.

When existing dynamic LTERMs or dynamic users are assigned to a destination user that does not exist, the destination user is created unless it is rejected by the DFSINSX0 user exit.

## VTAMPOOL

Is valid only for VTAM ISC sessions. It is used to force a cold start of an ISC session that cannot perform a successful restart.

**/ASSIGN VTAMPOOL** deallocates an entire string of logical terminals allocated to a given USER. The user must not be signed on, in conversation mode, response mode, or preset mode, and the terminal must be stopped and idle. This command is valid for static and dynamic ISC users.

## Usage notes

Most changes made by the **/ASSIGN** command remain in effect until changed with another **/ASSIGN** command, or an IMS cold start (/NRESTART CHECKPOINT 0) is performed.

This command can be issued to an IMSplex using the Batch SPOC utility.

When dynamic LTERMs are assigned to dynamic users with the **/ASSIGN LTERM TO USER** command, or dynamic users are assigned to dynamic users with the **/ASSIGN USER TO USER** command, changes remain in effect only if the following conditions are true:

- The SAVE keyword is used.
- SAVE and NOSAVE keywords are omitted, but ASSNCHANGE=SAVE is specified in the DFSDCxxx PROCLIB member.

Otherwise, changes are lost when the destination user is deleted during user sign-off or IMS checkpoint. Changes that affect regions, such as CLASS, are only in effect until the region terminates.

**Recommendation:** Use the **/ASSIGN** command consistently on all IMS subsystems that are members of a VTAM generic resources group or share IMS queues. For example, assign an LTERM to a specific node for all IMS subsystems; assigning one LTERM to different nodes on different IMS subsystems could cause unpredictable results.

The **/ASSIGN** command is mirrored on an XRF alternate environment unless the assignment involves the primary or secondary master terminal, or the assignment of a CLASS to a REGION.

**/ASSIGN** commands attempting to assign LTERMs or users between static and dynamic terminals receive a unique error message. An error message is issued if **/ASSIGN** attempts any of the following

- To assign a dynamic LTERM to a static USER.
- To assign a static USER to a dynamic USER.
- To assign a dynamic USER to a static USER.
- To assign a dynamic LTERM to a LINE or NODE.
- To assign a static LTERM to a dynamic USER.

**Restriction:** You cannot use the **/ASSIGN** command to assign a user structure to a node that does not exist. Use the **/OPN NODE nodename USER useiname** command instead.

## **/ASSIGN in an IMSplex**

In an IMSplex, the **/ASSIGN LTERM** and **/ASSIGN USER** commands alter the relationships between one or more logical terminals and a physical terminal or user.

### **Static terminals**

For static terminals in an IMSplex, the control blocks should exist in all the IMS systems where a user could possibly log on to that terminal. If **/ASSIGN LTERM TO NODE** is specified in an IMSplex, it should be issued from the Single Point Of Control (SPOC) application. If ROUTE is specified, it should be specified as ROUTE(\*). Otherwise, the **/ASSIGN** command may not be processed consistently across the IMSplex and could cause unpredictable results. If one of the **/ASSIGN** commands fails, that IMS will send back a completion code to the Operations Manager (OM) indicating failure. It will be up to the IMS installation to correct that problem.

**/ASSIGN LTERM TO NODE** assigns the input and output capabilities of a logical terminal to a static VTAM node. The logical terminal may not be in conversational, response, or preset destination mode. The source and destination terminals do not need to be stopped or logged off.

If global resource information is not kept in the Resource Manager (RM) and the node exists locally, this command applies locally. If global resource information is kept in RM, this command applies globally, if the control blocks exist in RM. However, the assignment changes are not considered significant, and if the resource is deleted, the assignment changes are deleted as well. An LTERM that exists in the RM could be deleted if the static node to which it is assigned does not exist in the RM. If NODEA and LTERMA exist in the RM because the node is in exclusive mode, but static NODEB is not in RM, an **/ASSIGN LTERM LTERMA NODE NODEB** command would result in LTERMA being deleted in RM.

The IMS where the LTERM and node are active, or the command master if the resources are not active, will make the changes in the RM. In this case, "active" includes the case where the terminal is logged off, but has an RM affinity to a particular IMS. For **/ASSIGN LTERM TO NODE**, the LTERM and node might not be active in different IMS systems.

When the log on of a static node attempts to write its LTERM names to the RM, but one or more of the LTERM names are already in use, IMS will reject the log on. This error should occur only if there are inconsistent definitions, or there have been inconsistent **/ASSIGN** commands issued in the IMSplex.

## Dynamic terminals

**/ASSIGN LTERM TO USER** assigns the input and output capabilities of an ETO logical terminal to an ETO user or a static ISC logical terminal to a static ISC subpool. The logical terminal may not be in conversational, response, or preset destination mode. The source user associated with the ETO LTERM might not be signed on. The destination ETO user does not have to be stopped. If global resource information is not kept in RM and the user exists locally, this command applies locally. If global resource information is kept in RM, this command applies globally (if the control blocks exist in RM). However, the assignment changes are not considered significant, and if the resource is deleted, the assignment changes are deleted as well. The IMS where the LTERM and node are active, or the command master if the resources are not active, will make the changes in the RM.

Use **/ASSIGN LTERM TO USER** with the **SAVE** keyword in an RM environment, to cause the assignment to persist and to apply the change to future IMS systems that join the IMSplex. The **SAVE** keyword is valid only for dynamic terminals, so this persistence function is not available for static terminals. Use **/ASSIGN LTERM TO USER** with the **NOSAVE** keyword in an RM environment, to stop applying the change to future IMS systems that join the IMSplex.

**/ASSIGN USER TO USER** assigns all the logical terminals associated with the source user to the destination user. The destination user, if dynamic, does not have to be stopped. If global resource information is not kept in RM and the user exists locally, this command applies locally. If global resource information is kept in RM, this command applies globally. Use **/ASSIGN USER TO USER** with the **SAVE** keyword in an RM environment to cause the assignment to persist and to apply the change to future IMS systems that join the IMSplex. The **SAVE** keyword is valid only for dynamic terminals, so this persistence function is not available for static terminals. Use **/ASSIGN USER TO USER** with the **NOSAVE** keyword in an RM environment to stop applying the change to future IMS systems that join the IMSplex.

The **/ASSIGN** command is allowed when the destination user does not exist. However, when resource information is being kept in RM, unless the **SAVE** keyword is used, this command will not be allowed. Assignments are not considered significant without the **SAVE** keyword, and if the user does not already exist because of some other significant status, there is no reason to create the user.

IMS will dynamically create the source LTERM or user (if it does not exist) to enable the **/ASSIGN** command. If the destination also does not exist, the **SAVE** keyword must be specified on the **/ASSIGN** command. Otherwise, the **SAVE** keyword is optional.

### Non-VTAM devices and VTAM

IMS supports the assignment of an LTERM between non-VTAM devices and VTAM terminals. However, IMS will not save any non-VTAM status. For example, if an LTERM is assigned from VTAM to a non-VTAM device, the LTERM will be deleted from the RM, and any status that might have been associated with that LTERM will no longer be recoverable.

## Equivalent IMS type-2 commands

The following table shows variations of the **/ASSIGN** command and the IMS type-2 commands that perform similar functions.

Table 88. Type-2 equivalents for the **/ASSIGN** command

| Task   | <b>/ASSIGN</b> command  | Similar IMS type-2 command  |
|--|---|---|
| Changes the value for the limit count of a transaction.    | <b>/ASSIGN LCT</b> <i>new_lmct_number</i> TO<br>TRAN <i>tranname</i>  | UPDATE TRAN NAME ( <i>tranname</i> )<br>SET(LCT( <i>new_limit_count</i> ))    |
| Changes the value for the limit priority of a transaction. | <b>/ASSIGN LPRI</b> <i>new_lpri_number</i> TO<br>TRAN <i>tranname</i> | UPDATE TRAN NAME( <i>tranname</i> )<br>SET(LPRI( <i>new_limit_priority</i> )) |

Table 88. Type-2 equivalents for the /ASSIGN command (continued)

| Task  | /ASSIGN command   | Similar IMS type-2 command   |
|---|---|--|
| Changes the value for the normal priority of a transaction.   | /ASSIGN NPRI <i>new_npri_number</i> TO TRAN <i>tranname</i>     | UPDATE TRAN NAME( <i>tranname</i> ) SET(NPRI( <i>new_normal_priority</i> ))  |
| Changes the value for the parallel processing limit count of a transaction.   | /ASSIGN PARLIM <i>new_parlim_number</i> TO TRAN <i>tranname</i> | UPDATE TRAN NAME( <i>tranname</i> ) SET(PARLIM( <i>new_parallel_limit</i> )) |
| Changes the value for the processing limit count of a transaction.  | /ASSIGN PLCT <i>new_plmct_number</i> TO TRAN <i>tranname</i>    | UPDATE TRAN NAME( <i>tranname</i> ) SET(PLCT( <i>new_processing_limit</i> )) |
| Changes the limit on the number of application program output segments allowed in message queues for each GU call.          | /ASSIGN SEGNO <i>new_segno_number</i> TO TRAN <i>tranname</i>   | UPDATE TRAN NAME( <i>tranname</i> ) SET(SEGNO( <i>new_segment_number</i> ))  |
| Creates or changes the limit on the size of application program output segments allowed in message queues for each GU call. | /ASSIGN SEGSZ <i>new_segsize_number</i> TO TRAN <i>tranname</i> | UPDATE TRAN NAME( <i>tranname</i> ) SET(SEGSZ( <i>new_segment_size</i> ))    |
| Changes the class number of a transaction.  | /ASSIGN TRAN <i>tranname</i> TO CLS <i>new_class_number</i>     | UPDATE TRAN NAME( <i>tranname</i> ) SET(CLASS( <i>new_class_number</i> ))    |

### Examples

The following are examples of the /ASSIGN command:

#### Example 1 for /ASSIGN command

Entry ET:

```
/ASSIGN CLASS 5 TO REGION 3
```

Response ET:

```
DFS058I ASSIGN COMMAND COMPLETED
```

Explanation: Class 5 is assigned to region 3. Class 5 transactions are scheduled into region 3. This command resets any previous class assignments to this region.

#### Example 2 for /ASSIGN command

Entry ET:

```
/ASSIGN CLASS 4 6 2A TO REGION 5
```

Response ET:

```
DFS058I ASSIGN COMMAND COMPLETED EXCEPT CLASS 2A
```

Explanation: The requested assignment is complete except for 2A, which is an invalid class number.

#### Example 3 for /ASSIGN command

Entry ET:

```
/ASSIGN CPRI 8 TO TRAN PIT, SEED
```

Response ET:

```
DFS058I  ASSIGN COMMAND COMPLETED
```

Explanation: A current priority of 8 is set for the transactions named PIT and SEED.

**Example 4 for /ASSIGN command**

Entry ET:

```
/ASSIGN INPUT LTERM JONES TO LINE 4 PTERM 3
```

Response ET:

```
DFS058I  ASSIGN COMMAND COMPLETED
```

Explanation: Logical terminal JONES is assigned to LINE 4 PTERM 3 for input identification and security. It associates the chain of logical terminals, of which LTERM JONES will be chained in first, with LINE 4 PTERM 3 for input. LTERM JONES must not be in the interior of an input chain (no other logical terminal can point to it). A physical terminal can point (for input only) to the first logical terminal of any chain. The output physical terminal for LTERM JONES is not changed.

**Example 5 for /ASSIGN command**

Entry ET:

```
/ASSIGN LTERM APPLE TO LINE 5 PTERM 1
```

Response ET:

```
DFS058I  ASSIGN COMMAND COMPLETED
```

Explanation: Logical terminal APPLE has both its input and output capabilities assigned to LINE 5 PTERM 1. The components present on LINE 5 PTERM 1 must be compatible with the physical terminal previously related to logical terminal APPLE.

**Example 6 for /ASSIGN command**

Entry ET:

```
/ASSIGN LTERM APPLE TO NODE JONES
```

Response ET:

```
DFS058I  ASSIGN COMMAND COMPLETED
```

Explanation: Logical terminal APPLE has both its input and output capabilities assigned to node JONES. The components present on node JONES must be compatible with the physical terminal previously related to logical terminal APPLE.

**Example 7 for /ASSIGN command**

Entry ET:

```
/ASSIGN LTERM SMITH TO LINE 4 PTERM 6 PTERM 7 COMPONENT 2
```

Response ET:

```
DFS058I  ASSIGN COMMAND COMPLETED
```

Explanation: Logical terminal SMITH is assigned to LINE 4 PTERM 6 for input and LINE 4 PTERM 7 for output. Output for LINE 4 PTERM 7 is directed to COMPONENT 2.

**Example 8 for /ASSIGN command**

Entry ET:



```
/ASSIGN LTERM X TO LINE 5 PTERM 7 PTERM 6 COMPONENT 4  
ICOMPONENT 3
```

Response ET:

```
DFS058I ASSIGN COMMAND COMPLETED
```

Explanation: Logical terminal X is assigned to LINE 5 PTERM 7 for input and to LINE 5 PTERM 6 for output. Input is only received from input component 3, while output is directed to component 4.

**Example 9 for /ASSIGN command**

Entry ET:

```
/ASSIGN LTERM JONES TO LINE 4 PTERM 6 LINE 9 PTERM 1
```

Response ET:

```
DFS058I ASSIGN COMMAND COMPLETED
```

Explanation: Logical terminal JONES is assigned to LINE 4 PTERM 6 for input capability and LINE 9 PTERM 1 for output capability. The component assignment is unaffected.

**Example 10 for /ASSIGN command**

Entry ET:

```
/ASSIGN LTERM SMITH NODE JONES
```

Response ET:

```
DFS058I ASSIGN COMMAND COMPLETED
```

Explanation: Logical terminal SMITH is assigned to node JONES for both input and output.

**Example 11 for /ASSIGN command**

Entry ET:

```
/ASSIGN LTERM BROWN TO LTERM WHITE
```

Response ET:

```
DFS058I ASSIGN COMMAND COMPLETED
```

Explanation: Logical terminal BROWN is removed from its present input chain (if one exists) of logical terminals and added to the end of the input chain (if one exists) of logical terminal WHITE. The output physical terminal for LTERM BROWN is not changed.

**Example 12 for /ASSIGN command**

Entry ET:

```
/ASSIGN LTERM LAX USER ILL ICOMPONENT 1 COMPONENT 2
```

Response ET:

```
DFS058I ASSIGN COMMAND COMPLETED
```

Explanation: Logical terminal LAX is reassigned from its existing user to the user ILL. The user associated with LAX cannot be allocated to an active session.

**Example 13 for /ASSIGN command**

Entry ET:

```
/ASSIGN LTERM PRIMARY TO LINE 4 PTERM 3
```

Response ET:

```
DFS058I ASSIGN COMMAND COMPLETED
```

Explanation: PTERM 3 on LINE 4 becomes the master terminal. PTERM 3 must be a 3270 display.

**Example 14 for /ASSIGN command**

Entry ET:

```
/ASSIGN LTERM PRIMARY TO NODE BOSS
```

Response ET:

```
DFS058I ASSIGN COMMAND COMPLETED
```

Explanation: The node, BOSS, becomes the primary master terminal and the secondary master terminal.

**Example 15 for /ASSIGN command**

Entry ET:

```
/ASSIGN LTERM PRIMARY TO LINE 1 PTERM 2 LINE 2 PTERM 4
```

Response ET:

```
DFS058I ASSIGN COMMAND COMPLETED
```

Explanation: PTERM 2 on LINE 1 becomes the primary master terminal and PTERM 4 on LINE 2 becomes the secondary master terminal. PTERM 2 is a 3270 display station and PTERM 4 is a 3270 printer.

**Example 16 for /ASSIGN command**

Entry ET:

```
/ASSIGN SEGNO 50 TO TRAN APPLE
```

Response ET:

```
DFS058I ASSIGN COMMAND COMPLETED
```

Explanation: A limit of 50 output segments is set for the transaction APPLE.

**Example 17 for /ASSIGN command**

Entry ET:

```
/ASSIGN SEGSZ 1000 TO TRAN APPLE
```

Response ET:

```
DFS058I ASSIGN COMMAND COMPLETED
```

Explanation: A maximum size of 1000 bytes is set for any one output segment of transaction APPLE.

**Example 18 for /ASSIGN command**

Entry ET:

```
/ASSIGN USER ILL TO USER CAL
```

Response ET:

```
DFS058I ASSIGN COMMAND COMPLETED
```

Explanation: All the logical terminals of user ILL are appended to the existing LTERM string of user CAL. Use of this form of the **/ASSIGN** command leaves ILL with no LTERMs and therefore unavailable for allocation to a session. Both user ILL and CAL cannot be allocated to a session.

**Example 19 for /ASSIGN command**

Entry ET:

```
/ASSIGN USER CAL TO VTAMPOOL
```

Response ET:

```
DFS058I  ASSIGN COMMAND COMPLETED
```

Explanation: The entire allocated LTERM string defined for user CAL is reassigned to the VTAM pool. The node to which user CAL is allocated must not be in session and must be stopped and idle. User CAL is then available for allocation to any ISC session.

**Example 20 for /ASSIGN command**

Entry ET:

```
/ASSIGN TRAN APPLE TO CLASS 5
```

Response ET:

```
DFS058I  ASSIGN COMMAND COMPLETED
```

Explanation: The transaction named APPLE is assigned to class 5.

**Related concepts**

[CPI Communications driven application programs \(Communications and Connections\)](#)

**Related reference**

[UPDATE TRAN command \(Commands\)](#)



---

## Chapter 10. /BROADCAST command

The **/BROADCAST** command is a multisegment command used to send a message to terminals in one or more IMS systems.

Subsections:

- [“Environment” on page 121](#)
- [“Syntax” on page 121](#)
- [“Keywords” on page 122](#)
- [“Usage notes” on page 123](#)
- [“Examples” on page 124](#)

### Environment

The following table lists the environments (DB/DC, DBCTL, and DCCTL) in which you can use the command and keywords.

*Table 89. Valid environments for the /BROADCAST command and keywords*

| <b>Command / Keywords</b> | <b>DB/DC</b> | <b>DBCTL</b> | <b>DCCTL</b> |
|---------------------------|--------------|--------------|--------------|
| <b>/BROADCAST</b>         | X            |              | X            |
| ACT                       | X            |              | X            |
| LINE                      | X            |              | X            |
| LTERM                     | X            |              | X            |
| MASTER                    | X            |              | X            |
| MSNAME                    | X            |              | X            |
| NODE                      | X            |              | X            |
| PTERM                     | X            |              | X            |
| SYSID                     | X            |              | X            |
| USER                      | X            |              | X            |

### Syntax

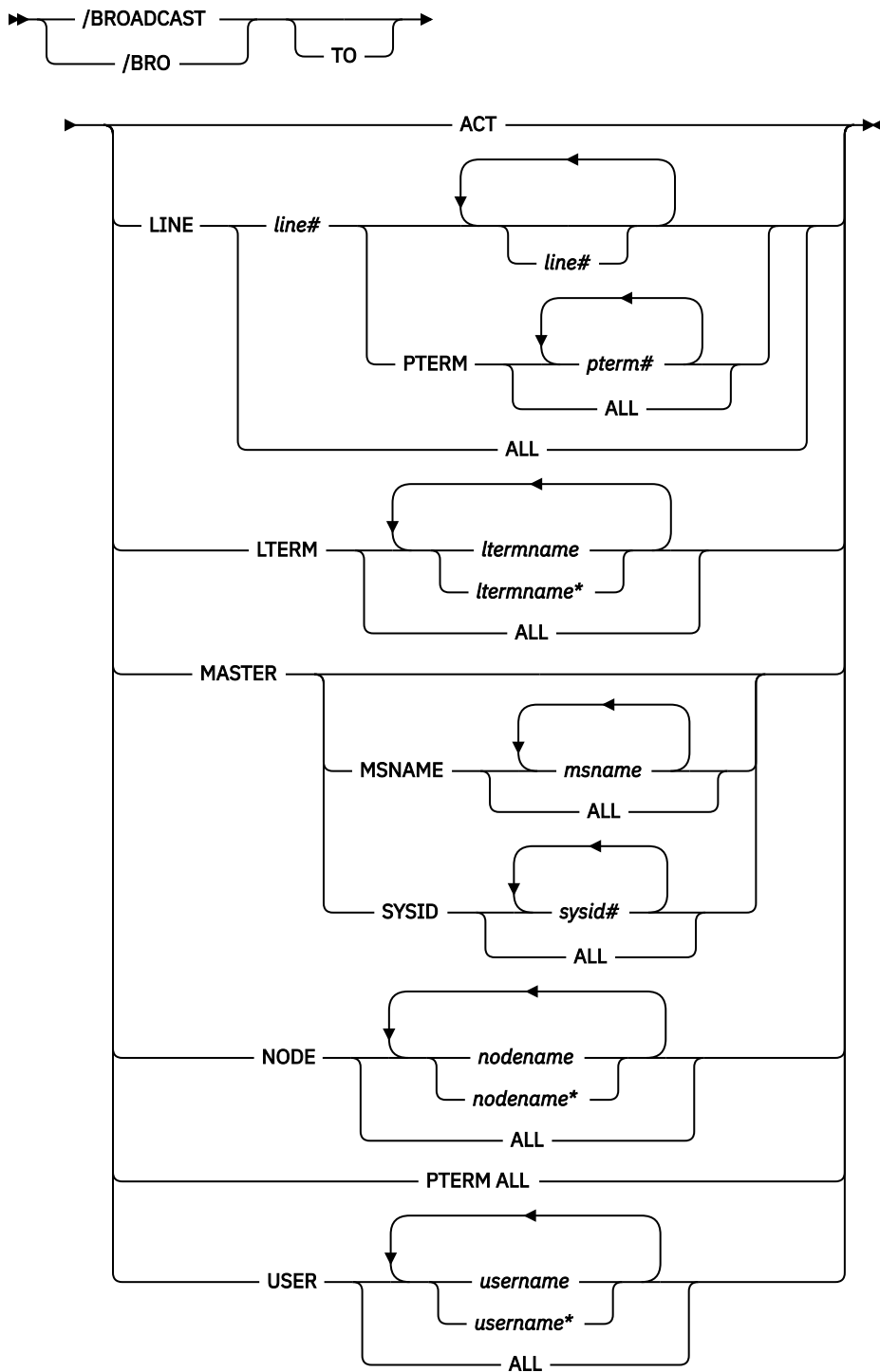

## Keywords

The following keywords can be specified for the `/BROADCAST` command:

### ACT

Specifies that the supplied message is queued to the first LTERM allocated to each active node.

When operating on a dynamic terminal, the `/BROADCAST ACT` command only succeeds if a signed on user exists. A signed on user must exist, otherwise there is no destination to which to send the message.

**LINE**

Specifies that a message is to be sent to all terminals associated with the specified line. PTERM specifies that the message is to be sent to specific terminals on the associated line.

**LTERM**

Specifies that a message is queued to each named LTERM in the local system or any remote system. The remote logical terminal must be defined in the input system.

Where a LTERM does not exist, IMS attempts to create the LTERM and associated user structure if ETO is active. LTERM parameters can be generic, where the generic parameter specifies logical terminals that already exist.

When **/BROADCAST LTERM ALL** is specified, one copy of the message is queued for each logical terminal in the local system. In a multiple systems configuration, the message is not sent to remote systems when the ALL parameter is used. When more than one logical terminal is assigned to a physical terminal for output purposes, multiple copies of the message will result.

When the LTERM keyword specifies a logical terminal assigned to the VTAM pool, broadcast messages are queued for the first logical terminal in a subpool.

**MASTER**

Specifies that a message is to be sent to the IMS master terminal and to any specified secondary master terminal. Keywords SYSID and MSNAME can be used to further qualify the reserved parameter MASTER.

**MSNAME**

Specifies the logical link path in a multiple systems configuration.

**NODE**

Specifies that the supplied message is queued to the first output LTERM allocated to a terminal. If a terminal has no signed on user, no message can be queued. NODE parameters can be generic, where the generic parameter specifies nodes that already exist.

When operating on a dynamic terminal, the **/BROADCAST NODE** command only succeeds if a signed on user exists. A signed on user must exist, otherwise there is no destination to which to send the message.

**PTERM**

Specifies the physical terminal to which a message is to be sent.

**SYSID**

Specifies the system identification of a system in a multiple system configuration.

**USER**

Specifies that the supplied message is queued to the first LTERM associated with the dynamic user. The USER parameter can be generic. The **/BROADCAST USER** command applies only to existing dynamic users.

In an IMSplex, **/BROADCAST USER** queues the supplied message to the first LTERM associated with a dynamic user, if the user is signed on locally. **/BROADCAST USER** cannot be used to queue a message to an LTERM associated with a user signed on to another IMS in the IMSplex, or not signed on at all.

**Usage notes**

For **/BROADCAST** commands entered by the master terminal operator, the multisegment input from this command is combined into 79-character segments for output transmission. The first input segment contains only the broadcast destination. The second and subsequent input segments must contain the data to be broadcast. Messages that are broadcast are sent even if the line, terminal, or both, are stopped at the time the broadcast is issued.

This command can be issued to an IMSplex using the Batch SPOC utility.

All **/BROADCAST** formats require an EOM indication to denote end-of-message; an EOS indication must be included for all segments that precede the last segment.

**Requirement:** When the **/BROADCAST** command is issued from an MCS/E-MCS console, OM API, or an AOI application, a period must appear as a delimiter between the command and the message text.

Unlike message switches, broadcast messages are sent to a terminal even when the terminal, associated line, or both, are not available (stopped, process stopped, or locked). However, broadcast messages are never sent to terminals if the MSGDEL parameter of the TERMINAL macro is specified MSGDEL=NONIOPCB.

Broadcast messages are always queued for logical terminals. When the ACTIVE, LINE, NODE, PTERM, or USER keywords are used, IMS queues the message for the first logical terminal found that is associated for output purposes with the specified line or physical terminal.

### Examples

The following are examples of the **/BROADCAST** command:

#### **Example 1 for /BROADCAST command**

Entry ET:

```
/BROADCAST ACTIVE (EOS)
SYSTEM WILL BE SHUTDOWN FOR PM (EOS)
IN 5 MINUTES (EOM)
```

Response ET:

```
DFS058I BROADCAST COMMAND COMPLETED
```

Response RT:

```
SYSTEM WILL BE SHUTDOWN FOR PM IN 5 MINUTES
```

Explanation: The entered message is transmitted to all active terminals.

#### **Example 2 for /BROADCAST command**

Entry ET:

```
/BROADCAST TO LTERM APPLE, TREE (EOS)
DON'T USE TRANSACTION GREENTRE UNTIL FURTHER (EOS)
NOTICE. (EOM)
```

Response ET:

```
DFS058I BROADCAST COMMAND COMPLETED
```

Response RT:

```
DON'T USE TRANSACTION GREENTRE UNTIL FURTHER
NOTICE.
```

Explanation: The entered message is transmitted to the logical terminals named APPLE and TREE.

#### **Example 3 for /BROADCAST command**

Entry ET:

```
/BROADCAST TO LINE ALL (EOS)
SYSTEM WILL SHUTDOWN AT 5PM (EOM)
```

Response ET:

```
DFS058I BROADCAST COMMAND COMPLETED
```

Response RT:



```
SYSTEM WILL SHUTDOWN AT 5PM
```

Explanation: The entered message is transmitted to all physical terminals.

**Example 4 for /BROADCAST command**

Entry ET:

```
/BROADCAST TO LINE 13 PTERM ALL (EOS)  
EXPECT DEMO YOUR LINE AT 9PM (EOM)
```

Response ET:

```
DFS058I BROADCAST COMMAND COMPLETED
```

Response RT:

```
EXPECT DEMO YOUR LINE AT 9PM
```

Explanation: The entered message is transmitted to all physical terminals on line 13.

**Example 5 for /BROADCAST command**

Entry ET:

```
/BROADCAST MASTER SYSID 2 (EOS)  
SYSTEM WILL SHUTDOWN AT 5:00 PM (EOM)
```

Response ET:

```
DFS058I BROADCAST COMMAND COMPLETED
```

Response RT:

```
SYSTEM WILL SHUTDOWN AT 5:00 PM
```

Explanation: The message is transmitted to the master terminal of the system specified by the SYSID 2.

**Example 6 for /BROADCAST command**

Entry ET:

```
/BROADCAST MASTER MSNAME BOSTON, CHICAGO (EOS)  
SYSTEM WILL SHUTDOWN AT 5:00 PM (EOM)
```

Response ET:

```
DFS058I BROADCAST COMMAND COMPLETED
```

Response RT:

```
SYSTEM WILL SHUTDOWN AT 5:00 PM
```

Explanation: The message is transmitted to the master terminals. of the remote systems specified by the MSNAMEs BOSTON and CHICAGO.

**Example 7 for /BROADCAST command**

Remote Terminal entry:

```
/FORMAT DFSM04  
/BRO LTERM WTOR (eos)  
this is segment 1 (eos)  
this is segment 2 (eos)  
this is segment 3 (eom)
```

Response ET:

```
DFS058I  BROADCAST COMMAND COMPLETED
```

Response RT:

```
THIS IS SEGMENT 1  
THIS IS SEGMENT 2  
THIS IS SEGMENT 3
```

Explanation: The remote terminal is first formatted by the **/FORMAT** command, where default format DFSMO4 supports the input of four segments. This is followed by **/BROADCAST** with four segments.

**Related reference**

[“Multisegment command input” on page 5](#)

Multisegment commands require an EOS (end-of-segment) indicator for all segments preceding the last segment, and an EOM (end-of-message) indicator for the last segment.

# Chapter 11. /CANCEL command

The **/CANCEL** command cancels all segments of a multisegment input message.

It must be entered prior to the end-of-message (EOM) indicator from the terminal that was entering the message.

Subsections:

- [“Environment” on page 127](#)
- [“Syntax” on page 127](#)
- [“Usage notes” on page 127](#)
- [“Example” on page 127](#)

## Environment

The following table lists the environments (DB/DC, DBCTL, and DCCTL) from which the command can be issued.

Table 90. Valid environments for the /CANCEL command

| Command        | DB/DC | DBCTL | DCCTL |
|----------------|-------|-------|-------|
| <b>/CANCEL</b> | X     |       | X     |

## Syntax

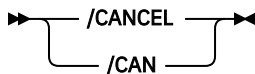

## Usage notes

Because a **/CANCEL** command must comprise a segment, it cannot be used to cancel a single-segment message.

On a non-3270 device, you can cancel a single-segment message by entering two asterisks (\*\*), followed immediately by an end-of-segment (EOS) indicator. When Message Format Service (MFS) is used, you can define delete characters other than (\*\*) to cancel other segments besides the first.

**/CANCEL** command has no meaning on display terminals where it is not possible to have some segments of a message already received by IMS while receiving subsequent segments.

## Example

Entry ET:

```
/BROADCAST TO ACTIVE (EOS)  
SYSTEM WILL BE AVAILABLE (EOS)
```

Entry ET:

```
/CANCEL
```

Response ET:

```
DFS058I  CANCEL  COMMAND  COMPLETED
```

Explanation: All previously entered segments of the current message are discarded.

---

## Chapter 12. /CHANGE commands

The **/CHANGE** commands are multisegment commands used to change or delete internal resources within IMS.

All **/CHANGE** formats require an EOM indication to denote end-of-message; an EOS indication must be included for all segments that precede the last segment.

These commands can be issued to an IMSplex using the Batch SPOC utility.

Subsections:

- [“/CHANGE APPC command” on page 129](#)
- [“/CHANGE CCTL command” on page 130](#)
- [“/CHANGE CPLOG command” on page 132](#)
- [“/CHANGE DESC command” on page 132](#)
- [“/CHANGE DIR MFS command” on page 134](#)
- [“/CHANGE FDR command” on page 135](#)
- [“/CHANGE LINK command” on page 136](#)
- [“/CHANGE NODE command” on page 140](#)
- [“/CHANGE SUBSYS command” on page 143](#)
- [“/CHANGE SURV command” on page 145](#)
- [“/CHANGE TRAN command” on page 148](#)
- [“/CHANGE UOR command” on page 149](#)
- [“/CHANGE USER command” on page 151](#)

### Related reference

[“Multisegment command input” on page 5](#)

Multisegment commands require an EOS (end-of-segment) indicator for all segments preceding the last segment, and an EOM (end-of-message) indicator for the last segment.

---

## /CHANGE APPC command

Use the **/CHANGE APPC** command to specify a change to the timeout value for APPC/MVS.

This value is set in the DFSDCxxx member of IMS.PROCLIB. IMS passes this value to APPC/z/OS for every implicit APPC/MVS conversation.

Subsections:

- [“Environment” on page 129](#)
- [“Syntax” on page 130](#)
- [“Keywords” on page 130](#)
- [“Usage notes” on page 130](#)

### Environment

The following table lists the environments (DB/DC, DBCTL, and DCCTL) in which you can use the command and keywords.

Table 91. Valid environments for the /CHANGE APPC command and keywords

| Command / Keywords | DB/DC | DBCTL | DCCTL |
|--------------------|-------|-------|-------|
| /CHANGE            | X     | X     | X     |
| APPC               | X     |       | X     |
| OUTBND             | X     | X     | X     |
| TIMEOUT            | X     | X     | X     |

## Syntax

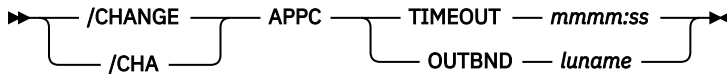

## Keywords

The following keywords are valid for the **/CHANGE APPC** command:

### OUTBND

Specifies a different outbound LU. The specified LU must be one of the APPC LUs defined in the APPCPMxx member of the SYS1.PARMLIB library. The default outbound LU is BASE LU. Message DFS182 is issued if the specified *luname* is not defined as a SCHEDULER in APPC/MVS for this IMS (in the APPCPMxx SYS1.PARMLIB member or through the **SETAPPC** command).

### TIMEOUT

Specifies the timeout value in minutes and seconds (*mmm:ss*). *mmm* can be a number between 0 and 1440. *ss* can be a number between 0 and 59. If the timeout value is 0, APPC/MVS timeout will be deactivated.

## Usage notes

A DFS34091 or DFS3491I message is issued after the **/CHANGE APPC TIMEOUT** command is issued to inform the operator of the new timeout value.

## /CHANGE CCTL command

Use the **/CHANGE CCTL** command to specify the coordinator control subsystem. The recovery elements are resolved by IMS.

Subsections:

- [“Environment” on page 130](#)
- [“Syntax” on page 131](#)
- [“Keywords” on page 131](#)
- [“Examples” on page 131](#)

## Environment

The following table lists the environments (DB/DC, DBCTL, and DCCTL) in which you can use the command and keywords.

Table 92. Valid environments for the /CHANGE CCTL command and keywords

| Command / Keywords | DB/DC | DBCTL | DCCTL |
|--------------------|-------|-------|-------|
| /CHANGE            | X     | X     | X     |
| ABORT              | X     | X     |       |
| CCTL               | X     | X     |       |
| COMMIT             | X     | X     |       |
| PRTKN              | X     | X     |       |

## Syntax

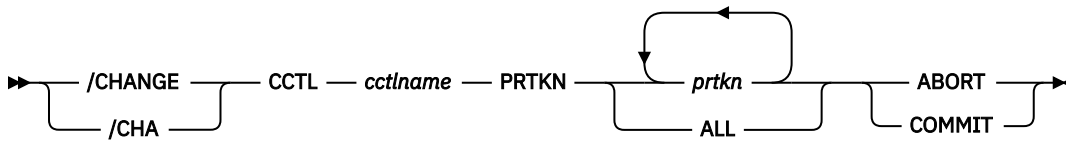

## Keywords

The following keywords are valid for the **/CHANGE CCTL** command:

### **cctlname**

Specifies CCTL subsystem ID.

### **prtkn**

Specifies the pseudorecovery token, which designates the unit of recovery to be aborted or committed. Use the **/DISPLAY CCTL** command to determine the name of the pseudorecovery token.

### **ABORT**

Backs out changes for a unit of recovery. After completion of backout, the recoverable indoubt structure (RIS) is removed.

### **COMMIT**

Commits changes for a unit of recovery. After the process is complete, the RIS is removed.

## Examples

This set of examples shows that an INDOUBT unit of recovery can be aborted if the INDOUBT status cannot be resolved. The **/CHANGE ... PRTKN** command backs out changes made to the database.

Entry ET:

```
/DISPLAY CCTL CICS1 IND
```

Response ET:

| CCTL  | PSEUDO-RTKN    | RECOVERY-TOKEN   | REGID | PSBNAME | STATUS   |
|-------|----------------|------------------|-------|---------|----------|
| CICS1 |                |                  |       |         | ATTACHED |
|       | 000100C0       | 9FFA956B7AE24E00 |       | BMP255  | INDOUBT  |
|       | 00010040       | 9FFA9568FF594301 |       | BMP255  | INDOUBT  |
|       | *90067/113446* |                  |       |         |          |

Entry ET:

```
/CHANGE CCTL CICS1 PRTKN 000100C0 ABORT (EOM)
```

Response ET:

```
DFS058I CHANGE COMMAND COMPLETED
DBS0699I REYNC ABORT COMPLETE FOR PSB BMP255...
```

Explanation: The INDOUBT unit of recovery whose pseudorecovery token (PRTKN) is 000100C0 has been aborted.

## **/CHANGE CPLOG command**

Use the **/CHANGE CPLOG** command to change the value of the IMS execution parameter, CPLOG.

The IMS CPLOG execution parameter specifies the number of system log records between system-generated checkpoints.

Subsections:

- [“Environment” on page 132](#)
- [“Syntax” on page 132](#)
- [“Keywords” on page 132](#)

### **Environment**

The following table lists the environments (DB/DC, DBCTL, and DCCTL) in which you can use the command and keywords.

*Table 93. Valid environments for the /CHANGE CPLOG command and keywords*

| <b>Command / Keywords</b> | <b>DB/DC</b> | <b>DBCTL</b> | <b>DCCTL</b> |
|---------------------------|--------------|--------------|--------------|
| <b>/CHANGE</b>            | X            | X            | X            |
| CPLOG                     | X            | X            | X            |

### **Syntax**

➤ **/CHANGE** CPLOG *cp\_log* ➤  
    **/CHA**

### **Keywords**

The following keyword is valid for the **/CHANGE CPLOG** command:

#### ***cp\_log***

This value must be specified as one or more numeric characters followed by either K or M. Values can range from 1K (1 KB) to 16M (16 MB).

## **/CHANGE DESC command**

Use the **/CHANGE DESC** command to specify the name of an LU 6.2 descriptor that will be updated with new values.

An error message is issued if the specified descriptor is not found.

Subsections:

- [“Environment” on page 133](#)
- [“Syntax” on page 133](#)



- “Keywords” on page 133
- “Usage notes” on page 134

## Environment

The following table lists the environments (DB/DC, DBCTL, and DCCTL) in which you can use the command and keywords.

*Table 94. Valid environments for the /CHANGE DESC command and keywords*

| Command / Keywords | DB/DC | DBCTL | DCCTL |
|--------------------|-------|-------|-------|
| <b>/CHANGE</b>     | X     | X     | X     |
| DESC               | X     |       | X     |
| LUNAME             | X     |       | X     |
| MODE               | X     |       | X     |
| OUTBND             | X     |       | X     |
| SIDE               | X     |       | X     |
| SYNLEVEL           | X     |       | X     |
| TPNAME             | X     |       | X     |
| TYPE               | X     |       | X     |

## Syntax

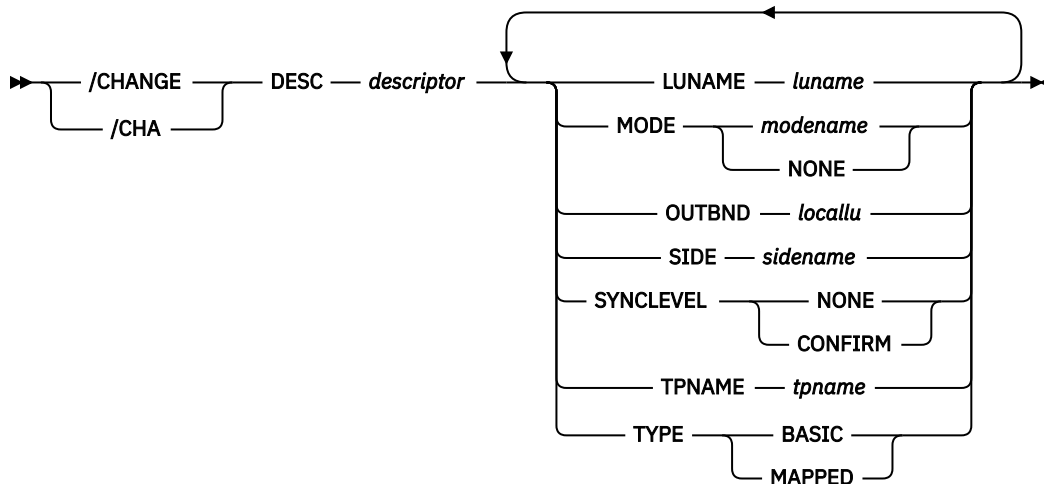

## Keywords

The following keywords are valid for the **/CHANGE DESC** command:

### LUNAME

Specifies the LU name that is updated in the LU 6.2 descriptor.

The luname value in the descriptor is set to blanks unless the LUNAME keyword is also specified. A network-qualified LU name is optional for the LUNAME keyword.

**MODE**

Specifies the VTAM mode table entry name that is updated in the LU 6.2 descriptor. The NONE parameter resets the mode field to its null state.

The MODE value in the descriptor is set to blanks unless the MODE keyword is also specified.

**OUTBND**

Identifies a local LU to be used for outbound message processing. If you do not specify a local LU, no LU name is displayed in the OUTBNDLU column of the **/DISPLAY DESC** command, and IMS uses the default LU.

**SIDE**

Specifies the APPC/z/OS side information that is set in the LU 6.2 descriptor. The side information contains default values for APPC conversation attributes such as LUNAME, TPNAME, and MODE.

**SYNCLEVEL**

Specifies the APPC sync level that is updated in the LU 6.2 descriptor. One of the following must be specified:

**CONFIRM**

IMS sync point processing continues.

**NONE**

IMS sync processing continues despite a session failure.

**TPNAME**

Specifies the tpname that is updated in the LU 6.2 descriptor. Message DFS182 is issued if the TPNAME parameter specified is DFSSIDE.

The TPNAME value in the descriptor is set to blanks unless the TPNAME keyword is also specified.

**TYPE**

Specifies the APPC conversation type that is updated in the LU 6.2 descriptor.

The conversation types are:

**BASIC**

Specifies that the data is to be formatted by the transaction programs, using the pattern "LL,data,LL,data".

**MAPPED**

Specifies that the data is to be formatted by APPC.

**Usage notes**

The **/CHANGE DESC** command changes the destination for future messages only. It does not change the destination for existing messages. The existing output messages are delivered only to the luname and tpname that had been previously specified for that message. This restriction is required by security requirements so message delivery to the intended destination only occurs at the time the messages are created.

## **/CHANGE DIR MFS command**

---

Use the **/CHANGE DIR MFS** command to specify that the entries in the MFS dynamic directory are to be deleted.

This restores the dynamic directory to the original state that it was in just after IMS was initialized.

Subsections:

- [“Environment” on page 135](#)
- [“Syntax” on page 135](#)
- [“Usage notes” on page 135](#)

## Environment

The following table lists the environments (DB/DC, DBCTL, and DCCTL) in which you can use the command and keywords.

Table 95. Valid environments for the /CHANGE DIR MFS command and keywords

| Command / Keywords | DB/DC | DBCTL | DCCTL |
|--------------------|-------|-------|-------|
| /CHANGE            | X     | X     | X     |
| DIR                | X     |       | X     |

## Syntax



## Usage notes

When IMS is initialized, IMS creates an MFS block primary directory based on the contents of all the \$\$IMSDIR members found. At the same time, IMS issues GETMAINS to acquire additional storage that is large enough to hold approximately 10% of the members in the active format library. While IMS is running, entries are only added to the dynamic directory, they are not deleted. Therefore, the dynamic directory continues to get larger until it runs out of space. When this happens, IMS can extend the amount of space in the dynamic directory to hold another 10%. IMS can extend the size of the dynamic directory a maximum of 9 times.

If you want to delete the in-storage (or index) entries from the dynamic directory without restarting IMS or performing an online change for the format library, use the **/CHANGE DIR MFS** command.

## /CHANGE FDR command

Use the **/CHANGE FDR** command to specify a change to the timeout value for IMS Fast Database Recovery surveillance.

This value is set in the DFSFDRxx member of IMS.PROCLIB. IMS uses this value to determine how long to wait before initiating a Fast Database Recovery takeover.

Subsections:

- [“Environment” on page 135](#)
- [“Syntax” on page 136](#)
- [“Usage notes” on page 136](#)

## Environment

The following table lists the environments (DB/DC, DBCTL, and DCCTL) in which you can use the command and keywords.

Table 96. Valid environments for the /CHANGE FDR command and keywords

| Command / Keywords | DB/DC | DBCTL | DCCTL |
|--------------------|-------|-------|-------|
| /CHANGE            | X     | X     | X     |

Table 96. Valid environments for the /CHANGE FDR command and keywords (continued)

| Command / Keywords | DB/DC | DBCTL | DCCTL |
|--------------------|-------|-------|-------|
| FDR                | X     | X     |       |
| TIMEOUT            | X     | X     | X     |

## Syntax

```

▶ /CHANGE — FDR — TIMEOUT — #second ▶
  |
  | /CHA
  |
  └───┘
    
```

## Usage notes

The timeout value (*#seconds*) must be at least 3 but no greater than 999.

IMS rejects this command if the active IMS subsystem is not connected to a Fast Database Recovery region.

## /CHANGE LINK command

Use the **/CHANGE LINK** command with FORCSESS, SYNCSESS, COLDSESS to override the system definition option defined for forcing resynchronization until the next **/CHANGE LINK** command or IMS cold start.

The **/CHANGE LINK** command applies only to IMS systems that are linked by Multiple Systems Coupling (MSC) when TCP/IP or VTAM is used.

Subsections:

- [“Environment” on page 136](#)
- [“Syntax” on page 137](#)
- [“Keywords” on page 137](#)
- [Examples](#)

## Environment

The following table lists the environments (DB/DC, DBCTL, and DCCTL) in which you can use the command and keywords.

Table 97. Valid environments for the /CHANGE LINK keywords

| Command / Keywords | DB/DC | DBCTL | DCCTL |
|--------------------|-------|-------|-------|
| /CHANGE LINK       | X     |       | X     |
| ASR                | X     |       | X     |
| COLDSESS           | X     |       | X     |
| FORCSESS           | X     |       | X     |
| MODE               | X     |       | X     |
| SYNCSESS           | X     |       | X     |

## Syntax

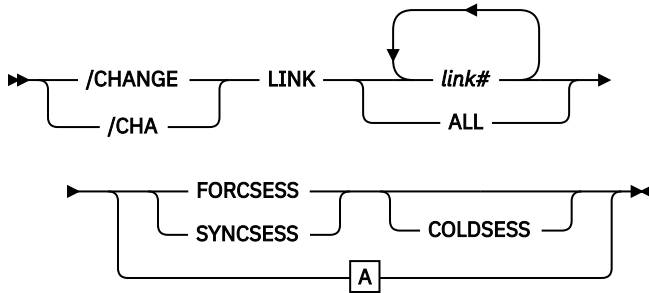

A

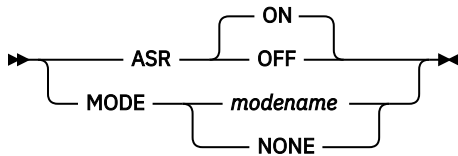

## Keywords

The following keywords are valid for the **/CHANGE LINK** command:

### FORCSESS

Defines the link as capable of being warm started from an ERE state, even if the message sequence numbers on each side of the link are not synchronized.



**Attention:** The use of FORCSESS can cause messages to be lost. Specify FORCSESS for a link only if the loss of messages during a restart can be tolerated.

### SYNCSESS

Defines the link as incapable of being warm started from an ERE state, unless the message sequence numbers on each side of the link are synchronized.

### COLDSESS

Resets a link that is in either ERE or NRE state to COLD state, the state of a link when IMS comes up with a cold start.

The FORCSESS or the SYNCSESS keyword must be specified with the COLDSESS keyword. The specification of FORCSESS or SYNCSESS keyword with COLDSESS overrides the previous specification of FORCSESS or SYNCSESS for the link.



**Attention:** Use of the COLDSESS keyword can cause messages to be lost. Use the COLDSESS keyword only if one of the systems associated with an MSC link goes down, and the only way to bring up the session is to cold start it.

The COLDSESS keyword can be specified to terminate control blocks associated with the specified link or links and reset the link to COLD. COLDSESS should be used only after the **/PSTOP** command is issued and completes against the link or links and the links appear to be hung. If COLDSESS is specified, it should be used on both sides of the link or links. Gather documentation to determine why the link or links did not come down normally.

### ASR

Changes the automatic keyword session restart designation of a VTAM link. The default parameter for ASR is ON.

Automatic session restart is not necessarily activated for a link just because a status of ASR is displayed for that link. You must also have coded SONSCIP=YES on the APPL definition statement for VTAM when defining the network for the VTAM.

ASR applies only to VTAM MSC links. Attempting to turn ASR ON for any other type of MSC link is invalid. If non-VTAM MSC links are specified on the **/CHANGE LINK ASR** command, the command response indicates that the command processing completed with exceptions.

#### MODE

Changes the default mode table name of a VTAM link. This default is usually established by system definition. Parameter NONE resets this field to its null state (as if no mode table name was specified at system definition).

MODE applies only to VTAM MSC links. Changing the mode table name for any other type of MSC link is invalid. If non-VTAM MSC links are specified on the **/CHANGE LINK MODE** command, the command response indicates that the command processing completed with exceptions.

#### Examples: FORCSESS, SYNCSESS, and COLDSESS

The following series of command examples illustrate the use the **/CHANGE LINK** command with the FORCSESS, SYNCSESS, and COLDSESS keywords. In all of the examples in this series, LINK 22 is an MSC TCP/IP link.

In the following example, LINK 22 is displayed. The link has not been used yet and is in a PSTOPPED IDLE COLD state.

```
/DISPLAY LINK 22
DFS000I LINK PARTNER RECD ENQCT DEQCT QCT SENT
DFS000I 22 TA          0    0    0    0    0 PSTOPPED IDLE COLD
```

In the following example, **/CHANGE LINK 22 FORCSESS** is issued to define the link as capable of being restarted when the message sequence numbers are not synchronized.

```
/CHANGE LINK 22 FORCSESS.
DFS058I 16:58:59 CHANGE COMMAND COMPLETED
```

In the following example, the **/DISPLAY LINK** command shows that the status of the link now includes FORCE, which indicates that the FORCSESS attribute is set on the link.

```
/DISPLAY LINK 22
DFS000I LINK PARTNER RECD ENQCT DEQCT QCT SENT
DFS000I 22 TA          0    0    0    0    0 PSTOPPED IDLE COLD FORCE
```

In the following example, the **/RSTART** command starts the link and the **/DISPLAY** command shows that the status of the link is now IDLE ACTV PRI FORCE.

```
/RSTART LINK 22
DFS058I 17:02:03 RSTART COMMAND COMPLETED
DFS2168I 17:02:05 CONNECTION ESTABLISHED ON LINK 22
/DISPLAY LINK 22
DFS000I LINK PARTNER RECD ENQCT DEQCT QCT SENT
DFS000I 22 TA          0    0    0    0    0 IDLE ACTV PRI FORCE
```

In the following example, the **/PSTOP** command is issued with the FORCE keyword, which stops the link. Because LINK 22 is a TCP/IP link, the link does not need to be shut down before issuing the **/PSTOP** command with the FORCE keyword.

After the **/PSTOP** command is processed, the reason code and LOSTSESS value in message DFS3177E indicate why the link stopped.

```
/PSTOP LINK 22 FORCE
```

```
DFS058I 17:08:01 PSTOP COMMAND COMPLETED
```

```
DFS3177E 17:08:01 MSC DETECTED AN ERROR,  
DFS000I SENDMSG , RETCODE = 00000000, RSNCODE = 00000070, LOSTSESS = FORCESTO  
DFS000I MODULE = DFSTC7C0, LINK = 022, LNK12T01
```

```
DFS2169I 17:08:01 DISCONNECTION COMPLETED ON LINK 0022
```

After the disconnection of LINK 22 is complete, a **/DISPLAY LINK** command shows the status of LINK 22 as PSTOPPED IDLE ERE FORCE IMS1. In the link status,

- ERE indicates that the link is in a warm state and that when the link is restarted, emergency restart synchronization will be performed.
- FORCE indicates that the link will start even if the message sequence numbers are not synchronized.
- IMS1 identifies the IMS system in which the link was stopped.

```
/DISPLAY LINK 22
```

```
DFS000I LINK PARTNER RECD ENQCT DEQCT QCT SENT  
DFS000I 22 TA 0 0 0 0 PSTOPPED IDLE ERE FORCE IMS1
```

In the following example, the **/CHANGE LINK** command is issued with the SYNCSESS COLDSESS keywords. The COLDSESS keyword resets the link status from ERE to COLD. The SYNCSESS keyword changes FORCESESS attribute of the link to the SYNCSESS attribute, which redefines the link as requiring the message sequence numbers on each side of the link to be synchronized before the link can start.

```
/CHANGE LINK 22 SYNCSESS COLDSESS.
```

```
DFS058I 17:08:45 CHANGE COMMAND COMPLETED
```

In the following final example of this series, the **/DISPLAY LINK** command shows that the link status no longer includes FORCE, which indicates that the FORCESESS attribute is no longer set and that the message sequence numbers must be synchronized before the link will start from a warm state.

```
/DISPLAY LINK 22
```

```
DFS000I LINK PARTNER RECD ENQCT DEQCT QCT SENT  
DFS000I 22 TA 0 0 0 0 PSTOPPED IDLE COLD
```

## Examples: ASR

This set of commands illustrates how the ASR setting of a link can be modified by the **/CHANGE** command:

Entry ET:

```
/DISPLAY LINK 6
```

Response ET:

```
LINK PARTNER RECD ENQCT DEQCT QCT SENT  
6 AL 0 0 0 0 ASR PSTOPPED IDLE COLD  
*90179/102004* IMSA
```

Explanation: Automatic Session Restart was defined for link 6 by system definition.

Entry ET:

```
/CHANGE LINK 6 ASR OFF (EOM)
```

Response ET:

```
DFS058I CHANGE COMMAND COMPLETED
```

Entry ET:

```
/DISPLAY LINK 6
```

Response ET:

```
LINK PARTNER RECD ENQCT DEQCT QCT SENT  
6 AL 0 0 0 0 0 PSTOPPED IDLE COLD  
*90179/102126*
```

Explanation: Automatic Session Restart is not available for link 6

Entry ET:

```
/CHANGE LINK 6 ASR (EOM)
```

Response ET:

```
DFS058I CHANGE COMMAND COMPLETED
```

Explanation: The ASR parameter will default to ON.

Entry ET:

```
/DISPLAY LINK 6
```

Response ET:

```
LINK PARTNER RECD ENQCT DEQCT QCT SENT  
6 AL 0 0 0 0 0 ASR PSTOPPED IDLE COLD  
*90179/102300*
```

Explanation: Automatic Session Restart is in effect again as a result of the second **/CHANGE** command.

## **/CHANGE NODE command**

Use the **/CHANGE NODE** command to specify a VTAM node to be changed. The **NODE** parameter can be generic if the **USER** keyword is not present. The generic parameter specifies nodes that already exist.

Subsections:

- [“Environment” on page 140](#)
- [“Syntax” on page 141](#)
- [“Keywords” on page 141](#)
- [“Examples” on page 142](#)

### **Environment**

The following table lists the environments (DB/DC, DBCTL, and DCCTL) in which you can use the command and keywords.

*Table 98. Valid environments for the /CHANGE NODE command and keywords*

| <b>Command / Keywords</b> | <b>DB/DC</b> | <b>DBCTL</b> | <b>DCCTL</b> |
|---------------------------|--------------|--------------|--------------|
| <b>/CHANGE</b>            | X            | X            | X            |
| ASR                       | X            |              | X            |
| COLDSESS                  | X            |              | X            |
| FORCSESS                  | X            |              | X            |
| MODE                      | X            |              | X            |



Table 98. Valid environments for the /CHANGE NODE command and keywords (continued)

| Command / Keywords | DB/DC | DBCTL | DCCTL |
|--------------------|-------|-------|-------|
| NODE               | X     |       | X     |
| SYNCSSESS          | X     |       | X     |
| USER               | X     |       | X     |

## Syntax

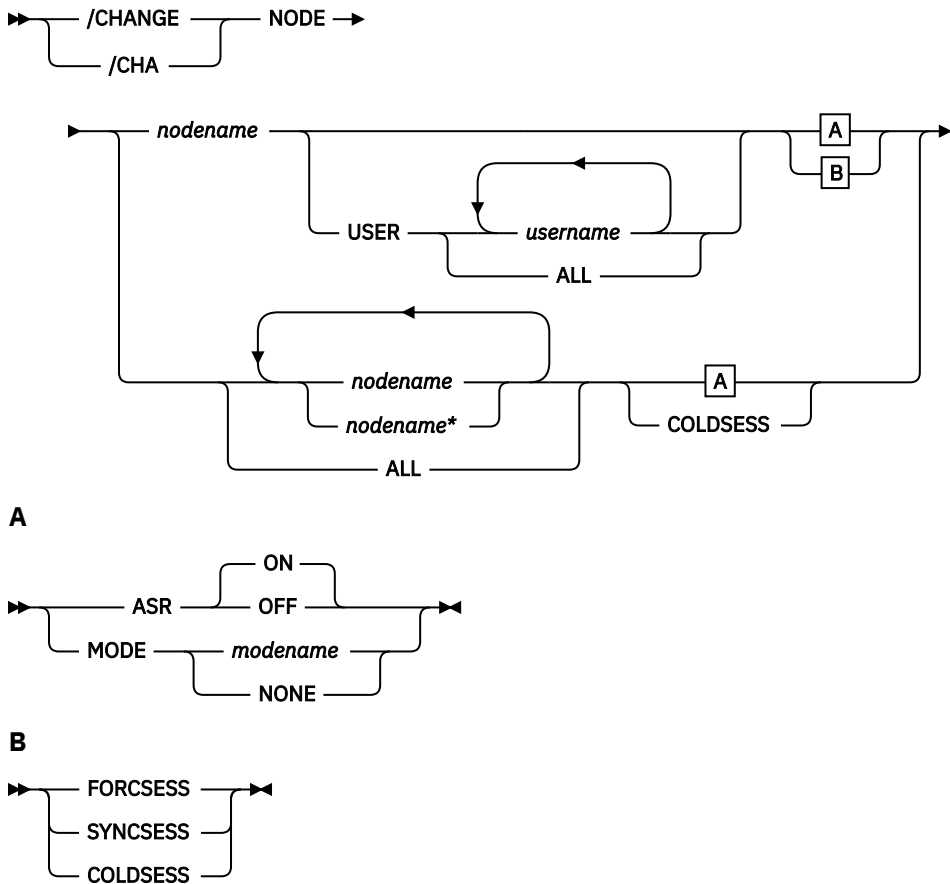

## Keywords

The following keywords are valid for the `/CHANGE NODE` command:

### ASR

The ASR keyword allows you to change the automatic session restart designation of a node. The default parameter for ASR is ON.

Automatic session restart is not necessarily activated for a node just because a status of ASR is displayed for that node. You must also have coded SONCSIP=YES on the APPL definition statement for VTAM when defining your network.

### COLDSESS

When COLDSESS is used with the NODE keyword, it sets up the SLU P or FINANCE session so that the session can be cold started. The COLDSESS keyword should be used if the SLU P or FINANCE session has experienced problems and attempts to warm start the session fail. The COLDSESS keyword

terminates terminal and user control blocks associated with the specified node or nodes, and resets the node status to COLD.

In an IMSplex, if global resource information is not kept in Resource Manager (RM), the change is applied locally. If global resource information is kept in RM, the change is applied globally.

A DFS0581 COMMAND COMPLETE EXCEPT message may be received if the node is temporarily in use by another task even if the criteria (node is terminated and idle) for successful completion of the command is met.

### **FORCSESS, SYNCSESS**

The FORCSESS and SYNCSESS keywords are valid only for ISC nodes. Specify FORCSESS and SYNCSESS to override the system definition or logon descriptor option defined to force or not force synchronization of sessions. This override is effective until the next **/CHANGE** command is issued or an IMS cold start is effected.

### **MODE**

Changes the default mode table name of a node. This default is usually established by system definition or logon descriptor. MODE resets this field to its null state (as if no mode table name had been specified at system definition).

Changing ASR or the mode table name for VTAM 3270 nodes is invalid. If nodes of this type are referred to specifically in the **/CHANGE ASR** or **/CHANGE MODE** commands, they are marked in error.

### **USER**

Indicates the ISC user that is allocated to the node or the dynamic user that is signed on to the node.

**/CHANGE USER AUTOLOGON SAVE** changes the autologon information previously specified by a user descriptor, Destination Creation exit routine (DFSINSX0), or signon exit routine (DFSSGNX0). The autologon change is saved. The autologon information includes the node name, the mode table, the logon descriptor, and the ID. If the Resource Manager is active, the user will be dynamically created if it does not already exist. The SAVE keyword must be specified. If SAVE is not specified, the command is rejected with message DFS1199.

#### **Restrictions for using NODE and USER parameters together:**

- Commands with the NODE USER keyword pair are valid only if:
  - The USER is signed on to the NODE
  - In an ISC environment, the USER is allocated to the NODE
  - The nodes and users already exist
- **/CHANGE NODE USER** commands with ASR or MODETABLE keyword are valid for ISC and non-ISC nodes and users.
- **/CHANGE NODE USER** commands with FORCSESS or SYNCSESS keyword are valid for ISC nodes only.

### **Examples**

The following are examples of the **/CHANGE NODE** command:

#### **Example 1**

Entry ET:

```
/DISPLAY NODE LUTYPEP1 MODE
```

Response ET:

```
NODE-USR  TYPE  DEF MODETBL  ACT MODETBL
LUTYPEP1  SLUP  DEFRESP
*90179/100630*
```

Explanation: DEFRESP is the mode table name defined for node LUTYPEP1 at system definition or logon descriptor or resource creation. The session is not active so the active mode table field (ACT MODETBL) is blank.

Entry ET:

```
/CHANGE NODE LUTYPEP1 MODE XXXXXXXX (EOM)
```

Response ET:

```
DFS058I CHANGE COMMAND COMPLETED
```

Entry ET:

```
/DISPLAY NODE LUTYPEP1 MODE
```

Response ET:

```
NODE-USR TYPE DEF MODETBL ACT MODETBL
LUTYPEP1 SLUP XXXXXXXX
*84179/100733*
```

Explanation: The default mode table name has been changed to XXXXXXXX by the previous **/CHANGE** command. The session is still not active so the active mode table field (ACT MODETBL) is blank.

### Example 2

Entry ET:

```
/DISPLAY NODE LUTYPEP
```

Response ET:

```
NODE-USR TYPE CID RECD ENQCT DEQCT QCT SENT
LUTYPEP SLUP 00000000 37 37 37 0 37 IDLE
*98276/153630*
```

Explanation: Node LUTYPEP is terminated warm after session received and processed 37 messages.

Entry ET:

```
/CHANGE NODE LUTYPEP COLDSESS (EOM)
```

Response ET:

```
DFS058I CHANGE COMMAND COMPLETED
```

Entry ET:

```
/DISPLAY NODE LUTYPEP
```

Response ET:

```
NODE-USR TYPE CID RECD ENQCT DEQCT QCT SENT
LUTYPEP SLUP 00000000 0 0 0 0 0 IDLE COLD
*98279/153630*
```

Explanation: Terminal and user blocks associated with node LUTYPEP have been cleared and the status has been reset to COLD.

## **/CHANGE SUBSYS** command

Use the **/CHANGE SUBSYS** command to specify the subsystem name from which IMS recovery elements are to be deleted.

Subsections:

- [“Environment” on page 144](#)
- [“Syntax” on page 144](#)
- [“Keywords” on page 144](#)
- [“Examples” on page 144](#)

## Environment

The following table lists the environments (DB/DC, DBCTL, and DCCTL) in which you can use the command and keywords.

*Table 99. Valid environments for the /CHANGE SUBSYS command and keywords*

| Command / Keywords | DB/DC | DBCTL | DCCTL |
|--------------------|-------|-------|-------|
| <b>/CHANGE</b>     | X     | X     | X     |
| OASN               | X     | X     | X     |
| RESET              | X     | X     | X     |
| SUBSYS             | X     | X     | X     |

## Syntax

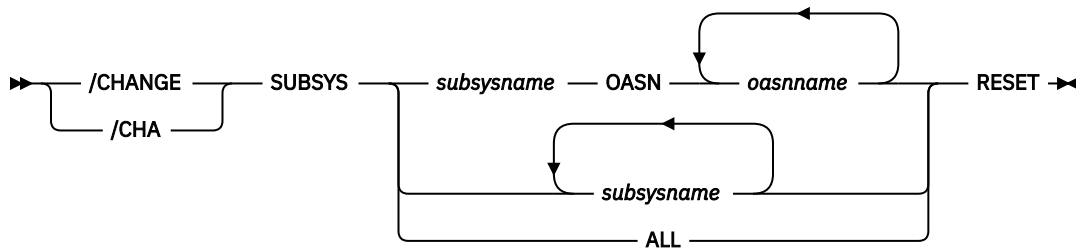

## Keywords

The following keywords are valid for the **/CHANGE SUBSYS** command:

### OASN

Specifies the outstanding recovery element to be deleted.

### RESET

Causes an incomplete unit of work assigned to an external subsystem (not a CCTL subsystem) to be deleted.

## Examples

The following are examples of the **/CHANGE SUBSYS** command:

### Example 1

Entry ET:

```
/CHANGE SUBSYS DSN RESET (EOM)
```

Response ET:

```
DFS058I  CHANGE COMMAND COMPLETED
```

Explanation: Reset all IN-DOUBT recovery units for subsystem DSN.

### Example 2

Entry ET:

```
/CHANGE SUBSYS ALL RESET (EOM)
```

Response ET:

```
DFS058I  CHANGE COMMAND COMPLETED
```

Explanation: Reset all IN-DOUBT recovery units for all subsystems.

### Example 3

Entry ET:

```
/CHANGE SUBSYS ABCD OASN 99 685 2920 RESET (EOM)
```

Response ET:

```
DFS058I  CHANGE COMMAND COMPLETED
```

Explanation: Reset IN-DOUBT recovery units identified by OASN numbers 99, 685, 2920 for subsystem ABCD.

## **/CHANGE SURV command**

Use the **/CHANGE SURV** command to specify that the interval or timeout value on the active or alternate system in an XRF environment is changed.

Subsections:

- [“Environment” on page 145](#)
- [“Syntax” on page 145](#)
- [“Keywords” on page 146](#)
- [“Usage notes” on page 146](#)
- [“Examples” on page 147](#)

### Environment

The following table lists the environments (DB/DC, DBCTL, and DCCTL) in which you can use the command and keywords.

*Table 100. Valid environments for the /CHANGE SURV command and keywords*

| Command / Keywords | DB/DC | DBCTL | DCCTL |
|--------------------|-------|-------|-------|
| <b>/CHANGE</b>     | X     | X     | X     |
| INTERVAL           | X     |       | X     |
| SURV               | X     |       | X     |
| TIMEOUT            | X     | X     | X     |

### Syntax

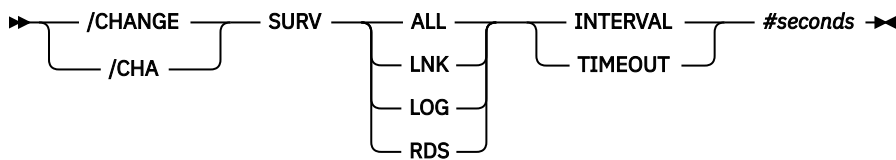

## Keywords

The following keywords are valid for the **/CHANGE SURV** command:

### ALL

Same as specifying LNK, LOG, and RDS.

### INTERVAL

Specifies the new interval on the active or alternate system in an XRF environment. The INTERVAL keyword identifies the new value in seconds and must be in the range 1 through 99.

### LNK

IMS ISC link.

### LOG

IMS system log.

### RDS

IMS restart data set.

### TIMEOUT

Specifies the new timeout value on the active or alternate system in an XRF environment. The TIMEOUT keyword identifies the new value in seconds and must be in the range 1 through 99.

## Usage notes

When **/CHANGE SURV** is entered on the active system, it becomes effective on both the active and alternate systems if the alternate system is up. If entered on the alternate system, only the alternate system is changed.

**Recommendation:** Change surveillance on the active system and allow the alternate system to take affect.

Additional considerations when changing the TIMEOUT values are shown in the following table. Listed in the table are the TIMEOUT value requirements for certain systems where the command is entered on and the action taken for exceptions.

*Table 101. Changing the TIMEOUT value*

| System the command is entered on | Requirement  | Action taken for exceptions   |
|----------------------------------|--|---|
| Active                           | New timeout value must be greater than or equal to twice the active interval value.    | DFS3832 issued. Active timeout value forced to twice the active interval value.       |
| Alternate                        | Alternate interval value must be greater than or equal to the active interval value.   | DFS3812 issued. Alternate interval value forced to active interval value.             |
| Alternate                        | New timeout value must be greater than or equal to twice the alternate interval value. | DFS3832 issued. Alternate timeout value forced to twice the alternate interval value. |

Additional considerations when changing the INTERVAL values are shown in the following table. Listed in the table are the INTERVAL value requirements for certain systems where the command is entered and the action taken for exceptions.

Table 102. Changing the INTERVAL value

| System the command is entered on | Requirement   | Action taken for exceptions   |
|----------------------------------|---|---|
| Active                           | Twice the new interval value must be less than or equal to the active timeout value.                            | DFS3832 issued. Active timeout value forced to twice the new interval value.              |
| Alternate                        | Alternate interval value must be greater than or equal to the active interval value.                            | DFS3812 issued. Alternate interval value forced to active interval value.                 |
| Alternate                        | New alternate interval value must be greater than or equal to the alternate LOG interval value (LNK and RDS).   | DFS3833 issued. Alternate interval value forced to alternate log interval value.          |
| Alternate                        | New alternate interval value must be less than or equal to the alternate RDS and LNK interval value (LOG only). | DFS3833 issued. Alternate interval value forced to alternate RDS then LNK interval value. |
| Alternate                        | Twice the new interval value must be less than or equal to the alternate timeout value.                         | DFS3832 issued. Alternate timeout value forced to twice the new interval value.           |

## Examples

This set of commands illustrates how surveillance can be modified by the **/CHANGE** command.

Entry ET (Alternate system):

```
/DISPLAY HSB
```

Response ET (Alternate system):

```

RSENAME      STATUS   PHASE   IMS-ID   VTAM UVAR  ACT-ID   LOG-TIME
DFSRSENM     BACKUP  TRK     IMSB     USERVAR  IMSA    10:35:17
              BACKUP  SYSTEM
SURVEILLANCE INTERVAL TIMEOUT STATUS  INTERVAL SYSTEM STATUS
LOG           2       99  INACTIVE      2       99  INACTIVE
LNK           4       99  INACTIVE      4       99  INACTIVE
RDS           3       99  INACTIVE      3       99  INACTIVE
TAKEOVER CONDITIONS - ALARM AUTO
RDS LINK LOG          *RDS LINK
VTAM                 *IRLM
*91226/103517*
```

Entry ET (Alternate system):

```
/CHANGE SURV LNK INTERVAL 3 (EOM)
```

Response ET (Alternate system):

```

DFS058I CHANGE COMMAND COMPLETED
DFS3812I BACKUP LNK INTERVAL VALUE OF 3 HAS BEEN FORCED TO ACTIVE VALUE OF 4
DFS3811I LNK SURVEILLANCE INACTIVE: INTERVAL VALUE CHANGED FROM 4 TO 4
```





Entry ET:

```
/DISPLAY TRAN SKS7
```

Response ET:

```
TRAN  CLS  ENQCT  QCT  LCT  PLCT  CP  NP  LP  SEGSZ  SEGNO  PARLM  RC
SKS7   7    0    0 65535 65535  8  8  8    0    0    1  0
      PSBNAME: DFSDDL7
      STATUS: BAL( 2)
      *90226/134816*
```

Explanation: The status of transaction SKS7 indicates it is eligible for load balancing (BAL) and that two regions can be simultaneously scheduled.

Entry ET:

```
/CHANGE TRANSACTION SKS7 MAXRGN 4 (EOM)
```

Response ET:

```
DFS058I CHANGE COMMAND COMPLETED
```

Entry ET:

```
/DISPLAY TRAN SKS7
```

Response ET:

```
TRAN  CLS  ENQCT  QCT  LCT  PLCT  CP  NP  LP  SEGSZ  SEGNO  PARLM  RC
SKS7   7    0    0 65535 65535  8  8  8    0    0    1  0
      PSBNAME: DFSDDL7
      STATUS: BAL( 4)
      *90226/134845*
```

Explanation: The maximum number of regions that can be simultaneously scheduled for transaction SKS7 has been changed from 2 to 4.

## **/CHANGE UOR command**

Use the **/CHANGE UOR** command to specify that IMS should resolve units of recovery (UORs) for protected resources on the z/OS Resource Recovery Services (RRS) platform.

**Recommendation:** Use the **/CHANGE UOR** command only when you are certain that no other resource managers would be adversely affected after IMS resolves the UOR.

Subsections:

- [“Environment” on page 149](#)
- [“Syntax” on page 150](#)
- [“Keywords” on page 150](#)
- [“Examples” on page 150](#)

### **Environment**

The following table lists the environments (DB/DC, DBCTL, and DCCTL) in which you can use the command and keywords.

| Command / Keywords | DB/DC | DBCTL | DCCTL |
|--------------------|-------|-------|-------|
| <b>/CHANGE</b>     | X     | X     | X     |

Table 104. Valid environments for the /CHANGE UOR command and keywords (continued)

| Command / Keywords | DB/DC | DBCTL | DCCTL |
|--------------------|-------|-------|-------|
| ABORT              | X     | X     |       |
| COMMIT             | X     | X     |       |
| UOR                | X     | X     |       |

## Syntax

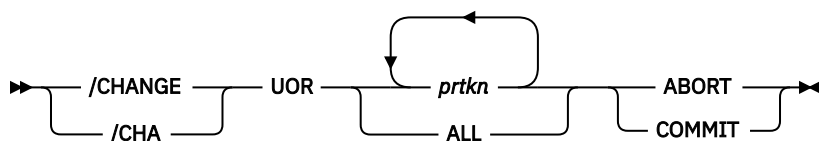

## Keywords

The following keywords are valid for the **/CHANGE UOR** command:

### *prtkn*

Specifies the pseudorecovery token that designates the UOW to be committed. Use the **/DISPLAY UOR** command to obtain the pseudorecovery token (*prtkn*).

If you specify ALL, the **/CHANGE UOR** command affects all units of recovery.

### **ABORT**

Specifies that IMS back out changes for the protected resources.

### **COMMIT**

Specifies that IMS make changes permanent for the protected resources.

## Examples

The following commands illustrate the changing of a unit of recovery.

Entry ET:

```
/CHANGE UOR 010040 ABORT
```

Response ET:

```
DFS058I CHANGE COMMAND COMPLETED
DFS0699I RESYNC ABORT COMPLETE FOR PSB STLDDTL1, PRTKN=00010040,
        TOKEN IMS2      0000000100000000 IMS2
*97226/134816*
```

Explanation: IMS backs out changes for pseudorecovery token 010040.

Entry ET:

```
/CHANGE UOR 010040 COMMIT
```

Response ET:

```
DFS058I CHANGE COMMAND COMPLETED
DFS0699I RESYNC COMMIT COMPLETE FOR PSB STLDDTL1, PRTKN=00010040,
        TOKEN IMS2      0000000100000000 IMS2
*97226/134816*
```

Explanation: IMS makes changes for pseudorecovery token 010040 permanent.

## **/CHANGE USER command**

Use the **/CHANGE USER** command to specify that an ETO user will change. The user parameter cannot be generic.

Subsections:

- [“Environment” on page 151](#)
- [“Syntax” on page 151](#)
- [“Keywords” on page 151](#)

### **Environment**

The following table lists the environments (DB/DC, DBCTL, and DCCTL) in which you can use the command and keywords.

*Table 105. Valid environments for the /CHANGE USER command and keywords*

| <b>Command / Keywords</b> | <b>DB/DC</b> | <b>DBCTL</b> | <b>DCCTL</b> |
|---------------------------|--------------|--------------|--------------|
| <b>/CHANGE</b>            | X            | X            | X            |
| AUTOLOGON                 | X            |              | X            |
| ID                        | X            |              | X            |
| LOGOND                    | X            |              | X            |
| MODE                      | X            |              | X            |
| NOSAVE                    | X            |              | X            |
| SAVE                      | X            |              | X            |
| USER                      | X            |              | X            |

### **Syntax**

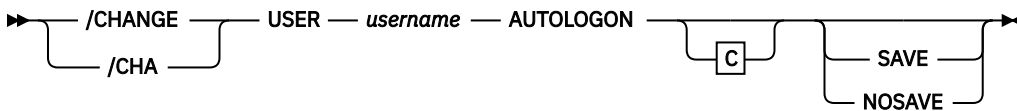

**C**

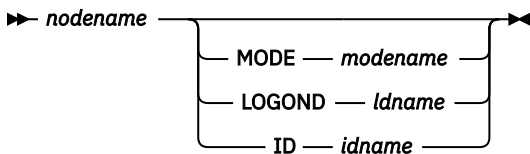

### **Keywords**

The following keywords are valid for the **/CHANGE USER** command:

**AUTOLOGON**

Specifies that the autologon information previously specified by a user descriptor, the Destination Creation exit routine (DFSINSX0), or the signon exit routine (DFSSGNX0) is being updated dynamically.

**nodename**

Specifies the autologon terminal session for the specified user. Omitting the nodename clears all autologon information.

**MODE**

Specifies the VTAM mode table entry name.

**LOGOND**

Specifies the logon descriptor used to build the terminal control blocks.

**ID**

Specifies the ISC partner's half-session qualifier (if the terminal is ISC).

**NOSAVE**

Indicates that the changed autologon information should not be retained. Deletion of the user occurs when an IMS checkpoint is taken, at session termination, IMS restart, or XRF takeover. If SAVE and NOSAVE are omitted, IMS uses the system-wide default as specified in the DFSDCxxx PROCLIB member.

**SAVE**

Indicates that the changed autologon information should be retained. This keyword prevents deletion of the user and remains in effect across a restart or XRF takeover until another **/CHANGE** command with the NOSAVE option is issued. If SAVE and NOSAVE are omitted, IMS uses the system-wide default as specified in the DFSDCxxx PROCLIB member.

If global resource information is kept in Resource Manager, the change is applied globally when the SAVE keyword is specified. If SAVE is not specified in this environment, the command is rejected.

## Chapter 13. /CHECKPOINT command

The **/CHECKPOINT** command records control and status information about the system log.

Subsections:

- “Environment” on page 153
- “Syntax” on page 153
- “Keywords” on page 154
- “Usage notes” on page 156
- “Examples” on page 157

### Environment

The following table lists the environments (DB/DC, DBCTL, and DCCTL) in which you can use the command and keywords.

Table 106. Valid environments for the /CHECKPOINT command and keywords

| Command / Keyword  | DB/DC | DBCTL | DCCTL |
|--------------------|-------|-------|-------|
| <b>/CHECKPOINT</b> | X     | X     | X     |
| ABDUMP             | X     | X     | X     |
| DUMPQ              | X     |       | X     |
| FREEZE             | X     | X     | X     |
| LEAVEGR            | X     |       | X     |
| LEAVEPLEX          | X     | X     | X     |
| NOCQSSHUT          | X     |       | X     |
| PURGE              | X     | X     | X     |
| QUIESCE            | X     |       | X     |
| SNAPQ              | X     |       | X     |
| STATISTICS         | X     | X     | X     |

### Syntax

#### Shutdown checkpoint

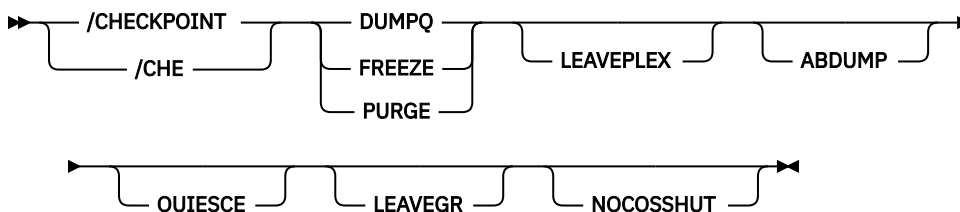

**Attention:** This command shuts down your IMS system. Be sure that you understand the consequences of shutting down the system before you issue this command.

## Simple checkpoint



## Statistics checkpoint



## Keywords

The following keywords are valid for the **/CHECKPOINT** command:

### (blank)

Requests a simple checkpoint. Simple checkpoints are also invoked by IMS based on the number of entries to the system log. The number of log entries between simple checkpoints is specified during system definition. In an ETO environment, any dynamic nodes, LTERMs or users with no messages queued or status are deleted.

### ABDUMP

Requests an abnormal termination dump of the IMS control region in addition to the shutdown option selected.

In a DBCTL environment, when **/CHECKPOINT FREEZE ABDUMP** is entered, all of the DBCTL address spaces are dumped.

### FREEZE | DUMPQ | PURGE

Requests a shutdown of IMS. These variations of shutdown are provided for control over the method of stopping programs and lines, and to control the method of disposing of queues. The effects of these variations are shown in [Table 107 on page 155](#). The request for a checkpoint shutdown might not be responded to immediately if any dependent regions are active. IMS will wait until these regions complete their current processing before continuing with the checkpoint shutdown. Message resynchronization for a specified transaction pipe does not affect IMS shutdown.

**Restriction:** A shutdown checkpoint is not allowed in a shared-queues environment if the CQS is not available.

Connections to external subsystems (not CCTL subsystems) will be quiesced. Connection attempts originating from dependent regions will be prohibited. After all dependent region connections have terminated, the control region will terminate its connection.

The FREEZE keyword shuts down IMS pending actions shown in [Table 107 on page 155](#). For DBCTL, active CCTL threads are allowed to complete before this keyword takes effect. This is also true when ABDUMP is used with this keyword. In the DBCTL environment, a **/CHECKPOINT** command with the PURGE keyword will be processed as though the FREEZE keyword was used instead of PURGE. **/CHECKPOINT FREEZE** in the DBCTL environment is correct because there are no message queues to empty.

The DUMPQ and SNAPQ keywords designate starting points from which the message queue data sets can be rebuilt. However, the SNAPQ option dumps the message queues online while IMS is running without causing a shutdown of IMS.

The PURGE keyword attempts to empty all the queues so that no outstanding work remains. For DBCTL, IMS performs FREEZE processing because there are no message queues.

In a DBCTL environment, when **/CHECKPOINT FREEZE ABDUMP** is entered, all of the DBCTL address spaces are dumped.

In a shared-queues environment, the DUMPQ and PURGE keywords cause IMS to shut down (as if you entered a **/CHECKPOINT FREEZE** command), but the message queues are not dumped or purged.

because the local IMS subsystem has no local queues. To dump the shared message queues when CQS terminates, use the **/CQSET** command before issuing the IMS shutdown checkpoint command.

The following table displays when to issue one of the three IMS shutdown options (FREEZE, DUMPQ, and PURGE) and the effect on the IMS resource.

*Table 107. IMS shutdown options and their effect on IMS resources*

| <b>Resource status</b>                   | <b>FREEZE keyword</b>  | <b>DUMPQ keyword</b>                            | <b>PURGE keyword</b>               |
|--|--|---|------------------------------------|
| Message processing regions stopped       | At program completion  | At program completion                           | When transaction queues are empty  |
| Batch message processing regions stopped | At checkpoint, SYNC call, or program completion  | At checkpoint, SYNC call, or program completion | At program completion              |
| Line input stopped                       | At message completion  | At message completion                           | At message completion              |
| Line output stopped                      | At message completion  | At message completion                           | When all messages complete         |
| Transaction and message queues           | Retained in queue data sets  | Dumped to system log                            | Emptied normally                   |
| Message-driven regions stopped           | At message completion  | At program completion                           | When transaction queues are empty  |
| Fast Path output messages queued         | Dumped to system log   | Dumped to system log                            | Emptied normally                   |
| Fast Path input messages queued          | Discarded  | Emptied normally                                | Emptied normally                   |
| Fast Path DEDB online utility region     | At program completion  | At program completion                           | At program completion              |
| Fast Path DEDBs                          | Closed   | Closed  | Closed                             |
| MSDBs                                    | Dumped to MSDB checkpoint data set   | Dumped to MSDB checkpoint data set              | Dumped to MSDB checkpoint data set |
| CCTL Regions                             | See <a href="#">DRA thread statistics (System Programming APIs)</a> for a discussion of DRA threads. |   |                                    |

### **LEAVEGR**

Deletes all affinities from the VTAM affinity table for the IMS subsystem on which this command is issued. Using this keyword removes the IMS subsystem from the generic resource group.

**Recommendation:** Cold start the DC component of an IMS subsystem that has been shut down with the LEAVEGR keyword to ensure that all affinities in IMS control blocks are also deleted. The IMS subsystem rejoins the generic resource group during startup.

If the VTAM ACB is closed (usually because of a **/STOP DC** command), a shutdown checkpoint command with the LEAVEGR keyword is rejected.

### **LEAVEPLEX**

In an IMSplex, this keyword is specified if the IMS that is being shut down is not going to rejoin the IMSplex. Specify the LEAVEPLEX keyword when you do not intend to bring the IMS back up in the IMSplex.

If LEAVEPLEX is specified, and the IMS is a member of an IMSplex with global online change enabled, an attempt is made to remove the IMS ID from the OLCSTAT data set. If there is any error in removing the IMS ID from the OLCSTAT, message, DFS3443, DFS3444, or DFS3448 is written out to the system

console and the IMS is shut down. In this case, the IMS ID might still be in the OLCSTAT data set and will have to be deleted by using the DFSUOLC utility.

When an IMS is defined to the IMSRSC repository and is leaving the IMSplex, ensure you clean up the information in the IMSRSC repository before or after the **/CHE FREEZE | DUMPQ | PURGE LEAVEPLEX** command is issued.

The **DELETE DEFN TYPE(IMSIDMBR) FOR(IMSID(imsid))** command, where IMSID is the IMS ID of the IMS leaving the IMSplex, must be issued in order to clean-up the information of the IMS from the repository. This command can be issued before the shutdown when the LEAVEPLEX keyword is issued or from another IMS after the IMS has left the IMSplex.

On a XRF system, if the active and alternate are leaving the IMSplex then the **DELETE DEFN TYPE(IMSIDMBR)** command must be issued with the IMS ID of both the active and the alternate.

**Note:**

- Turn off or disable autoexport to the IMSRSC repository using the **UPD IMS SET(AUTOEXPORT(N))** command at the active IMS before the **DELETE DEFN TYPE(IMSIDMBR)** command is issued to remove the IMS ID from the repository.
- Issue the **DELETE DEFN TYPE(IMSIDMBR)** command for an active IMS just before it is being shutdown with the LEAVEPLEX keyword.
- Do not route the **EXPORT DEFN TARGET(REPO)** command to the IMS after its IMS ID has been removed from the repository.

**NOCQSSHUT**

Is used with the **/CHE DUMPQ**, **/CHE FREEZE**, or **/CHE PURGE** commands to not shut down the CQS address space when the IMS control region terminates. The CQS address space remains active and connected to the message queue structures. NOCQSSHUT is only applicable when IMS is running in a shared-queues environment. The default is to shut down the CQS address space when the IMS control region terminates.

**QUIESCE**

Halts processing of all VTAM terminals. When QUIESCE is specified, IMS sends the VTAM shutdown indicator to all VTAM terminals and waits until these nodes have completed processing before performing the normal checkpoint shutdown. During the processing of a quiesce shutdown, the master terminal operator might want to terminate the VTAM network without waiting for the orderly termination to complete. This can be done by entering the **/CHECKPOINT** command again, either with FREEZE, DUMPQ, or PURGE but without QUIESCE.

**SNAPQ**

Requests a simple checkpoint and dumps the contents of the message queues to the system log.

In a shared-queues environment, **/CHECKPOINT SNAPQ** does not snap the queues because the local IMS subsystem has no local queues. Use the **/CQCHKPT** command to initiate a CQS structure checkpoint.

In an XRF environment, **/CHECKPOINT SNAPQ** synchronizes the active and alternate IMS subsystems.

**STATISTICS**

Requests that IMS performance records be created and written to the system log. No other checkpoint processing occurs.

The **/CHECKPOINT STATISTICS** command does not create a system checkpoint on the log.

**Usage notes**

The **/CHECKPOINT** command can be used to take a simple checkpoint of IMS, with the option of also dumping the contents of the message queue data sets to the system log or to shut down IMS normally. When IMS is shut down by the **/CHECKPOINT** command, it can be restarted with the **/NRESTART** command.



This command can be issued to an IMSplex using the Batch SPOC utility.

There are two conditions under which IMS cannot complete a shutdown normally. The most frequent is when there are multiple-page messages on a master terminal non-VTAM line, paging is not complete, and the master terminal is sharing a communication line with other physical terminals. It might be necessary to use the **/ASSIGN** command to reassign the master terminal to a line by itself so that the **/IDLE** command can be issued to terminate the multiple page output. If the master terminal cannot be reassigned to another line, assign it to the system console line.

The second condition occurs when a number of system messages generated by IMS are awaiting delivery to the master terminal. All system messages destined for the master terminal will be delivered, because they can affect the way the system is restarted. The master terminal operator should acknowledge delivery of a message by causing an I/O interrupt; that is, pressing PA2, which in turn causes another message to be sent, if one exists. Another option is to assign the master terminal to the system console.

When the **/CHECKPOINT** command is used to shut down IMS, the **/BROADCAST** command can be helpful in notifying the remote terminal operators that IMS is shutting down.

If OTMA is active and a tpipe is idle for three consecutive system checkpoints, depending on certain eligibility requirements, the tpipe is removed.

### Examples

The following are examples of the **/CHECKPOINT** command:

#### **Example 1 for /CHECKPOINT command**

Entry ET:

```
/CHECKPOINT
```

Response ET:

```
DFS058I (time stamp) CHECKPOINT COMMAND IN PROGRESS  
DFS994I *CHKPT 82102/110247**SIMPLE*
```

Explanation: A simple checkpoint of IMS is written to the system log at 110247 (time) on 82102 (Julian date). The checkpoint number is 82102/110247.

#### **Example 2 for /CHECKPOINT command**

Entry ET:

```
/CHECKPOINT FREEZE
```

Response ET:

```
DFS058I (time stamp) CHECKPOINT COMMAND IN PROGRESS  
DFS994I *CHKPT 82206/120118**FREEZE*
```

Explanation: IMS is terminated after all checkpoint freeze functions are completed. The checkpoint is written to the system log at 120118 (time) on 82206 (Julian date). The checkpoint number is 82206/120118.

#### **Example 3 for /CHECKPOINT command**

Entry ET:

```
/CHECKPOINT FREEZE QUIESCE
```

Response ET:

```
DFS058I (time stamp) CHECKPOINT COMMAND IN PROGRESS  
DFS994I *CHKPT 82102/110247**FREEZE*
```

Explanation: IMS is terminated after all VTAM nodes have returned a shutdown-complete indicator to IMS and IMS has completed all checkpoint freeze functions. The checkpoint is written to the system log at 110247 (time) on 82102 (Julian date). The checkpoint number is 82102/110247.

**Example 4 for /CHECKPOINT command**

Entry ET:

```
/CHECKPOINT PURGE ABDUMP
```

Response ET:

```
DFS058I (time stamp) CHECKPOINT COMMAND IN PROGRESS  
DFS994I *CHKPT 82128/101112**PURGE*
```

Explanation: IMS is terminated after all checkpoint purge functions are completed. The checkpoint is written to the system log at 101112 (time) on 82128 (Julian date). The checkpoint number is 82128/101112.

A z/OS ABEND message is issued when the dump of the IMS control region is completed.

**Example 5 for /CHECKPOINT command**

Entry ET:

```
/CHECKPOINT PURGE
```

Response ET:

```
DFS058I (time stamp) CHECKPOINT COMMAND IN PROGRESS  
DFS994I *CHKPT 82103/131415**PURGE*
```

Explanation: IMS is terminated after all checkpoint purge functions are completed. The checkpoint is written to the system log at 131415 (time) on 82103 (Julian date). The checkpoint number is 82103/131415.

**Example 6 for /CHECKPOINT command**

Entry ET:

```
/CHECKPOINT STATISTICS
```

Response ET:

```
/DFS058I (timestamp) CHECKPOINT COMMAND IN PROGRESS  
/DFS994I STATISTICS CHECKPOINT COMMAND COMPLETED
```

Explanation: IMS performance statistics records are written to the system log. No other information is saved. This checkpoint cannot be used for a system restart.

# Chapter 14. /CLSDST command

The **/CLSDST** command causes IMS to disconnect an ISC TCP/IP or a VTAM terminal.

Subsections:

- [“Environment” on page 159](#)
- [“Syntax” on page 159](#)
- [“Keywords” on page 159](#)
- [“Usage notes” on page 160](#)
- [“Example” on page 161](#)

## Environment

The following table lists the environments (DB/DC, DBCTL, and DCCTL) in which you can use the command and keywords.

Table 108. Valid environments for the /CLSDST command and keywords

| Command / Keywords | DB/DC | DBCTL | DCCTL |
|--------------------|-------|-------|-------|
| <b>/CLSDST</b>     | X     |       | X     |
| FORCE              | X     |       | X     |
| NODE               | X     |       | X     |
| USER               | X     |       | X     |

## Syntax

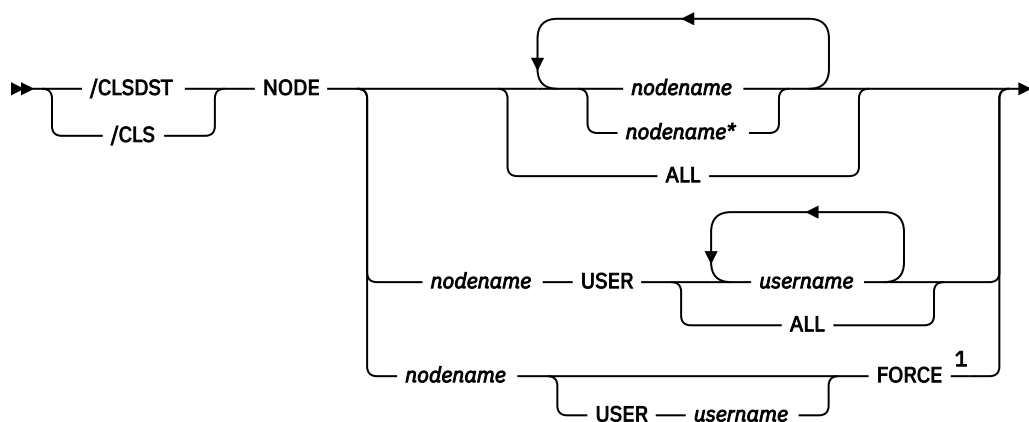

Notes:

<sup>1</sup> ISC TCP/IP nodes do not support the FORCE keyword.

## Keywords

The following keywords are valid for the **/CLSDST** command:

## FORCE

Allows IMS to reinitialize a hung node with I/O in progress. FORCE reinitializes one session and is valid only on an active IMS system. To activate FORCE on VTAM nodes, use the command **/CLSDST NODE P1 FORCE**.

For ISC VTAM nodes with parallel sessions, the USER keyword must be specified and only one USER parameter is allowed.

ISC TCP/IP nodes do not support the FORCE keyword.

FORCE operates under the following conditions:

- A display from VTAM indicates that no session exists. If a session does exist, or is in process, you must issue the VTAM command **VARY NET, INACT, FORCE** to terminate the session, and the command must successfully complete. This command terminates all parallel sessions.



**Attention:** If **VARY NET, INACT, FORCE** is not issued or does not successfully complete before you issue the **FORCE** command, and the terminal is in the process of creation or termination, the results might be unpredictable.

- The session is connected to IMS and output is in progress. A **/DISPLAY** on the node indicates that a CID exists, that the node is connected (a status of CON is displayed), and that the node is not idle (a status of IDLE is not displayed).

## NODE

Specifies the node to be disconnected by IMS. The specified node must be connected before a command is issued to disconnect it, as indicated by CON on the **/DISPLAY NODE** command referring to that terminal.

If the USER keyword is omitted for ISC nodes, all half-sessions of a session type 6 node are terminated. If the USER keyword is omitted, generic parameters are allowed for the NODE keyword.

The timing of the disconnection depends on the type of terminal:

- For keyboards or printers, console components and interactive terminals, the disconnection occurs at the next message boundary.
- For component types that group messages (such as a SLU 1 statement reader, printer, or disk), the disconnection occurs at the end of any group where processing is in progress.
- For 3270 displays, the disconnection occurs at the completion of the current (if any) I/O operation.

## USER

Must be specified with the NODE keyword. NODE USER specifies the ISC user allocated to the ISC node or the dynamic user signed on to the dynamic node. When a **/CLSDST NODE nodename USER username** command is issued, it only affects the NODE if the USER is still associated with the node.

For non-ISC dynamic nodes, this command is valid only if the user is still signed on to the node. For ISC nodes, the half-sessions of the ISC node allocated to the specific users are terminated and the users are not deallocated from the session. On restart, the **/OPNDST** command must specify the same users and ID pairs.

### Restrictions for using NODE and USER parameters together:

- Commands with the NODE USER keyword pair are valid only if:
  - The USER is signed on to the NODE
  - In an ISC environment, the USER is allocated to the NODE
  - The nodes and users already exist
- **/CLSDST NODE USER** commands are valid for ISC and non-ISC nodes and users.

## Usage notes

**/CLSDST** resets preset mode, test mode, lock node, lock LTERM, pstop LTERM, and purge LTERM, because these statuses are not significant and therefore are not kept after a logon or restart.

This command can be issued to an IMSplex using the Batch SPOC utility.

The **/CLSDST** command will also do some other cleanup depending on the recovery settings for the node. Below are the actions taken:

**RCVYSTSN=NO**

**/CLSDST** acts like a **/CHANGE NODE COLDESS** command for FINANCE and SLUP nodes by setting the session status to "cold". **/CLSDST** will act like a **/QUIESCE NODE** command for ISC (LU6.1) nodes by initiating the shutdown and deallocating the user for the specified node. This action changes the session status to cold. With these actions taken by the **/CLSDST** command, the next session initiation request for this node will be allowed to again attempt a session cold start. For ETO nodes, the control block structure could be deleted, if no significant status exists.

**RCVYCONV=NO**

**/CLSDST** causes any IMS conversations (active and held) to be terminated. Any conversational message that is queued or being processed will have its output response message delivered asynchronously.

**RCVYFP=NO**

**/CLSDST** causes Fast Path status and messages to be discarded.

**RCVYRESP=NO**

**/CLSDST** resets full-function response mode.

If global resource information is not kept in Resource Manager (RM), **/CLSDST** logs a node off and resets status locally. If global resource information is kept in RM, **/CLSDST** resets status globally. If the node has no significant status, **/CLSDST** deletes the node in RM.

If ROUTE is specified, it should be specified with ROUTE(\*). The command fails if not routed to the IMS where the node is active.

**Example**

Entry ET:

```
/CLSDST NODE WEST
```

Response ET:

```
DFS058I CLSDST COMMAND COMPLETED
```

Explanation: The node, WEST, is disconnected from IMS.



## Chapter 15. /COMPT command

The **/COMPT** command sets a particular terminal component to a ready or not-ready state.

Output messages queued for a particular component will not be sent unless the component is ready. Depending on terminal type and the availability of messages queued for other components, output operations for other components can continue.

Subsections:

- [“Environment” on page 163](#)
- [“Syntax” on page 163](#)
- [“Keywords” on page 164](#)
- [“Usage notes” on page 165](#)
- [“Examples” on page 165](#)

### Environment

The following table lists the environments (DB/DC, DBCTL, and DCCTL) in which you can use the command and keywords.

*Table 109. Valid environments for the /COMPT command and keywords*

| Command / Keywords | DB/DC | DBCTL | DCCTL |
|--------------------|-------|-------|-------|
| <b>/COMPT</b>      | X     |       | X     |
| CNS                | X     |       | X     |
| CRD                | X     |       | X     |
| NODE               | X     |       | X     |
| NOTRDY             | X     |       | X     |
| PCH                | X     |       | X     |
| PDS                | X     |       | X     |
| PRT                | X     |       | X     |
| RDR                | X     |       | X     |
| READY              | X     |       | X     |
| TDS                | X     |       | X     |
| UDS                | X     |       | X     |
| USER               | X     |       | X     |
| VID                | X     |       | X     |
| WPM1               | X     |       | X     |
| WPM2               | X     |       | X     |
| WPM3               | X     |       | X     |

### Syntax

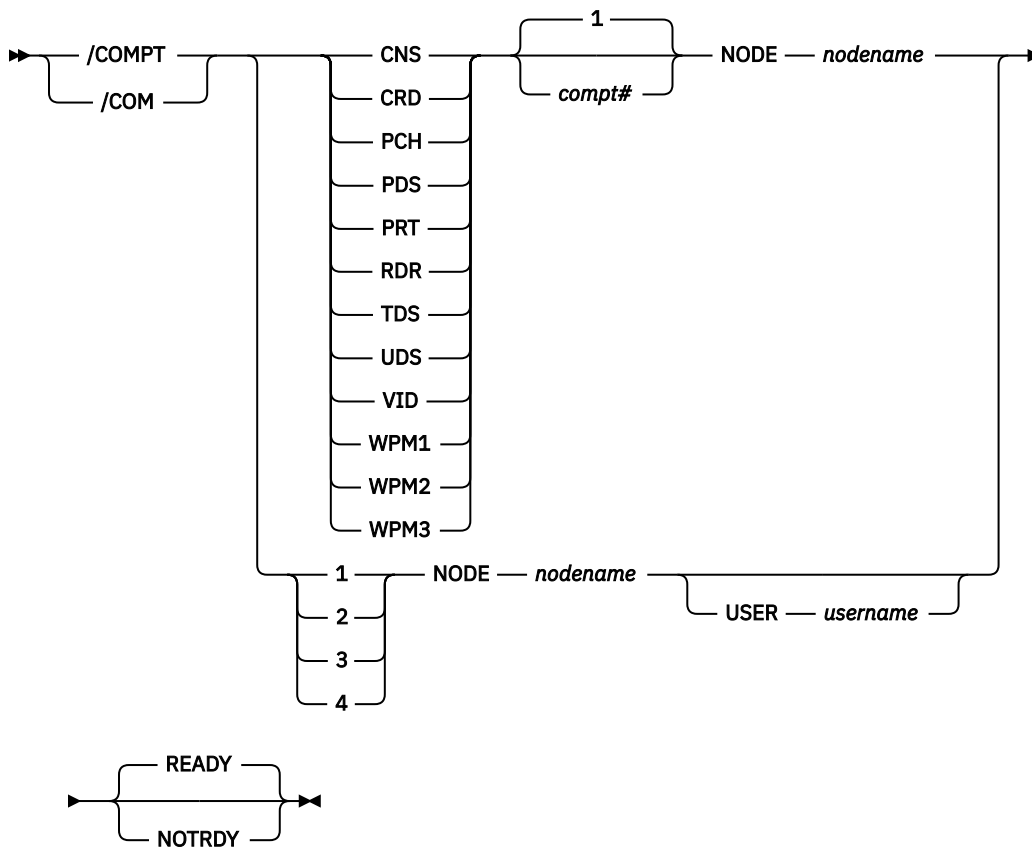

## Keywords

The following keywords are valid for the **/COMPT** command:

**CNS | CRD | PCH | PDS | PRT | RDR | TDS | UDS | VID | WPM1 | WPM2 | WPM3 | 1 | 2 | 3 | 4**

Specifies the component that you want to set to a ready or not-ready state.

The command format can take two forms. That is, a component can be referenced by using a keyword, such as VID, or by using a number, such as 2.

When a keyword is used, a search is made of the components (as defined in the **TERMINAL** macro during IMS system definition) for the component type defined that corresponds to the specified keyword.

When a match is found, that component is made ready/not ready as specified by the command. If a number other than 1 follows the keyword, the corresponding occurrence of that component type is made ready/not ready.

**/COMPT** supports up to four components. When a number from 1 through 4 is used instead of a keyword, the component affected is the one defined in that position during system definition, independent of component type.

**Restriction:** When the **/COMPT** command contains the keyword CRD, it cannot also contain any of the following keywords: WPM1, WPM2, or WPM3.

### READY

Sets the specified terminal component to a ready state.

### NOTRDY

Sets the specified terminal component to a not-ready state.



## NODE

Specifies the node name (as specified by the `TERMINAL` macro) of the terminal component that is to be set in ready or not-ready state.

## USER

Specifies the ISC subpool name of the *nodename*. The `USER` keyword is required if the node specified on the command is an ISC node.

## Usage notes

The ready or not-ready state set by the `/COMPT` command can be altered by the following:

- Another `/COMPT` command
- A `/START`, `/RSTART`, or `/RCOMPT` command
- An I/O error on the terminal component

The `/COMPT` command can only refer to a VTAM-attached terminal component.

### Restrictions for using `NODE` and `USER` parameters together:

- Commands with the `NODE USER` keyword pair are valid only if:
  - The `USER` is signed on to the `NODE`
  - In an ISC environment, the `USER` is allocated to the `NODE`
  - The nodes and users already exist
- `/COMPT (1|2|3|4) NODE USER (READY/NOTRDY)` commands are valid for ISC and non-ISC nodes and users.

## Examples

The following are examples of the `/COMPT` command:

### Example 1 for `/COMPT` command

Entry ET:

```
/COMPT 4 NODE ABC READY
```

Response ET:

```
DFS058I  COMPT COMMAND COMPLETED
```

Explanation: The fourth component defined in the `TERMINAL` macro on node `ABC` is made ready to IMS.

### Example 2 for `/COMPT` command

Entry ET:

```
/COMPT VID 2 NODE ABC READY
```

Response ET:

```
DFS058I  COMPT COMMAND COMPLETED
```

Explanation: The second display component on node `ABC` is declared operable to IMS.

## Related reference

[“/ASSIGN command” on page 103](#)

The `/ASSIGN` command alters the relationships between various IMS resources and resets certain values specified during IMS system definition.



# Chapter 16. /CQCHKPT command

The **/CQCHKPT** command initiates a CQS checkpoint for a specific coupling facility list structure or all the coupling facility list structures to which the IMS subsystem is connected.

Subsections:

- “Environment” on page 167
- “Syntax” on page 167
- “Keywords” on page 167
- “Usage notes” on page 168
- “Examples” on page 168

## Environment

The following table lists the environments (DB/DC, DBCTL, and DCCTL) in which you can use the command and keywords.

Table 110. Valid environments for the /CQCHKPT command and keywords

| Command / Keywords | DB/DC | DBCTL | DCCTL |
|--------------------|-------|-------|-------|
| <b>/CQCHKPT</b>    | X     |       | X     |
| SHAREDQ            | X     |       | X     |
| STRUCTURE          | X     |       | X     |
| SYSTEM             | X     |       | X     |

## Syntax

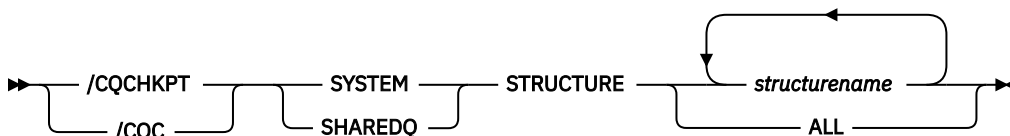

## Keywords

The following keywords are valid for the **/CQCHKPT** command:

### SHAREDQ

Specifies that the entire queue structure is to be checkpointed to the structure recovery data set. While the checkpoint is in progress for the structure, no CQS can access the structure.

During a structure checkpoint, every CQS connected to that structure also takes a system checkpoint.

**Recommendation:** When possible, issue this command when it will have the least performance impact to your online IMS subsystems.

### STRUCTURE

Specifies a specific structure name (or all) for which a CQS checkpoint is to be taken. If an overflow structure exists for a structure, a checkpoint is taken for both the primary and overflow structure.

### SYSTEM

Specifies that a system checkpoint is to be taken; the CQS internal tables are checkpointed and written to the CQS log. Only the CQS for which you enter the command takes a system checkpoint.

## Usage notes

This command sends the DFS058 CQCHKPT COMMAND IN PROGRESS message to the inputting terminal, and sends an asynchronous response to the system console and master terminal when the CQS checkpoint is complete.

This command is valid only in a shared-queues environment.

This command can be issued to an IMSplex using the Batch SPOC utility.

## Examples

The following are examples of the **/CQCHKPT** command:

### **Example 1 for /CQCHKPT command**

Entry ET:

```
/CQCHKPT SYSTEM STRUCTURE IMSMSGQ01
```

Response ET:

```
DFS058I CQCHKPT COMMAND IN PROGRESS
CQS0030I SYSTEM CHECKPOINT COMPLETE, STRUCTURE IMSMSGQ01      ,
LOGTOKEN 0000000001687D3F CQS1CQS
DFS1972I CQCHKPT SYSTEM COMMAND COMPLETE FOR STRUCTURE=IMSMSGQ01
```

Explanation: A CQS system checkpoint completes successfully.

**Recommendation:** Record the log token displayed in the CQS0030I message because you might need it for a CQS restart.

### **Example 2 for /CQCHKPT command**

Entry ET:

```
/CQCHKPT SHAREDQ STRUCTURE IMSMSGQ01
```

Response ET:

```
DFS058I CQCHKPT COMMAND IN PROGRESS
CQS0220I CQS CQS1CQS STARTED STRUCTURE CHECKPOINT FOR
STRUCTURE IMSMSGQ01      CQS1CQS
CQS0200I STRUCTURE IMSMSGQ01 QUIESCED FOR
STRUCTURE CHECKPOINT CQS1CQS
CQS0201I STRUCTURE IMSMSGQ01 RESUMED AFTER
STRUCTURE CHECKPOINT CQS1CQS
CQS0030I SYSTEM CHECKPOINT COMPLETE, STRUCTURE IMSMSGQ01      ,
LOGTOKEN 0000000001688652 CQS1CQS
CQS0221I CQS CQS1CQS COMPLETED STRUCTURE CHECKPOINT
FOR STRUCTURE IMSMSGQ01      CQS1CQS
DFS1972I CQCHKPT SHAREDQ COMMAND COMPLETE FOR STRUCTURE=IMSMSGQ01
```

Explanation: A CQS structure checkpoint for a specific structure completes successfully.

# Chapter 17. /CQQUERY command

The **/CQQUERY** command displays information regarding a specific coupling facility list structure or all the coupling facility list structures holding IMS messages.

The **/CQQUERY STATISTICS** command displays the statistics and status information for the coupling facility list structures specified by the **STRUCTURE** keyword.

Subsections:

- [“Environment” on page 169](#)
- [“Syntax” on page 169](#)
- [“Keywords” on page 169](#)
- [“Usage notes” on page 169](#)
- [“Examples” on page 170](#)

## Environment

The following table lists the environments (DB/DC, DBCTL, and DCCTL) in which you can use the command and keywords.

*Table 111. Valid environments for the /CQQUERY command and keywords*

| Command / Keywords | DB/DC | DBCTL | DCCTL |
|--------------------|-------|-------|-------|
| <b>/CQQUERY</b>    | X     |       | X     |
| STATISTICS         | X     |       | X     |
| STRUCTURE          | X     |       | X     |

## Syntax

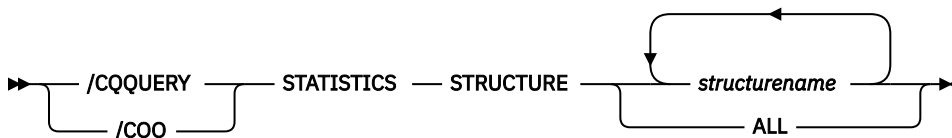

## Keywords

The following keywords are valid for the **/CQQUERY** command:

### STATISTICS

Specifies that statistics should be gathered and displayed.

### STRUCTURE

Specifies that one or more structure names follow.

Only primary, coupling facility list-structure names used by IMS for shared queues are valid.

## Usage notes

This command is valid only in a shared-queues environment.

The following statistics information is displayed:

- Number of data elements that can be allocated in the structure
- Number of list entries that can be allocated in the structure
- Number of data elements in use in the structure
- Number of list entries in use in the structure
- Entry-to-element ratio

The entry-to-element ratio is the ratio of list entries to list elements in the structure when the structure was first allocated, or last altered (for structures defined with ALLOWAUTOALT(YES)). The ratio value is initially derived by CQS from the OBJAVGSZ parameter in the CQSSGxxx PROCLIB member. The ratio can be changed by z/OS dynamically as needed for ALLOWAUTOALT(YES) structures. The ratio might also change slightly when a structure is rebuilt, because CQS uses the saved values of the actual number of allocated entries and elements to derive the entry-to-element ratio for the connection to a rebuild structure.

In an IMSplex, **/CQQUERY** displays information regarding a specific shared queue coupling facility list structure or all the shared queue coupling facility list structures holding IMS messages. **/CQQUERY** does not display any information about resource structures.

When the **/CQQ** command is issued through OM, command processing is not serialized through the IMS CTL TCB.

This command can be issued to an IMSplex by using the Batch SPOC utility.

## Examples

The following are examples of the **/CQQUERY** command:

### **Example 1 for /CQQUERY command**

Entry ET:

```
/CQQUERY STATISTICS STRUCTURE ALL
```

Response ET:

| STRUCTURE NAME | LEALLOC | LEINUSE | ELMALLOC | ELMINUSE | LE/EL       |
|----------------|---------|---------|----------|----------|-------------|
| IMSMMSGQ01     | 1789    | 11      | 1787     | 19       | 00001/00001 |
| IMSMMSGQ01OFLW | N/A     | N/A     | N/A      | N/A      | N/A         |
| IMSEMHQ01      | 377     | 3       | 375      | 3        | 00001/00001 |
| IMSEMHQ01OFLW  | N/A     | N/A     | N/A      | N/A      | N/A         |
| *08282/211714* |         |         |          |          |             |

Explanation: This command displays the structure statistics of the message queue and Fast Path EMH queue structures used by IMS. The list entries allocated (LEALLOC), the list entries in use (LEINUSE), the elements allocated (ELMALLOC) and the elements in use (ELMINUSE) show the usage of the structures. When CQS allocates a structure, it allocates a certain number of list entries and elements to manage data on the structure. A structure is full if all list entries are in use or if all elements are in use.

### **Example 2 for /CQQUERY command**

Entry ET:

```
/CQQ STATISTICS STRUCTURE IMSMSGQ01
```

Response ET:

| STRUCTURE NAME | LEALLOC | LEINUSE | ELMALLOC | ELMINUSE | LE/EL       |
|----------------|---------|---------|----------|----------|-------------|
| IMSMMSG101     | 9132    | 9027    | 9130     | 9071     | 00001/00001 |
| IMSMMSGQ01OFLW | 1915    | 1866    | 1912     | 1866     | 00001/00001 |
| *08282/211714* |         |         |          |          |             |

Explanation: This command displays the structure statistics of the message queue structure used by IMS and its associated overflow queue.

**Related concepts**

[Using structure alter for CQS \(System Administration\)](#)

**Related reference**

[CQSSGxxx member of the IMS PROCLIB data set \(System Definition\)](#)





## Chapter 18. /CQSET command

Use a **/CQSET SHUTDOWN SHAREDQ ON|OFF** command to tell CQS whether to take a structure checkpoint during normal shutdown.

You can specify a structure checkpoint for a specific coupling facility or for all coupling facility list structures used by IMS.

Subsections:

- [“Environment” on page 173](#)
- [“Syntax” on page 173](#)
- [“Keywords” on page 173](#)
- [“Usage notes” on page 174](#)
- [“Example” on page 174](#)

### Environment

The following table lists the environments (DB/DC, DBCTL, and DCCTL) in which you can use the command and keywords.

Table 112. Valid environments for the /CQSET command and keywords

| Command / Keyword | DB/DC | DBCTL | DCCTL |
|-------------------|-------|-------|-------|
| <b>/CQSET</b>     | X     |       | X     |
| SHAREDQ           | X     |       | X     |
| SHUTDOWN          | X     |       | X     |
| STRUCTURE         | X     |       | X     |

### Syntax

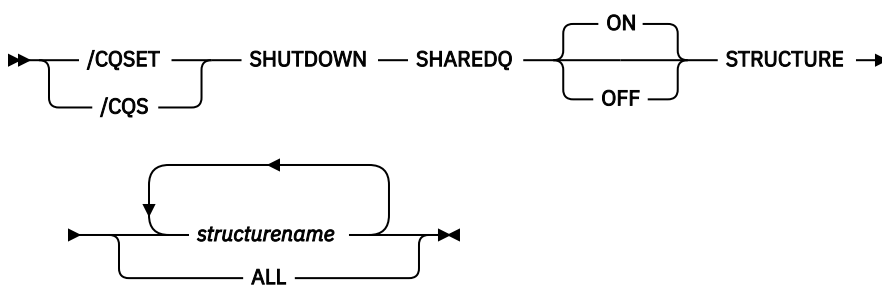

### Keywords

The following keywords are valid for the **/CQSET** command:

#### SHAREDQ

Specifies that the entire queue structure is to be checkpointed to the structure recovery data set. While the checkpoint is in progress for the structure, no CQS can access the structure.

During a structure checkpoint, every CQS connected to that structure also takes a system checkpoint.

#### SHUTDOWN

Specifies that CQS should take a structure checkpoint during normal CQS shutdown.

## STRUCTURE

Specifies a specific structure name (or all) for which a CQS checkpoint is to be taken. If an overflow structure exists for a structure, a checkpoint is taken for both the primary and overflow structure.

## Usage notes

IMS initiates a normal CQS shutdown during a normal IMS shutdown.

This command is valid only in a shared-queues environment.

In an IMSplex, when the **/CQS** command is issued through OM command processing, it is not serialized through the IMS CTL TCB.

This command can be issued to an IMSplex using the Batch SPOC utility.

## Example

Entry ET:

```
/CQSET SHUTDOWN SHAREDQ ON STRUCTURE ALL
```

Response ET:

```
DFS058I  CQSET COMMAND COMPLETE
```

Explanation: CQS will take a structure checkpoint when it shuts down.

---

## Chapter 19. CREATE commands

Use the IMS **CREATE** commands to create resources and resource descriptors.

These commands can be issued through TSO SPOC, IBM Management Console for IMS and DB2® for z/OS, the Manage Resources options in the IMS Applications menu, or other user-written programs that issue commands through OM API. These commands can also be issued to an IMSplex by using the Batch SPOC utility.

Subsections:

- [“CREATE DB command” on page 175](#)
- [“CREATE DBDESC command” on page 182](#)
- [“CREATE IMSCON commands” on page 188](#)
- [“CREATE OTMADESC command” on page 244](#)
- [“CREATE PGM command” on page 254](#)
- [“CREATE PGMDESC command” on page 265](#)
- [“CREATE RTC command” on page 274](#)
- [“CREATE RTCDESC command” on page 280](#)
- [“CREATE TRAN command” on page 285](#)
- [“CREATE TRANDESC command” on page 307](#)

---

### CREATE DB command

Use the **CREATE DB** command to create the database resource requirements for one or more physical databases managed by IMS.

Subsections:

- [“Environment” on page 175](#)
- [“Syntax” on page 176](#)
- [“Keywords” on page 176](#)
- [“Usage notes” on page 178](#)
- [“Output fields” on page 178](#)
- [“Return, reason, and completion codes” on page 179](#)
- [“Examples” on page 181](#)

#### Environment

The following table lists the environments (DB/DC, DBCTL, and DCCTL) in which you can use the command and keywords.

*Table 113. Valid environments for the CREATE DB command and keywords*

| Command / Keywords | DB/DC | DBCTL | DCCTL |
|--------------------|-------|-------|-------|
| <b>CREATE DB</b>   | X     | X     |       |
| LIKE               | X     | X     |       |
| NAME               | X     | X     |       |
| SET                | X     | X     |       |

## Syntax

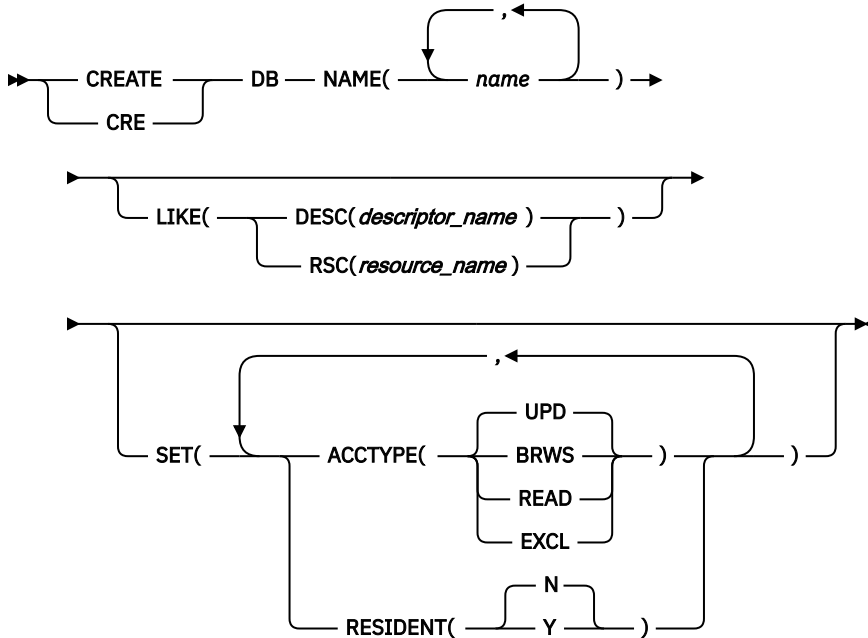

Default values shown in this syntax diagram reflect the default values that are defined in the IMS database descriptor, DFSDSDB1. If you define another descriptor as the default with a **CREATE** or **UPDATE DBDESC** command, the default values shown in this syntax diagram might not match the value defined in the current default descriptor.

## Keywords

The following keywords are valid for the **CREATE DB** command:

### LIKE

Specifies that the resource is created using an existing resource or descriptor as a model, instead of the default descriptor. The default descriptor is either the IMS descriptor DFSDSDB1, or the one that you define. The model type can either be a descriptor (DESC), or a resource (RSC). The new resource is created with all the same attributes as the model, except for the DEFAULT(Y) value. Attributes set explicitly by the **CREATE** command override the model attributes. Later changes to the model are not propagated to resources or descriptors that were created from it.

You can use **QUERY** commands to display the model name and model type used to create the resource. The model name and type returned from the **QUERY** command are provided for informational purposes only. The **EXPORT** command exports a resource definition, including the model name and model type, to the definition member. The **IMPORT** command imports a resource definition, including the model name and model type, from the definition member. An **IMPORT** command that creates a resource saves the model name and model type, but does not use the models attributes.

When you specify LIKE on a **CREATE** command, IMS sets the attributes of the newly created resource or descriptor to the models current attributes, except for the default attribute.

### DESC(descriptor\_name)

Specifies the name of the descriptor to use as a model to define this resource.

### RSC(resource\_name)

Specifies the name of the resource to use as a model to define this resource.

## **NAME**

Specifies the 1-8 character name of the database (DBD name). Names must be alphanumeric (A through Z, 0 through 9, #, \$, and @). All database names must begin with an alphabetic character (A through Z, #, \$, and @) followed by 0–7 alphanumeric characters. Names cannot include a blank, comma, period, hyphen, or equal sign. Names cannot begin with DFS, except for DFSIVPxx and DFSSAMxx. Names cannot be BASICEDT, DBCDM, DBRC, ISCEDT, MSDB, SDB, or WTOR. A database resource and a database descriptor can have the same name.

## **SET**

Specifies the attributes of the database to be created. If the LIKE keyword is omitted, attributes not specified take the value defined in the default descriptor, which is either IMS descriptor DFSDSDB1 or user-defined. If the LIKE keyword is specified, attributes not specified take the value defined in the model.

### **ACCTYPE()**

Specifies the access intent for the named database, which is how the subsystem requesting access plans to use the database. Access type is used with the database sharing level declared to DBRC. Access types include the following options:

#### **BRWS**

The database is available for read-only processing on this IMS subsystem. The only programs that can use the database on this subsystem are those that have a PCB processing option of GO (PROCOPT=GO). Programs that access the data using the GO processing option might see uncommitted data since a sharing IMS subsystem could be updating the database. The database is opened for read-only processing.

#### **EXCL**

The database is to be used exclusively by this IMS subsystem. This exclusive access is guaranteed only when the database is registered to DBRC.

#### **READ**

The database is available for read-only processing in this IMS subsystem. Programs with update intent can be scheduled, but cannot update the database. Access type READ differs from access type BRWS in that the data is read with integrity (locking is performed) and all programs can access the data, not just those with a processing option of GO. The database is opened for read-only processing.

#### **UPD**

The database is available for update as well as read processing in the IMS subsystem. This is the default.

## **RESIDENT**

Specifies the resident option. The RESIDENT(N) option takes effect immediately. The RESIDENT(Y) option takes effect at the next restart, unless the database was created as RESIDENT(Y) after the checkpoint from which this IMS is performing emergency restart. A database defined as a DEDB or an MSDB in ACBLIB always sets the RESIDENT(Y) attribute, regardless of the RESIDENT value specified.

### **N**

The DMB associated with the named database resource is not made resident in storage. The DMB is loaded at scheduling time.

### **Y**

The DMB associated with the named database resource is made resident in storage at the next IMS restart. At the next IMS restart, IMS loads the DMB and initializes it. A resident database is accessed from local storage, which eliminates I/O to the ACBLIB. In an online environment, the DMB control blocks are stored in the ACBLIB. If the DLI/SAS address space exists, DLI/SAS loads the DMB; otherwise, it is the IMS control region that loads it. This makes the DMB dependent on the existence of the corresponding database resource.

## Usage notes

The database can be HSAM, HISAM, HDAM, HIDAM, DEDB, MSDB, or a HALDB master database. Two database resources must be defined for a HIDAM database; one for the INDEX DBD, and one for the HIDAM DBD. No database resource should be defined for a PHIDAM primary index. One database must be defined for each secondary index that refers to any database defined to the online system. The database cannot be a HALDB partition. HALDB partitions can be defined using the HALDB Partition Definition utility.

A BLDL is performed on the DMB associated with this database. The database is created even if the DMB is not defined in ACBLIB. In this case, the database cannot be used. The database status is NOTINIT when a **/DISPLAY DB** or **QUERY DB** is issued for the database. Online Change must be used to add the DMB to ACBLIB, before the database can be used.

After a **CREATE DB** command for a HALDB master database, the user must issue a **QUERY DB** command or a **/DISPLAY DB** command for the HALDB master to determine if the partitions were built. If the partitions were not built, the user must issue one of the following commands to initialize the partitions:

- A **/START DB HALDB\_Master OPEN** command
- An **UPDATE DB NAME(HALDB\_Master) START(ACCESS) OPTION(OPEN)** command

Fast Path DEDB or MSDB-related control blocks are loaded.

If the DMB is in the ACBLIB library, IMS loads the DMB and can determine what type of database it is. IMS takes different actions depending on whether it is a full function database, a DEDB, or an MSDB.

- For full function databases, the DMB is loaded into the DMB pool. Even if the database is created with **RESIDENT(Y)**, DMB residency does not take effect until the next IMS restart.
- For DEDBs, the DMCB (DEDB version of a DMB), is chained into the DMCB chain (all DEDB DMCBs are resident). The parameters are then checked for CI size and to see whether the DMCB contains an area that already exists. If the CI size of any AREA is larger than the CI size specified for the DBBF buffers (fast path global buffer pool), then the **CREATE** command fails with completion code E3. If the DMCB contains an area definition that already exists in the FPAL (Fast Path Area List), the **CREATE** command fails with completion code E4.
- For MSDBs, a special procedure is required to make the MSDB available. The MSDB can then be used at the next IMS restart

If the DMB is not in the ACBLIB library, then the DDIR control block is successfully created, but has an initial status of NOTINIT.

Resources exist in IMS until they are deleted using a **DELETE** command. Resources are recoverable across an IMS warm start or emergency restart. Resources are lost if IMS is cold started, unless cold start imports definitions that were exported while IMS was up.

The **CREATE DB** command is similar to local online change (using a **/MODIFY** command) or global online change (using an **INITIATE OLC** command) for database resources in the MODBLKS data set, except that databases are added dynamically.

### Restrictions:

- The **CREATE DB** command can be issued only through the OM API.
- This command is not valid:
  - On the XRF alternate or FDBR region.
  - If online change for MODBLKS is enabled (DFSDfxxx or DFSCGxxx are defined with MODBLKS=OLC, or MODBLKS is not defined).

The **CREATE DB** command cannot be used to set a default Restricted Update (RREPL) value. You must use the **UPDATE DB** command to set a RREPL value for a newly created database.

## Output fields

The following table shows the **CREATE DB** output fields. The columns in the table are as follows:

**Short label**

Contains the short label generated in the XML output.

**Keyword**

Identifies keyword on the command that caused the field to be generated. N/A appears for output fields that are always returned. *error* appears for output fields that are returned only in case of an error.

**Meaning**

Provides a brief description of the output field.

*Table 114. Output fields for the CREATE DB command*

| Short label | Keyword      | Meaning   |
|-------------|--------------|---|
| CC          | N/A          | Completion code.  |
| CCTXT       | <i>error</i> | Completion code text that briefly explains the meaning of the non-zero completion code. |
| DB          | DB           | Database name.  |
| MBR         | N/A          | IMSplex member that built the output line.  |

**Return, reason, and completion codes**

The following table includes the return and reason codes and a brief explanation of the codes. The return or reason code returned for the command might also indicate an error from a CSL request.

*Table 115. Return and reason codes for CREATE DB*

| Return code | Reason code | Meaning   |
|-------------|-------------|---|
| X'00000000' | X'00000000' | Command completed successfully. The command output contains a line for each resource, accompanied by its completion code. See the completion code table for details.                                  |
| X'00000008' | X'00002048' | Invalid SET attribute.  |
| X'00000008' | X'00002117' | Invalid LIKE descriptor name.   |
| X'00000008' | X'00002118' | Invalid LIKE resource name.   |
| X'0000000C' | X'00003000' | Command was successful for some resources but failed for others. The command output contains a line for each resource, accompanied by its completion code. See the completion code table for details. |
| X'0000000C' | X'00003004' | Command was not successful for any of the resources. The command output contains a line for each resource, accompanied by its completion code. See the completion code table for details.             |
| X'00000010' | X'0000400C' | Command is not valid on the XRF alternate.  |
| X'00000010' | X'00004204' | Model is quiesced. Cannot quiesce the model.  |
| X'00000010' | X'00004120' | Online change phase is in progress.   |
| X'00000010' | X'00004300' | Command is not allowed because online change for MODBLKS is enabled (DFSDFxxx or DFSCGxxx defined with MODBLKS=OLC, or MODBLKS not defined).  |

Table 115. Return and reason codes for CREATE DB (continued)

| Return code | Reason code | Meaning  |
|-------------|-------------|--|
| X'00000010' | X'00004301' | Command is not allowed because the database is defined RESIDENT(Y), the DMB indicates there is a logical relationship for the database, but the other database is not defined.   |
| X'00000014' | X'00005004' | DFSOCMD response buffer could not be obtained.   |
| X'00000014' | X'00005008' | DFSPPOOL storage could not be obtained.  |
| X'00000014' | X'0000500C' | AWE could not be obtained.   |
| X'00000014' | X'00005010' | Unable to obtain latch.  |
| X'00000014' | X'00005114' | Resource or descriptor that is specified as a model is in the process of being imported from the change list in the IMSRSC repository or was not imported successfully from the change list at the end of IMS restart. This resource or descriptor cannot be referenced as a model on a <b>CREATE</b> command until it is successfully imported from the repository. |

Errors unique to the processing of this command are returned as completion codes. The following table includes an explanation of the completion codes.

Table 116. Completion codes for the CREATE DB command

| Completion code | Completion code text             | Meaning   |
|-----------------|----------------------------------|---|
| 0               |                                  | Command completed successfully for database.  |
| 11              | RESOURCE ALREADY EXISTS          | Database exists.  |
| 17              | ANOTHER CMD IN PROGRESS          | Quiescing the default descriptor failed because it was being referenced by another command.   |
| 5F              | INVALID CHARACTERS IN NAME       | Name is invalid because it contains an invalid character.   |
| 60              | GETMAIN STORAGE ERROR            | A GETMAIN request for storage was unsuccessful.   |
| 61              | DFSBCB STORAGE ERROR             | Request to get BCB storage for DDIR control block failed.   |
| 65              | DMB POOL STORAGE ERROR           | During a <b>CREATE</b> command for a DB resource, there was no storage available in the DMB pool to load a resident DMB.                    |
| 8A              | WILDCARD PARAMETER NOT SUPPORTED | The <b>CREATE</b> command does not support wildcard parameters. You must explicitly specify the names of the resources you want to create.  |
| 90              | INTERNAL ERROR                   | An IMS system service failure.  |
| 93              | RESERVED NAME                    | Name is reserved. For example, name starts with DFS (except for DFSSAMxx or DFSIVPxx), or is an IMS reserved name such as BASICEDT or WTOR. |



Table 116. Completion codes for the CREATE DB command (continued)

| Completion code | Completion code text             | Meaning  |
|-----------------|----------------------------------|--|
| BC              | MAX 32767 DB EXCEEDED            | The <b>CREATE DB</b> command failed, because it attempted to create the 32768th database. A maximum of 32,767 databases are allowed.         |
| DE              | ACBLIB READ FAILURE              | A read request for a member in ACBLIB failed.  |
| FA              | AREA SIZE GREATER THAN BUFF SIZE | A <b>CREATE</b> command for a DEDB failed because one of the areas in the DEDB has a buffer size greater than the system buffer size (BSIZ). |
| E4              | DUPLICATE AREA ALREADY EXISTS    | A <b>CREATE</b> command for a DEDB failed because one of the areas in the DEDB already exists.   |

## Examples

The following are examples of the **CREATE DB** command:

### Example 1 for CREATE DB command

TSO SPOC input:

```
CREATE DB NAME(DB000001,DB000002,DB000003) SET(ACCTYPE(UPD),RESIDENT(Y))
```

TSO SPOC output:

```
DBName  MbrName  CC
DB000001 IMS1      0
DB000002 IMS1      0
DB000003 IMS1      0
```

OM API input:

```
CMD(CREATE DB NAME(DB000001,DB000002,DB000003) SET(ACCTYPE(UPD),RESIDENT(Y)))
```

OM API output:

```
<imsout>
<ctl>
<omname>OM10M </omname>
<omvsn>1.3.0</omvsn>
<xmlvsn>20 </xmlvsn>
<statime>2006.254 23:22:04.212509</statime>
<stotime>2006.254 23:22:04.267816</stotime>
<staseq>BF6461C25FD1D8C5</staseq>
<stoseq>BF6461C26D528480</stoseq>
<rqsttkn1>USRT011 10162204</rqsttkn1>
<rc>00000000</rc>
<rsn>00000000</rsn>
</ctl>
<cmd>
<master>IMS1 </master>
<userid>USRT011 </userid>
<verb>CRE </verb>
<kwd>DB </kwd>
<input>CREATE DB NAME(DB000001,DB000002,DB000003)
SET(ACCTYPE(UPD),RESIDENT(Y)) </input>
</cmd>
<cmdisphdr>
```

```

<hdr slbl="DB" llbl="DBName" scope="LCL" sort="a" key="1" scroll="no"
  len="8" dtype="CHAR" align="left" />
<hdr slbl="MBR" llbl="MbrName" scope="LCL" sort="a" key="2" scroll="no"
  len="8" dtype="CHAR" align="left" />
<hdr slbl="CC" llbl="CC" scope="LCL" sort="n" key="0" scroll="yes"
  len="4" dtype="INT" align="right" skipb="no" />
<hdr slbl="CCTXT" llbl="CCText" scope="LCL" sort="n" key="0"
  scroll="yes" len="*" dtype="CHAR" skipb="yes" align="left" />
</cmdrsphdr>
<cmdrspdata>
<rsp>DB(DB000001) MBR(IMS1) CC( 0) </rsp>
<rsp>DB(DB000002) MBR(IMS1) CC( 0) </rsp>
<rsp>DB(DB000003) MBR(IMS1) CC( 0) </rsp>
</cmdrspdata>
</imsout>

```

TSO SPOC input:

```
QRY DB NAME(DB00*) SHOW(ACCTYPE,RESIDENT,DEFNTYPE,MODEL)
```

TSO SPOC output:

| DBName   | MbrName | CC TYPE | LAcc | Rsdnt | LRsdnt | ModelName | ModelType | DefnType |
|----------|---------|---------|------|-------|--------|-----------|-----------|----------|
| DB000001 | IMS1    | 0       | UPD  | Y     | N      | DFSDB1    | DESC      | CREATE   |
| DB000002 | IMS1    | 0       | UPD  | Y     | N      | DFSDB1    | DESC      | CREATE   |
| DB000003 | IMS1    | 0       | UPD  | Y     | N      | DFSDB1    | DESC      | CREATE   |

**Explanation:** Several databases are created dynamically, with an access type of update (UPD) and an attribute of resident. Attributes not specified on the command are set to the attributes defined in the database default descriptor. The **QRY DB** command displays the database attributes specified on the SHOW keyword. The database TYPE is shown as blank for both databases, since there is no DMB in ACBLIB and IMS cannot tell what the database type is. The resident attribute (Rsdnt) is shown as Y (yes), but the local resident attribute (Lrsdnt) is shown as N (no), since the resident attribute does not take effect until the next restart. The database default descriptor used to create the databases is shown as ModelName DFSDB1 and ModelType DESC for descriptor. The definition type Defntype is CREATE, since both of these databases were defined with a **CREATE** command.

### Related concepts

[How to interpret CSL request return and reason codes \(System Programming APIs\)](#)

### Related tasks

[Adding MSDB databases dynamically to an online IMS system \(Database Administration\)](#)

### Related reference

[“Command keywords and their synonyms” on page 59](#)

All IMS command keywords and their synonyms, as well as keywords supported by the OM API, are listed. The list covers command keywords for the OM command processing clients such as IMS, ODBM, IMSCON, and RM.

## CREATE DBDESC command

Use the **CREATE DBDESC** command to create database descriptors, which serve as models for creating database resources or other database descriptors.

A descriptor is created with a value set for every attribute.

Subsections:

- [“Environment” on page 183](#)
- [“Syntax” on page 183](#)
- [“Keywords” on page 183](#)
- [“Usage notes” on page 185](#)
- [“Output fields” on page 185](#)
- [“Return, reason, and completion codes” on page 186](#)

- “Examples” on page 187

## Environment

The following table lists the environments (DB/DC, DBCTL, and DCCTL) in which you can use the command and keywords.

Table 117. Valid environments for the CREATE DBDESC command and keywords

| Command / Keywords   | DB/DC | DBCTL | DCCTL |
|----------------------|-------|-------|-------|
| <b>CREATE DBDESC</b> | X     | X     |       |
| LIKE                 | X     | X     | X     |
| NAME                 | X     | X     | X     |
| SET                  | X     | X     | X     |

## Syntax

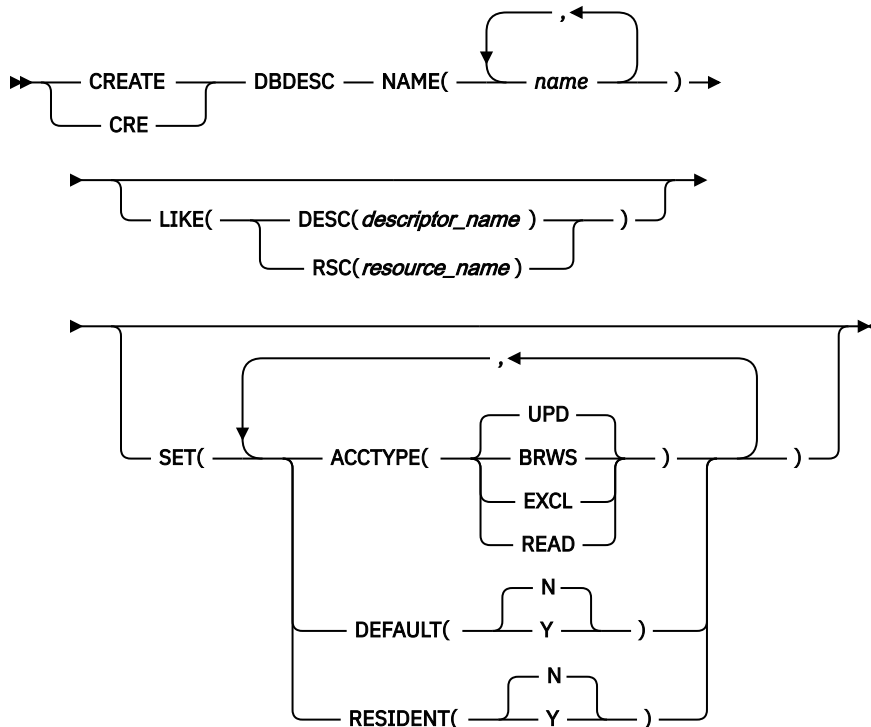

Default values shown in this syntax diagram reflect the default values that are defined in the IMS database descriptor, DFSDSDB1. If you define another descriptor as the default with a **CREATE** or **UPDATE DBDESC** command, the default values shown in this syntax diagram might not match the value defined in the current default descriptor.

## Keywords

The following keywords are valid for the **CREATE DBDESC** command:

### LIKE

Specifies that the descriptor is created using an existing descriptor as a model, instead of the default descriptor. The default descriptor is either the IMS descriptor DFSDSDB1, or user-defined. The model

type can either be a descriptor (DESC), or a resource (RSC). The descriptor is created with all the same attributes as the model, except for the DEFAULT(Y) value. Attributes set explicitly by the **CREATE** command override the model attributes. DEFAULT(Y) must be specified explicitly to make a descriptor the default descriptor. Later changes to the model are not propagated to resources or descriptors that were created from it.

Use **QUERY** commands to display the model name and model type used to create the descriptor. The model name and type returned from the **QUERY** command are provided for informational purposes only. The **EXPORT** command exports a resource definition including the model name and model type to the definition member. The **IMPORT** command imports a resource definition including the model name and model type from the definition member. An **IMPORT** command that creates a resource saves the model name and model type, but does not use the model's attributes.

When you specify LIKE on a **CREATE** command, IMS uses the model's current attributes to set the attributes of the newly-created descriptor, except for the default attribute.

**DESC(descriptor\_name)**

Specifies the name of the descriptor to use as a model to define this descriptor.

**RSC(resource\_name)**

Specifies the name of the resource to use as a model to define this descriptor.

**NAME**

Specifies the 1-8 character name of the database descriptor. Names must be alphanumeric (A through Z, 0 through 9, #, \$, and @). All database descriptor names must begin with an alphabetic character (A through Z, #, \$, and @) followed by 0–7 alphanumeric characters. Names cannot include a blank, comma, period, hyphen, or equal sign. Names cannot begin with DFS, except for DFSIVPxx and DFSSAMxx. Names cannot be BASICEDT, DBCDM, DBRC, ISCEDT, MSDB, SDB, or WTOR. A database resource and a database descriptor can have the same name.

**SET**

Specifies the attributes of the database to be created. If the LIKE keyword is omitted, attributes not specified take the value defined in the default descriptor, which is either IMS descriptor DFSDSDB1 or user-defined. If the LIKE keyword is specified, attributes not specified take the value defined in the model.

**ACCTYPE()**

Specifies the access intent for the named database, which is how the subsystem requesting access plans to use the database. Access type is used in conjunction with the database sharing level declared to DBRC.

**UPD**

The database is available for update as well as read processing in the IMS subsystem. This is the default.

**BRWS**

The database is available for read-only processing on this IMS subsystem. The only programs that can use the database on this subsystem are those that have a PCB processing option of GO (PROCOPT=GO). Programs that access the data using the GO processing option might see uncommitted data since a sharing IMS subsystem could be updating the database. The database is opened for read-only processing.

**EXCL**

The database is to be used exclusively by this IMS subsystem. This exclusive access is guaranteed only when the database is registered to DBRC.

**READ**

The database is available for read-only processing in this IMS subsystem. Programs with update intent can be scheduled, but cannot update the database. Access type READ differs from access type BRWS in that the data is read with integrity (locking is performed) and all programs can access the data, not just those with a processing option of GO. The database is opened for read-only processing.

**DEFAULT**

Specifies whether the descriptor is the default.

**N**

The descriptor is not the default.

**Y**

The descriptor is the default, which resets the existing default descriptor to DEFAULT(N). When a descriptor is created without the LIKE keyword, any attribute not specified on the **CREATE** command takes the value defined in the default descriptor. Only one descriptor can be defined as the default for a resource type. IMS defines a default database descriptor called DFSDSDB1, where all attributes are defined with the default value. Defining a user-defined descriptor as the default overrides the IMS-defined descriptor. Since only one database descriptor can be the default at one time, only one database name may be specified with DEFAULT(Y).

### **RESIDENT**

Specifies the resident option. The RESIDENT(N) option takes effect right away. The RESIDENT(Y) option takes effect at the next restart, unless the database was created as RESIDENT(Y) after the checkpoint from which this IMS is performing emergency restart. A database defined as a DEDB in ACBLIB always sets the RESIDENT(Y) attribute when the DEDB is loaded, regardless of the RESIDENT value specified. RESIDENT(N) is rejected for a DEDB

**N**

The DMB associated with the named database resource is not made resident in storage. The DMB is loaded at scheduling time.

**Y**

The DMB associated with the named database resource is made resident in storage at the next IMS restart. At the next IMS restart, IMS loads the DMB and initializes it. A resident database is accessed from local storage, which eliminates I/O to the ACBLIB. In an online environment, the DMB control blocks are stored in the ACBLIB. If the DLI/SAS address space exists, DLI/SAS loads the DMB; otherwise, it is the IMS control region that loads it. This makes the DMB dependent on the existence of the corresponding database resource.

## **Usage notes**

Attributes not explicitly specified on the **CREATE** command take the default value. Any database resource or descriptor can be created using this descriptor as a model, by specifying the **CREATE** command with LIKE(DESC(descriptor\_name)).

Descriptors exist for the life of the IMS unless they are deleted using a **DELETE** command. The descriptors are recoverable across an IMS warm start or emergency restart. Descriptors are lost if IMS is cold started, unless cold start imports definitions that were exported while IMS was up.

The **CREATE DBDESC** command can only be issued through the Operations Manager API. This command applies to DB/DC and DBCTL systems.

This command is not valid on the XRF alternate or FDBR region. The **CREATE DBDESC** command is not valid if online change for MODBLKS is enabled (DFSDFxxx or DFSCGxxx defined with MODBLKS=OLC or MODBLKS not defined).

## **Output fields**

The following table shows the **CREATE DBDESC** output fields. The columns in the table are as follows:

### **Short label**

Contains the short label generated in the XML output.

### **Keyword**

Identifies keyword on the command that caused the field to be generated. N/A appears for output fields that are always returned. *error* appears for output fields that are returned only in case of an error.

## Meaning

Provides a brief description of the output field.

Table 118. Output fields for the CREATE DBDESC command

| Short label | Keyword      | Meaning  |
|-------------|--------------|--|
| CC          | N/A          | Completion code.   |
| CCTXT       | <i>error</i> | Completion code text that briefly explains the meaning of the non-zero completion code.  |
| DESC        | DBDESC       | Database descriptor name.  |
| MBR         | N/A          | IMSplex member that built the output line.   |
| OLDDEF      | DBDESC       | Old default descriptor name, if this descriptor is made the default by specifying DEFAULT(Y). The old default descriptor is no longer the default. |

## Return, reason, and completion codes

The following table includes the return and reason codes and a brief explanation of the codes. The return or reason code returned for the command might also indicate an error from a CSL request.

Table 119. Return and reason codes for CREATE DBDESC

| Return code | Reason code | Meaning   |
|-------------|-------------|---|
| X'00000000' | X'00000000' | Command completed successfully. The command output contains a line for each descriptor, accompanied by its completion code. See the completion code table for details.                                    |
| X'00000008' | X'00002048' | Invalid SET attribute.  |
| X'00000008' | X'00002117' | Invalid LIKE descriptor name.   |
| X'00000008' | X'00002118' | Invalid LIKE resource name.   |
| X'00000008' | X'00002133' | Multiple name parameters specified with DEFAULT(Y) is invalid. Only one descriptor may be the default at one time.  |
| X'0000000C' | X'00003000' | Command was successful for some descriptors but failed for others. The command output contains a line for each descriptor, accompanied by its completion code. See the completion code table for details. |
| X'0000000C' | X'00003004' | Command was not successful for any of the descriptors. The command output contains a line for each descriptor, accompanied by its completion code. See the completion code table for details.             |
| X'00000010' | X'0000400C' | Command is not valid on the XRF alternate.  |
| X'00000010' | X'00004120' | Online change phase is in progress.   |
| X'00000010' | X'00004204' | Model is quiesced. Cannot quiesce model.  |
| X'00000010' | X'00004300' | Command is not allowed because online change for MODBLKS is enabled (DFSDFxxx or DFSCGxxx defined with MODBLKS=OLC, or MODBLKS not defined).  |

Table 119. Return and reason codes for CREATE DBDESC (continued)

| Return code | Reason code | Meaning  |
|-------------|-------------|--|
| X'00000010' | X'00004301' | Command is not allowed because the database is defined RESIDENT(Y), the DMB indicates there is a logical relationship for the database, but the other database is not defined.   |
| X'00000014' | X'00005004' | DFSOCMD response buffer could not be obtained.   |
| X'00000014' | X'00005008' | DFSPPOOL storage could not be obtained.  |
| X'00000014' | X'0000500C' | AWE could not be obtained.   |
| X'00000014' | X'00005010' | Unable to obtain latch.  |
| X'00000014' | X'00005114' | Resource or descriptor that is specified as a model is in the process of being imported from the change list in the IMSRSC repository or was not imported successfully from the change list at the end of IMS restart. This resource or descriptor cannot be referenced as a model on a <b>CREATE</b> command until it is successfully imported from the repository. |

Errors unique to the processing of this command are returned as completion codes. The following table includes an explanation of the completion codes.

Table 120. Completion codes for the CREATE DBDESC command

| Completion code | Completion code text             | Meaning  |
|-----------------|----------------------------------|--|
| 0               |                                  | Command completed successfully for database descriptor.  |
| 11              | RESOURCE ALREADY EXISTS          | Database descriptor already exists.  |
| 17              | ANOTHER CMD IN PROGRESS          | Quiescing the default descriptor failed because it was being referenced by another command.  |
| 5F              | INVALID CHARACTERS IN NAME       | Name is invalid because it contains an invalid character.  |
| 60              | GETMAIN STORAGE ERROR            | A GETMAIN request for storage was unsuccessful.  |
| 61              | DFSBCB STORAGE ERROR             | Request to get BCB storage for DDIR control block failed.  |
| 8A              | WILDCARD PARAMETER NOT SUPPORTED | You must explicitly specify the names of the descriptors you want to create. The <b>CREATE</b> command does not support wildcard parameters. |
| 90              | INTERNAL ERROR                   | An IMS system service failure.   |
| 93              | RESERVED NAME                    | Name is reserved. For example, name starts with DFS (except for DFSSAMxx or DFSIVPxx), or is an IMS reserved name such as BASICEDT or WTOR.  |

## Examples

The following are examples of the **CREATE DBDESC** command:

### **Example 1 for CREATE DBDESC command**

In this example, the database descriptors listed in the command with the NAME keyword are created with update access. Attributes not specified on the command are assigned the system defaults.

TSO SPOC input:

```
CREATE DBDESC NAME (DBHDAM1, DBHDAM2, DBHDAM3, DBHDAM4) SET (ACCTYPE (UPD))
```

TSO SPOC output:

```
DBName  MbrName  CC
DBHDAM1  IMS1      0
DBHDAM2  IMS1      0
DBHDAM3  IMS1      0
DBHDAM4  IMS1      0
```

### **Related concepts**

[How to interpret CSL request return and reason codes \(System Programming APIs\)](#)

### **Related reference**

[“Command keywords and their synonyms” on page 59](#)

All IMS command keywords and their synonyms, as well as keywords supported by the OM API, are listed. The list covers command keywords for the OM command processing clients such as IMS, ODBM, IMSCON, and RM.

## **CREATE IMSCON commands**

---

Use the **CREATE IMSCON** commands to add IMS Connect port or data store definitions during runtime processing without having to restart your IMS Connect instance.

The TYPE keyword specifies the type of IMS Connect resource to create.

The **CREATE IMSCON** command is processed by every IMS Connect to which OM routes the command, whether or not OM has designated a particular IMS Connect as the command master.

Subsections:

- [“CREATE IMSCON TYPE\(DATASTORE\) command” on page 188](#)
- [“CREATE IMSCON TYPE\(IMSPLEX\) command” on page 198](#)
- [“CREATE IMSCON TYPE\(PORT\) command” on page 204](#)

### **Related reference**

[IMS Connect type-2 commands \(Commands\)](#)

[HWSCFGxx member of the IMS PROCLIB data set \(System Definition\)](#)

## **CREATE IMSCON TYPE(DATASTORE) command**

Use the **CREATE IMSCON TYPE (DATASTORE)** command to add IMS Connect data store definitions during runtime processing without having to restart your IMS Connect instance.

The **CREATE IMSCON TYPE (DATASTORE)** command is used to add a communications path to an IMS data store from IMS Connect.

You can also create data store definitions by specifying the DATASTORE statement in the HWSCFGxx member of the IMS PROCLIB data set.

Subsections:

- [“Environment” on page 189](#)
- [“Syntax” on page 189](#)
- [“Keywords” on page 190](#)



- [“Usage notes” on page 194](#)
- [“Equivalent WTOR and z/OS commands” on page 194](#)
- [“Output fields” on page 194](#)
- [“Return, reason, and completion codes” on page 195](#)
- [“Return, reason, and completion codes handled by OM” on page 196](#)
- [“Examples” on page 196](#)

## Environment

The **CREATE IMSCON** command is applicable only to IMS Connect. To issue this command, the following conditions must be satisfied:

- IMS Connect must be active and configured to communicate with the Common Service Layer (CSL) Structured Call Interface (SCI).
- A type-2 command environment with Structured Call Interface (SCI) and Operations Manager (OM) must be active.

## Syntax

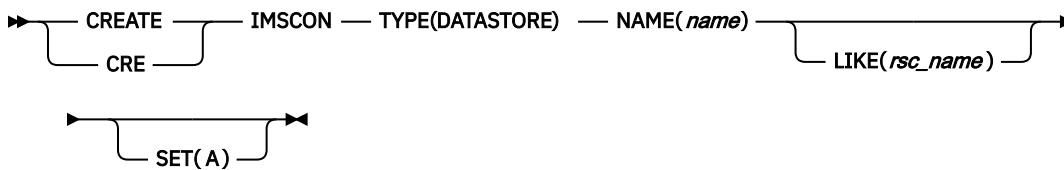

**A**

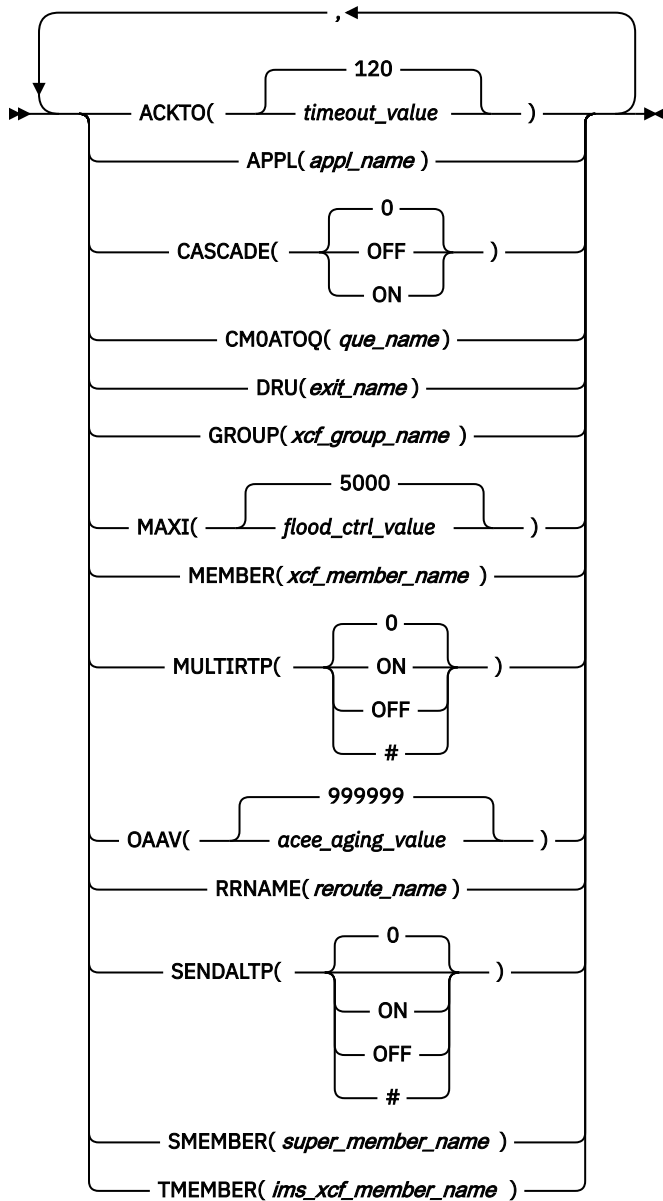

## Keywords

The following keywords are valid for the **CREATE IMSCON TYPE(DATASTORE)** command:

### LIKE

Specifies the existing IMS Connect data store to use as a model. The new resource is created with all of the same attribute values as the specified model data store.

Attributes that are set explicitly by the **CREATE IMSCON TYPE(DATASTORE)** command override the attribute values that are generated from the model. Later changes to the model are not propagated to resources that were created from it.

### NAME

Specifies the 1- to 8-character name of the IMS data store. The name can consist of alphanumeric characters and must be unique within IMS Connect.

This keyword is equivalent to the ID parameter of the DATASTORE statement in the HWSCFGxx member of the IMS PROCLIB data set.

This parameter is required.

## **SET**

Specifies the attributes of the IMS data store to be created.

If the LIKE keyword is omitted, the required attributes must be specified. If an optional attribute is not specified, IMS Connect uses its default value.

If the LIKE keyword is specified, the attribute values that are specified with the SET keyword override the values that are generated from the model.

## **ACKTO**

Specifies the timeout interval for acknowledgements to OTMA for CM0 and CM1 output messages and for IMS-to-IMS transaction messages. The timeout value can be 0 - 255 seconds.

This parameter is optional and defaults to 120. If the timeout value is 0 or is not specified, the OTMA ACK timeout default value of 120 seconds is set.

For IMS-to-IMS transaction messages, if an acknowledgement is not received by OTMA before the timeout interval expires, OTMA reroutes the transaction message to the timeout queue, DFS\$ \$TOQ.

## **APPL**

Specifies the 1- to 8-character alphanumeric TCP/IP APPL name defined to RACF in the PTKTDATA statement.

This parameter is optional and defaults to blanks. If you are using PassTicket and user message exits, you must specify the APPL parameter.

## **CASCADE=**

For this data store connection only, enables or disables support for the cascading of global, two-phase commit (synclevel=syncpoint) z/OS Resource Recovery Services transactions from IMS TM Resource Adapter via a TCP/IP connection to an IMS TM or IMS DB/DC system that is on a different z/OS image (LPAR) than IMS Connect. Cascading transactions that are received via a LOCAL option connection is not supported.

The CASCADE parameter applies only to the support for cascading global, RRS transactions between IMS Connect and IMS TM when they are on different z/OS images. The specification of the IMS Connect CASCADE parameter does not affect support between other components or subsystems, such as between IMS subsystems in a shared queues environment.

The CASCADE specification in the definition of a data store connection overrides the value of CASCADE that is in effect for the IMS Connect system.

Until the next restart of IMS Connect, a CASCADE specification made by the **UPDATE IMSCON TYPE (DATASTORE) SET(CASCADE())** command overrides the CASCADE specification on the DATASTORE configuration statement.

## **0**

When the LIKE keyword is used to create a data store connection by copying the attributes of an existing data store connection, the numerical character "0" omits the CASCADE specification from the copied attributes. If CASCADE=0 is specified when the LIKE keyword is not used, the result is the same as omitting the CASCADE keyword. In either case, the resulting data store connection inherits the CASCADE value that is in effect for the IMS Connect system configuration.

CASCADE(0) is the default.

## **OFF**

Disables support for cascading of global, two-phase commit (synclevel=syncpoint) RRS transactions to an IMS TM or IMS DB/DC system that is running on a different LPAR than IMS Connect. If a synclevel=syncpoint transaction is routed to an IMS system that resides on a different LPAR than IMS Connect, IMS Connect rejects the transaction with return code 4 and reason code NCASCADE.

When support is disabled, you can send a synclevel=syncpoint transaction to IMS on this data store connection only if IMS Connect and IMS reside on the same LPAR.

**ON**

Enables support for cascading of global, two-phase commit (synclevel=syncpoint) RRS transactions to an IMS TM or IMS DB/DC system that is running on different LPAR than IMS Connect.

IMS Connect detects whether the IMS system is on the same LPAR. If IMS Connect and IMS are running on different LPARs, two-phase commit processing uses cascaded transactions. If IMS Connect and IMS are running on the same LPAR, two-phase commit processing does not use cascaded transactions.

**CMOATOQ**

Specifies the 1- to 8-character alphanumeric name for the OTMA CMO ACK timeout queue.

The value that is specified here overrides both the OTMA default value of DFS\$\$TOQ and the value that is set in the HWS statement of the HWSCFGxx member of the IMS PROCLIB data set.

This parameter is optional and defaults to blanks.

**DRU**

Specifies the 1- to 8-character alphanumeric name for the OTMA destination resolution user (DRU) exit that is passed to OTMA. The DRU exit is required to support asynchronous output to IMS Connect clients.

This parameter is optional and defaults to DFSYDRU0.

**GROUP**

Specifies the 1- to 8-character alphanumeric name of the z/OS cross-system coupling facility (XCF) group for the IMS OTMA. IMS Connect uses this value to join the XCF group.

Because IMS Connect and IMS must be in the same XCF group to communicate, this group name must match the XCF group name that you define to IMS (*GRNAME*) in the IMS startup JCL (for example, "OTMA=Y,GRNAME=&GROUP,USERVAR=&MEMBER",...).

This parameter is required if the LIKE keyword is not specified.

**MAXI**

Specifies the OTMA input message flood control value. The valid range is 0 - 9999.

If you specify a value of 0, the OTMA default value of 5000 is used.

If you specify a value 1 - 200, the OTMA minimum value of 200 is used.

This parameter is optional and defaults to 5000.

**MEMBER**

Specifies the 1- to 16-character alphanumeric XCF member name that identifies IMS Connect in the XCF group that is specified by the GROUP parameter.

This name is the XCF name that IMS uses to communicate with IMS Connect in that XCF group. This XCF member name for IMS Connect must be unique in the data store definitions for all data stores that are members of the same XCF group.

This parameter is required.

**MULTIRTP**

Specifies whether IMS Connect requests an OTMA tpipe that supports multiple active resume tpipe requests (MULTIRTP) when IMS Connect establishes the DATASTORE connection with the IMS data store.

Any specified MULTIRTP value other than 0 overrides the MULTIRTP value that is in effect for the IMS Connect system configuration. To accept the MULTIRTP value that is in effect for the IMS Connect system configuration, omit the MULTIRTP parameter or specify MULTIRTP=(0), which is the default.

The following values are valid on the MULTIRTP keyword:

**0**

Specifies that the MULTIRTP value for this data store connection is determined by the IMS Connect system configuration. If the IMS Connect system does not specify a MULTIRTP value,

the OTMA client descriptor determines whether the tpipes for this data store connection support multiple active resume tpipe requests.

**#**

Specifies that the OTMA client descriptor determines the MULTIRTP value for this data store connection.

**OFF**

Disables support for multiple active resume tpipe requests on tpipes for this data store connection.

**ON**

Enables support for multiple active resume tpipe requests on tpipes for this data store connection.

**OAAV**

Specifies the decimal integer that defines the OTMA accessor environment element (ACEE) aging value, in seconds, for this IMS data store.

When the OTMA ACEE aging value is reached, OTMA refreshes the ACEE before it processes the next input message that is received from IMS Connect.

Valid values are 0 - 999999. If you specify 0, OTMA uses the default value of 999999. If you specify a value 1 - 300, OTMA uses a value of 300 seconds.

This parameter is optional and defaults to 999999.

**RRNAME**

Specifies the 1- to 8-character alphanumeric name of the alternative destination of a client reroute request. The name can consist of alphanumeric characters (A – Z, 0 – 9) and special characters (@, #, \$). IMS Connect translates lowercase characters to uppercase characters.

This parameter is optional and defaults to HWS\$DEF.

**SENDALTP**

Specifies whether the ALTPCB output is sent back to the originating IMS Connect client for commit-then-send send-receive transactions for the data store connection.

If the SENDALTP value specified is not 0, it overrides the SENDALTP value in the IMS Connect system configuration. If you want to use the SENDALTP value that is in effect for the IMS Connect system configuration, remove the SENDALTP parameter or specify SENDALTP=(0), which is the default.

The following values are valid on the SENDALTP parameter:

**0**

Specifies that the SENDALTP specification is removed from the definition of the data store connection. The SENDALTP value for this data store connection is determined by the IMS Connect system configuration.

If the IMS Connect system does not specify a SENDALTP value, the OTMA client descriptor determines it for this data store connection.

**#**

Specifies that the OTMA client descriptor determines the SENDALTP value for this data store connection.

**OFF**

Disables support for sending the ALTPCB output to the originating IMS Connect client.

**ON**

Enables support for sending the ALTPCB output to the originating IMS Connect client that submits commit-then-send send-receive calls.

**SMEMBER**

Specifies the 1-4 character name of the OTMA super member to which this IMS data store belongs.

If specified, this value overrides the attribute values for the SMEMBER parameter in the HWS statement of the HWSCFGxx member of the IMS PROCLIB data set.

To disable the value of SMEMBER specified on this IMS data store, specify the parameter with no value, for example, SMEMBER( ).

This parameter is optional and defaults to blanks.

#### **TMEMBER**

Specifies the 1- to 16-character alphanumeric XCF member name of the IMS that this IMS Connect communicates with in the XCF group.

This target member name must match the member name that IMS uses when it joins the XCF group. The XCF member name for IMS is specified in the IMS startup JCL (for example, “. . . , OTMA=Y , GRNAME=&GROUP , OTMANM=&TMEMBER , . . .”).

This parameter is required if the LIKE keyword parameter is not specified.

## **Usage notes**

You can issue the **CREATE IMSCON TYPE(DATASTORE)** command only through the Operations Manager (OM) API.

IMS Connect can process IMS Connect type-2 commands only if the IMSplex from which the commands were issued has a status of ACTIVE.

When a keyword is specified without any value, that keyword is ignored. IMS Connect processes the command as if the keyword were not specified.

At the completion of the **CREATE IMSCON TYPE(DATASTORE)** command, IMS Connect starts the IMS data store and sets the IMS data store status to CONNECT if it is successful and DISCONNECT if it is not successful.

IMS Connect resources that are created by use of this command are not saved across restarts of IMS Connect, unless a corresponding configuration statement is also added to the HWSCFGxx member of the IMS PROCLIB data set before the next restart.

## **Equivalent WTOR and z/OS commands**

Equivalent WTOR and z/OS commands that perform similar functions as the **CREATE IMSCON TYPE(DATASTORE)** command are not available.

## **Output fields**

The following table shows the **CREATE IMSCON TYPE(DATASTORE)** output fields. The following is a list of the columns that are available in the table:

#### **Short label**

Contains the short label that is generated in the XML output.

#### **Long label**

Contains the column heading for the output field in the formatted output.

#### **Keyword**

Identifies the keyword on the command that caused the field to be generated. N/A is displayed for output fields that are always returned. For output fields that are returned only in case of an error, error is displayed.

#### **Meaning**

Provides a brief description of the output field.

Table 121. Output fields for the CREATE IMSCON TYPE(DATASTORE) command

| Short label | Long label | Keyword | Meaning  |
|-------------|------------|---------|--|
| CC          | CC         | N/A     | Completion code that indicates whether IMS Connect was able to process the command for the specified resource. The completion code is always returned. |
| CCTXT       | CCText     | N/A     | Completion code text that briefly explains the meaning of the nonzero completion code. This field is returned only for an error completion code.       |
| DS          | DataStore  | N/A     | The data store name. The data store name is always returned.   |
| MBR         | MbrName    | N/A     | Identifier of the IMS Connect that built the output line. The identifier is always returned.   |

## Return, reason, and completion codes

An IMS Connect return and reason code is returned to OM by the **CREATE IMSCON TYPE(DATASTORE)** command. The OM return and reason codes that might be returned as a result of the **CREATE IMSCON TYPE(DATASTORE)** command are standard for all commands that are entered through the OM API.

The following table includes the return and reason codes and a brief explanation of the codes. The return or reason code returned for the command might also indicate an error from a CSL request.

Table 122. Return and reason codes for the CREATE IMSCON TYPE(DATASTORE) command

| Return code | Reason code | Meaning  |
|-------------|-------------|--|
| X'00000000' | X'00000000' | The command completed successfully. The command output contains a line for each resource, which is accompanied by its completion code. See the completion codes table for details. |
| X'0C000008' | X'00002010' | Wildcards (* and %) are not supported.   |
| X'0C000008' | X'00002018' | The required NAME parameter is not specified.  |
| X'0C000008' | X'00002024' | The LIKE keyword parameter value is invalid. The resource cannot be found.   |
| X'0C000008' | X'0000202C' | The resource already exists.   |
| X'0C000008' | X'0000204C' | The required GROUP parameter is not specified.   |
| X'0C000008' | X'00002050' | The required MEMBER parameter is not specified.  |
| X'0C000008' | X'00002054' | The required TMEMBER parameter is not specified.   |
| X'0C000008' | X'0000207C' | The MEMBER parameter value is a duplicate of an existing DATASTORE MEMBER value.   |
| X'0C000008' | X'00002133' | Multiple NAME parameter values are not allowed.  |
| X'0C00000C' | X'00003000' | The command was successful for some resources but failed for others. The command output contains a line for each resource, which is accompanied by its completion code.            |
| X'0C00000C' | X'00003004' | The command was not successful for any resource. The command output contains a line for each resource, which is accompanied by its completion code.                                |

Table 122. Return and reason codes for the CREATE IMSCON TYPE(DATASTORE) command (continued)

| Return code | Reason code | Meaning   |
|-------------|-------------|---|
| X'0C000014' | X'00005000' | IMS Connect encountered an error while attempting to obtain a block of storage from the BPECBGET service. |

The following table includes an explanation of the completion codes. Errors unique to the processing of this command are returned as completion codes. A completion code is returned for each action against an individual resource.

Table 123. Completion codes for the CREATE IMSCON TYPE(DATASTORE) command

| Completion code | Completion code text           | Meaning  |
|-----------------|--------------------------------|--|
| 0               |                                | The <b>CREATE IMSCON TYPE(DATASTORE)</b> command completed successfully.   |
| 13              | The resource already exists.   | The data store already exists.   |
| 3C              | Resource created, start failed | <p>The <b>CREATE</b> command has created the definition of the requested resource in IMS Connect, but the resource failed to start.</p> <p>The command output might also contain one of the following messages, which describe why the resource failed to start:</p> <ul style="list-style-type: none"> <li>• HWSO1205W</li> <li>• HWSO1210W</li> <li>• HWSO1215W</li> <li>• HWSO1220W</li> <li>• HWSO1305W</li> <li>• HWSO1310W</li> <li>• HWSO1315W</li> <li>• HWSO1320W</li> <li>• HWSO1325W</li> </ul> |

## Return, reason, and completion codes handled by OM

IMS Connect registers its type-2 command set with OM. When OM detects a command parsing error, OM returns a return code and reason code to the requester, and the command is not routed to IMS Connect.

Clients such as the TSO SPOC send commands to OM by using the CSLOMCMD API. CSLOMCMD return and reason codes are listed in the description of the CSLOMCMD request.

### Examples

The following are examples of the **CREATE IMSCON TYPE(DATASTORE)** command:

#### Example 1 for CREATE IMSCON TYPE(DATASTORE) command

TSO SPOC input:



```
CREATE IMSCON TYPE(DATASTORE) NAME(IMS2)
SET(GROUP(XCFGRP1),MEMBER(ICON1),TMEMBER(IMS2))
```

TSO SPOC output:

| DataStore | MbrName | CC |
|-----------|---------|----|
| IMS2      | HWS1    | 0  |

OM API input:

```
CMD(CRE IMSCON TYPE(DATASTORE) NAME(IMS2)
SET(GROUP(XCFGRP1),MEMBER(ICON1),TMEMBER(IMS2)))
```

OM API output:

```
<?xml version="1.0"?>
<!DOCTYPE imsout SYSTEM "imsout.dtd">
<imsout>
<ctl>
<omname>OM10M </omname>
<omvsn>1.6.0</omvsn>
<xmlvsn>20 </xmlvsn>
<statime>2012.314 00:31:32.035293</statime>
<stotime>2012.314 00:31:32.035883</stotime>
<staseq>CA7155B83AADD297</staseq>
<stoseq>CA7155B83AD2B797</stoseq>
<rqsttkn1>USRT011 10163132</rqsttkn1>
<rc>00000000</rc>
<rsn>00000000</rsn>
</ctl>
<cmd>
<master>HWS1 </master>
<userid>USRT011 </userid>
<verb>CRE </verb>
<kwd>IMSCON </kwd>
<input>CREATE IMSCON TYPE(DATASTORE) NAME(IMS2) SET(GROUP(XCFGRP1),MEMBER(ICON1),
TMEMBER(IMS2)) </input>
</cmd>
<cmdrsphdr>
<hdr slbl="DS" llbl="DataStore" scope="LCL" sort="a" key="1" scroll="no" len="8"
dtype="CHAR" align="left" skipb="no" />
<hdr slbl="MBR" llbl="MbrName" scope="LCL" sort="a" key="2" scroll="no" len="8"
dtype="CHAR" align="left" skipb="no" />
<hdr slbl="CC" llbl="CC" scope="LCL" sort="n" key="0" scroll="yes" len="4"
dtype="INT" align="right" skipb="no" />
<hdr slbl="CCTXT" llbl="CCText" scope="LCL" sort="n" key="0" scroll="yes" len="32"
dtype="CHAR" align="left" skipb="yes" />
</cmdrsphdr>
<cmdrspdata>
<rsp>DS(IMS2 ) MBR(HWS1 ) CC( 0) </rsp>
</cmdrspdata>
</imsout>
```

**Explanation:** Data store IMS2 is created with the specified attributes.

### Example 2 for CREATE IMSCON TYPE(DATASTORE) command

TSO SPOC input:

```
CREATE IMSCON TYPE(DATASTORE) NAME(IMS2) LIKE(IMS1)
SET(GROUP(XCFGRP1),MEMBER(ICON1B),TMEMBER(IMS2),ACKTO(60),
SMEMBER(SM02))
```

TSO SPOC output:

| DataStore | MbrName | CC |
|-----------|---------|----|
| IMS2      | HWS1    | 0  |

OM API input:

```
CMD(CRE IMSCON TYPE(DATASTORE) NAME(IMS2) LIKE(IMS1)
SET(GROUP(XCFGRP1),MEMBER(ICON1B),TMEMBER(IMS2),ACKTO(60),
SMEMBER(SM02)))
```

## OM API output:

```
<?xml version="1.0"?>
<!DOCTYPE imsout SYSTEM "imsout.dtd">
<imsout>
<ctl>
<omname>OM10M </omname>
<omvsn>1.6.0</omvsn>
<xmlvsn>20 </xmlvsn>
<statime>2012.314 00:55:31.481740</statime>
<stotime>2012.314 00:55:31.482361</stotime>
<staseq>CA715B14FE08C99D</staseq>
<stoseq>CA715B14FE2F921D</stoseq>
<rqsttkn1>USRT011 10165531</rqsttkn1>
<rc>00000000</rc>
<rsn>00000000</rsn>
</ctl>
<cmd>
<master>HWS1 </master>
<userid>USRT011 </userid>
<verb>CRE </verb>
<kwd>IMSCON </kwd>
<input>CREATE IMSCON TYPE(DATASTORE) NAME(IMS2) LIKE(IMS1) SET(GROUP(XCFGPR1),
MEMBER(ICON1B),TMEMBER(IMS2),ACKTO(60),
SMEMBER(SM02)) </input>
</cmd>
<cmdsphdr>
<hdr slbl="DS" llbl="DataStore" scope="LCL" sort="a" key="1" scroll="no" len="8"
dtype="CHAR" align="left" skipb="no" />
<hdr slbl="MBR" llbl="MbrName" scope="LCL" sort="a" key="2" scroll="no" len="8"
dtype="CHAR" align="left" skipb="no" />
<hdr slbl="CC" llbl="CC" scope="LCL" sort="n" key="0" scroll="yes" len="4"
dtype="INT" align="right" skipb="no" />
<hdr slbl="CCTXT" llbl="CCText" scope="LCL" sort="n" key="0" scroll="yes" len="32"
dtype="CHAR" align="left" skipb="yes" />
</cmdsphdr>
<cmdsdata>
<rsp>DS(IMS2) MBR(HWS1) CC(0) </rsp>
</cmdsdata>
</imsout>
```

**Explanation:** Data store IMS2 is created with the same attribute values as data store IMS1. However, the GROUP, MEMBER, TMEMBER, ACKTO, and SMEMBER attributes are also specified, and their values override the values from the IMS1 data store model.

### Related reference

[CSL0MCMD: command request \(System Programming APIs\)](#)

[IMSPLEX statement \(System Definition\)](#)

[DATASTORE statement \(System Definition\)](#)

## CREATE IMSCON TYPE(IMSPLEX) command

Use the **CREATE IMSCON TYPE (IMSPLEX)** command to add a communications path from IMS Connect to an IMSplex through a Structured Call Interface (SCI) for communications to other members in the IMSplex.

Subsections:

- [“Environment” on page 199](#)
- [“Syntax” on page 199](#)
- [“Keywords” on page 199](#)
- [“Usage notes” on page 200](#)
- [“Equivalent WTOR and z/OS commands” on page 200](#)
- [“Output fields” on page 200](#)
- [“Return, reason, and completion codes” on page 201](#)
- [“Return, reason, and completion codes handled by OM” on page 202](#)
- [“Examples” on page 202](#)

## Environment

The **CREATE IMSCON** command is applicable only to IMS Connect. To issue this command, the following conditions must be satisfied:

- IMS Connect must be active and configured to communicate with the Common Service Layer (CSL) Structured Call Interface (SCI).
- A type-2 command environment with Structured Call Interface (SCI) and Operations Manager (OM) must be active.

## Syntax

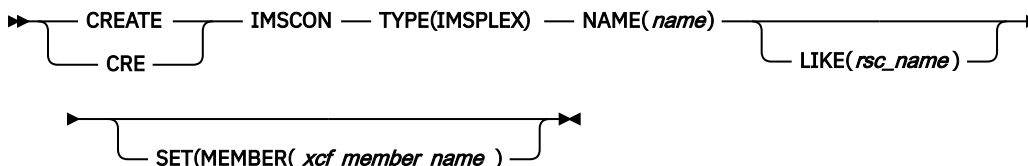

## Keywords

The following keywords are valid for the **CREATE IMSCON TYPE(IMPSPLEX)** command:

### LIKE

Specifies the existing IMS Connect IMSplex resource to use as a model. The new resource is created with all of the same attribute values as the model.

Attributes set explicitly by the **CREATE IMSCON TYPE(IMPSPLEX)** command override the attribute values that are generated from the model. Later changes to the model are not propagated to resources that were created from it.

### NAME

Specifies the 1- to 5-character name of the IMSplex, as specified on the IMPSPLEX(NAME=) statement of the CSLSIxxx member of the IMS PROCLIB data set of the SCI instance that is managing communications between IMS Connect and the IMSplex. The name can consist of alphanumeric characters and must be unique within IMS Connect.

This keyword is equivalent to the TMEMBER parameter of the IMPSPLEX statement in the IMS Connect configuration member.

This parameter is required.

### SET

Specifies the attributes of the IMSplex to be created.

If the LIKE keyword is omitted, the required attributes must be specified. If an optional attribute is not specified, IMS Connect uses its default value.

If the LIKE keyword is specified, the attribute values that are specified with the SET keyword override the values that are generated from the model.

### MEMBER

Specifies a 1- to 8-character alphanumeric name that identifies IMS Connect in the IMSplex.

IMS Connect registers this name with SCI. SCI uses the name to manage communications between IMS Connect and other IMSplex members, such as Operations Manager (OM), ODBM, or MSC. The name must start with an alphabetic character.

This parameter is required if the LIKE keyword parameter is not specified.

## Usage notes

You can issue the **CREATE IMSCON TYPE(IMPSPLEX)** command only through the OM API.

IMS Connect can process IMS Connect type-2 commands only if the IMSplex from which the commands were issued has a status of ACTIVE.

The **CREATE IMSCON TYPE(IMPSPLEX)** command is equivalent to adding an SCI communications path for an IMSplex by specifying the IMPSPLEX statement in the IMS Connect configuration PROCLIB member.

At the completion of the **CREATE IMSCON TYPE(IMPSPLEX)** command, IMS Connect starts the communications path to the IMSplex and sets the IMPSPLEX status to ACTIVE if it is successful and NOTACTIVE if it is not successful.

**Important:** Type-2 commands require IMS Connect to have a communications path to an IMSplex. Your IMS Connect must already have a communications path to the SCI of an IMSplex to be able to issue a **CREATE IMSCON TYPE(IMPSPLEX)** command to add a communications path to a different IMSplex.

Modifications that are made to IMS Connect resources by use of this command are not saved across restarts of IMS Connect.

## Equivalent WTOR and z/OS commands

There are no equivalent WTOR and z/OS commands that perform similar functions as the **CREATE IMSCON TYPE(IMPSPLEX)** command.

## Output fields

The following table shows the **CREATE IMSCON TYPE(IMPSPLEX)** output fields. The columns in the table are:

### Short label

Contains the short label that is generated in the XML output.

### Long label

Contains the column heading for the output field in the formatted output.

### Keyword

Identifies the keyword on the command that caused the field to be generated. N/A is displayed for output fields that are always returned. *error* is displayed for output fields that are returned only in case of an error.

### Meaning

Provides a brief description of the output field.

Table 124. Output fields for the CREATE IMSCON TYPE(IMPSPLEX) command

| Short label | Long label | Keyword | Meaning  |
|-------------|------------|---------|--|
| CC          | CC         | N/A     | Completion code that indicates whether IMS Connect was able to process the command for the specified resource. The completion code is always returned. |
| CCTXT       | CCText     | N/A     | Completion code text that briefly explains the meaning of the nonzero completion code. This field is returned only for an error completion code.       |
| IMSPLX      | IMSplex    | N/A     | The IMSplex name. The IMSplex name is always returned.   |
| MBR         | MbrName    | N/A     | Identifier of the IMS Connect that built the output line. The identifier is always returned.   |

## Return, reason, and completion codes

An IMS Connect return and reason code is returned to OM by the **CREATE IMSCON TYPE(IMSPLEX)** command. The OM return and reason codes that might be returned as a result of the **CREATE IMSCON TYPE(IMSPLEX)** command are standard for all commands that are entered through the OM API.

The following table includes the return and reason codes and a brief explanation of the codes. The return or reason code returned for the command might also indicate an error from a CSL request.

*Table 125. Return and reason codes for the CREATE IMSCON TYPE(IMSPLEX) command*

| Return code | Reason code | Meaning   |
|-------------|-------------|---|
| X'00000000' | X'00000000' | The command completed successfully. The command output contains a line for each resource, which is accompanied by its completion code. For details, see <a href="#">Table 126 on page 201</a> . |
| X'0C000008' | X'00002024' | The LIKE keyword parameter value is invalid. The resource cannot be found.  |
| X'0C000008' | X'00002050' | The required MEMBER parameter is not specified.   |
| X'0C000008' | X'00002098' | The specified MEMBER value is too long. IMSplex member name is maximum of 8 characters.   |
| X'0C00000C' | X'00003000' | The command was successful for some resources but failed for others. The command output contains a line for each resource, which is accompanied by its completion code.                         |
| X'0C00000C' | X'00003004' | The command was not successful for any resource. The command output contains a line for each resource, which is accompanied by its completion code.   |

The following table includes an explanation of the completion codes. Errors unique to the processing of this command are returned as completion codes. A completion code is returned for each action against an individual resource.

*Table 126. Completion codes for the CREATE IMSCON TYPE(IMSPLEX) command*

| Completion code | Completion code text     | Meaning  |
|-----------------|--------------------------|--|
| 0               |                          | The <b>CREATE IMSCON TYPE(IMSPLEX)</b> command completed successfully.   |
| 13              | Resource already exists. | IMSplex already exists.  |
| 1A              | BPEGETM error            | IMS Connect encountered an error while attempting to obtain storage from the BPEGETM service.                          |
| 1C              | FWEB creation failed     | IMS Connect encountered an error while attempting to obtain a block of storage of type FWEB from the BPECBGET service. |
| 1D              | CVBB creation failed     | IMS Connect encountered an error while attempting to obtain a block of storage of type CVBB from the BPECBGET service. |

Table 126. Completion codes for the CREATE IMSCON TYPE(IMPSPLEX) command (continued)

| Completion code | Completion code text             | Meaning   |
|-----------------|----------------------------------|---|
| 3C              | Resource created, start failed   | The <b>CREATE</b> command created a definition of the requested resource in IMS Connect, but the resource failed to start.<br><br>The command output might also contain the following messages, which describe why the resource failed to start: <ul style="list-style-type: none"> <li>• HWSI1705W</li> <li>• HWSI1720W</li> <li>• HWSI1815W</li> <li>• HWSI1816W</li> </ul> |
| 3E              | Wildcard parameter not supported | The <b>CREATE</b> command does not support wildcard parameters. You must explicitly specify the names of the IMSplex you want to create.  |
| 3F              | DCTB creation failed             | IMS Connect encountered an error while attempting to obtain a block of storage of type DCTB from the BPECBGET service.  |
| 40              | Get latch failed                 | IMS Connect failed to obtain a latch.   |
| 41              | NAME value is too long           | The specified NAME value is too long. IMSplex name is maximum of 5 characters.  |
| 53              | CPEX block creation failed       | IMS Connect encountered an error while attempting to obtain a compliance extension (CPEX) block from the BPECBGET service.  |

## Return, reason, and completion codes handled by OM

IMS Connect registers its type-2 command set with OM. When OM detects a command parsing error, OM returns a return code and reason code to the requester, and the command is not routed to IMS Connect.

Clients such as the TSO SPOC send commands to OM by using the CSLOMCMD API. CSLOMCMD return and reason codes are listed in the description of the CSLOMCMD request.

### Examples

The following are examples of the **CREATE IMSCON TYPE(IMPSPLEX)** command:

#### Example 1 for CREATE IMSCON TYPE(IMPSPLEX) command

TSO SPOC input:

```
CREATE IMSCON TYPE(IMPSPLEX) NAME(PLEX2)
SET(MEMBER(ICON1))
```

TSO SPOC output:

```
IMSplex  MbrName      CC
PLEX2    HWS1              0
```

OM API input:

```
CMD(CRE IMSCON TYPE(IMPSPLEX) NAME(PLEX2)
SET(MEMBER(ICON1)))
```

OM API output:

```
<?xml version="1.0"?>
<!DOCTYPE imsout SYSTEM "imsout.dtd">
<imsout>
<ctl>
<omname>OM10M </omname>
<omvsn>1.7.0</omvsn>
<xmlvsn>20 </xmlvsn>
<statime>2014.246 20:20:49.113887</statime>
<stotime>2014.246 20:20:49.165217</stotime>
<staseq>CDB3F4183E71FA55</staseq>
<stoseq>CDB3F4184AFA1FD5</stoseq>
<rqsttkn1>USRT011 10132049</rqsttkn1>
<rc>00000000</rc>
<rsn>00000000</rsn>
</ctl>
<cmd>
<master>HWS1 </master>
<userid>USRT011 </userid>
<verb>CRE </verb>
<kwd>IMSCON </kwd>
<input>CREATE IMSCON TYPE(IMPSPLEX) NAME(PLEX2) SET(MEMBER(ICON1))
</input>
</cmd>
<cmdrsphdr>
<hdr slbl="IMPSPLEX" llbl="IMSpIex" scope="LCL" sort="a" key="1" scroll="no" len="8"
dtype="CHAR" align="left" skipb="no" />
<hdr slbl="MBR" llbl="MbrName" scope="LCL" sort="a" key="2" scroll="no" len="8"
dtype="CHAR" align="left" skipb="no" />
<hdr slbl="CC" llbl="CC" scope="LCL" sort="n" key="0" scroll="yes" len="4"
dtype="INT" align="right" skipb="no" />
<hdr slbl="CCTXT" llbl="CCText" scope="LCL" sort="n" key="0" scroll="yes"
len="32" dtype="CHAR" align="left" skipb="yes" />
</cmdrsphdr>
<cmdrspdata>
<rsp>IMPSPLEX(PLEX2 ) MBR(HWS1 ) CC( 0) </rsp>
</cmdrspdata>
</imsout>
```

**Explanation:** IMSpIex PLEX2 is created with the specified attributes.

### **Example 2 for CREATE IMSCON TYPE(IMPSPLEX) command**

TSO SPOC input:

```
CREATE IMSCON TYPE(IMPSPLEX) NAME(PLEX2) LIKE(PLEX1)
```

TSO SPOC output:

| IMSpIex | MbrName | CC |
|---------|---------|----|
| PLEX2   | HWS1    | 0  |

OM API input:

```
CMD(CRE IMSCON TYPE(IMPSPLEX) NAME(PLEX2) LIKE(PLEX1))
```

OM API output:

```
<?xml version="1.0"?>
<!DOCTYPE imsout SYSTEM "imsout.dtd">
<imsout>
<ctl>
<omname>OM10M </omname>
<omvsn>1.7.0</omvsn>
<xmlvsn>20 </xmlvsn>
<statime>2014.246 20:38:14.619891</statime>
<stotime>2014.246 20:38:14.658339</stotime>
<staseq>CDB3F7FD50EF3C46</staseq>
<stoseq>CDB3F7FD5A523CC4</stoseq>
```

```

<rqsttkn1>USRT011 10133814</rqsttkn1>
<rc>00000000</rc>
<rsn>00000000</rsn>
</ctl>
<cmd>
<master>HWS1 </master>
<userid>USRT011 </userid>
<verb>CRE </verb>
<kwd>IMSCON </kwd>
<input>CREATE IMSCON TYPE(IMSPLEX) NAME(PLEX2) LIKE(PLEX1) </input>
</cmd>
<cmdsphdr>
<hdr slbl="IMSPLEX" llbl="IMSpIex" scope="LCL" sort="a" key="1" scroll="no"
len="8" dtype="CHAR" align="left" skipb="no" />
<hdr slbl="MBR" llbl="MbrName" scope="LCL" sort="a" key="2" scroll="no"
len="8" dtype="CHAR" align="left" skipb="no" />
<hdr slbl="CC" llbl="CC" scope="LCL" sort="n" key="0" scroll="yes" len="4"
dtype="INT" align="right" skipb="no" />
<hdr slbl="CCTXT" llbl="CCText" scope="LCL" sort="n" key="0" scroll="yes"
len="32" dtype="CHAR" align="left" skipb="yes" />
</cmdsphdr>
<cmdsdata>
<rsp>IMSPLEX(PLEX2 ) MBR(HWS1 ) CC( 0) </rsp>
</cmdsdata>
</imsout>

```

**Explanation:** IMSplex PLEX2 is created like IMSplex PLEX1 with the MEMBER attribute of the model PLEX1 attribute.

## CREATE IMSCON TYPE(PORT) command

Use the **CREATE IMSCON TYPE(PORT)** command to add IMS Connect port definitions during runtime processing without having to restart your IMS Connect instance.

The **CREATE IMSCON TYPE(PORT)** command is used to add a listening port.

Specifying PORTTYPE(REG) creates a regular listening port.

Specifying PORTTYPE(DRDA) creates a DRDA listening port.

*Table 127. Type-2 CREATE IMSCON TYPE(PORT) command and HWSCFGxx member configuration equivalents*

| Type-2 command                                 | Configuration for the HWSCFGxx member of the IMS PROCLIB data set |
|--|---|
| <b>CREATE IMSCON TYPE(PORT) PORTTYPE(REG)</b>  | PORT= substatement of the TCPIP statement                         |
| <b>CREATE IMSCON TYPE(PORT) PORTTYPE(DRDA)</b> | DRDAPORT= substatement of the ODACCESS statement                  |

Subsections:

- [“Environment” on page 204](#)
- [“Syntax” on page 205](#)
- [“Keywords” on page 205](#)
- [“Usage notes” on page 207](#)
- [“Equivalent WTOR and z/OS commands” on page 207](#)
- [“Output fields” on page 207](#)
- [“Return, reason, and completion codes” on page 208](#)
- [“Return, reason, and completion codes handled by OM” on page 210](#)
- [“Examples” on page 210](#)

## Environment



The **CREATE IMSCON** command is applicable only to IMS Connect. To issue this command, the following conditions must be satisfied:

- IMS Connect must be active and configured to communicate with the Common Service Layer (CSL) Structured Call Interface (SCI).
- A type-2 command environment with Structured Call Interface (SCI) and Operations Manager (OM) must be active.

## Syntax

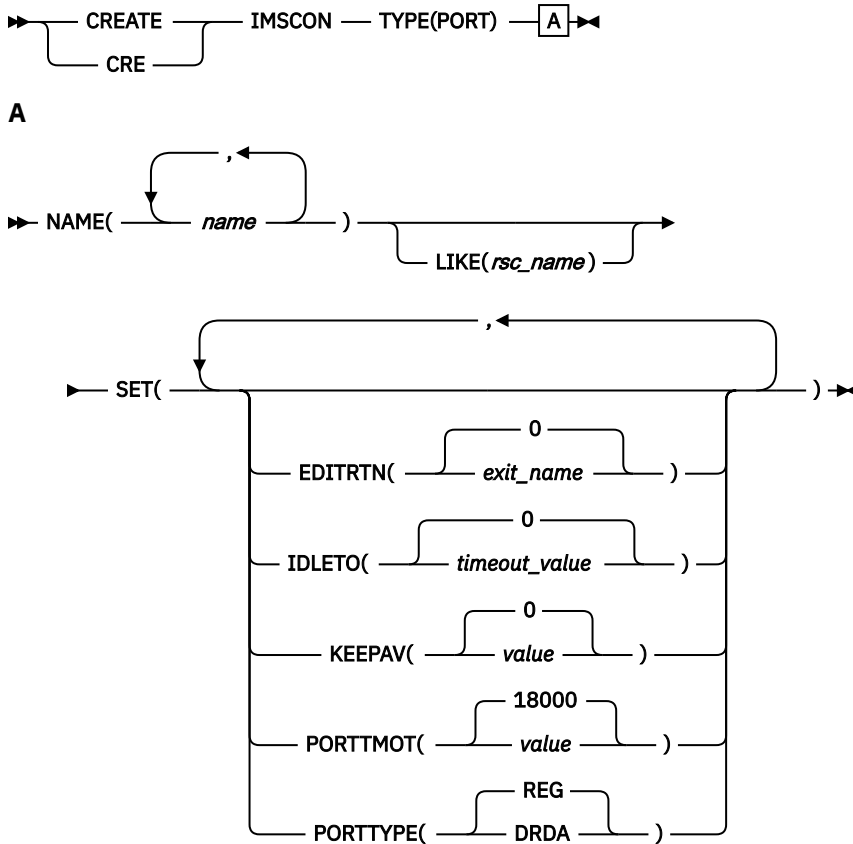

## Keywords

The following keywords are valid for the **CREATE IMSCON TYPE(PORT)** command:

### LIKE

Specifies the existing IMS Connect port resource to use as a model. The new resource is created with all of the same attribute values as the specified model port resource.

Attributes that are set explicitly by the **CREATE IMSCON TYPE(PORT)** command override the attribute values that are generated from the model. Later changes to the model are not propagated to resources that were created from it.

### NAME

Specifies the 1- to 5-character decimal field of the port number. Valid values are decimal numbers 1 - 65535.

Port numbers must be unique for a specific instance of IMS Connect and must not conflict with other ports selected in the TCP/IP domain.

This parameter is required.

**SET**

Specifies the attributes of the port to be created.

If the LIKE keyword is omitted, the required attributes must be specified. If an optional attribute is not specified, IMS Connect uses its default value.

If the LIKE keyword is specified, the attribute values that are specified with the SET keyword override the values that are generated from the model.

**EDITRTN**

Specifies the 1- to 8-character name of the IMS Connect Port Message Edit exit routine.

This parameter is equivalent to the EDIT parameter of the PORT substatement of the TCPIP statement of the HWSCFGxx member of the IMS PROCLIB data set.

The exit routine can modify messages that do not conform to the standard message formats for IMS Connect. The exit routine must be accessible to IMS Connect by JOBLIB, STEPLIB, or LinkList.

This parameter is valid only when the (PORTTYPE(REG)) keyword is specified.

When the LIKE keyword is used to create a port by copying the attributes of an existing port, specifying the numerical character "0" omits the EDITRTN specification from the copied attributes and sets it to blanks, thus disabling the exit routine. If EDITRTN(0) is specified when the LIKE keyword is not specified, the result is the same as omitting the EDITRTN keyword.

This parameter is optional and defaults to blanks.

**IDLETO**

Specifies the timeout interval for open socket connections on this port that are idle and waiting in a RECV state for the next message. When the timeout interval expires, IMS Connect closes the socket connection due to inactivity.

The timeout interval is in hundredths of seconds. Valid values are 0 to 2 147 483 647 (X'7FFFFFFF').

A value of 0 disables this timeout function, which prevents inactive connections from timing out.

If the IDLETO parameter is omitted, the default value is -1, which indicates that the port uses the global-level idle timeout value, if any.

An IDLETO specification in a port definition overrides the global default IDLETO value.

This parameter is valid only when the PORTTYPE(REG) keyword is specified.

**KEEPAV**

Specifies the number of seconds for the z/OS TCP/IP KeepAlive interval for sockets on this port. TCP/IP accepts a range 1 - 2147460 seconds.

Use the TCP/IP KeepAlive function to detect error situations for inactive sockets. Specify the KEEPAV parameter to override the default TCP/IP KeepAlive interval value.

This parameter is optional and defaults to 0. If you specify 0, the KeepAlive interval value is bypassed, and the setting for the TCP/IP stack is used.

**PORTTMOT**

Specifies the numeric value of the DRDA port timeout value.

This value is the amount of time that IMS Connect waits for the next input message from a client application that is connected on a DRDA port before IMS Connect disconnects the client.

The timeout interval is specified as a decimal integer in hundredths of a second. Valid values are 0 - 2,147,483,647 (X'7FFFFFFF').

Specifying a value of 0 disables the timeout function.

This parameter is optional and defaults to 6000 (1 minute).

This parameter is valid only when the PORTTYPE(DRDA) keyword is specified.

**PORTTYPE**

Specifies the type of port.

This keyword is optional and defaults to PORTTYPE(REG).

#### **DRDA**

Indicates that this port is being created for listening to DRDA messages.

Specifying this parameter is equivalent to creating a port by defining the DRDAPORT substatement in the ODACCESS statement of the HWSCFGxx member of the IMS PROCLIB data set.

#### **REG**

Indicates that this port is being created for listening to regular IMS Connect client messages.

Specifying this parameter is equivalent to creating a port by defining the PORT substatement in the TCPIP statement of the HWSCFGxx member of the IMS PROCLIB data set.

## **Usage notes**

You can issue the **CREATE IMSCON TYPE(PORT)** command only through the Operations Manager (OM) API.

The maximum number of ports that can be defined to an instance of IMS Connect is 200.

IMS Connect can process IMS Connect type-2 commands only if the IMSplex from which the commands were issued has a status of ACTIVE.

When a keyword is specified without any value, that keyword is ignored. IMS Connect processes the command as if the keyword were not specified. The following command examples are valid:

- `CREATE IMSCON TYPE(PORT) NAME(1111) SET()`

None of the SET attribute keywords are required, so the command is processed as if it were `CREATE IMSCON TYPE(PORT) NAME(1111)`.

- `CREATE IMSCON TYPE(PORT) NAME(2222) SET(KEEPAV())`

The command is processed as if it were `CREATE IMSCON TYPE(PORT) NAME(2222)`.

- `CREATE IMSCON TYPE(PORT) NAME(3333) LIKE()`

The command is processed as if it were `CREATE IMSCON TYPE(PORT) NAME(3333)`.

At the completion of the **CREATE IMSCON TYPE(PORT)** command, IMS Connect starts the port and sets the port status to ACTIVE if it is successful and NOT ACTIVE if it is not successful.

If TCP/IP is up, at the successful completion of the **CREATE IMSCON TYPE(PORT)** command, IMS Connect issues a HWSS0790I message to the system console. If TCP/IP is down, at the successful completion of the **CREATE IMSCON TYPE(PORT)** command, IMS Connect issues a HWSS0771W message to the system console.

IMS Connect resources that are created by use of this command are not saved across restarts of IMS Connect, unless a corresponding configuration statement is also added to the HWSCFGxx member of the IMS PROCLIB data set before the next restart.

## **Equivalent WTOR and z/OS commands**

Equivalent WTOR and z/OS commands that perform similar functions as the **CREATE IMSCON TYPE(PORT)** command are not available.

## **Output fields**

The following table shows the **CREATE IMSCON TYPE(PORT)** output fields. The following is a list of the columns that are available in the table:

**Short label**

Contains the short label that is generated in the XML output.

**Long label**

Contains the column heading for the output field in the formatted output.

**Keyword**

Identifies the keyword on the command that caused the field to be generated. N/A is displayed for output fields that are always returned. For output fields that are returned only in case of an error, error is displayed.

**Meaning**

Provides a brief description of the output field.

*Table 128. Output fields for the CREATE IMSCON TYPE(PORT) command*

| Short label | Long label | Keyword | Meaning  |
|-------------|------------|---------|--|
| CC          | CC         | N/A     | Completion code that indicates whether IMS Connect was able to process the command for the specified resource. The completion code is always returned. |
| CCTXT       | CCText     | N/A     | Completion code text that briefly explains the meaning of the nonzero completion code. This field is returned only for an error completion code.       |
| MBR         | MbrName    | N/A     | Identifier of the IMS Connect that built the output line. The identifier is always returned.   |
| PORT        | Port       | N/A     | The port number. The port number is always returned.   |

## Return, reason, and completion codes

An IMS Connect return and reason code is returned to OM by the **CREATE IMSCON TYPE(PORT)** command. The OM return and reason codes that might be returned as a result of the **CREATE IMSCON TYPE(PORT)** command are standard for all commands that are entered through the OM API.

The following table includes the return and reason codes and a brief explanation of the codes. The return or reason code returned for the command might also indicate an error from a CSL request.

*Table 129. Return and reason codes for the CREATE IMSCON TYPE(PORT) command*

| Return code | Reason code | Meaning  |
|-------------|-------------|--|
| X'00000000' | X'00000000' | The command completed successfully. The command output contains a line for each resource, which is accompanied by its completion code. See the completion codes table for details. |
| X'0C000008' | X'00002004' | The command contains an invalid primary keyword or no client is registered for the keyword.  |
| X'0C000008' | X'00002010' | Wildcards (* and %) are not supported.   |
| X'0C000008' | X'00002024' | The LIKE keyword parameter value is invalid. The resource cannot be found.   |
| X'0C000008' | X'00002028' | The LIKE keyword parameter value cannot be an SSL port.  |
| X'0C000008' | X'00002058' | IMS Connect could not load the Port Message Edit exit routine.   |
| X'0C000008' | X'00002084' | The EDITRTN keyword is invalid for PORTTYPE(DRDA).   |
| X'0C000008' | X'00002088' | The PORTTMOT keyword is invalid for PORTTYPE(REG).   |

Table 129. Return and reason codes for the CREATE IMSCON TYPE(PORT) command (continued)

| Return code | Reason code | Meaning   |
|-------------|-------------|---|
| X'0C000008' | X'000020BC' | Command specified a port type of DRDA. Command was rejected.  |
| X'0C00000C' | X'00003000' | The command was successful for some resources but failed for others. The command output contains a line for each resource, which is accompanied by its completion code. |
| X'0C00000C' | X'00003004' | The command was not successful for any resource. The command output contains a line for each resource, which is accompanied by its completion code.                     |

The following table includes an explanation of the completion codes. Errors unique to the processing of this command are returned as completion codes. A completion code is returned for each action against an individual resource.

Table 130. Completion codes for the CREATE IMSCON TYPE(PORT) command

| Completion code | Completion code text             | Meaning  |
|-----------------|----------------------------------|--|
| 0               |                                  | The <b>CREATE IMSCON TYPE(PORT)</b> command completed successfully.  |
| 13              | The resource already exists.     | The port already exists.   |
| 39              | Resource created, retrying start | IMS Connect created the port resource but was unable to start the port. It continues to retry starting the port in the background.<br><br>The command output might also contain one of the following messages: <ul style="list-style-type: none"> <li>• HWSP1400W</li> <li>• HWSP1402W</li> <li>• HWSP1405W</li> <li>• HWSP1415I</li> <li>• HWSP1415E</li> <li>• HWSP1420E</li> <li>• HWSP1485E</li> <li>• HWSS0771W</li> <li>• HWSS0777W</li> </ul> |
| 3A              | Resource created, sched failed   | IMS Connect created the port resource, but was unable to start the port scheduler. The command output also contains the following message: HWSS0712W.  |
| 3C              | Resource created, start failed   | The <b>CREATE</b> command has created the definition of the requested resource in IMS Connect, but the resource failed to start.<br><br>The command output might also contain the following message, which describes why the resource failed to start: HWSS0770I.  |

Table 130. Completion codes for the CREATE IMSCON TYPE(PORT) command (continued)

| Completion code | Completion code text    | Meaning   |
|-----------------|-------------------------|---|
| 50              | Max port limit reached  | 200 ports are defined to IMS Connect, which is the maximum number of ports that can be defined for an IMS Connect instance.   |
| 51              | MAXSOC value is too low | The port was not created because the current MAXSOC value cannot support any more ports. The MAXSOC value in the TCPIP statement of the IMS Connect configuration member must be greater than the total number of ports. To add more ports, increase the MAXSOC value to accommodate your client connections and any ports added in the future. |

## Return, reason, and completion codes handled by OM

IMS Connect registers its type-2 command set with OM. When OM detects a command parsing error, OM returns a return code and reason code to the requester, and the command is not routed to IMS Connect.

Clients such as the TSO SPOC send commands to OM by using the CSLOMCMD API. CSLOMCMD return and reason codes are listed in the description of the CSLOMCMD request.

### Examples

The following are examples of the **CREATE IMSCON TYPE(PORT)** command:

#### Example 1 for CREATE IMSCON TYPE(PORT) command

TSO SPOC input:

```
CREATE IMSCON TYPE(PORT) NAME(8888)
SET(EDITRTN(HWSEdit0),KEEPAV(120))
```

TSO SPOC output:

```
Port      MbrName      CC
8888     HWS1         0
```

OM API input:

```
CMD(CRE IMSCON TYPE(PORT) NAME(8888)
SET(EDITRTN(HWSEdit0),KEEPAV(120)))
```

OM API output:

```
<?xml version="1.0"?>
<!DOCTYPE imsout SYSTEM "imsout.dtd">
<imsout>
<ctl>
<omname>OM10M </omname>
<omvsn>1.6.0</omvsn>
<xmlvsn>20 </xmlvsn>
<statime>2012.314 16:51:36.534771</statime>
<stotime>2012.314 16:51:36.535211</stotime>
<staseq>CA723167E3C4711B</staseq>
```

```

<stoseq>CA7231682AD21F14</stoseq>
<rqsttkn1>USRT011 10085423</rqsttkn1>
<rc>00000000</rc>
<rsn>00000000</rsn>
</ctl>
<cmd>
<master>HWS1 </master>
<userid>USRT011 </userid>
<verb>CRE </verb>
<kwd>IMSCON </kwd>
<input>CREATE IMSCON TYPE(PORT) NAME(8888) SET(EDITRTN(HWSEdit0),KEEPAV(120)) </
input>
</cmd>
<cmdsphdr>
<hdr slbl="PORT" llbl="Port" scope="LCL" sort="a" key="1" scroll="no" len="8"
dtype="CHAR" align="left" skipb="no" />
<hdr slbl="MBR" llbl="MbrName" scope="LCL" sort="a" key="2" scroll="no" len="8"
dtype="CHAR" align="left" skipb="no" />
<hdr slbl="CC" llbl="CC" scope="LCL" sort="n" key="0" scroll="yes" len="4"
dtype="INT" align="right" skipb="no" />
<hdr slbl="CCTXT" llbl="CCText" scope="LCL" sort="n" key="0" scroll="yes" len="32"
dtype="CHAR" align="left" skipb="yes" />
</cmdsphdr>
<cmdsdata>
<rsp>PORT(8888 ) MBR(HWS1 ) CC( 0) </rsp>
</cmdsdata>
</imsout>

```

**Explanation:** Regular port 8888 is created with the EDITRTN and KEEPAV attributes specified.

### Example 2 for CREATE IMSCON TYPE(PORT) command

TSO SPOC input:

```

CREATE IMSCON TYPE(PORT) NAME(8888) LIKE(9999)
SET(EDITRTN(HWSEdit0))

```

TSO SPOC output:

| Port | MbrName | CC |
|------|---------|----|
| 8888 | HWS1    | 0  |

OM API input:

```

CMD(CRE IMSCON TYPE(PORT) NAME(8888) LIKE(9999)
SET(EDITRTN(HWSEdit0)))

```

OM API output:

```

<?xml version="1.0"?>
<!DOCTYPE imsout SYSTEM "imsout.dtd">
<imsout>
<ctl>
<omname>OM10M </omname>
<omvsn>1.6.0</omvsn>
<xmlvsn>20 </xmlvsn>
<statime>2012.314 17:20:25.453406</statime>
<stotime>2012.314 17:20:25.535260</stotime>
<staseq>CA7237396535EC18</staseq>
<stoseq>CA7237397931C697</stoseq>
<rqsttkn1>USRT011 10092025</rqsttkn1>
<rc>00000000</rc>
<rsn>00000000</rsn>
</ctl>
<cmd>
<master>HWS1 </master>
<userid>USRT011 </userid>
<verb>CRE </verb>
<kwd>IMSCON </kwd>
<input>CREATE IMSCON TYPE(PORT) NAME(8888) LIKE(9999) SET(EDITRTN(HWSEdit0)) </

```

```

input>
</cmd>
<cmdrsphdr>
<hdr slbl="PORT" llbl="Port" scope="LCL" sort="a" key="1" scroll="no" len="8"
dtype="CHAR" align="left" skipb="no" />
<hdr slbl="MBR" llbl="MbrName" scope="LCL" sort="a" key="2" scroll="no" len="8"
dtype="CHAR" align="left" skipb="no" />
<hdr slbl="CC" llbl="CC" scope="LCL" sort="n" key="0" scroll="yes" len="4"
dtype="INT" align="right" skipb="no" />
<hdr slbl="CCTXT" llbl="CCText" scope="LCL" sort="n" key="0" scroll="yes" len="32"
dtype="CHAR" align="left" skipb="yes" />
</cmdrsphdr>
<cmdrspdata>
<rsp>PORT(8888      ) MBR(HWS1                ) CC(      0) </rsp>
</cmdrspdata>
</imsout>

```

**Explanation:** Regular port 8888 is created with the same attributes as port 9999. However, the EDITRTN attribute is also specified, and its values override the values from the 9999 port model.

### Example 3 for CREATE IMSCON TYPE(PORT) command

TSO SPOC input:

```

CREATE IMSCON TYPE(PORT) NAME(8888,9999)
SET(PORTTYPE(DRDA))

```

TSO SPOC output:

| Port | MbrName | CC | CCText                  |
|------|---------|----|-------------------------|
| 8888 | HWS1    | 0  |                         |
| 9999 | HWS1    | 13 | Resource already exists |

OM API input:

```

CMD(CRE IMSCON TYPE(PORT) NAME(8888,9999)
SET(PORTTYPE(DRDA)))

```

OM API output:

```

<?xml version="1.0"?>
<!DOCTYPE imsout SYSTEM "imsout.dtd">
<imsout>
<ctl>
<omname>OM10M </omname>
<omvsn>1.6.0</omvsn>
<xmlvsn>20 </xmlvsn>
<statime>2012.314 17:30:09.273414</statime>
<stotime>2012.314 17:30:09.277816</stotime>
<staseq>CA7239662B64659E</staseq>
<stoseq>CA7239662C778D9C</stoseq>
<rqsttkn1>USRT011 10093009</rqsttkn1>
<rc>0200000C</rc>
<rsn>00003008</rsn>
<rsnmsg>CSLN054I</rsnmsg>
<rsntxt>None of the clients were successful.</rsntxt>
</ctl>
<cmderr>
<mbr name="HWS1      ">
<typ>IMSCON </typ>
<rc>0C00000C</rc>
<rsn>00003000</rsn>
<rsntxt>At least one request successful </rsntxt>
</mbr>
</cmderr>
<cmd>
<master>HWS1 </master>
<userid>USRT011 </userid>
<verb>CRE </verb>
<kwd>IMSCON </kwd>

```



```

<input>CREATE IMSCON TYPE(PORT) NAME(8888,9999) SET(PORTTYPE(DRDA))
</input>
</cmd>
<cmdsphdr>
<hdr slbl="PORT" llbl="Port" scope="LCL" sort="a" key="1" scroll="no" len="8"
dtype="CHAR" align="left" skipb="no" />
<hdr slbl="MBR" llbl="MbrName" scope="LCL" sort="a" key="2" scroll="no" len="8"
dtype="CHAR" align="left" skipb="no" />
<hdr slbl="CC" llbl="CC" scope="LCL" sort="n" key="0" scroll="yes" len="4"
dtype="INT" align="right" skipb="no" />
<hdr slbl="CCTXT" llbl="CCText" scope="LCL" sort="n" key="0" scroll="yes" len="32"
dtype="CHAR" align="left" skipb="yes" />
</cmdsphdr>
<cmdsdata>
<rsp>PORT(8888      ) MBR(HWS1                ) CC(    0) </rsp>
<rsp>PORT(9999      ) MBR(HWS1                ) CC(   13) CCTXT(Resource already exists) </
rsp>
</cmdsdata>
</imsout>

```

**Explanation:** DRDA port 8888 is created without any attribute overrides. DRDA port 9999 is not created and returns completion code 13, which indicates that port 9999 already exists.

#### **Example 4 for CREATE IMSCON TYPE(PORT) command**

TSO SPOC input:

```
CREATE IMSCON TYPE(PORT) NAME(1234) SET(IDLETO(2000))
```

TSO SPOC output:

| Port | MbrName | CC |
|------|---------|----|
| 1234 | HWS1    | 0  |

OM API input:

```
CMD(CREATE IMSCON TYPE(PORT) NAME(1234) SET(IDLETO(2000)))
```

OM API output:

```

<cmd>
<master>HWS1      </master>
<userid>USRT002 </userid>
<verb>CRE </verb>
<kwd>IMSCON      </kwd>
<input>CREATE IMSCON TYPE(PORT) NAME(1234) SET(IDLETO(2000)) </input>
</cmd>
<cmdsphdr>
<hdr slbl="PORT" llbl="Port" scope="LCL" sort="a" key="1" scroll="no"
len="8" dtype="CHAR" align="left" skipb="no" />
<hdr slbl="MBR" llbl="MbrName" scope="LCL" sort="a" key="2" scroll="no"
len="8" dtype="CHAR" align="left" skipb="no" />
<hdr slbl="CC" llbl="CC" scope="LCL" sort="n" key="0" scroll="yes"
len="4" dtype="INT" align="right" skipb="no" />
<hdr slbl="CCTXT" llbl="CCText" scope="LCL" sort="n" key="0"
scroll="yes" len="32" dtype="CHAR" align="left" skipb="yes" />
</cmdsphdr>
<cmdsdata>
<rsp>PORT(1234      ) MBR(HWS1                ) CC(    0) </rsp>
</cmdsdata>

```

#### **Related reference**

[CSLOMCMDC: command request \(System Programming APIs\)](#)

[IMS Connect Port Message Edit exit routine \(Exit Routines\)](#)

[IMSPLEX statement \(System Definition\)](#)

[ODACCESS statement \(System Definition\)](#)

[TCPIP statement \(System Definition\)](#)

## CREATE LTERM command

Use the **CREATE LTERM** command to create a Multiple Systems Coupling (MSC) remote logical terminal (LTERM) and assign it to an MSC logical link path between two IMS subsystems.

Subsections:

- [“Environment” on page 214](#)
- [“Syntax diagram” on page 214](#)
- [“Keywords” on page 214](#)
- [“Usage notes” on page 215](#)
- [“Output fields” on page 215](#)
- [“Return and reason codes” on page 215](#)
- [“Completion codes” on page 216](#)
- [“Example of the CREATE LTERM command” on page 217](#)

### Environment

The following table lists the environments (DB/BC, DBCTL, and DCCTL) from which the command keywords can be issued.

Table 131. Valid environments for the CREATE LTERM command and keywords

| Command / Keywords | DB/DC | DBCTL | DCCTL |
|--------------------|-------|-------|-------|
| CREATE LTERM       | X     |       | X     |
| NAME               | X     |       | X     |
| SET                | X     |       | X     |
| TYPE               | X     |       | X     |

### Syntax diagram

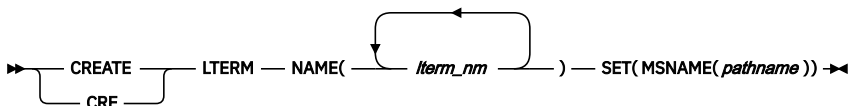

### Keywords

The following keywords are valid for the **CREATE LTERM** command:

#### NAME

Specifies one or more 1- to 8-character names of one or more MSC remote logical terminals.

The name can contain only alphanumeric characters: the letters A through Z, digits 0 through 9, and national characters #, \$, and @.

WTOR, DFSMTCNT, and names that begin with the character sequence INQU are invalid names for an LTERM.

The name of a remote logical terminal cannot be the same as the name of a transaction code, a logical link path, or a local LTERM.

This keyword is required.

## SET()

Specifies the attributes of the LTERM to be created.

### MSNAME

Specifies the 1- to 8-character name of the logical link path to which this remote LTERM is assigned.

## Usage notes

The **CREATE LTERM** command can be issued only through the Operations Manager API. These commands apply to DB/DC and DCCTL systems. The syntax for this command is defined in XML and is available to automation programs that communicate with OM.

MSC remote logical terminals that are added by the CREATE LTERM command are logged to save them across warm and emergency restarts. If you dynamically created MSC remote logical terminal resources with the CREATE LTERM command and want to restore the definitions at the next IMS cold start, you must also perform one of the following actions:

- Export the resources to the IMSRSC repository by using the automatic export function and import the resources at IMS cold start by using the automatic import function.
- Define the resources with stage-1 system definition macros and regenerate the MSC resources into the DFSCLR0x member in the IMS.SDFSRESL data set.

## Output fields

The following table shows the **CREATE LTERM** output fields. The columns in the table are as follows:

### Short label

Contains the short label that is generated in the XML output.

### Keyword

Identifies keyword on the command that caused the field to be generated. N/A appears for output fields that are always returned. The value *error* appears for output fields that are returned only in case of an error.

### Meaning

Provides a brief description of the output field.

*Table 132. Output fields for the CREATE LTERM command*

| Short label | Long label | Keyword | Meaning   |
|-------------|------------|---------|---|
| CC          | CC         | N/A     | Completion code.  |
| CCTXT       | CCText     | N/A     | Completion code text that briefly explains the meaning of the non-zero completion code. |
| MBR         | Mbrname    | N/A     | IMSplex member that built the output line.  |
| LTERM       | Lterm      | N/A     | Logical terminal name.  |

## Return and reason codes

The OM return and reason codes that might be returned as a result of the **CREATE LTERM** command are standard for all commands that are entered through the OM.

The following table includes the return and reason codes and a brief explanation of the codes. The return or reason code returned for the command might also indicate an error from a CSL request.

Table 133. Return and reason codes for the CREATE LTERM command

| Return code | Reason code | Meaning  |
|-------------|-------------|--|
| X'00000000' | X'00000000' | The command completed successfully. The command output contains a line for each resource, which is accompanied by its completion code. See the completion code table for details.                              |
| X'00000008' | X'0000211A' | Invalid MSNAME name.   |
| X'00000008' | X'00002157' | Invalid BACKUP parameter.  |
| X'00000008' | X'00002158' | Invalid BUFSIZE value.   |
| X'0000000C' | X'00003000' | Command was successful for some resources but failed for others. The command output contains a line for each resource, which is accompanied by its completion code. See the completion code table for details. |
| X'0000000C' | X'00003004' | Command was not successful for any of the resources. The command output contains a line for each resource, which is accompanied by its completion code. See the completion code table for details.             |
| X'00000010' | X'0000400C' | Command is not valid on the XRF alternate.   |
| X'00000010' | X'0000402C' | Command is not valid because MSC is not enabled in the IMS system.   |
| X'00000010' | X'0000402D' | Command is not allowed because dynamic definition is not enabled for MSC. MSCRSCS=DYN is not specified in the MSC section of the DFSDFxxx member of the IMS PROCLIB data set.                                  |
| X'00000014' | X'00005004' | A DFSOCMD response buffer could not be obtained.   |
| X'00000014' | X'00005008' | DFSPPOOL storage could not be obtained.  |
| X'00000014' | X'00005010' | Unable to obtain latch.  |

## Completion codes

The following table includes an explanation of the completion codes.

Table 134. Completion codes for the CREATE LTERM command

| Completion code | Completion code text    | Meaning  |
|-----------------|-------------------------|--|
| 0               |                         | The command completed successfully for the remote logical terminal.  |
| 11              | RESOURCE ALREADY EXISTS | A remote logical terminal with the same name already exists.   |
| 17              | ANOTHER CMD IN PROGRESS | Another command is in progress for the LTERM. For example, if an LTERM name is specified twice in a <b>CREATE LTERM</b> command, the second occurrence of the LTERM results in this error. |
| 4E              | LTERM ALREADY EXISTS    | A local LTERM already exists by that name.   |
| 5B              | MSNAME ALREADY EXISTS   | An MSNAME already exists by that name.   |

Table 134. Completion codes for the CREATE LTERM command (continued)

| Completion code | Completion code text             | Meaning   |
|-----------------|----------------------------------|---|
| 5F              | INVALID CHARACTERS IN NAME       | Name is invalid because it contains an invalid character.   |
| 61              | DFSBCB STORAGE ERROR             | Request to get BCB storage for RCNT control block failed.   |
| 7F              | TRANSACTION ALREADY EXISTS       | A transaction already exists by that name.  |
| 8A              | WILDCARD PARAMETER NOT SUPPORTED | The <b>CREATE</b> command does not support wildcard parameters. You must explicitly specify the names of the resources you want to create.  |
| 90              | INTERNAL ERROR                   | An IMS system service failure.  |
| 93              | RESERVED NAME                    | Name is reserved. For example, name starts with DFS (except for DFSSAMxx or DFSIVPxx), or is an IMS reserved name such as BASICEDT or WTOR. |
| 212             | HASH TABLE ADD RCNT FAILED       | Request to add the RCNT to the hash table failed.   |

### Example of the CREATE LTERM command

In the following example, the **CREATE LTERM** command is used to create several MSC remote logical terminals for the MSC logical link path (MSNAME) named LINK31V.

TSO SPOC input:

```
CREATE LTERM NAME(H0G50,H0G51,H0G52) SET(MSNAME(LINK31V))
```

TSO SPOC output:

```
Lterm      MbrName    CC
H0G50      IMS1        0
H0G51      IMS1        0
H0G52      IMS1        0
```

OM API input:

```
CMD(CRE LTERM NAME(H0G50,H0G51,H0G52) SET(MSNAME(LINK31V))
```

OM API output:

```
<imsout>
<ctl>
<omname>OM10M </omname>
<omvsn>1.7.0</omvsn>
<xmlvsn>20 </xmlvsn>
<statime>2014.268 15:37:32.492517</statime>
<stotime>2014.268 15:37:32.493343</stotime>
<staseq>CDCF5DCF24AE5483</staseq>
<stoseq>CDCF5DCF24E1F007</stoseq>
<rqsttkn1>USRT011 10083732</rqsttkn1>
<rc>00000000</rc>
<rsn>00000000</rsn>
</ctl>
<cmd>
<master>IMS1 </master>
<userid>USRT011 </userid>
<verb>CRE </verb>
```

```

<kwd>LTERM          </kwd>
<input>CRE LTERM NAME(H0G50,H0G51,H0G52) SET(MSNAME(LINK31V)) </input>
</cmd>
<cmdsphdr>
<hdr slbl="LTERM" llbl="Lterm" scope="LCL" key="1" len="8" dtype="CHAR"
  align="left" />
<hdr slbl="MBR" llbl="MbrName" scope="LCL" sort="a" key="2" scroll="no"
  len="8" dtype="CHAR" align="left" />
<hdr slbl="CC" llbl="CC" scope="LCL" sort="n" key="0" scroll="yes"
  len="4" dtype="INT" align="right" skipb="no" />
<hdr slbl="CCTXT" llbl="CCText" scope="LCL" sort="n" key="0"
  scroll="yes" len="*" dtype="CHAR" skipb="yes" align="left" />
</cmdsphdr>
<cmdsdata>
<rsp>LTERM(H0G50   ) MBR(IMS1   ) CC(   0) </rsp>
<rsp>LTERM(H0G51   ) MBR(IMS1   ) CC(   0) </rsp>
<rsp>LTERM(H0G52   ) MBR(IMS1   ) CC(   0) </rsp>
</cmdsdata>
</imsout>

```

## CREATE MSLINK command

Use the **CREATE MSLINK** command to dynamically create a Multiple Systems Coupling (MSC) logical link between two MSC-enabled IMS systems.

You can assign a logical link to a physical link when you define it or later by using either the IMS type-2 **UPDATE MSLINK** command or the type-1 **/MSASSIGN LINK** command.

You can define a maximum of 1018 logical links in an IMS system.

Subsections:

- [“Environment” on page 218](#)
- [“Syntax diagrams” on page 218](#)
- [“Keywords” on page 220](#)
- [“Usage notes” on page 222](#)
- [“Output fields” on page 223](#)
- [“Return and reason codes” on page 223](#)
- [“Completion codes” on page 224](#)
- [“Example of the CREATE MSLINK command” on page 225](#)

### Environment

The following table lists the environments (DB/BC, DBCTL, and DCCTL) from which the command keywords can be issued.

*Table 135. Valid environments for the CREATE MSLINK command and keywords*

| Command / Keywords          | DB/DC | DBCTL | DCCTL |
|-----------------------------|-------|-------|-------|
| CREATE MSLINK NAME () SET() | X     |       | X     |

### Syntax diagrams

The syntax diagram for the CREATE MSLINK command is shown as several different syntax diagrams based on the type of physical link the logical link will be assigned to.

### CTC: Syntax diagram for logical links that are assigned to CTC physical links

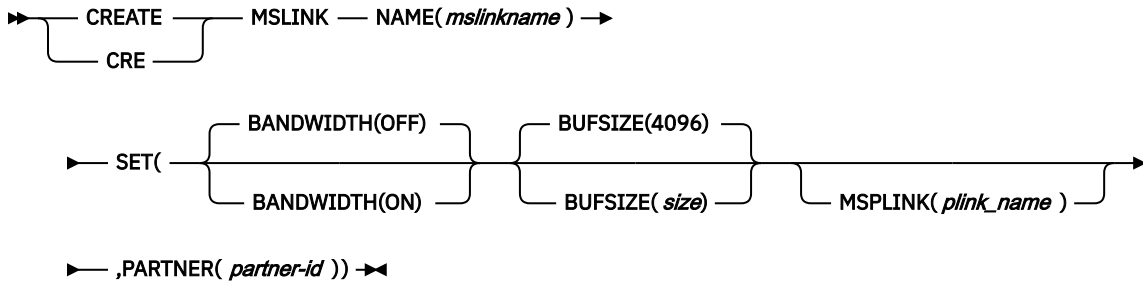

### MTM: Syntax diagram for logical links that are assigned to MTM physical links

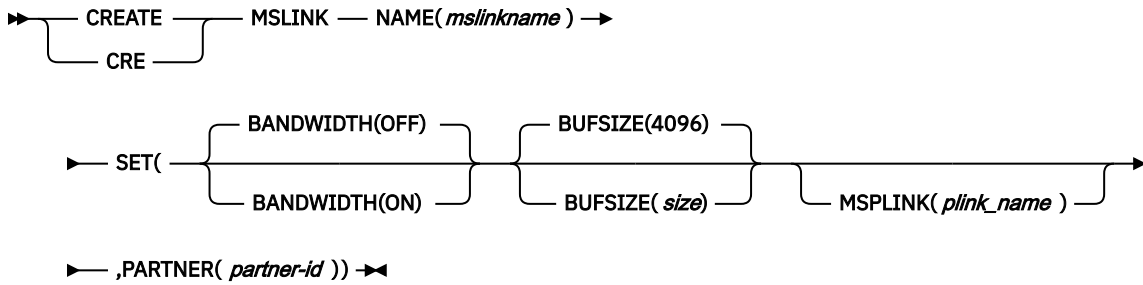

### TCP/IP: Syntax diagram for logical links that are assigned to TCP/IP physical links

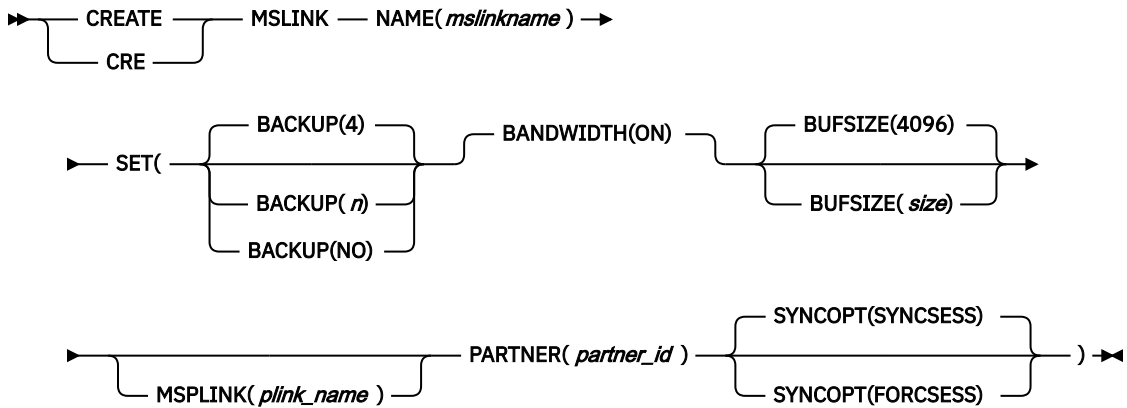

## VTAM: Syntax diagram for logical links that are assigned to VTAM physical links

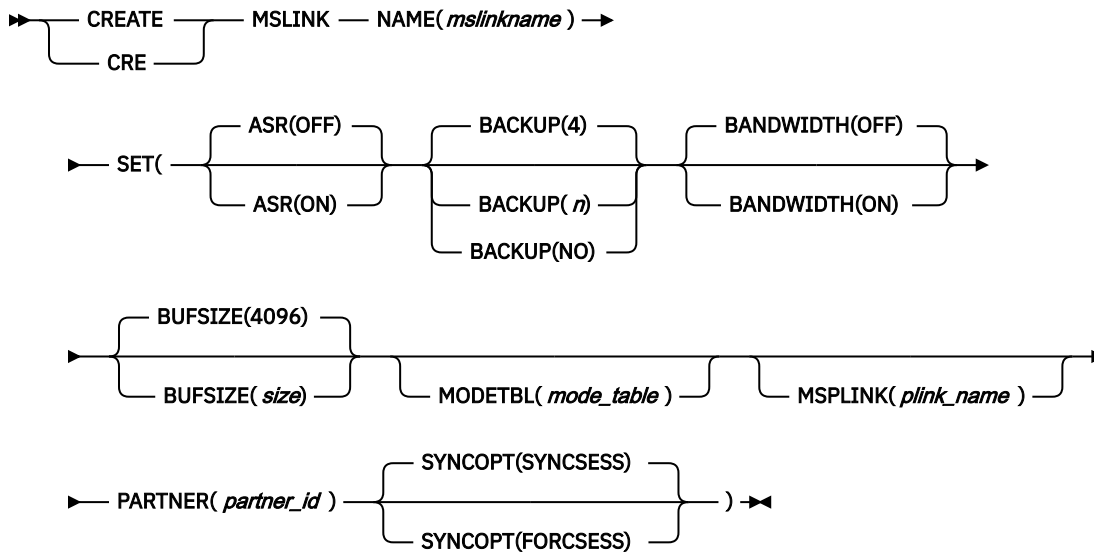

### Keywords

The following keywords are valid for the **CREATE MSLINK** command:

#### ASR(OFF | ON)

Specifies the Automatic Session Restart (ASR) when the Session Outage Notification facility is used. ASR(OFF) is the default.

ASR applies only to logical links that are assigned to VTAM physical links when both sides of the link are using the ASR option.

An ASR specification in the definition of a logical link overrides ASR specifications in the definitions of both terminals and physical links.

To display the current ASR setting you can use either of the following commands:

- The type-1 command **/DISPLAY LINK**
- The type-2 command **QUERY MSLINK NAME(linkname) SHOW(STATUS)**

To change the current ASR option you can use either of the following commands:

- The type-1 command **/CHANGE LINK**
- The type-2 command **UPDATE MSLINK NAME(linkname) SET(ASR(OFF | ON))**

#### BACKUP

For XRF-capable IMS systems, controls the automatic restart of TCP/IP and VTAM links after an XRF takeover.

The specification of BACKUP in the definition of a logical link overrides any switching options that are specified in the definition of the associated physical link. Use only if HSB=YES is specified on the IMSCTRL macro.

The value of *n* is a numeric integer from 1 to 7, inclusive, that sets the priority for reestablishing the session. When either the BACKUP keyword is omitted or no value is specified for BACKUP in the definition of either the physical or logical link, the default is 4. NO suppresses the session recovery of the physical link at takeover.

BACKUP is an MSC physical link attribute that you can set by using the **CREATE MSPLINK**, **CREATE MSLINK**, or **UPDATE MSPLINK** command. You can display the physical link BACKUP value by using the **QUERY MSPLINK** and **QUERY MSLINK** commands.



**Important:** Even though BACKUP is a physical link attribute, the **CREATE MSLINK** NAME(*linkname*) SET(MSPLINK(*msplinkname*)) command can also change the BACKUP value of the specified physical link. You can use the **QUERY MSPLINK** command to display the updated BACKUP value. You can also use the **QUERY MSLINK** command and specify the MSC logical links, including the newly created logical link, that are assigned to the physical link to display the updated BACKUP value.

Although BACKUP prioritizes the order in which IMS restarts TCP/IP and VTAM links, the active requests might be completed in any order because of variables such as internal VTAM conflicts and pacing, TCP/IP network traffic, and so on.

### **BANDWIDTH(OFF | ON)**

Specifies whether the logical link uses bandwidth mode.

#### **OFF**

Specifies that the logical link does not use bandwidth mode. However, if the physical link type specified by MSPLINK parameter is TCPIP, the bandwidth mode is set on. OFF is the default.

#### **ON**

Specifies that the logical link uses bandwidth mode.

### **BUFSIZE**

Specifies the input and output buffer sizes for the newly created logical link.

The valid range of buffer sizes for all link types is 1024 - 65536 bytes.

The same buffer size must be specified by the IMS systems at each end of a physical link.

If BUFSIZE is specified, the created logical link sets its buffer size to the value that is passed by BUFSIZE parameter.

If BUFSIZE is not specified but MSPLINK is specified, the buffer size of the created logical link inherits the buffer size from its physical link.

If both BUFSIZE and MSPLINK parameters are not specified, the created logical link takes the default value 4096 for its buffer size.

### **MODETBL**

Specifies the name of the VTAM logon mode table entry (logon mode name) containing the SNA bind parameters to be used when a session is established for this terminal.

This function allows a specification for referencing an entry other than the default entry in the user's VTAM logon mode table.

With this function, if MODETBL is not specified, no functional or operational change affects the user.

If MODETBL is specified, the specified entry name is used.

You can display the current MODETBL name by using either the **/DISPLAY LINK** command or the **QUERY MSLINK** command. You can override the MODETBL name by using any of the following commands:

- The **VARY ACT, LOGON=** command by the network terminal operator
- The **/RST LINK** or the **/CHANGE LINK** command by the master terminal operator
- The type-2 command **UPDATE MSLINK** NAME(*linkname*) SET(MODETBL(*modetablename*)) through the OM API

If the VTAM-node=name being defined is in another domain (that is, a cross-domain resource), the MODETBL parameter need not be specified.

**Related reading:** See *z/OS Communications Server: SNA Programming* for additional information.

### **MSPLINK**

Assigns the logical link to the specified physical link.

If MSPLINK is specified, the physical link must exist in the system. When the physical link is either a TCP/IP physical link or a VTAM physical link, it must be stopped. When the physical link is either a CTC physical link or a MTM physical link, it must not be assigned to a logical link.

If you do not specify this keyword, the logical link is not assigned to a physical link.

You can assign this logical link to a physical link later by using either the **/MSASSIGN LINK** command or the type-2 command **UPDATE MSLINK** NAME(*linkname*) SET(MSPLINK(*msplinkname*)).

You must assign the logical link to a physical link before communication can be established between the two systems.

#### **PARTNER**

A 2-character alphanumeric identification that associates this logical link with its associated logical definition in the partner IMS system. The partner ID ensures that the two related logical link definitions in the partner IMS systems are always logically and physically connected. Both systems must have logical links that are defined with the same partner ID. If the logical link is assigned to a different physical link, the two systems can still communicate through the logical link, which remains as defined.

You can modify the partner ID by using the type-2 command **UPDATE MSLINK** NAME(*linkname*) SET(PARTNER(*partner-id*)).

#### **SYNCOPT(SYNCSSESS | FORCSSESS)**

For logical links that are assigned to TCP/IP or VTAM physical links only, specifies the session resynchronization options for the logical link.

##### **SYNCSSESS**

Indicates that session initiation is to be completed only if session resynchronization is successful. Successful session resynchronization occurs when the message sequence numbers of the two logical units in session agree, or when the sequence number of the sender is not less than the sequence number of the receiver. SYNCSSESS is the default.

##### **FORCSSESS**

Forces the session initiation to be completed regardless of whether session resynchronization is successful.

The SYNCOPT setting can be overridden by either the type-1 command **/CHANGE LINK** *nn* FORCSSESS | SYNCSSESS | COLDSSESS or the type-2 command **UPDATE MSLINK** NAME(*linkname*) SET(SYNCOPT(FORCSSESS | SYNCSSESS | COLDSSESS)).

## **Usage notes**

The **CREATE MSLINK** command can be issued only through the Operations Manager API. These commands apply to DB/DC and DCCTL systems. The syntax for this command is defined in XML and is available to automation programs that communicate with OM.

MSC logical link resources that are added by the **CREATE MSLINK** command are logged to save them across warm and emergency restarts. If you dynamically created MSC logical link resources with the **CREATE MSLINK** command and want to restore the definitions at the next IMS cold start, you must also perform one of the following actions:

- Export the resources to the IMSRSC repository by using the automatic export function and import the resources at IMS cold start by using the automatic import function.
- Define the resources with stage-1 system definition macros and regenerate the MSC resources into the DFSCLL3x member in the IMS.SDFSRESL data set.

The **CREATE MSLINK** NAME(*mslinkname*) command specified with SET(MSPLINK(*msplinkname*)) is rejected if at least one logical link attribute specified in the command (ASR, BACKUP, MODETBL, or SYNCOPT) conflicts with the physical link type. However, after the logical link is created, it can be reassigned to any type of physical link with an **UPDATE MSLINK** command or an **/MSASSIGN** command. If a logical link defined with attributes applicable to specific physical link types is reassigned to a different physical link type that does not support those attributes, they are ignored when the link is started. The attributes are still defined for the logical link and can be displayed.

## Output fields

The following table shows the **CREATE MSLINK** output fields. The columns in the table are as follows:

### Short label

Contains the short label that is generated in the XML output.

### Keyword

Identifies keyword on the command that caused the field to be generated. N/A appears for output fields that are always returned. The value *error* appears for output fields that are returned only in case of an error.

### Meaning

Provides a brief description of the output field.

*Table 136. Output fields for the CREATE MSLINK command*

| Short label | Long label | Keyword | Meaning  |
|-------------|------------|---------|--|
| CC          | CC         | N/A     | Completion code  |
| CCTXT       | CCText     | N/A     | Completion code text that briefly explains the meaning of the non-zero completion code |
| MBR         | MbrName    | N/A     | IMSPlex member that built the output line  |
| MSCL        | MSLink     | N/A     | Logical link name  |

## Return and reason codes

The OM return and reason codes that might be returned as a result of the **CREATE MSLINK** command are standard for all commands that are entered through the OM.

The following table includes the return and reason codes and a brief explanation of the codes. The return or reason code returned for the command might also indicate an error from a CSL request.

*Table 137. Return and reason codes for the CREATE MSLINK command*

| Return code | Reason code | Meaning   |
|-------------|-------------|---|
| X'00000000' | X'00000000' | The command completed successfully. The command output contains a line for each resource, which is accompanied by its completion code. See the completion code table for details. |
| X'00000008' | X'00002157' | Invalid BACKUP parameter  |
| X'00000008' | X'00002158' | Invalid BUFSIZE value.  |
| X'00000008' | X'0000215F' | Invalid MODETBL name.   |
| X'00000008' | X'0000216E' | TCP/IP requires BANDWIDTH(ON).  |
| X'00000008' | X'0000216F' | PARTNER ID is not specified, but is required.   |
| X'00000008' | X'00002170' | The MSPLINK has an active MSLINK.   |
| X'00000008' | X'00002171' | The specified MSPLINK is a TCP/IP or VTAM link that is not stopped.   |
| X'00000008' | X'00002172' | MSPLINK is already assigned to a logical link.  |
| X'00000008' | X'00002173' | PARTNER ID already exists.  |
| X'00000008' | X'00002174' | PARTNER ID is invalid.  |
| X'00000008' | X'00002175' | SYNCOPT parameter conflicts with the MSPLINK type.  |

Table 137. Return and reason codes for the CREATE MSLINK command (continued)

| Return code | Reason code | Meaning  |
|-------------|-------------|--|
| X'0000000C' | X'00003000' | Command was successful for some resources but failed for others. The command output contains a line for each resource, which is accompanied by its completion code. See the completion code table for details. |
| X'0000000C' | X'00003004' | Command was not successful for any of the resources. The command output contains a line for each resource, which is accompanied by its completion code. See the completion code table for details.             |
| X'00000010' | X'0000400C' | Command is not valid on the XRF alternate.   |
| X'00000010' | X'0000402C' | Command is not valid because MSC is not enabled in the IMS system.   |
| X'00000010' | X'0000402D' | Command is not allowed because dynamic definition is not enabled for MSC. MSCRSCS=DYN is not specified in the MSC section of the DFSDFxxx member of the IMS PROCLIB data set.                                  |
| X'00000010' | X'0000402E' | Command is not valid because the system is not an XRF active system.   |
| X'00000014' | X'00005004' | A DFSOCMD response buffer could not be obtained.   |
| X'00000014' | X'00005008' | DFSPPOOL storage could not be obtained.  |
| X'00000014' | X'00005010' | Unable to obtain latch.  |

## Completion codes

The following table includes an explanation of the completion codes.

Table 138. Completion codes for the CREATE MSLINK command

| Completion code | Completion code text       | Meaning  |
|-----------------|----------------------------|--|
| 0               |                            | The command completed successfully for the logical link.   |
| 11              | RESOURCE ALREADY EXISTS    | A logical link with the same name already exists.  |
| 17              | ANOTHER CMD IN PROGRESS    | Another command (such as <b>DELETE MSLINK</b> or <b>UPDATE MSLINK</b> ) is in progress for the logical link. |
| 5F              | INVALID CHARACTERS IN NAME | Name is invalid because it contains an invalid character.  |
| 61              | DFSBCB STORAGE ERROR       | Request to get BCB storage for LLB control block failed.   |
| 62              | HIOP STORAGE ERROR         | Request to get HIOP storage failed.  |

Table 138. Completion codes for the CREATE MSLINK command (continued)

| Completion code | Completion code text             | Meaning  |
|-----------------|----------------------------------|--|
| 8A              | WILDCARD PARAMETER NOT SUPPORTED | The <b>CREATE</b> command does not support wildcard parameters. You must explicitly specify the names of the resources you want to create.   |
| 8D              | RESOURCE IS NOT STOPPED          | The MSC logical link resource is not stopped.  |
| 90              | INTERNAL ERROR                   | An IMS system service failure.   |
| 93              | RESERVED NAME                    | Name is reserved. For example, name starts with DFS (except for DFSSAMxx or DFSIVPxx), or is an IMS reserved name, such as BASICEDT or WTOR. |
| 206             | CREATED LINK ENQUEUE FAILED      | The enqueue of the logical link LLB control block onto one of the LLB chains failed.   |
| 208             | MAX LINK NUMBER REACHED          | The maximum number of MSC logical links has been reached.  |
| 20E             | NAME CANNOT BEGIN WITH A NUMBER  | The MSLINK name must begin with an alphabetic character. It cannot begin with a number.  |
| 215             | ENQUEUE INTERNAL LNB FAILED      | Hash internal LNB failed.  |
| 216             | CREATE MSLINK ITASK FAILED       | Create MSLINK itask failed.  |
| 217             | BUILD INTERNAL MSNAME FAILED     | The build of the internal MSNAME - MSNI $nnn$ for the newly created logical link failed.   |

### Example of the CREATE MSLINK command

In the following example, one MSC VTAM logical link is dynamically created. Only one logical link can be created at a time because the partner ID must be unique.

TSO SPOC input:

```
CREATE MSLINK NAME(LNKV0001) SET(MSPLINK(PLNK12V),PARTNER(ZA))
```

TSO SPOC output:

```
MSLink  MbrName  CC
LNKV0001 IMS1    0
```

OM API input:

```
CMD(CRE MSLINK NAME(LNKV0001) SET(MSPLINK(PLNK12V),PARTNER(ZA)))
```

OM API output:

```
<imsout>
<ctl>
<omname>OM10M </omname>
<omvsn>1.7.0</omvsn>
<xm1vsn>20 </xm1vsn>
<statime>2015.058 22:58:56.342531</statime>
```

```

<stotime>2015.058 22:58:56.343694</stotime>
<staseq>CE92A18E8E6039E3</staseq>
<stoseq>CE92A18E8EA8EE8A</stoseq>
<rqsttkn1>USRT011 10145856</rqsttkn1>
<rc>00000000</rc>
<rsn>00000000</rsn>
</ctl>
<cmd>
<master>IMS1 </master>
<userid>USRT011 </userid>
<verb>CRE </verb>
<kwd>MSLINK </kwd>
<input>CREATE MSLINK NAME(LNKV0001) SET(MSPLINK(PLNK12V),PARTNER(ZA))
</input>
</cmd>
<cmdsphdr>
<hdr slbl="MSCL" llbl="MSLink" scope="LCL" sort="a" key="1" scroll="
no" len="8" dtype="CHAR" align="left" />
<hdr slbl="MBR" llbl="MbrName" scope="LCL" sort="a" key="2"
scroll="no"len="8" dtype="CHAR" align="left" />
<hdr slbl="CC" llbl="CC" scope="LCL" sort="n" key="0"
scroll="yes"len="4" dtype="INT" align="right" skipb="no" />
<hdr slbl="CCTXT" llbl="CCText" scope="LCL" sort="n" key="0"
scroll="yes" len="*" dtype="CHAR" skipb="yes" align="left" />
</cmdsphdr>
<cmdsdata>
MSCL(LNKV0001) MBR(IMS1 ) CC( 0)
</cmdsdata>
</imsout>

```

## CREATE MSNAME command

Use the **CREATE MSNAME** command to define a unique Multiple Systems Coupling (MSC) logical link path between a local IMS system and a remote IMS system.

In a logical link path, the local IMS system is identified by local system identifier (SIDL) and the remote IMS system is identified by the remote system identifier (SIDR).

In an IMS system, each logical link path is defined by a unique SIDL and SIDR pair and a one-to-one relationship exists between a logical link path and a SIDR. When defining a remote application program to a local IMS system, the application and transaction definitions must refer to a remote SYSID of a logical link path that is defined in the same IMS system. You can define an application program as remote either dynamically with the command **CREATE TRAN SET**(PGM(*pgmname*),SIDL(*sidl*),SIDR(*sidr*)) or statically with the SYSID parameter on either the APPLCTN or TRANSACT system definition macro.

Subsections:

- [“Environment” on page 226](#)
- [“Syntax diagram” on page 227](#)
- [“Keywords” on page 227](#)
- [“Usage notes” on page 227](#)
- [“Output fields” on page 228](#)
- [“Return and reason codes” on page 228](#)
- [“Completion codes” on page 229](#)
- [“Example of creating a logical link path” on page 230](#)

### Environment

The following table lists the environments (DB/BC, DBCTL, and DCCTL) from which the command keywords can be issued.

Table 139. Valid environments for the CREATE MSNAME command and keywords

| Command / Keywords | DB/DC | DBCTL | DCCTL |
|--------------------|-------|-------|-------|
| CREATE MSNAME      | X     |       | X     |

## Syntax diagram

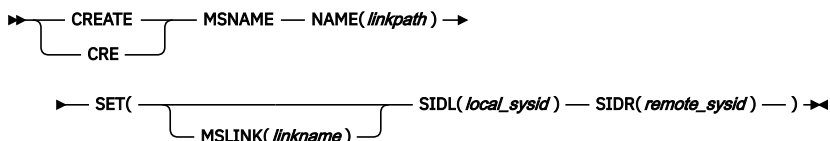

## Keywords

The following keywords are valid for the **CREATE MSNAME** command:

### NAME()

The 1- to 8-character name of the MSC logical link path to be created.

### SET()

Specifies the attributes of the logical link path.

### MSLINK()

The 1- to 8-character name of the MSC logical link that you want to assign this logical link path to. The logical link name specified must already exist.

Before the logical link path can be assigned to a logical link, the specified logical link must be stopped. If the logical link is not stopped, the command terminates without creating the logical link path.

### SIDL()

A numeric value from 1 - 2036 that defines the local IMS system identifier of the logical link path. The local system ID is used for routing messages back to this system.

The value specified on the SIDL keyword cannot be the same as the remote system ID (SIDR) value of any logical link path that is defined to the local IMS system.

### SIDR()

A numeric value from 1 - 2036 that defines the remote IMS system identifier of the logical link path.

The value specified on the SIDR keyword must be unique among the SIDL and SIDR values of all of the logical link paths that are defined to the local IMS system.

Also, the SIDR value cannot be the same as the local system ID (SIDL) value specified on any APPLCTN macro or for any transaction that is defined to the local IMS system.

## Usage notes

The **CREATE MSNAME** command can be issued only through the Operations Manager API. These commands apply to DB/DC and DCCTL systems. The syntax for this command is defined in XML and is available to automation programs that communicate with OM.

To determine if a proposed NAME, SIDR, or SIDL value is already in use by another logical link path that is defined to the local IMS system, you can issue the **QUERY MSNAME NAME(\*) SHOW(SYSID)** type-2 command.

To determine if a proposed SIDR value is already in use as a SIDL by a transaction defined to the local IMS system, you can issue the **QUERY TRAN NAME(\*) SHOW(MSNAME)** type-2 command.

After a logical link path is defined, you can change its remote or local system ID by using the type-2 command **UPDATE MSNAME** NAME(*msname*) SET(SIDR(*remote\_sysid*), SIDL(*local\_SID*)).

In a shared-queues environment, the CREATE MSNAME command creates the MSC MSNAME (logical link path) locally in the IMS that has a physical link outside the IMSplex, and causes a dynamic MSNAME to be created in all the other IMSs in the shared-queues group.

MSC logical link path resources that are added by the CREATE MSNAME command are logged to save them across warm and emergency restarts. If you dynamically created MSC logical link path resources with the CREATE MSNAME command and want to restore the definitions at the next IMS cold start, you must also perform one of the following actions:

- Export the resources to the IMSRSC repository by using the automatic export function and import the resources at IMS cold start by using the automatic import function.
- Define the resources with stage-1 system definition macros and regenerate the MSC resources into the DFSCLC0x member in the IMS.SDFSRESL data set.

## Output fields

The following table shows the **CREATE MSNAME** output fields. The columns in the table are as follows:

### Short label

Contains the short label that is generated in the XML output.

### Keyword

Identifies keyword on the command that caused the field to be generated. N/A appears for output fields that are always returned. The value *error* appears for output fields that are returned only in case of an error.

### Meaning

Provides a brief description of the output field.

*Table 140. Output fields for the CREATE MSNAME command*

| Short label | Long label | Keyword | Meaning   |
|-------------|------------|---------|---|
| CC          | CC         | N/A     | Completion code.  |
| CCTXT       | CCText     | N/A     | Completion code text that briefly explains the meaning of the non-zero completion code. |
| MBR         | MbrName    | N/A     | IMSplex member that built the output line.  |
| MSN         | MSName     | N/A     | The name of the logical link path.  |

## Return and reason codes

The OM return and reason codes that might be returned as a result of the **CREATE MSNAME** command are standard for all commands that are entered through the OM.

The following table includes the return and reason codes and a brief explanation of the codes. The return or reason code returned for the command might also indicate an error from a CSL request.

*Table 141. Return and reason codes for the CREATE MSNAME command*

| Return code | Reason code | Meaning   |
|-------------|-------------|---|
| X'00000000' | X'00000000' | The command completed successfully. The command output contains a line for each resource, which is accompanied by its completion code. See the completion code table for details. |



Table 141. Return and reason codes for the CREATE MSNAME command (continued)

| Return code | Reason code | Meaning  |
|-------------|-------------|--|
| X'00000008' | X'00002127' | SIDL/SIDR must be specified as a pair. Either SIDL was specified alone, or SIDR was specified alone.   |
| X'00000008' | X'00002136' | The name specified in MSLINK() is not a valid logical link name.   |
| X'0000000C' | X'00003000' | Command was successful for some resources but failed for others. The command output contains a line for each resource, which is accompanied by its completion code. See the completion code table for details. |
| X'0000000C' | X'00003004' | Command was not successful for any of the resources. The command output contains a line for each resource, which is accompanied by its completion code. See the completion code table for details.             |
| X'00000010' | X'00004000' | Command is not valid during IMS restart.   |
| X'00000010' | X'0000400C' | Command is not valid on the XRF alternate.   |
| X'00000010' | X'0000402C' | Command is not valid because MSC is not enabled in the IMS system.   |
| X'00000010' | X'0000402D' | Command is not allowed because dynamic definition is not enabled for MSC. MSCRSCS=DYN is not specified in the MSC section of the DFSDFxxx member of the IMS PROCLIB data set.                                  |
| X'00000014' | X'00005004' | Command processing terminated because a DFSOCMD response buffer could not be obtained.   |
| X'00000014' | X'00005008' | DFSPPOOL storage could not be obtained.  |
| X'00000014' | X'0000500C' | AWE get error.   |
| X'00000014' | X'00005010' | Unable to obtain latch.  |
| X'00000014' | X'00005058' | Synchronizing with DFSMNZ00 error.   |
| X'00000014' | X'00005FFF' | IMS internal error.  |

## Completion codes

The following table includes an explanation of the completion codes.

Table 142. Completion codes for the CREATE MSNAME command

| Completion code | Completion code text    | Meaning   |
|-----------------|-------------------------|---|
| 0               |                         | The command completed successfully for the physical link.                                       |
| 11              | RESOURCE ALREADY EXISTS | A logical link path with the same name already exists.  |
| 45              | INVALID SIDR VALUE      | The value specified in SIDR() is invalid. The value must be currently undefined in this system. |

Table 142. Completion codes for the CREATE MSNAME command (continued)

| Completion code | Completion code text             | Meaning   |
|-----------------|----------------------------------|---|
| 4E              | LTERM ALREADY EXISTS             | An LTERM already exists by that name.   |
| 5F              | INVALID CHARACTERS IN NAME       | Name is invalid because it contains an invalid character.   |
| 7F              | TRANSACTION ALREADY EXISTS       | Transaction already exists by that name.  |
| 83              | INVALID SIDL VALUE               | The value specified in SIDL() is invalid. The value must be currently undefined or local in this system.                                    |
| 8A              | WILDCARD PARAMETER NOT SUPPORTED | The <b>CREATE</b> command does not support wildcard parameters. You must explicitly specify the names of the resources you want to create.  |
| 90              | INTERNAL ERROR                   | An IMS system service failure.  |
| 93              | RESERVED NAME                    | Name is reserved. For example, name starts with DFS (except for DFSSAMxx or DFSIVPxx), or is an IMS reserved name such as BASICEDT or WTOR. |
| 102             | MSLINK NOT STOPPED               | The create cannot complete because the link specified in MSLINK() is not stopped.   |
| 10D             | INVALID SIDL, LESS THAN LOW SIDL | The value specified in SIDL() is invalid. The value cannot be lower than the current lowest local SID in this system.                       |
| 20C             | MSNAME ITASK CREATE FAILED       | IMS encountered an internal error and failed to create an LNB for MSNAME.   |

### Example of creating a logical link path

In the following example, the CREATE MSNAME command creates a logical link path named MSNV001. The remote system identifier is 55 and the local system identifier is 755.

TSO SPOC input:

```
CRE MSNAME NAME(MSNV001) SET(SIDR(55),SIDL(755))
```

TSO SPOC output:

```
MSName  MbrName CC
MSNV001 IMS1    0
```

OM API input:

```
CMD(CRE MSNAME NAME(MSNV001) SET(SIDR(55),SIDL(755))
```

OM API output:

```
<imsout>
<ctl>
<omname>OM10M </omname>
<omvsn>1.7.0</omvsn>
<xmlvsn>20 </xmlvsn>
<statime>2015.061 23:55:44.495618</statime>
```

```

<stotime>2015.061 23:55:44.496502</stotime>
<staseq>CE9673D93500258C</staseq>
<stoseq>CE9673D935376B16</stoseq>
<rqsttkn1>USRT011 10155544</rqsttkn1>
<rc>00000000</rc>
<rsn>00000000</rsn>
</ctl>
<cmd>
<master>IMS1 </master>
<userid>USRT011 </userid>
<verb>CREATE </verb>
<kwd>MSNAME </kwd>
<input>CREATE MSNAME NAME(MSNV001)
SET(MSLINK(LNK12V02),SIDR(55),SIDL(705)) </input>
</cmd>
<cmdsphdr>
<hdr slbl="MSN" llbl="MSName" scope="LCL" sort="a" key="1" scroll="no"
len="8" dtype="CHAR" align="left" skipb="no" />
<hdr slbl="MBR" llbl="MbrName" scope="LCL" sort="a" key="3" scroll="no"
len="8" dtype="CHAR" align="left" skipb="no" />
<hdr slbl="CC" llbl="CC" scope="LCL" sort="n" key="0" scroll="yes"
len="4" dtype="INT" align="right" skipb="no" />
</cmdsphdr>
<cmdsdata>
<rsp>MSN(MSNV001 ) MBR(IMS1) CC( 0) </rsp>
</cmdsdata>
</
imsout>

```

## CREATE MSPLINK command

Use the **CREATE MSPLINK** command to dynamically create a Multiple Systems Coupling (MSC) physical link between two MSC-enabled IMS systems.

Using the **CREATE MSPLINK** command, you can create any of the following types of MSC physical links:

- Channel to channel (CTC)
- Main storage to main storage (MTM)
- Transmission Control Protocol/Internet Protocol (TCP/IP)
- Virtual Telecommunications Access Method (VTAM)

You can define a maximum of 1018 physical links in an IMS system.

Subsections:

- [“Environment” on page 231](#)
- [“Syntax diagrams” on page 232](#)
- [“Keywords” on page 233](#)
- [“Usage notes” on page 236](#)
- [“Output fields” on page 237](#)
- [“Return and reason codes” on page 237](#)
- [“Completion codes” on page 239](#)
- [“Examples of the CREATE MSPLINK command” on page 240](#)

### Environment

The following table lists the environments (DB/BC, DBCTL, and DCCTL) from which the CREATE MSPLINK command and its keywords can be issued.

Table 143. Valid environments for the CREATE MSPLINK command and keywords

| Command / Keywords           | DB/DC | DBCTL | DCCTL |
|------------------------------|-------|-------|-------|
| CREATE MSPLINK NAME () SET() | X     |       | X     |

## Syntax diagrams

The syntax diagrams for each type of MSC physical link are shown separately.

### Syntax diagram for CTC physical links

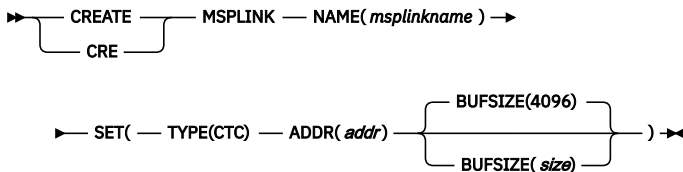

### Syntax diagram for MTM physical links

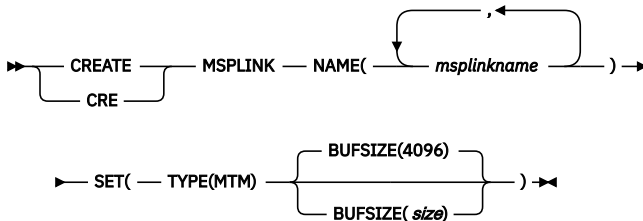

### Syntax diagram for TCPIP physical links

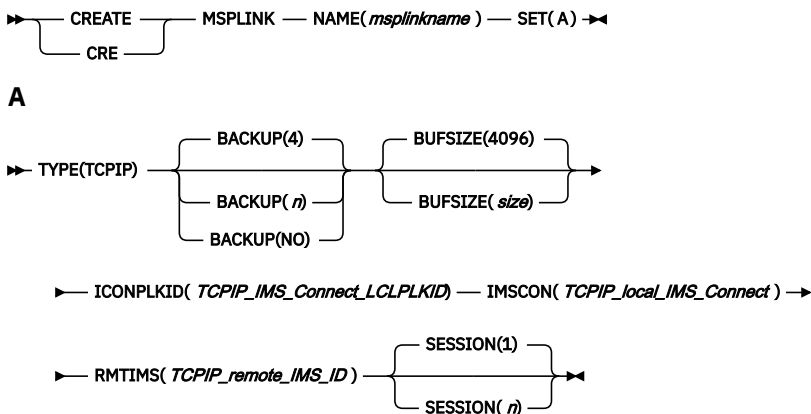

### Syntax diagram for VTAM physical links

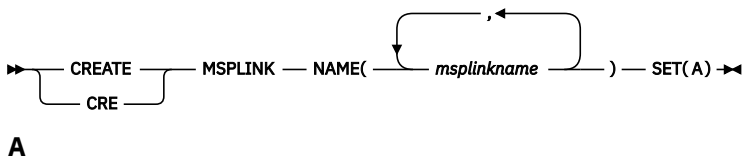

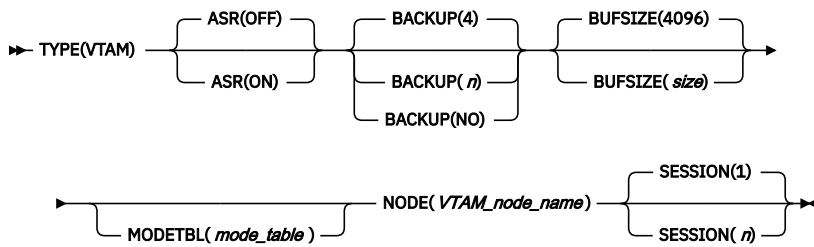

## Keywords

The following keywords are valid for the **CREATE MSPLINK** command:

### NAME

Specifies the 1- to 8-character name of the MSC physical link that is to be created.

For MTM and VTAM links, you can specify multiple names on the NAME keyword. When multiple names are specified, multiple physical links are created, one for each name specified. Other than the name, all of the physical links that are created this way will have the same attributes.

For CTC and TCP/IP links, only a single 1- to 8-character name can be specified on the NAME keyword, because only one CTC or TCP/IP physical link can be created at a time by the CREATE MSPLINK command. Certain attributes of CTC and TCP/IP physical links are unique to each physical link.

- For CTC links, the ADDR attribute must be unique among all CTC physical links.
- For TCP/IP physical links the ICONPLKID and IMSCON attribute pair must be unique among all TCP/IP physical links.
- Consequently, a set of CTC or TCP/IP physical links cannot be created with identical attributes.

Names must be alphanumeric (A - Z, 0 - 9, #, \$, and @). All MSPLINK names must begin with an alphabetic character (A - Z, #, \$, and @) followed by 0 - 7 alphanumeric characters.

Names cannot include a blank, comma, period, hyphen, or equal sign.

Names cannot begin with DFS, with the exception of DFSIVPxx and DFSSAMxx.

The following reserved words cannot be the name of a physical link:

- AFTER
- BASICEDT
- DBCDM
- DBRC
- FOR
- ISCEDT
- MSDB
- ON
- SDB
- SECURITY
- TO
- WTOR

The physical link name is used to assign a logical link to it. The physical link name can be changed by using the UPDATE MSPLINK command after it is created or defined in the system.

### SET()

Sets various attributes of the physical link. The required and optional attributes differ depending on the type of physical link that you are defining.

## **ADDR()**

Specifies the address of the channel-to-channel adapter. The address value can be three or four hexadecimal digits. This operand is required for CTC link types and is invalid for other link types.

All devices that are attached to the same channel as the CTC adapter must be accessible through an alternative channel. In addition, do not attach system resources (for example, paging devices) to the same channel as the CTC adapter.

The ADDR value must be unique among all CTC physical links defined in the IMS system.

You can change the value specified on the ADDR keyword by using the type-2 **UPDATE MSPLINK SET(ADDR(*addr*))** command.

## **ASR()**

Specifies the Automatic Session Restart option. This optional parameter applies only to VTAM links.

### **OFF**

Sets Automatic Session Restart off. The default is OFF.

### **ON**

For VTAM links that are supported by the VTAM session outage notification (SON) facility, sets Automatic Session Restart on.

For all logical links that are assigned to the physical link, the ASR specification on a physical link definition serves as the default ASR specification. The ASR specification on the physical link can be overridden in the definition of a logical link.

To display the current ASR option, you can use the type-2 command **QUERY MSLINK**. To change the current ASR option, you can use either of the following commands:

- The type-1 command **/CHANGE**
- The type-2 command **UPDATE MSPLINK NAME(*msplinkname*) SET(ASR(OFF|ON))**

ASR works only if both sides of the link are using the ASR option.

## **BACKUP()**

For XRF-capable IMS systems, controls the automatic restart of TCP/IP and VTAM links after an XRF takeover.

### ***n***

A numeric integer from 1 to 7 that sets the priority for reestablishing the session. The default is 4.

### **NO**

Specifying BACKUP=NO suppresses the automatic restart of the MSC physical link.

Although BACKUP prioritizes the order in which IMS restarts TCP/IP and VTAM links, the active requests might be completed in any order because of variables such as internal VTAM conflicts and pacing, and Internet Protocol network traffic.

You can change the value specified on the BACKUP keyword by using the type-2 **UPDATE MSPLINK SET(BACKUP(*n*|NO))** command.

BACKUP is an MSC physical link attribute that you can set by using the **CREATE MSPLINK**, **CREATE MSLINK**, or **UPDATE MSPLINK** command. You can display the physical link BACKUP value by using the **QUERY MSPLINK** and **QUERY MSLINK** commands.

**Important:** Even though BACKUP is a physical link attribute, the **CREATE MSLINK NAME(*linkname*) SET(MSPLINK(*msplinkname*))** command can also change the BACKUP value of the specified physical link. You can use the **QUERY MSPLINK** command to display the updated BACKUP value. You can also use the **QUERY MSLINK** command and specify the MSC logical links, including the newly created logical link, that are assigned to the physical link to display the updated BACKUP value.

## BUFSIZE()

Specifies the input and output buffer sizes for each logical link that is assigned to this physical link.

The valid range of buffer sizes for all link types is 1024 - 65536 bytes.

The same buffer size must be specified by the IMS systems at each end of a physical link.

IMS initializes the MSC link buffers to the size specified on the BUFSIZE parameter. If BUFSIZE is not specified, IMS uses a buffer size of 4096.

If you are using bandwidth mode, a BUFSIZE value of 1024 is too small to send multiple messages with one buffer. Specify a value of at least 4096.

You can change the size of a buffer of an individual logical link by using the **UPDATE MSLINK** NAME(*linkname*) SET(BUFSIZE(*new\_bufsize*)) or the **UPDATE MSPLINK** NAME(*linkname*) SET(BUFSIZE(*new\_bufsize*)) type-2 command. The BUFSIZE value for a physical link applies to logical links that are assigned to the physical link. The physical link does not have a buffer size. Specifically, the value is used to set the buffer size for logical links when they are later assigned to the physical link, but only if the logical links do not already have a buffer size.

## ICONPLKID()

For TCP/IP links, specifies the name that is used by IMS Connect to identify this physical link. The name that is specified on the ICONPLKID keyword of the **CREATE MSPLINK** command must match the name that is specified on the LCLPLKID parameter of the MSC statement that defines the physical link to the local IMS Connect instance that is managing TCP/IP communications for this link. The name that is specified on the ICONPLKID must start with an alphabetic character and can be 1 - 8 alphanumeric characters long.

ICONPLKID is a required keyword for TCP/IP physical links and it is invalid for other link types.

The ICONPLKID and IMSCON values must define a unique attribute pair among all TCP/IP physical links.

## IMSCON()

For TCP/IP links, specifies the IMSplex name of the local IMS Connect instance that manages TCP/IP communications for this physical link. The name that is specified on the IMSCON keyword must match the name that is specified on the MEMBER parameter of either the MSC statement or the IMSPLEX statement in the IMS Connect configuration PROCLIB member (HWSCFGxx). IMSplex names start with an alphabetic character and are 1- to 8-alphanumeric characters long.

The IMSCON keyword is required for TCP/IP physical links and is invalid for other link types.

You can use UPDATE MSPLINK command with the IMSCON keyword to switch the IMS Connect instance that an MSC physical link uses.

The ICONPLKID and IMSCON values must define a unique attribute pair among all TCP/IP physical links.

## MODETBL()

Specifies the name of the VTAM logon mode table entry (logon mode name) containing the SNA bind parameters to be used when a session is established for this terminal.

With MODETBL(), you can have a specification for referencing an entry other than the default entry in the user VTAM logon mode table. Normally, the mode table entry name is specified when a terminal operator logs on to a terminal; this result was not possible, however, from the IMS master terminal because IMS initiated the session.

If MODETBL= is not specified, no functional or operational change affects the user.

If MODETBL= is specified, the specified entry name is used.

You can display the current MODETBL name for each assigned logical link by using either the **/ DISPLAY LINK** command or the **QUERY MSLINK** command. You can override the MODETBL name by using:

- The LOGON APPLID entry by the remote terminal operator
- The **VARY ACT, LOGON=** command by the network terminal operator
- The **/RST** or the **/CHANGE** command by the master terminal operator
- Either the type-2 command **UPDATE MSPLINK** or **UPDATE MSLINK** through the Operations Manager API

The MODETBL= parameter is required for the IMS master terminal if the VTAM default mode table is not configured specifically for the device to be used as the IMS master terminal.

Specifying MODETBL on the **CREATE MSPLINK** command circumvents the requirement to specify the mode table entry when an operator logs on to a terminal that always requires the specification of the same mode table entry name.

If the terminal that is being defined is in another domain (that is, a cross-domain resource), the MODETBL() keyword does not need to be specified.

**Related reading:** For more information, see *z/OS Communications Server: SNA Programming*.

### **NODE()**

Specifies a 1- to 8-alphanumeric name for the remote VTAM node (APPLID) name for the VTAM line. The NODE() keyword is required for VTAM physical links.

This node is the VTAM node name of the remote IMS system at the other end of the link. This node is the label on the VTAM APPL statement for the remote IMS system. For an MSC VTAM link that is communicating with an XRF complex, the node name must be the VTAM USERVAR that is associated with the partner XRF complex.

You can change the value that is specified on the NODE() keyword by using the type-2 IMS command **UPDATE MSPLINK** command.

### **RMTIMS()**

Specifies the IMS ID of the remote IMS system that this physical link connects to. The remote IMS ID must be 1 to 8 alphanumeric characters.

RMTIMS is a required parameter for TCP/IP physical links and is invalid for other link types.

You can change the remote IMS system that an MSC physical link references by using the type-2 IMS command **UPDATE MSPLINK** command.

### **SESSION()**

For TCP/IP and VTAM physical link types only, specifies the number of parallel sessions that can be active for the physical link. Valid values are 1 - 1018. The default is 1.

If you specify a larger number than you currently need, you can dynamically assign more logical links to the physical link later.

Because a logical parallel session uses the same amount of storage for control blocks and buffers as a physical link, allocating many parallel sessions can use an excessive amount of common storage area. Predetermine how much common storage area you are likely to need.

You can change the value specified on the SESSION keyword by using the type-2 **UPDATE MSPLINK SET(SESSION(n))** command.

### **TYPE()**

Specifies the type of physical link that is being defined. Valid parameters are CTC, MTM, TCPIP, and VTAM.

With the MTM type link, you can connect IMS systems that are running in the same z/OS system without a hardware link.

## **Usage notes**



The **CREATE MSPLINK** command can be issued only through the Operations Manager API. These commands apply to DB/DC and DCCTL systems. The syntax for this command is defined in XML and is available to automation programs that communicate with OM.

When creating CTC links with the **CREATE MSPLINK** command, you do not need to specify a DDNAME for the JCL statement that describes the physical CTC connection. IMS creates the DDNAME dynamically by using the following naming convention: DFSMnnnn, where nnnn is the link number.

MSC physical link resources that are added by the CREATE MSPLINK command are logged to save them across warm and emergency restarts. If you dynamically created MSC physical link resources with the CREATE MSPLINK command and want to restore the definitions at the next IMS cold start, you must also perform one of the following actions:

- Export the resources to the IMSRSC repository by using the automatic export function and import the resources at IMS cold start by using the automatic import function.
- Define the resources with stage-1 system definition macros and regenerate the MSC resources into the DFSCLL3x member in the IMS.SDFSRESL data set.

## Output fields

The following table shows the **CREATE MSPLINK** output fields. The columns in the table are as follows:

### Short label

Contains the short label that is generated in the XML output.

### Keyword

Identifies keyword on the command that caused the field to be generated. N/A appears for output fields that are always returned. The value *error* appears for output fields that are returned only in case of an error.

### Meaning

Provides a brief description of the output field.

*Table 144. Output fields for the CREATE MSPLINK command*

| Short label | Long label | Keyword | Meaning   |
|-------------|------------|---------|---|
| CC          | CC         | N/A     | Completion code.  |
| CCTXT       | CCText     | N/A     | Completion code text that briefly explains the meaning of the non-zero completion code. |
| MBR         | Mbrname    | N/A     | IMSpIplex member that built the output line.  |
| MSP         | MSPLink    | N/A     | Physical link name.   |

## Return and reason codes

The OM return and reason codes that might be returned as a result of the **CREATE MSPLINK** command are standard for all commands that are entered through the OM.

The following table includes the return and reason codes and a brief explanation of the codes. The return or reason code returned for the command might also indicate an error from a CSL request.

*Table 145. Return and reason codes for the CREATE MSPLINK command*

| Return code | Reason code | Meaning   |
|-------------|-------------|---|
| X'00000000' | X'00000000' | The command completed successfully. The command output contains a line for each resource, which is accompanied by its completion code. See the completion code table for details. |

Table 145. Return and reason codes for the CREATE MSPLINK command (continued)

| Return code | Reason code | Meaning   |
|-------------|-------------|---|
| X'00000008' | X'00002152' | The ADDR keyword is required for TYPE(CTC).                                       |
| X'00000008' | X'00002153' | The ADDR keyword is supported only when TYPE(CTC) is specified.                   |
| X'00000008' | X'00002154' | Invalid ADDR value.   |
| X'00000008' | X'00002155' | The ASR keyword is not supported with the specified TYPE value.                   |
| X'00000008' | X'00002156' | The BACKUP keyword is supported only when TYPE(TCPIP) or TYPE(VTAM) is specified. |
| X'00000008' | X'00002157' | Invalid BACKUP value.   |
| X'00000008' | X'00002158' | Invalid BUFSIZE value.  |
| X'00000008' | X'00002159' | The ICONPLKID keyword is required when TYPE(TCPIP) is specified.                  |
| X'00000008' | X'0000215A' | Invalid ICONPLKID value.  |
| X'00000008' | X'0000215B' | The ICONPLKID keyword is not supported with the specified TYPE value.             |
| X'00000008' | X'0000215C' | The IMSCON keyword is required when TYPE(TCPIP) is specified.                     |
| X'00000008' | X'0000215D' | Invalid IMSCON value.   |
| X'00000008' | X'0000215E' | The IMSCON keyword is not supported with the specified TYPE value.                |
| X'00000008' | X'0000215F' | Invalid MODETBL value.  |
| X'00000008' | X'00002160' | The MODETBL keyword is not supported with the specified TYPE value.               |
| X'00000008' | X'00002161' | The NODE keyword is required when TYPE(VTAM) is specified.                        |
| X'00000008' | X'00002162' | Invalid NODE name.  |
| X'00000008' | X'00002163' | The NODE keyword is not supported with the specified TYPE value.                  |
| X'00000008' | X'00002164' | The NODE name cannot be the local VTAM node name.                                 |
| X'00000008' | X'00002165' | The TYPE keyword is not specified.  |
| X'00000008' | X'00002166' | The RMTIMS keyword is required when TYPE(TCPIP) is specified.                     |
| X'00000008' | X'00002167' | Invalid RMTIMS value.   |
| X'00000008' | X'00002168' | The RMTIMS keyword is not supported with the specified TYPE value.                |
| X'00000008' | X'00002169' | The RMTIMS value cannot be the same as the local system ID.                       |
| X'00000008' | X'0000216A' | Invalid SESSION value.  |
| X'00000008' | X'0000216B' | The SESSION keyword is not supported with the specified TYPE value.               |

Table 145. Return and reason codes for the CREATE MSPLINK command (continued)

| Return code | Reason code | Meaning  |
|-------------|-------------|--|
| X'0000000C' | X'00003000' | Command was successful for some resources but failed for others. The command output contains a line for each resource, which is accompanied by its completion code. See the completion code table for details. |
| X'0000000C' | X'00003004' | Command was not successful for any of the resources. The command output contains a line for each resource, which is accompanied by its completion code. See the completion code table for details.             |
| X'00000010' | X'0000400C' | Command is not valid on the XRF alternate.   |
| X'00000010' | X'0000402C' | Command is not valid because MSC is not enabled in the IMS system.   |
| X'00000010' | X'0000402D' | Command is not allowed because dynamic definition is not enabled for MSC. MSCRSCS=DYN is not specified in the MSC section of the DFSDFxxx member of the IMS PROCLIB data set.                                  |
| X'00000014' | X'00005004' | A DFSOCMD response buffer could not be obtained.   |
| X'00000014' | X'00005008' | DFSPPOOL storage could not be obtained.  |
| X'00000014' | X'00005010' | Unable to obtain latch.  |

## Completion codes

The following table includes an explanation of the completion codes.

Table 146. Completion codes for the CREATE MSPLINK command

| Completion code | Completion code text             | Meaning  |
|-----------------|----------------------------------|--|
| 0               |                                  | The command completed successfully for the physical link.  |
| 11              | RESOURCE ALREADY EXISTS          | A physical link with the same name already exists.   |
| 5F              | INVALID CHARACTERS IN NAME       | Name is invalid because it contains an invalid character.  |
| 60              | GETMAIN STORAGE ERROR            | A GETMAIN request for storage was unsuccessful.  |
| 61              | DFSBCB STORAGE ERROR             | DFSBCB storage error. Could not get storage for MSCP control block.  |
| 8A              | WILDCARD PARAMETER NOT SUPPORTED | The <b>CREATE</b> command does not support wildcard parameters. You must explicitly specify the names of the resources you want to create. |
| 90              | INTERNAL ERROR                   | An IMS system service failure.   |

Table 146. Completion codes for the CREATE MSPLINK command (continued)

| Completion code | Completion code text           | Meaning   |
|-----------------|--------------------------------|---|
| 93              | RESERVED NAME                  | Name is reserved. For example, name starts with DFS (except for DFSSAMxx or DFSIVPxx), or is an IMS reserved name such as BASICEDT or WTOR.           |
| 172             | FIRST CHAR MUST NOT BE NUMERIC | The specified parameter value cannot begin with a numeric character.  |
| 200             | NO DDNAME AVAILABLE FOR CRE    | All DDNAMEs from DFMS00000 to DFMS9999 are in use.  |
| 201             | UNABLE TO ALLOCATE DEVICE      | Dynamic allocation of CTC device failed.  |
| 202             | UNABLE TO OPEN CTC DEVICE      | CTC DCB open failed.  |
| 203             | ADDR IS NOT A CTC DEVICE       | The device at the specified address is not a CTC adapter.   |
| 204             | UNAVAILABLE CTC DEVICE         | The CTC device at the address specified on the ADDR parameter is not available.   |
| 205             | MSPLINK ITASK CREATE FAILED    | Creation of MSPLINK ITASK failed.   |
| 206             | CREATED LINK ENQUEUE FAILED    | ENQUEUE LCB TO HASH TABLE ERROR   |
| 208             | MAX LINK NUMBER REACHED        | The CREATE MSPLINK command failed because the maximum number of MSC physical links are already defined. A maximum of 1018 physical links are allowed. |

### Examples of the CREATE MSPLINK command

The following examples show the **CREATE MSPLINK** command creating different types of MSC physical links.

#### CTC example

The following example of the **CREATE MSPLINK** command defines an MSC physical link with the following attributes:

- A name of PLNKC001
- A link type of CTC
- A CTC adapter address of 211

TSO SPOC input:

```
CRE MSPLINK NAME(PLNKC001) SET(TYPE(CTC) ADDR(211))
```

TSO SPOC output:

```
MSPLink MbrName    CC CText
PLNKC001 IMS1      0
PLNKC001 IMS2     204 UNAVAILABLE CTC DEVICE
```

OM API input:

```
CMD(CRE MSPLINK NAME(PLNKC001) SET(TYPE(CTC) ADDR(211)))
```

OM API output:

```
<imsout>
<ctl>
<omname>OM10M </omname>
<omvsn>1.7.0</omvsn>
<xmlvsn>20 </xmlvsn>
<statime>2014.274 15:39:27.567620</statime>
<stotime>2014.274 15:39:27.586550</stotime>
<staseq>CDD6E96DA7304D87</staseq>
<stoseq>CDD6E96DABCF6209</stoseq>
<rqsttkn1>USRT011 10083927</rqsttkn1>
<rc>0200000C</rc>
<rsn>00003000</rsn>
<rsnmsg>CSLN023I</rsnmsg>
<rsntxt>At least one request was successful.</rsntxt>
</ctl>
<cmderr>
<mbr name="IMS2 ">
<typ>IMS </typ>
<styp>DBDC </styp>
<rc>0000000C</rc>
<rsn>00003004</rsn>
<rsntxt>No requests were successful</rsntxt>
</mbr>
</cmderr>
<cmd>
<master>IMS2 </master>
<userid>USRT011 </userid>
<verb>CRE </verb>
<kwd>MSPLINK </kwd>
<input>CREATE MSPLINK NAME(PLNKC001) SET(TYPE(CTC)ADDR(211)) </input>
</cmd>
<cmdrsphdr>
<hdr slbl="MSCP" llbl="MSPLink" scope="LCL" sort="a" key="1" scroll="no" len="8" dtype="CHAR" align="left" />
<hdr slbl="MBR" llbl="MbrName" scope="LCL" sort="a" key="2" scroll="no" len="8" dtype="CHAR" align="left" />
<hdr slbl="CC" llbl="CC" scope="LCL" sort="n" key="0" scroll="yes" len="4" dtype="INT" align="right" skipb="no" />
<hdr slbl="CCTXT" llbl="CCText" scope="LCL" sort="n" key="0" scroll="yes" len="*" dtype="CHAR" skipb="yes" align="left" />
</cmdrsphdr>
<cmdrspdata>
<rsp>MSCP(PLNKC001) MBR(IMS2 ) CC( 204) CCTXT(UNAVAILABLE CTC DEVICE) </rsp>
<rsp>MSCP(PLNKC001) MBR(IMS1 ) CC( 0) </rsp>
</cmdrspdata>
</imsout>
```

**Explanation:** The **CREATE MSPLINK** command is issued to create one MSC channel-to-channel physical link. The command is routed to both IMS1 and IMS2. The command fails on IMS2 with completion code 204, because that CTC address does not exist on IMS2. The command should have been routed only to IMS1. A DD name is not specified in the example because IMS generates the DDNAME automatically. The generated DCB DD names use the format *DFSMnnnn*, where *nnnn* is the link number.

### MTM example

The following example of the **CREATE MSPLINK** command defines an MSC physical link with the following attributes:

- A name of PLNKM001
- A link type of MTM
- A buffer size of 4096 (default)

TSO SPOC input:

```
CRE MSPLINK NAME(PLNKM001) SET(TYPE(MTM))
```

TSO SPOC output:

```
MSPLink  MbrName  CC
PLNKM001 IMS1     0
PLNKM001 IMS2     0
```

OM API input:

```
CMD(CRE MSPLINK NAME(PLNKM001) SET(TYPE(MTM)))
```

OM API output:

```
<imsout>
<ctl>
<omname>OM10M  </omname>
<omvsn>1.7.0</omvsn>
<xmlvsn>20 </xmlvsn>
<stime>2014.274 15:44:20.886013</stime>
<stotime>2014.274 15:44:20.901620</stotime>
<staseq>CDD6EA85621FD408</staseq>
<stoseq>CDD6EA8565EF440C</stoseq>
<rqsttkn1>USRT011 10084420</rqsttkn1>
<rc>00000000</rc>
<rsn>00000000</rsn>
</ctl>
<cmd>
<master>IMS2  </master>
<userid>USRT011 </userid>
<verb>CRE </verb>
<kwd>MSPLINK  </kwd>
<input>CREATE MSPLINK NAME(PLNKM001) SET(TYPE(MTM)) </input>
</cmd>
<cmdrsphdr>
<hdr slbl="MSCP" llbl="MSPLink" scope="LCL" sort="a" key="1" scroll="
no" len="8" dtype="CHAR" align="left" />
<hdr slbl="MBR" llbl="MbrName" scope="LCL" sort="a" key="2" scroll="no"
len="8" dtype="CHAR" align="left" />
<hdr slbl="CC" llbl="CC" scope="LCL" sort="n" key="0" scroll="yes"
len="4" dtype="INT" align="right" skipb="no" />
<hdr slbl="CCTXT" llbl="CCText" scope="LCL" sort="n" key="0"
scroll="yes" len="*" dtype="CHAR" skipb="yes" align="left" />
</cmdrsphdr>
<cmdrspdata>
<rsp>MSCP(PLNKM001) MBR(IMS2  ) CC( 0) </rsp>
<rsp>MSCP(PLNKM001) MBR(IMS1  ) CC( 0) </rsp>
</cmdrspdata>
</imsout>
```

**Explanation:** The **CREATE MSPLINK** command is issued to create one MSC memory-to-memory physical link. The command is routed to both IMS1 and IMS2 and the physical link is created on both IMS systems.

### TCPIP example

The following example of the **CREATE MSPLINK** command defines an MSC physical link with the following attributes:

- A name of PLNKT001
- A link type of TCPIP
- A buffer size of 4096 (default)

TSO SPOC input:

```
CRE MSPLINK NAME(PLNKT001) SET(TYPE(TCPIP)
ICONPLKID(MSC31) IMSCON(HWS3) RMTIMS(IMS2))
```

TSO SPOC output:

```
MSPLink MbrName CC
PLNKT001 IMS1 0
```

OM API input:

```
CMD(CRE MSPLINK NAME(PLNKT001)
SET(TYPE(TCPIP) ICONPLKID(MSC31) IMSCON(HWS3) RMTIMS(IMS2)))
```

OM API output:

```
<ctl>
<omname>OM10M </omname>
<omvsn>1.7.0</omvsn>
<xmlvsn>20 </xmlvsn>
<statime>2014.274 15:53:59.158782</statime>
<stotime>2014.274 15:53:59.159591</stotime>
<staseq>CDD6ECACDDFFEC16</staseq>
<stoseq>CDD6ECACDE327A16</stoseq>
<rqsttkn1>USRT011 10085359</rqsttkn1>
<rc>00000000</rc>
<rsn>00000000</rsn>
</ctl>
<cmd>
<master>IMS1 </master>
<userid>USRT011 </userid>
<verb>CRE </verb>
<kwd>MSPLINK </kwd>
<input>CREATE MSPLINK NAME(PLNKT001)
SET(TYPE(TCPIP) ,ICONPLKID(MSC31) ,IMSCON(HWS3) ,RMTIMS(IMS2)) </input>
</cmd>
<cmdrsphdr>
<hdr slbl="MSCP" llbl="MSPLink" scope="LCL" sort="a" key="1" scroll="
no" len="8" dtype="CHAR" align="left" />
<hdr slbl="MBR" llbl="MbrName" scope="LCL" sort="a" key="2" scroll="no"
len="8" dtype="CHAR" align="left" />
<hdr slbl="CC" llbl="CC" scope="LCL" sort="n" key="0" scroll="yes"
len="4" dtype="INT" align="right" skipb="no" />
<hdr slbl="CCTXT" llbl="CCText" scope="LCL" sort="n" key="0"
scroll="yes" len="*" dtype="CHAR" skipb="yes" align="left" />
</cmdrsphdr>
<cmdrspdata>
<rsp>MSCP(PLNKT001) MBR(IMS1 ) CC( 0) </rsp>
</cmdrspdata>
</imsout>
```

**Explanation:** The **CREATE MSPLINK** command is issued to create one MSC TCP/IP physical link on IMS1. MSC31 is the name that is used by IMS Connect to identify this physical link. HWS3 is the IMSplex name of the local IMS Connect instance that is providing TCP/IP support. IMS2 is the ID of the remote, partner IMS system.

### VTAM example

The following example of the **CREATE MSPLINK** command defines an MSC physical link with the following attributes:

- A name of PLNKV001
- A link type of VTAM
- A buffer size of 4096 (default)
- A partner IMS system that is defined to VTM as node L6APPL1
- A maximum session number of 1 (default).

TSO SPOC input:

```
CRE MSPLINK NAME(PLNKV001) SET(TYPE(VTAM) NODE(L6APPL1))
```

TSO SPOC output:

```
MSPLink MbrName CC
PLNKV001 IMS1 0
```

OM API input:

```
CMD(CRE MSPLINK NAME(PLNKV001) SET(TYPE(VTAM) NODE(L6APPL1)))
```

OM API output:

```
<imsout>
<ctl>
<omname>OM10M </omname>
<omvsn>1.7.0</omvsn>
<xmlvsn>20 </xmlvsn>
<statime>2014.274 14:45:08.904435</statime>
<stotime>2014.274 14:45:08.913582</stotime>
<staseq>CDD6DD49F31F3F8A</staseq>
<stoseq>CDD6DD49F55AE188</stoseq>
<rqsttkn1>USRT011 10074508</rqsttkn1>
<rc>00000000</rc>
<rsn>00000000</rsn>
</ctl>
<cmd>
<master>IMS1 </master>
<userid>USRT011 </userid>
<verb>CRE </verb>
<kwd>MSPLINK </kwd>
<input>CREATE MSPLINK NAME(PLNKV001) SET(TYPE(VTAM),NODE(L6APPL1))
</input>
</cmd>
<cmdrsphdr>
<hdr slbl="MSCP" llbl="MSPLink" scope="LCL" sort="a" key="1" scroll="
no" len="8" dtype="CHAR" align="left" />
<hdr slbl="MBR" llbl="MbrName" scope="LCL" sort="a" key="2" scroll="no"
len="8" dtype="CHAR" align="left" />
<hdr slbl="CC" llbl="CC" scope="LCL" sort="n" key="0" scroll="yes"
len="4" dtype="INT" align="right" skipb="no" />
<hdr slbl="CCTXT" llbl="CCText" scope="LCL" sort="n" key="0"
scroll="yes" len="*" dtype="CHAR" skipb="yes" align="left" />
</cmdrsphdr>
<cmdrspdata>
<rsp>MSCP(PLNKV001) MBR(IMS1 ) CC( 0) </rsp>
</cmdrspdata>
</imsout>
```

**Explanation:** The **CREATE MSPLINK** command is issued to create one MSC VTAM physical link on IMS1 with remote VTAM node (APPLID) name of L6APPL1.

## CREATE OTMADESC command

Use the **CREATE OTMADESC** command to create an OTMA destination descriptor without restarting IMS.

Subsections:

- [“Environment” on page 244](#)
- [“Syntax” on page 245](#)
- [“Keywords” on page 246](#)
- [“Usage notes” on page 250](#)
- [“Output fields” on page 251](#)
- [“Return, reason, and completion codes” on page 251](#)
- [“Examples” on page 253](#)

### Environment

The following table lists the environments (DB/DC, DBCTL, and DCCTL) in which you can use the commands and keywords.



Table 147. Valid environments for the CREATE OTMADESC command and keywords

| Command / Keywords     | DB/DC | DBCTL | DCCTL |
|------------------------|-------|-------|-------|
| <b>CREATE OTMADESC</b> | X     |       | X     |
| NAME                   | X     |       | X     |
| SET                    | X     |       | X     |

## Syntax

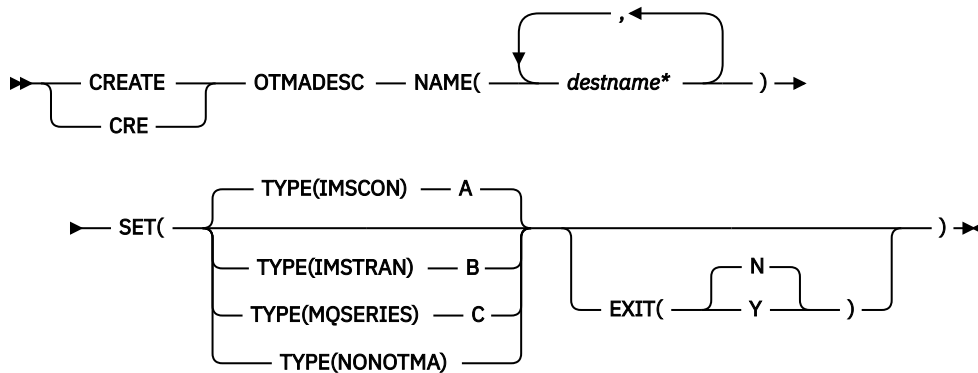

### A (TYPE=IMSCON)

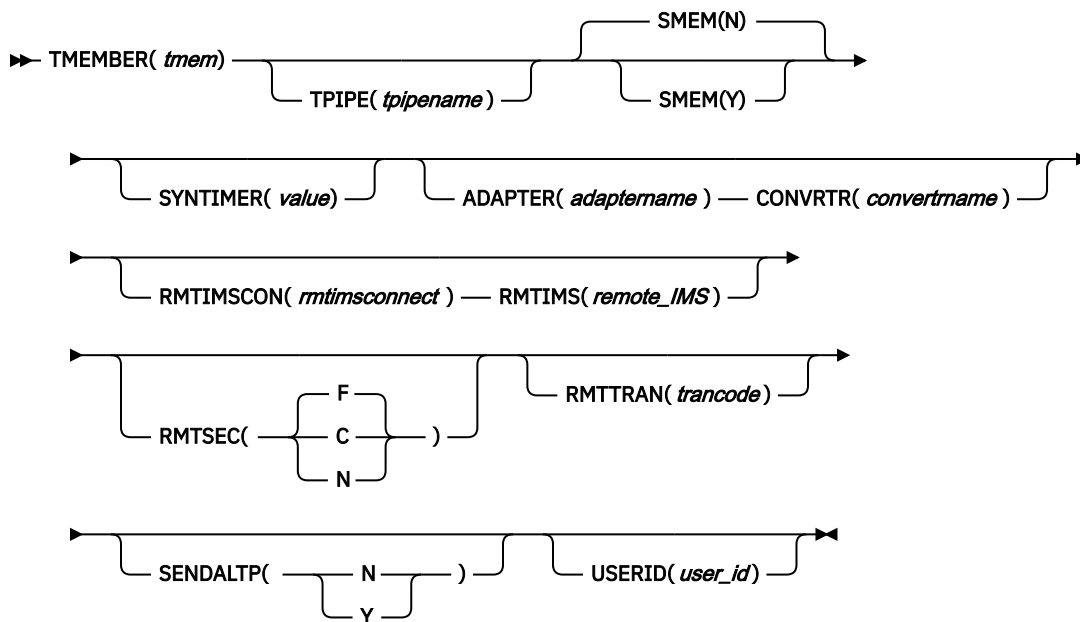

### B (TYPE=IMSTRAN)

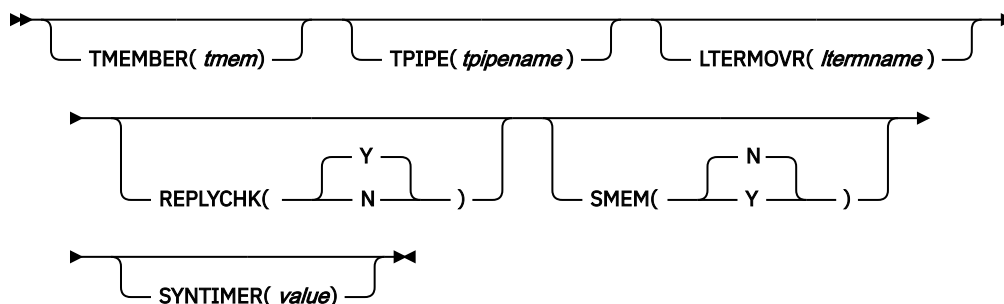

## C (TYPE=MQSERIES)

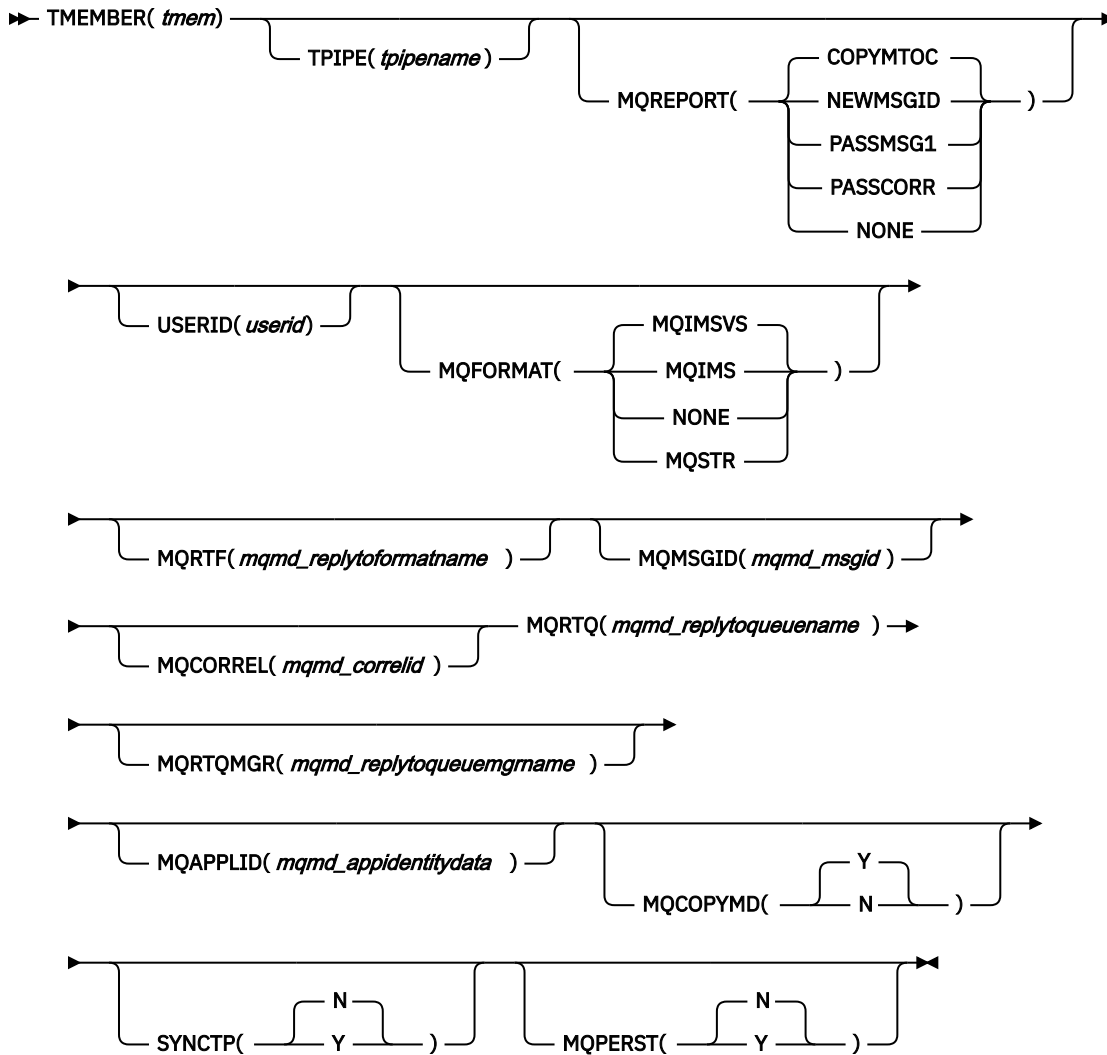

## Keywords

The following keywords are valid for the **CREATE OTMADESC** command:

### **ADAPTER**(*adaptername*)

An optional keyword for TYPE(IMSCON). The *adaptername* is a 1- to 8-character name that identifies the IMS Connect adapter. If TYPE(NONOTMA) is specified, you cannot specify this keyword.

### **CONVRTR**(*convertname*)

A required parameter only if the ADAPTER keyword is specified. The *convertname* is a 1- to 8-character converter name used by the adapter. Coding this keyword without the ADAPTER keyword or with TYPE(NONOTMA) will cause an error.

### **EXIT**(**N|Y**)

When TYPE=IMSTRAN, this is an optional parameter used to indicate whether the IMS user exit (DFSCMUX0) can override the descriptor routing information for late messages.

For other descriptor types, this is an optional parameter used to specify whether the OTMA routing exits (DFSYPX0 and DFYDRU0) can override the descriptor switch destination from ALT IOPCB.

### **LTERMOVR**(*ltermname*)

When TYPE=IMSTRAN, this is an optional parameter used to specify a logical terminal name that overrides the name that is specified in the application I/O PCB. If an override name is also specified in

the AIBRSNM2 field of the AIB, that name is used instead of the name in the descriptor. If neither the descriptor or the AIB contains an override name, the IMS application terminal symbolic (PSTSYMB0) is used as the default logical terminal name for the target transaction.

**MQAPPLID(mqmd\_appidentitydata)**

When TYPE=MQSERIES, this is an optional parameter that specifies a 1- to 32-character value for the MQMD\_APPLIDENTITYDATA field. This field is used to pass data to the receiving IBM MQ application. The default is 32 blanks.

**MQCOPYMD(Y | N)**

When TYPE=MQSERIES, this is an optional parameter that specifies whether the original input values of the MQMD data structure from the MQ IMS Bridge are copied to the output message.

**MQCORREL(mqmd\_correlid)**

When TYPE=MQSERIES, this is an optional parameter that specifies a 1- to 24-character value for the MQMD\_CORRELID field. This value is passed directly to the receiving IBM MQ application if the value of the MQREPORT parameter is PASSCORR. The default is 0.

**MQFORMAT(MQIMSVS | MQIMS | NONE | MQSTR)**

When TYPE=MQSERIES, this is an optional parameter that specifies value for the MQMD\_FORMAT field. The default value is MQIMSVS.

**MQMSGID(mqmd\_msgid)**

When TYPE=MQSERIES, this is an optional parameter that specifies a 1- to 24-character value for the MQMD\_MSGID field. This value is passed directly to the receiving IBM MQ application if the value of the MQREPORT parameter is PASSMSG1.

**MQPERST(N | Y)**

When TYPE=MQSERIES, this is an optional parameter that specifies whether messages that use this descriptor are persistent on a SYNC TPIPE. Setting this parameter to Y is analogous to setting X'40' for the output flag value of the DFSYDRU0 exit routine.

**MQREPORT(COPYMTOC | NEWMSGID | PASSMSG1 | PASSCORR | NONE)**

When TYPE=MQSERIES, this is an optional parameter that specifies the MQMD\_REPORT field value for messages that use the descriptor. The default value is COPYMTOC. Each supported value corresponds to an equivalent value in the MQMD data structure:

**Parameter value**

**Equivalent MQMD structure value**

**NEWMSGID**

MQRO\_NEW\_MSG\_ID

**PASSMSGI**

MQRO\_PASS\_MSG\_ID

**COPYMTOC**

MQRO\_COPY\_MSG\_ID\_TO\_CORREL\_ID

**PASSCORR**

MQRO\_PASS\_CORREL\_ID

**PASSMSCO**

MQRO\_PASS\_MSG\_ID and MQRO\_PASS\_CORREL\_ID

**NONE**

MQRO\_NONE

**MQRTF(mqmd\_replytoformat)**

When TYPE=MQSERIES, this is a 1- to 8-character value for the MQMD\_REPLYTOFORMAT field. The default is 0.

**MQRTQ(mqmd\_replytoqueueenname)**

When TYPE=MQSERIES, this is a required parameter that specifies a 1- to 48-character value for the MQMD\_REPLYTOQ field.

**MQRTQMGR(mqmd\_replytoqueueanagername)**

When TYPE=MQSERIES, this is an optional parameter that specifies a 1- to 48-character value for the MQMD\_REPLYTOQMGR field. If this parameter is not specified, MQSeries® will use the local queue manager.

**NAME(destname\*)**

A required keyword parameter that specifies a 1- to 8-character destination name. The destination name can have an asterisk (\*) at the end to mask groups of names. An asterisk by itself is a valid name and is an entry in the table of destination routing descriptors. A masked name that encompasses another masked name does not have to be created in the order from most specific to most generic. However, the search order starts from the most specific to the most generic.

Creating a destination name that already exists in the system is an error.

**REPLYCHK(Y|N)**

Specifies whether an IMS application replies to the IOPCB for a synchronous program switch request. When REPLYCHK=YES and the ICAL target application does not reply to the IOPCB or switch to another transaction, IMS gives the error return code X'0100', with reason code X'0110', and extended reason code X'0016' instead of a timeout to the ICAL call. The default is Y.

**RMTIMS**

An optional 1- to 8-character name of a remote, destination IMS system for ALTPCB output messages. When RMTIMS is specified, you must also specify the RMTIMSCON parameter. The RMTIMS value must match the value specified on the ID parameter of a DATASTORE statement in the configuration member of the remote IMS Connect instance. This parameter is valid only when TYPE(IMSCON) is specified.

**RMTIMSCON**

An optional 1- to 8-character name of a connection to a remote IMS Connect instance, as defined on ID parameter of the RMTIMSCON statement in the HWSCFGxx PROCLIB member of the local IMS Connect. When RMTIMSCON is specified, you must also specify RMTIMS. This parameter is valid only when TYPE(IMSCON) is specified.

**RMTSEC(F | C | N)**

An optional parameter that sets the security flag in the OTMA ALTPCB output message that is sent to a remote IMS system through IMS-to-IMS TCP/IP communications. The remote IMS system uses this security flag setting in the output message only if the input message does not have a security flag and the remote IMS OTMA security is set to PROFILE

The default is RMTSEC(F). This parameter is valid only when TYPE(IMSCON) is specified.

**F**

OTMA RACF security is set to FULL.

**C**

OTMA RACF security is set to CHECK.

**N**

OTMA RACF security is set to NONE.

**RMTRAN**

An optional 1- to 8-character name of the transaction to use at the remote, destination IMS system. When this parameter is specified with RMTIMSCON and RMTIMS parameters, OTMA passes the transaction code to IMS Connect, which inserts it into the outgoing message. This parameter is valid only when TYPE(IMSCON) is specified.

**SENDALTP(N | Y)**

An optional parameter that specifies whether the IMS system sends an ALTPCB output back to its initiating IMS Connect client. This parameter is valid only when TYPE(IMSCON) is specified.

The following values are valid on the SENDALTP parameter:

**Y**

IMS sends any ALTPCB output that is initiated by an IMS Connect commit-then-send send-receive call back to the originating IMS Connect client.

## N

IMS keeps any ALTPCB output for IMS Connect in a tpipe hold queue. The output message can be retrieved by a RESUME TPIPE request. If the SENDALTP function is activated at the member or datastore level and SENDALTP(N) is specified in the destination descriptor, the message level setting through OTMA destination descriptor overrides the member level setting. The ALTPCB output is then queued in a tpipe hold queue.

### SMEM(N | Y)

An optional parameter that can either be a Y or N value to indicate whether the TMEMBER name that is specified in the TMEMBER parameter is a super member. If the TMEMBER name is a super member, the length of the TMEMBER name has a maximum of 4 characters. SMEM and TYPE(NONOTMA) are mutually exclusive.

### SYNCTP(N | Y)

When TYPE=MQSERIES, this parameter specifies whether a SYNC TPIPE must be created for messages that use this descriptor. Setting this parameter to Y is analogous to setting X'80' for the output flag value of the DFSYDRU0 exit routine.

### SYNTIMER=value

An optional parameter that specifies the timeout value for a synchronous callout process. When the timeout value is reached, the IMS application that issues the synchronous callout request receives a X'100' return code and a X'104' reason code. The message is discarded.

If **TYPE=NONOTMA** or **TYPE=MQSERIES** is specified in the OTMA destination descriptor, or when the descriptor is used to route a non-synchronous callout message, this parameter is ignored. If **TYPE=IMSTRAN** is specified, this parameter is the timeout value for synchronous program switch ICAL calls.

The value of this parameter should be expressed in 100th of the timeout value in seconds. The valid range is 0–999999. The system default is 10 seconds. If you specify a value that is not within the valid range:

- If **SYNTIMER=0**, the system default is used.
- If the **SYNTIMER** value is larger than 999999, you'll receive error message DFS2385E. No default value is set.

The **AIBRSFLD** parameter in the DL/I ICAL SENDRECV call can override the **SYNTIMER** value when specified. Depending on the specification of the two parameters, the timeout value might vary:

- When the **AIBRSFLD** parameter is set:
  - If the **SYNTIMER** parameter is set, the smaller value is used.
  - If the **SYNTIMER** parameter is not set or is invalid, the **AIBRSFLD** value is used.
- When the **AIBRSFLD** parameter is not set or is invalid:
  - If the **SYNTIMER** parameter is set, the value of this parameter is used.
  - If the **SYNTIMER** parameter is not set or is invalid, the system default 10 seconds is used.

For more information about the usage of the **AIBRSFLD** parameter, see [ICAL call \(Application Programming APIs\)](#).

### TMEMBER(tmemb)

A required parameter for TYPE(IMSCON). The *tmemb* value is a 1- to 16-character OTMA TMEMBER name. Coding this keyword with TYPE(NONOTMA) causes an error. If SMEM(Y) is specified, *tmemb* is a maximum of 4-character super member name.

An optional parameter for TYPE(IMSTRAN). The *tmemb* value is a 1- to 16-character OTMA TMEMBER name. IMS queues late responses from a synchronous program switch to this OTMA TMEMBER. The destination name is used as the default OTMA TPIPE name if the TPIPE parameter is not specified in the descriptor.

**TPIPE(tpipename)**

An optional parameter that is a 1- to 8-character TPIPE name when TYPE(IMSCON) is specified. If this keyword is not coded, the TPIPE name is the destination name that is specified in the NAME keyword. This keyword is not valid if TYPE(NONOTMA) is specified. If the TPIPE is not coded and the NAME is a mask, the TPIPE will be a specific destination name that matched the mask in the table of destination routing descriptors and not the NAME keyword.

An optional parameter for TYPE(IMSTRAN) that specifies a 1- to 8-character TPIPE name. This parameter defaults to the destination name. IMS queues late responses from a synchronous program switch to this OTMA TPIPE. A value for the TMEMBER parameter is required when TPIPE is specified.

**TYPE(IMSCON | IMSTRAN | MQSERIES | NONOTMA)**

Specifies the type of destination:

**IMSCON**

An IMS Connect client. This is the default value.

**IMSTRAN**

An IMS transaction.

**MQSERIES**

IBM MQ.

**NONOTMA**

A non-OTMA destination. Only the EXIT parameter is valid with this descriptor type.

**USERID(userid)**

For TYPE=IMSCON, this is an optional 1- to 8-character RACF user ID. When this parameter is specified with RMTIMSCON, RMTTRAN, and RMTIMS parameters, a remote, destination IMS system uses the USERID value to perform transaction authorization. The value of USERID specified in the OTMA destination descriptor overrides the user ID provided by the IMS application program that issued the ISRT call to the OTMA ALTPCB. This parameter is valid only when TYPE(IMSCON) is specified.

For TYPE=MQSERIES, this is a 1- to 8-character user ID that corresponds with the MQMD\_USERIDENTIFIER field in the MQMD data structure. This field allows the OTMA descriptor to override the default user ID in the MQMD structure. Specify the value \*USERID\* to use the IMS user ID value from the PST.

**Usage notes**

The **CREATE OTMADESC** command is used to facilitate the creation of OTMA destination descriptors while IMS is up and running. The user can add new routing descriptors dynamically in addition to the statically defined destination routing descriptors in DFSYDTx of IMS.PROCLIB. The order in which the destination routing descriptors are coded is unrestricted and need not be coded in the order from most specific to most generic destination routing descriptor name. However, the search order in the table of destination routing descriptors will be performed from most specific to most generic.

**Note:** Note the distinction between the coding in DFSYDTx and the search order that is performed internally in the table of destination routing descriptors. In DFSYDTx, the rule of coding does not require the order from most specific to most generic; however, the search order in the table of destination routing descriptor is performed from most specific to most generic.

The destination routing descriptors are part of the checkpoint records used for persistency on IMS restart. Also, all **CREATE OTMADESC** commands will generate log records. The checkpoint log record is X4035 and the log record for CREATE, DELETE, and UPDATE is X221B. During an IMS warm restart, the destination routing descriptors will be rebuilt based on the checkpoint records. In case of an ERE restart, the log records will be used to completely rebuild the destination routing descriptors after the checkpoint records have been processed. Because of the rebuilding process, the routing descriptors in member DFSYDTx in PROCLIB will not be read and processed. However, during cold start processing, the routing descriptors in member DFSYDTx will be read and processed.

The **CREATE OTMADESC** command is not valid in an XRF alternate or an FDBR region environment. The checkpoint and log records will be used to update the destination routing descriptors in these environments. The **CREATE OTMADESC** command becomes a valid command only when the XRF alternate environment becomes the active IMS environment.

## Output fields

The following table shows the **CREATE OTMADESC** output fields. The columns in the table are:

### Short label

Contains the short label generated in the XML output.

### Long label

Contains the column heading for the output field in the formatted output.

### Keyword

Identifies the keyword on the command that caused the field to be generated. N/A appears for output fields that are always returned. *error* appears for output fields that are returned only in case of an error.

### Meaning

Provides a brief description of the output field.

*Table 148. Output fields for the CREATE OTMADESC command*

| Short label | Long label | Keyword | Meaning  |
|-------------|------------|---------|--|
| CC          | CC         | N/A     | Completion code for the line of output. The completion code indicates whether IMS was able to process the command for the specified resource. See <a href="#">“Return, reason, and completion codes”</a> on page 251 for more information. The completion code is always returned. |
| CCTXT       | CCText     | N/A     | Completion code text that briefly explains the meaning of the non-zero completion code. This field is returned only for an error completion code.  |
| DEST        | DestName   | NAME    | Destination name.  |
| MBR         | MbrName    | N/A     | Member name.   |

## Return, reason, and completion codes

An IMS return and reason code is returned to OM by the **CREATE OTMADESC** command. The OM return and reason codes that might be returned as a result of the **CREATE OTMADESC** command are standard for all commands entered through the OM API.

The following table includes the return and reason codes and a brief explanation of the codes. The return or reason code returned for the command might also indicate an error from a CSL request.

*Table 149. Return and reason codes for the CREATE OTMADESC command*

| Return code | Reason code | Meaning   |
|-------------|-------------|---|
| X'00000000' | X'00000000' | Command completed successfully. The command output contains a line for each resource, accompanied by its completion code. See the completion codes table for details. |
| X'02000008' | X'00002000' | The command contains an invalid verb or no client is registered for the verb.   |

Table 149. Return and reason codes for the CREATE OTMADESC command (continued)

| Return code | Reason code | Meaning   |
|-------------|-------------|---|
| X'02000008' | X'00002004' | The command contains an invalid primary keyword or no client is registered for the keyword. |
| X'02000008' | X'00002028' | The command contains an invalid keyword.  |
| X'02000008' | X'0000202C' | The command contains an unknown positional parameter.                                       |
| X'02000008' | X'00002034' | The command contains an incomplete keyword parameter.                                       |
| X'02000008' | X'00002038' | The command is missing a required parameter.  |
| X'02000008' | X'0000203C' | The command contains an invalid keyword parameter value.                                    |

The following table includes an explanation of the completion codes. Errors unique to the processing of this command are returned as completion codes. A completion code is returned for each action against an individual resource.

Table 150. Completion codes for the CREATE OTMADESC command

| Completion code | Completion code text             | Meaning   |
|-----------------|----------------------------------|---|
| 0               | Command completed successfully   | The <b>CREATE OTMADESC</b> command completed successfully for the resource.   |
| 153             | Adapter blank, Convrtr not blank | Both ADAPTER() and CONVRTR() keywords must be either both blanks or both contain valid names.                       |
| 154             | Adapter not blank, Convrtr blank | Both ADAPTER() and CONVRTR() keywords must be either both blanks or both contain valid names.                       |
| 155             | NONOTMA, other parms specified   | For TYPE(NONOTMA), no other keywords must be specified, such as TYPE(), TMEMBER(), SMEM(), ADAPTER(), or CONVRTR(). |
| 156             | SMEM=Y, super mbr name GT 4 char | For SMEM(Y), the TMEMBER value must not be greater than 4 characters.   |
| 157             | SMEM=Y, Tmember parm not specfd  | The TMEMBER keyword is a required parameter when SMEM(Y) is specified.  |
| 159             | TMEMBER is required              | A value for the TMEMBER keyword must be specified.  |
| 162             | Descriptor already exist in tbl  | The descriptor being created already exists in the table of destination routing descriptors.                        |
| 167             | SYNTIMER must have numeric value | The timeout value must have a value expressed in numbers within parenthesis.  |
| 169             | SYNTIMER has nonnumeric value    | The value must not contain alphabetic characters or any character that is not numeric.                              |



Table 150. Completion codes for the CREATE OTMADESC command (continued)

| Completion code | Completion code text              | Meaning   |
|-----------------|-----------------------------------|---|
| 16A             | RmtIMSCon blank, RmtIMS not blank | The RMTIMS and RMTIMSCON keywords were specified on the <b>CREATE OTMADESC</b> command, but no value was entered for RMTIMSCON. When a value is specified on the RMTIMS keyword, a value must also be specified on the RMTIMSCON keyword. |
| 16B             | RmtIMSCon not blank, RmtIMS blank | The RMTIMS and RMTIMSCON keywords were specified on the <b>CREATE OTMADESC</b> command, but no value was entered for RMTIMS. When a value is specified on the RMTIMSCON keyword, a value must also be specified on the RMTIMS keyword.    |
| 174             | Invalid parms for IMSTRAN         | An invalid keyword was specified for TYPE(IMSTRAN).   |
| 177             | Invalid parms for MQSeries        | An invalid keyword was specified for TYPE(MQSERIES).  |

### Examples

The following are examples of the **CREATE OTMADESC** command:

#### Example 1 for CREATE OTMADESC command

TSO SPOC input:

```
CREATE OTMADESC NAME(OTMACL*) SET(TYPE(IMSCON) TMEMBER(HWS2))
```

TSO SPOC output:

```
DestName  MbrName  CC
OTMACL*   IMSA     0
```

**Explanation:** In the example, the **CREATE OTMADESC** command is issued with NAME(OTMACL\*) and the descriptor OTMACL\* is included in the table of destination routing descriptors.

#### Example 2 for CREATE OTMADESC command

TSO SPOC input:

```
CREATE OTMADESC NAME(OTMACL99) SET(TYPE(IMSCON) TMEMBER(HWS1) TPIPE(HWS1TP01))
```

TSO SPOC output:

```
DestName  MbrName  CC
OTMACL99  IMSA     0
```

**Explanation:** If the **CREATE OTMADESC** command is issued with the TPIPE keyword, the descriptor OTMACL99 is included in the table of destination routing descriptors. Although not shown in the example, a **CREATE** command issued for OTMACL\* would be ahead of the CREATE for OTMACL99.

#### Example 3 for CREATE OTMADESC command

TSO SPOC input:

```
CREATE OTMADESC NAME(OTMACL01) SET(TYPE(IMSCON) TMEMBER(ICON1)
RMTIMSCON(ICON2) RMTIMS(IMS2) RMTTRAN(TRAN01) USERID(USER01))
```

TSO SPOC output:

| DestName | MbrName | CC |
|----------|---------|----|
| OTMACL01 | IMS1    | 0  |

**Explanation:** The **CREATE OTMADESC** command shown in this example creates an OTMA destination descriptor called OTMACL01 that routes ALTPCB output messages to a remote IMS system via a TCP/IP connection between two instances of IMS Connect. The command also defines the following values on the OTMA destination descriptor:

- The local instance of IMS Connect, as specified by TMEMBER(ICON1).
- The remote IMS Connect connection, as specified by RMTIMSCON(ICON2) in the local IMS Connect configuration member. This value is also specified on the ID parameter of the RMTIMSCON configuration statement of the local IMS Connect instance.
- The remote IMS system, as specified by RMTIMS(IMS2).
- The transaction to schedule at the remote IMS system, as specified by RMTTRAN(TRAN01).
- The user ID to be used for transaction authorization at the remote IMS system, as specified by USERID(USER01).

When the OTMA messages reach IMS2, IMS2 schedules TRAN01 to process the messages. The descriptor OTMACL01 is included in the table of destination routing descriptors.

### Related concepts

[How to interpret CSL request return and reason codes \(System Programming APIs\)](#)

### Related tasks

[Specifying a remote transaction code \(Communications and Connections\)](#)

### Related reference

[“Command keywords and their synonyms” on page 59](#)

All IMS command keywords and their synonyms, as well as keywords supported by the OM API, are listed. The list covers command keywords for the OM command processing clients such as IMS, ODBM, IMSCON, and RM.

## CREATE PGM command

Use the **CREATE PGM** command to define the program resource requirements for application programs that run under the control of the DB/TM environment, as well as for application programs that access databases through DBCTL.

The program resource describes an application program that operates in a message processing region, Fast Path message-driven program region, batch processing region, batch message processing region, or CCTL threads. Program resources combined with transactions define the scheduling and resource requirements for a message-driven application program.

Subsections:

- [“Environment” on page 255](#)
- [“Syntax” on page 255](#)
- [“Keywords” on page 256](#)
- [“Usage notes” on page 259](#)
- [“Output fields” on page 260](#)
- [“Return, reason, and completion codes” on page 260](#)
- [“Examples” on page 263](#)

## Environment

The following table lists the environments (DB/DC, DBCTL, and DCCTL) in which you can use the command and keywords.

Table 151. Valid environments for the CREATE PGM command and keywords

| Command / Keywords | DB/DC | DBCTL | DCCTL |
|--------------------|-------|-------|-------|
| CREATE PGM         | X     | X     | X     |
| LIKE               | X     | X     | X     |
| NAME               | X     | X     | X     |
| SET                | X     | X     | X     |

## Syntax

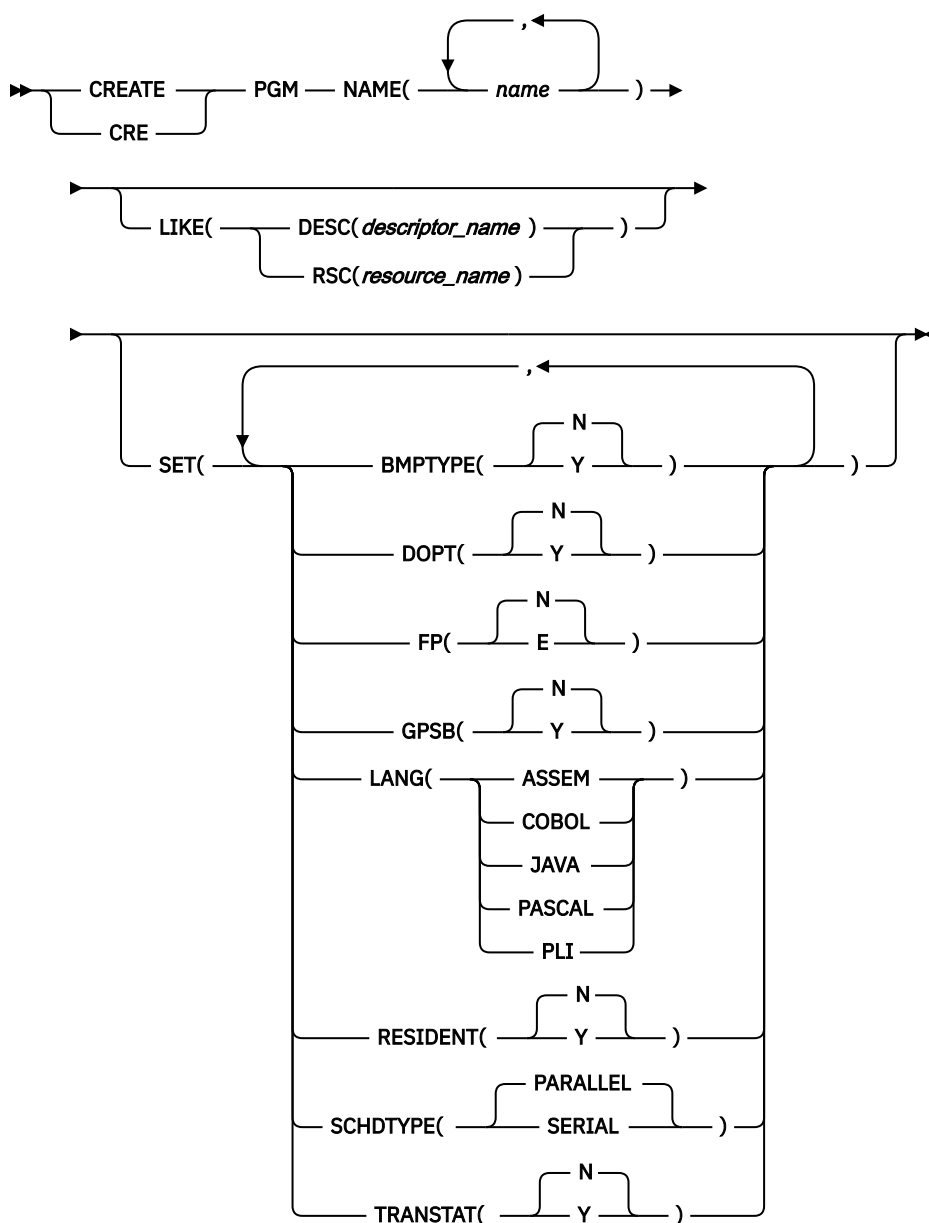

Default values shown in this syntax diagram reflect the default values that are defined in the IMS program descriptor, DFSDSPG1. If you define another descriptor as the default with a **CREATE** or **UPDATE PGMDESC** command, the default values shown in this syntax diagram might not match the value defined in the current default descriptor.

## Keywords

The following keywords are valid for the **CREATE PGM** command:

### LIKE

Specifies that the resource is created using an existing resource or descriptor as a model, instead of the default descriptor. The default descriptor is either the IMS descriptor DFSDSPG1, or user-defined. The model type can either be a descriptor (DESC), or a resource (RSC). The new resource is created with all the same attributes as the model. Attributes set explicitly by the **CREATE** command override the model attributes. Later changes to the model are not propagated to resources or descriptors that were created from it.

The **QUERY** commands can be used to display the model name and model type used to create the resource. The model name and type returned from the **QUERY** command are provided for informational purposes only. The **EXPORT** command exports a resource definition, including the model name and model type, to the definition member. The **IMPORT** command imports a resource definition, including the model name and model type, from the definition member. An **IMPORT** command that creates a resource saves the model name and model type, but does not use the models attributes.

#### **DESC(descriptor\_name)**

Specifies the name of the descriptor to use as a model to define this resource.

#### **RSC(resource\_name)**

Specifies the name of the resource to use as a model to define this resource.

### NAME

Specifies the 1-8 character name of the program. Names must be alphanumeric (A through Z, 0 through 9, #, \$, and @). All program names must begin with an alphabetic character (A through Z, #, \$, and @) followed by zero to seven alphanumeric characters. Names cannot include a blank, comma, period, hyphen, or equal sign. Names cannot begin with DFS, except for DFSIVPxx and DFSSAMxx. Names cannot be BASICEDT, DBCDM, DBF#FPU0, DBRC, ISCEDT, MSDB, SDB, or WTOR. Each local program name must be unique. If the program is defined with BMPTYPE(N) and FP(N), the program name and associated PSB name must be the same. A program resource and a program descriptor can have the same name.

### SET

Specifies the attributes of the program to be created. If the LIKE keyword is omitted, attributes not specified take the value defined in the default descriptor, which is either IMS descriptor DFSDSPG1 or user-defined. If the LIKE keyword is specified, attributes not specified take the value defined in the model.

#### **BMPTYPE()**

BMP type option. Specifies whether the program executes in a BMP type region or not. A BMP type region can be a BMP region or a JBP region. PSBs scheduled by DB2 stored procedures, by programs running under WebSphere® Application Server, and by other users of the ODBA interface may be defined with BMPTYPE Y or N.

#### **N**

The program does not execute in a BMP type region. It might execute in an IMS TM MPP, JMP, or IFP region or it might use either the ODBA or DRA interface. This specification should be used for programs running in IMS TM MPP, JMP, and IFP regions, or PSBs scheduled by CICS® programs using DBCTL and other users of the DRA interface. This is the default.

**Y**

The program executes in a BMP type region. It might execute in an IMS BMP region or a JBP region. Any associated transactions are assigned normal and limit priority values of zero.

FP(E) and BMPTYPE(Y) are mutually exclusive.

**DOPT**

Specifies the dynamic option.

**N**

The PSB associated with this program is not located dynamically. The control blocks for the PSB must exist in an ACBLIB or the IMS catalog, otherwise the program is set to a NOTINIT status, and cannot be scheduled. This is the default.

**Y**

The PSB associated with this program is located dynamically. Each time the program that is associated with this PSB is scheduled, the latest copy of the PSB is loaded. When the program terminates, the PSB is deleted from the PSB pool.

Until the PSB is required to process a transaction, the ACB for the PSB does not need to be in the ACBLIB or, if the IMS management of ACBs is enabled, in the IMS catalog. A new version of the PSB can be defined and added to the ACBLIB or the IMS catalog at any time. IMS loads the new version of the ACB the next time the PSB is scheduled.

A DOPT PSB cannot be scheduled if the control blocks for the DBDs that the PSB references are not in the ACBLIB or the IMS catalog.

Keyword combination rules include the following:

- DOPT(Y) and GPSB(Y) are mutually exclusive.
- DOPT(Y) and LANG(JAVA) is a valid combination.
- LANG is invalid with GPSB(N), except if DOPT(Y) and LANG(JAVA).
- LANG(JAVA), DOPT(Y), and GPSB(N) is a valid combination.
- RESIDENT(Y) and DOPT(Y) are mutually exclusive.
- SCHDTYPE(PARALLEL) and DOPT(Y) are mutually exclusive.

**FP**

Specifies the Fast Path option.

**E**

The program is a Fast Path-exclusive program. This implicitly defines a wait-for-input (WFI) program. Either a transaction or a routing code that can be assigned by the user Input Edit/Routing exit routine must be defined for the Fast Path-exclusive program, in order for this program to be usable.

Fast Path must be defined in the IMS system.

**N**

The program is not a Fast Path-exclusive program. This is the default. When FP(N) is specified, any attempt to use Fast Path resources or commands will yield unpredictable results.

Keyword combination rules include the following:

- FP(E) requires that Fast Path be defined.
- LANG(JAVA) and FP(E) are mutually exclusive.
- BMPTYPE(Y) and FP(E) are mutually exclusive.

**GPSB**

Specifies the generated PSB option.

## N

The PSB associated with the program is not generated by IMS. The control blocks for the PSB must exist in the ACBLIB or, if the IMS management of ACBs is enabled, in the IMS catalog, otherwise the program is set to a NOTINIT status, and cannot be scheduled.

## Y

The PSB and application control block (ACB) that are associated with the program are generated by IMS. The scheduling process of all environments generates a PSB that contains an I/O PCB and an alternate modifiable PCB.

You do not need to generate the PSB and ACB or submit DDL to define the PSB. The ACB for the PSB is not loaded from either ACBLIB or, if the IMS management of ACBs is enabled, the IMS catalog. Thus, I/O to retrieve the ACB from either the ACBLIB or the IMS catalog is eliminated.

The generated PSB contains an I/O PCB named IOPCBbbb and a modifiable, alternate PCB named TPPCB1bb. With an alternate modifiable PCB, an application can use the CHNG call to change the output destination and send output to a destination other than the input destination.

Keyword combination rules include the following:

- DOPT(Y) and GPSB(Y) are mutually exclusive.
- DOPT(Y) and LANG(JAVA) is a valid combination.
- GPSB(Y) requires LANG.
- LANG is invalid with GPSB(N), except if DOPT(Y) and LANG(JAVA).
- LANG(JAVA), DOPT(Y), and GPSB(N) is a valid combination.
- RESIDENT(Y) and GPSB(Y) are mutually exclusive.

## LANG

Specifies the language interface of the program for a GPSB, or defines a DOPT(Y) program as using the Java™ language.

In order to define a DOPT program using the Java language, the program must be defined with DOPT(Y) and LANG(JAVA). DOPT PSBs are not loaded at IMS restart, they are loaded every time the program is scheduled. When the program is scheduled for the first time, IMS does not know the language until after the program is scheduled in a region and the PSB is loaded. Unless LANG(JAVA) is defined for the DOPT(Y) program, the program is incorrectly scheduled in a non-Java region.

| LANG parameter | Meaning   |
|----------------|-----------|
| ASSEM          | Assembler |
| COBOL          | COBOL     |
| JAVA           | Java      |
| PASCAL         | Pascal    |
| PLI            | PL/I      |

Keyword combination rules include the following:

- LANG is invalid with GPSB(N), except if DOPT(Y) and LANG(JAVA).
- DOPT(Y) and LANG(JAVA) is a valid combination.
- LANG(JAVA), DOPT(Y), and GPSB(N) is a valid combination.
- LANG(JAVA) and FP(E) are mutually exclusive.

## RESIDENT

Specifies the resident option. The RESIDENT(N) option takes effect right away. The RESIDENT(Y) option takes effect at the next restart, unless an error is encountered such as no PSB in ACBLIB for

the program, or if the program was created as RESIDENT(Y) after the checkpoint from which this IMS is performing emergency restart.

#### **N**

Use N to specify that the PSB associated with the program is not made resident in storage. The PSB is loaded at scheduling time. This is the default. The RESIDENT(N) option takes effect immediately.

#### **Y**

The PSB associated with the program is made resident in storage at IMS cold start or restart. IMS loads the PSB and initializes it. A resident PSB is accessed in local storage, which avoids I/O to retrieve the associated ACB.

Keyword combination rules include the following:

- DOPT(Y) and RESIDENT(Y) are mutually exclusive.
- GPSB(Y) and RESIDENT(Y) are mutually exclusive.

### **SCHDTYPE**

Specifies whether this program can be scheduled into more than one message region or batch message region simultaneously.

#### **PARALLEL**

The program can be scheduled in multiple regions simultaneously. This is the default.

#### **SERIAL**

The program can be scheduled in only one region at a time.

Keyword combination rules include the following:

- DOPT(Y) and SCHDTYPE(PARALLEL) are mutually exclusive.

### **TRANSTAT**

Specifies whether transaction level statistics should be logged. The value specified has meaning only if the program is a JBP or a non-message driven BMP. If Y is specified, transaction level statistics are written to the log in a X'56FA' log record.

#### **N**

Transaction level statistics should not be logged.

#### **Y**

Transaction level statistics should be logged.

The TRANSTAT keyword is optional. If a value is not specified for the TRANSTAT keyword, the system default is used. The system default for the transaction level statistics parameter is set with the TRANSTAT parameter in the DFSDFxxx PROCLIB member. If a value is not specified for the TRANSTAT parameter, the system default is set to N. The TRANSTAT keyword on the **CREATE PGM** command gives the user the ability to override the system default when creating a program resource.

## **Usage notes**

BLDL is performed on the PSB associated with this program (except DOPT or GPSB). If the PSB is not defined in ACBLIB, the program is created anyway and the command results in a completion code of zero, even though it cannot be scheduled. The program status is NOTINIT when a **/DIS PGM** or **QRY PGM** is issued for the program. Online Change must be used to add the PSB to ACBLIB, before the application program can be scheduled.

Resources exist for the life of the IMS unless they are deleted using a **DELETE** command. The resources and descriptors are recoverable across an IMS warm start or emergency restart. Resources and descriptors are lost if IMS is cold started, unless cold start imports definitions that were exported while IMS was up.

The **CREATE PGM** command is similar to local online change (using a **/MODIFY** command) or global online change (**INITIATE OLC**) for application program resources in the MODBLKS data set, except that programs are added dynamically.

A **CREATE PGM** command can be issued only through the Operations Manager API. This command applies to DB/DC, DBCTL and DCCTL systems.

These commands are not valid on the XRF alternate or FDBR region. The **CREATE** command is not valid if online change for MODBLKS is enabled (DFSDFxxx or DFSCGxxx defined with MODBLKS=OLC or MODBLKS not defined).

When a program is created, if the PSB is in the ACBLIB library, the PSB is loaded into the PSB pool at first schedule. If the program is created with RESIDENT(Y), the PSB is made resident at the next IMS restart. If the PSB is not in the ACBLIB library, the program is created anyway, but marked bad because it is unusable. A **QRY PGM** command specified with SHOW(ALL) or SHOW(STATUS) shows the program status as NOTINIT-40-NOPSB, which means there is no PSB in the ACBLIB library for it. You must use online change for the ACBLIB library to add the PSB before the program can be used

## Output fields

The following table shows the **CREATE PGM** output fields. The columns in the table are as follows:

### Short label

Contains the short label generated in the XML output.

### Keyword

Identifies keyword on the command that caused the field to be generated. N/A appears for output fields that are always returned. *error* appears for output fields that are returned only in case of an error.

### Meaning

Provides a brief description of the output field.

*Table 152. Output fields for the CREATE PGM command*

| Short label | Keyword      | Meaning   |
|-------------|--------------|---|
| CC          | N/A          | Completion code.  |
| CCTXT       | <i>error</i> | Completion code text that briefly explains the meaning of the non-zero completion code. |
| MBR         | N/A          | IMSpIplex member that built the output line.  |
| PGM         | PGM          | Program name.   |

## Return, reason, and completion codes

The following table includes the return and reason codes and a brief explanation of the codes. The return or reason code returned for the command might also indicate an error from a CSL request.

*Table 153. Return and reason codes for CREATE PGM*

| Return code | Reason code | Meaning  |
|-------------|-------------|--|
| X'00000000' | X'00000000' | Command completed successfully. The command output contains a line for each resource, accompanied by its completion code. See the completion code table for details. |



Table 153. Return and reason codes for CREATE PGM (continued)

| Return code | Reason code | Meaning  |
|-------------|-------------|--|
| X'00000008' | X'00002009' | Multiple values specified for the same attribute are invalid. For example, you cannot specify both BMPTYPE(Y) and BMPTYPE(N). This reason code is applicable only when you create a program by using the DFSINSX0 user exit. |
| X'00000008' | X'00002048' | Invalid SET attribute.   |
| X'00000008' | X'00002106' | DOPT(Y) mutually exclusive with RESIDENT(Y). Either both keywords were explicitly specified, or one keyword was explicitly specified and the other attribute was gotten from the model.                                      |
| X'00000008' | X'00002107' | DOPT(Y) mutually exclusive with SCHDTYPE(PARALLEL). Either both keywords were explicitly specified, or one keyword was explicitly specified and the other attribute was gotten from the model.                               |
| X'00000008' | X'0000210B' | FP(E) mutually exclusive with BMPTYPE(Y). Either both keywords were explicitly specified, or one keyword was explicitly specified and the other attribute was gotten from the model.   |
| X'00000008' | X'0000210D' | FP(E) mutually exclusive with LANG(JAVA). Either both keywords were explicitly specified, or one keyword was explicitly specified and the other attribute was gotten from the model.   |
| X'00000008' | X'00002113' | GPSB(Y) mutually exclusive with DOPT(Y). Either both keywords were explicitly specified, or one keyword was explicitly specified and the other attribute was gotten from the model.  |
| X'00000008' | X'00002114' | GPSB(N) mutually exclusive with LANG.  |
| X'00000008' | X'00002115' | GPSB(Y) mutually exclusive with RESIDENT(Y). Either both keywords were explicitly specified, or one keyword was explicitly specified and the other attribute was gotten from the model.                                      |
| X'00000008' | X'00002117' | Invalid LIKE descriptor name.  |
| X'00000008' | X'00002118' | Invalid LIKE resource name.  |
| X'00000008' | X'00002131' | GPSB(Y) requires LANG to be specified.   |
| X'00000008' | X'00002132' | DOPT(Y) not supported with LANG except for LANG(JAVA). Either both keywords were explicitly specified, or one keyword was explicitly specified and the other attribute was gotten from the model.                            |
| X'0000000C' | X'00003000' | Command was successful for some resources but failed for others. The command output contains a line for each resource, accompanied by its completion code. See the completion code table for details.                        |
| X'0000000C' | X'00003004' | Command was not successful for any of the resources. The command output contains a line for each resource, accompanied by its completion code. See the completion code table for details.                                    |

Table 153. Return and reason codes for CREATE PGM (continued)

| Return code | Reason code | Meaning  |
|-------------|-------------|--|
| X'00000010' | X'0000400C' | Command is not valid on the XRF alternate.   |
| X'00000010' | X'00004024' | No FP defined, so FP(E) invalid.   |
| X'00000010' | X'00004120' | Online change phase is in progress.  |
| X'00000010' | X'00004204' | Model is quiesced. Cannot quiesce model.   |
| X'00000010' | X'00004300' | Command is not allowed because online change for MODBLKS is enabled (DFSDFxxx or DFSCGxxx defined with MODBLKS=OLC, or MODBLKS not defined).   |
| X'00000014' | X'00005004' | DFSOCMD response buffer could not be obtained.   |
| X'00000014' | X'00005008' | DFSPPOOL storage could not be obtained.  |
| X'00000014' | X'0000500C' | AWE could not be obtained.   |
| X'00000014' | X'00005010' | Unable to obtain latch.  |
| X'00000014' | X'00005114' | Resource or descriptor that is specified as a model is in the process of being imported from the change list in the IMSRSC repository or was not imported successfully from the change list at the end of IMS restart. This resource or descriptor cannot be referenced as a model on a <b>CREATE</b> command until it is successfully imported from the repository. |

Errors unique to the processing of this command are returned as completion codes. The following table includes an explanation of the completion codes.

Table 154. Completion codes for the CREATE PGM command

| Completion code | Completion code text             | Meaning   |
|-----------------|----------------------------------|---|
| 0               |                                  | Command completed successfully for the program.   |
| 11              | RESOURCE ALREADY EXISTS          | Program exists.   |
| 5F              | INVALID CHARACTERS IN NAME       | Name is invalid because it contains an invalid character.   |
| 61              | DFSBCB STORAGE ERROR             | Request to get BCB storage for PDIR control block failed.   |
| 8A              | WILDCARD PARAMETER NOT SUPPORTED | CREATE command does not support wildcard parameters. You must explicitly specify the names of the resources you want to create.   |
| 93              | RESERVED NAME                    | Name is reserved. For example, name starts with DFS (except for DFSSAMxx or DFSIVPxx), or is an IMS reserved name such as BASICEDT or WTOR.   |
| BA              | NOT ALLOWED FOR MRQ PSB          | <b>CREATE</b> command failed for MRQ PSB because an attribute was specified that is not supported for the MRQ PSB: BMPTYPE(N), DOPT(Y), GPSB(Y), FP(E), RESIDENT(Y), SCHDTYPE(SERIAL) |

Table 154. Completion codes for the CREATE PGM command (continued)

| Completion code | Completion code text | Meaning   |
|-----------------|----------------------|---|
| B8              | NO PSB IN ACBLIB     | The DFSINSX0 exit attempted specified that the create should fail if no PSB for the program exists in ACBLIB. |

## Examples

The following are examples of the **CREATE PGM** command:

### Example 1 for CREATE PGM command

TSO SPOC input:

```
CREATE PGM NAME(PGM00001) SET(BMPTYPE(Y))
```

TSO SPOC output:

```
PgmName  MbrName  CC
PGM00001 IMS1     0
```

OM API input:

```
CMD(CREATE PGM NAME(PGM00001) SET(BMPTYPE(Y)))
```

OM API output:

```
<imsout>
<ctl>
<omname>OM10M  </omname>
<omvsn>1.3.0</omvsn>
<xmlvsn>20  </xmlvsn>
<statime>2006.254 22:20:06.531446</statime>
<stotime>2006.254 22:20:06.542510</stotime>
<staseq>BF6453E8EAD76197</staseq>
<stoseq>BF6453E8ED8AE98C</stoseq>
<rqsttkn1>USRT011 10152006</rqsttkn1>
<rc>00000000</rc>
<rsn>00000000</rsn>
</ctl>
<cmd>
<master>IMS1  </master>
<userid>USRT011 </userid>
<verb>CRE </verb>
<kwd>PGM  </kwd>
<input>CREATE PGM NAME(PGM00001) SET(BMPTYPE(Y)) </input>
</cmd>
<cmdsphdr>
<hdr slbl="PGM" llbl="PgmName" scope="LCL" sort="a" key="1" scroll="no"
  len="8" dtype="CHAR" align="left" />
<hdr slbl="MBR" llbl="MbrName" scope="LCL" sort="a" key="2" scroll="no"
  len="8" dtype="CHAR" align="left" />
<hdr slbl="CC" llbl="CC" scope="LCL" sort="n" key="0" scroll="yes"
  len="4" dtype="INT" align="right" skipb="no" />
<hdr slbl="CCTXT" llbl="CCText" scope="LCL" sort="n" key="0"
  scroll="yes" len="*" dtype="CHAR" skipb="yes" align="left" />
</cmdsphdr>
<cmdsphdr>
<rsp>PGM(PGM00001) MBR(IMS1) CC( 0) </rsp>
</cmdsphdr>
</imsout>
```

TSO SPOC input:

```
QRY PGM NAME(PGM00001) SHOW(MODEL,BMPTYPE,DEFNTYPE)
```

TSO SPOC output:

| PgmName  | MbrName | CC | RgnType | BMPTyp | ModelName | ModelType | DefnType |
|----------|---------|----|---------|--------|-----------|-----------|----------|
| PGM00001 | IMS1    | 0  | BMP     | Y      | DFSDSPG1  | DESC      | CREATE   |

**Explanation:** Create a batch program called PGM00001. Attributes not specified on the command are assigned the defaults from the program default descriptor. The **QRY PGM** command shows the model name DFSDSPG1 and model type DESC for the program default descriptor.

### Example 2 for CREATE PGM command

TSO SPOC input:

```
CREATE PGM NAME(DFSSAM02,PLAPJK02,PGM00002,WTOR,PGM*)
```

TSO SPOC output:

| PgmName  | MbrName | CC | CCText                           |
|----------|---------|----|----------------------------------|
| DFSSAM02 | IMS1    | 11 | RESOURCE ALREADY EXISTS          |
| PGM*     | IMS1    | 8A | WILDCARD PARAMETER NOT SUPPORTED |
| PGM00002 | IMS1    | 0  |                                  |
| PLAPJK02 | IMS1    | 11 | RESOURCE ALREADY EXISTS          |
| WTOR     | IMS1    | 93 | RESERVED NAME                    |

OM API input:

```
CMD(CREATE PGM NAME(DFSSAM02,PLAPJK02,PGM00002,WTOR,PGM*))
```

OM API output:

```
<imsout>
<ctl>
<omname>OM10M </omname>
<omvsn>1.3.0</omvsn>
<xmlvsn>20 </xmlvsn>
<statime>2006.254 23:05:22.692697</statime>
<stotime>2006.254 23:05:22.738636</stotime>
<staseq>BF645E0740259287</staseq>
<stoseq>BF645E074B5CC902</stoseq>
<rqsttkn1>USRT011 10160522</rqsttkn1>
<rc>0200000C</rc>
<rsn>00003008</rsn>
<rsnmsg>CSLN054I</rsnmsg>
<rsntxt>None of the clients were successful.</rsntxt>
</ctl>
<cmderr>
<mbr name="IMS1 ">
<typ>IMS </typ>
<styp>DBDC </styp>
<rc>0000000C</rc>
<rsn>00003000</rsn>
<rsntxt>At least one rqst successful</rsntxt>
</mbr>
</cmderr>
<cmd>
<master>IMS1 </master>
<userid>USRT011 </userid>
<verb>CRE </verb>
<kwd>PGM </kwd>
<input>CREATE PGM NAME(DFSSAM02,PLAPJK02,PGM00002,WTOR,PGM*) </input>
</cmd>
<cmdrsphdr>
<hdr slbl="PGM" llbl="PgmName" scope="LCL" sort="a" key="1" scroll="no"
len="8" dtype="CHAR" align="left" />
<hdr slbl="MBR" llbl="MbrName" scope="LCL" sort="a" key="2" scroll="no"
len="8" dtype="CHAR" align="left" />
<hdr slbl="CC" llbl="CC" scope="LCL" sort="n" key="0" scroll="yes"
len="4" dtype="INT" align="right" skipb="no" />
<hdr slbl="CCTXT" llbl="CCText" scope="LCL" sort="n" key="0"
scroll="yes" len="*" dtype="CHAR" skipb="yes" align="left" />
</cmdrsphdr>
<cmdrspdata>
<rsp>PGM(DFSSAM02) MBR(IMS1) CC( 11) CCTXT(RESOURCE ALREADY EXISTS)
</rsp>
<rsp>PGM(PLAPJK02) MBR(IMS1) CC( 11) CCTXT(RESOURCE ALREADY EXISTS)
```

```

</isp>
<isp>PGM(PGM00002) MBR(IMS1) CC(  0) </isp>
<isp>PGM(WTOR   ) MBR(IMS1) CC( 93) CCTXT(RESERVED NAME) </isp>
<isp>PGM(PGM*   ) MBR(IMS1) CC( 8A) CCTXT(WILDCARD PARAMETER NOT
SUPPORTED) </isp>
</cmdispdata>
</imsout>

```

**Explanation:** Several programs fail to be created because of different error conditions. The **CREATE** commands that fail return a nonzero completion code (CC) and completion code text (CCText) that briefly describes the completion code. The **CREATE** command fails for programs DFSSAM02 and PLAPJK02, because they already exist. The **CREATE** command succeeds for program PGM00002. The **CREATE** command fails for program WTOR, because WTOR is a reserved name that cannot be used as a resource name. The **CREATE** command fails for program PGM\*, because an asterisk is an invalid character that cannot be used in a resource name.

### Related concepts

[How to interpret CSL request return and reason codes \(System Programming APIs\)](#)

### Related reference

[“Command keywords and their synonyms” on page 59](#)

All IMS command keywords and their synonyms, as well as keywords supported by the OM API, are listed. The list covers command keywords for the OM command processing clients such as IMS, ODBM, IMSCON, and RM.

## CREATE PGMDESC command

Use the **CREATE PGMDESC** command to create program descriptors. A descriptor is a model that can be used to create descriptors or resources.

A descriptor is created with a value set for every attribute. Attributes not explicitly specified on the **CREATE** command take the default value. Any program resource or descriptor can be created using this descriptor as a model, by specifying the **CREATE** command with `LIKE(DESC(descriptor_name))`.

Subsections:

- [“Environment” on page 265](#)
- [“Syntax” on page 266](#)
- [“Keywords” on page 266](#)
- [“Usage notes” on page 270](#)
- [“Output fields” on page 270](#)
- [“Return, reason, and completion codes” on page 271](#)
- [“Examples” on page 273](#)

### Environment

The following table lists the environments (DB/DC, DBCTL, and DCCTL) in which you can use the command and keywords.

*Table 155. Valid environments for the CREATE PGMDESC command and keywords*

| Command / Keywords    | DB/DC | DBCTL | DCCTL |
|-----------------------|-------|-------|-------|
| <b>CREATE PGMDESC</b> | X     | X     | X     |
| LIKE                  | X     | X     | X     |
| NAME                  | X     | X     | X     |
| SET                   | X     | X     | X     |

## Syntax

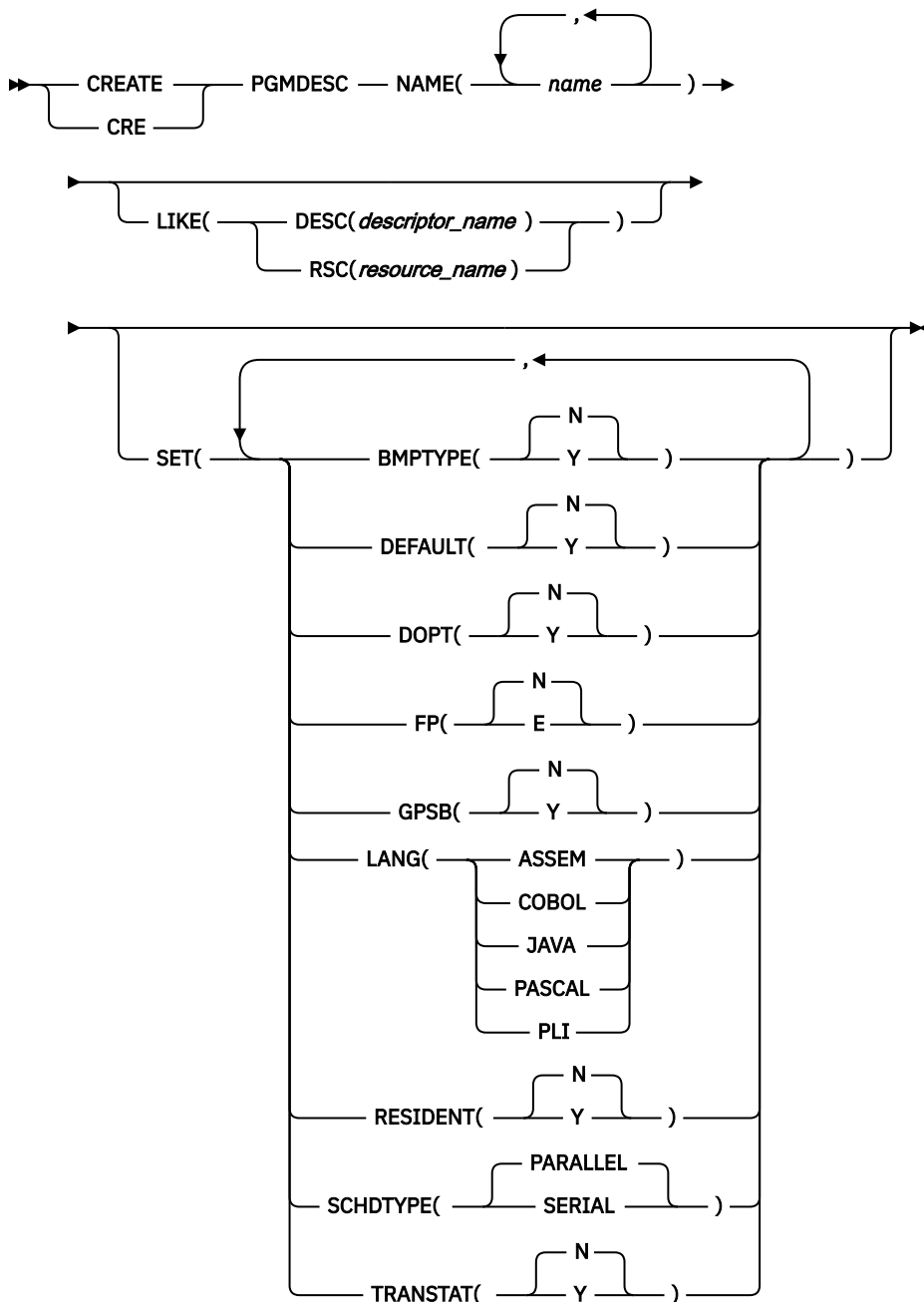

Default values shown in this syntax diagram reflect the default values that are defined in the IMS program descriptor, DFSDSPG1. If you define another descriptor as the default with a **CREATE** or **UPDATE PGMDESC** command, the default values shown in this syntax diagram might not match the value defined in the current default descriptor.

## Keywords

The following keywords are valid for the **CREATE PGMDESC** command:

## LIKE

Specifies that the descriptor is created using an existing resource or descriptor as a model, instead of the default descriptor. The default descriptor is either the IMS descriptor DFSDSPG1, or user-defined. The model type can either be a descriptor (DESC), or a resource (RSC). The descriptor is created with all the same attributes as the model, except for the DEFAULT(Y) value. Attributes set explicitly by the **CREATE** command override the model attributes. DEFAULT(Y) must be specified explicitly to make a descriptor the default descriptor. Later changes to the model are not propagated to resources or descriptors that were created from it.

The **QUERY** commands can be used to display the model name and model type used to create the descriptor or resource. The model name and type returned from the **QUERY** command are provided for informational purposes only. The **EXPORT** command exports a resource definition including the model name and model type to the definition member. The **IMPORT** command imports a resource definition including the model name and model type from the definition member. An **IMPORT** command that creates a resource saves the model name and model type, but does not use the models attributes.

### **DESC(descriptor\_name)**

Specifies the name of the descriptor to use as a model to define this descriptor.

### **RSC(resource\_name)**

Specifies the name of the resource to use as a model to define this descriptor.

## NAME

Specifies the 1-8 character name of the descriptor. Names must be alphanumeric (A through Z, 0 through 9, #, \$, and @). All program names must begin with an alphabetic character (A through Z, #, \$, and @) followed by 0 - 7 alphanumeric characters. Names cannot include a blank, comma, period, hyphen, or equal sign. Names cannot begin with DFS, except for DFSIVPxx and DFSSAMxx. Names cannot be BASICEDT, DBCDM, DBF#FPU0, DBRC, ISCEDT, MSDB, SDB, or WTOR. Each local program name must be unique. If the descriptor is defined with BMPTYPE(N) and FP(N), the program name and associated PSB name must be the same. A program resource and a program descriptor can have the same name.

## SET

Specifies the attributes of the descriptor to be created. If the LIKE keyword is omitted, attributes not specified take the value defined in the default descriptor, which is either IMS descriptor DFSDSPG1 or user-defined. If the LIKE keyword is specified, attributes not specified take the value defined in the model.

### **BMPTYPE()**

BMP type option. Specifies whether the program executes in a BMP type region or not. A BMP type region might be a BMP region or a JBP region.

#### **N**

The program does not execute in a BMP type region. It can execute in an IMS TM MPP, JMP, or IFP region or it can use either the ODBA or DRA interface. This specification should be used for programs running in IMS TM MPP, JMP, and IFP regions, or PSBs scheduled by CICS programs using DBCTL and other users of the DRA interface. This is the default.

#### **Y**

The program executes in a BMP type region. It can execute in an IMS BMP region or a JBP region. Any associated transactions are assigned normal and limit priority values of zero.

### **DEFAULT**

Specifies whether the descriptor is the default.

#### **N**

The descriptor is not the default.

#### **Y**

The descriptor is the default, which resets the existing default descriptor to DEFAULT(N). When a descriptor or resource is created without the LIKE keyword, any attribute not specified on the **CREATE** command takes the value defined in the default descriptor. Only one

descriptor can be defined as the default for a resource type. IMS defines a default program descriptor called DFSDSPG1, where all attributes are defined with the default value. Defining a user-defined descriptor as the default overrides the IMS-defined descriptor. Since only one program descriptor can be the default at one time, only one program name can be specified with DEFAULT(Y).

#### **DOPT**

Specifies the dynamic option.

##### **N**

The PSB associated with this program is not located dynamically. The control blocks for the PSB must exist in an ACBLIB or the IMS catalog, otherwise the program is set to a NOTINIT status, and cannot be scheduled. This is the default.

##### **Y**

The PSB associated with this program is located dynamically. Each time the program that is associated with this PSB is scheduled, the latest copy of the PSB is loaded. When the program terminates, the PSB is deleted from the PSB pool.

Until the PSB is required to process a transaction, the ACB for the PSB does not need to be in the ACBLIB or, if the IMS management of ACBs is enabled, in the IMS catalog. A new version of the PSB can be defined and added to the ACBLIB or the IMS catalog at any time. IMS loads the new version of the ACB the next time the PSB is scheduled.

A DOPT PSB cannot be scheduled if the control blocks for the DBDs that the PSB references are not in the ACBLIB or the IMS catalog.

Keyword combination rules include the following:

- DOPT(Y) and GPSB(Y) are mutually exclusive.
- DOPT(Y) and LANG(JAVA) is a valid combination.
- LANG is invalid with GPSB(N), except if DOPT(Y) and LANG(JAVA).
- LANG(JAVA), DOPT(Y), and GPSB(N) is a valid combination.
- RESIDENT(Y) and DOPT(Y) are mutually exclusive.
- SCHDTYPE(PARALLEL) and DOPT(Y) are mutually exclusive.

#### **FP**

Specifies the Fast Path option.

##### **E**

The program is a Fast Path-exclusive program. This implicitly defines a wait-for-input (WFI) program. Either a transaction or a routing code that can be assigned by the user Input Edit/Routing exit routine must be defined for the Fast Path-exclusive program, in order for this program to be usable.

Fast Path must be defined in the IMS system.

##### **N**

The program is not a Fast Path-exclusive program. This is the default. When FP(N) is specified, any attempt to use Fast Path resources or commands will yield unpredictable results.

Keyword combination rules include the following:

- FP(E) requires that Fast Path be defined.
- LANG(JAVA) and FP(E) are mutually exclusive.
- BMPTYPE(N) and FP(E) are mutually exclusive.

#### **GPSB**

Specifies the generated PSB option.



**N**

The PSB associated with the program is not generated by IMS. The control blocks for the PSB must exist in the ACBLIB or, if the IMS management of ACBs is enabled, in the IMS catalog, otherwise the program is set to a NOTINIT status, and cannot be scheduled.

**Y**

The PSB and application control block (ACB) that are associated with the program are generated by IMS. The scheduling process of all environments generates a PSB that contains an I/O PCB and an alternate modifiable PCB.

You do not need to generate the PSB and ACB or submit DDL to define the PSB. The ACB for the PSB is not loaded from either ACBLIB or, if the IMS management of ACBs is enabled, the IMS catalog. Thus, I/O to retrieve the ACB from either the ACBLIB or the IMS catalog is eliminated.

The generated PSB contains an I/O PCB named IOPCBbbb and a modifiable, alternate PCB named TPPCB1bb. With an alternate modifiable PCB, an application can use the CHNG call to change the output destination and send output to a destination other than the input destination.

Keyword combination rules include the following:

- DOPT(Y) and GPSB(Y) are mutually exclusive.
- DOPT(Y) and LANG(JAVA) is a valid combination.
- GPSB(Y) requires LANG.
- LANG is invalid with GPSB(N), except if DOPT(Y) and LANG(JAVA).
- LANG(JAVA), DOPT(Y), and GPSB(N) is a valid combination.
- RESIDENT(Y) and GPSB(Y) are mutually exclusive.

**LANG**

Specifies the language interface of the program for a GPSB.

| <b>LANG parameter</b> | <b>Meaning</b> |
|-----------------------|----------------|
| ASSEM                 | Assembler      |
| COBOL                 | COBOL          |
| JAVA                  | Java           |
| PASCAL                | Pascal         |
| PLI                   | PL/I           |

Keyword combination rules include the following:

- LANG is invalid with GPSB(N), except if DOPT(Y) and LANG(JAVA).
- DOPT(Y) and LANG(JAVA) is a valid combination.
- LANG(JAVA), DOPT(Y), and GPSB(N) is a valid combination.
- LANG(JAVA) and FP(E) are mutually exclusive.

**RESIDENT**

Specifies the resident option.

**N**

The PSB associated with the program is not made resident in storage. The PSB is loaded at scheduling time. This is the default.

**Y**

The PSB associated with the program is made resident in storage immediately. IMS loads the PSB and initializes it. A resident PSB is accessed in local storage, which avoids I/O to retrieve the

ACB. Resident PSBs are loaded by IMS restart, a **CREATE PGM** or an **UPDATE PGM** command that defines the PSB as resident.

Keyword combination rules include the following:

- DOPT(Y) and RESIDENT(Y) are mutually exclusive.
- GPSB(Y) and RESIDENT(Y) are mutually exclusive.

### **SCHDTYPE**

Specifies whether this program can be scheduled into more than one message region or batch message region simultaneously.

#### **PARALLEL**

The program can be scheduled in multiple regions simultaneously. This is the default.

#### **SERIAL**

The program can only be scheduled in one region at a time.

Keyword combination rules include the following:

- DOPT(Y) and SCHDTYPE(PARALLEL) are mutually exclusive.

### **TRANSTAT**

Specifies whether transaction level statistics should be logged. The value specified has meaning only if the descriptor is a JBP or a non-message driven BMP. If Y is specified, transaction level statistics are written to the log in a X'56FA' log record.

#### **N**

Transaction level statistics should not be logged.

#### **Y**

Transaction level statistics should be logged.

The TRANSTAT keyword is optional. If a value is not specified for the TRANSTAT keyword, the system default is used. The system default for the transaction level statistics parameter is set with the TRANSTAT parameter in the DFSDFxxx PROCLIB member. If a value is not specified for the TRANSTAT parameter, the system default is set to N. The TRANSTAT keyword on the **CREATE PGM** or **CREATE PGMDESC** command gives the user the ability to override the system default when creating a program or program descriptor.

## **Usage notes**

Descriptors exist for the life of the IMS unless they are deleted using a **DELETE** command. The resources and descriptors are recoverable across an IMS warm start or emergency restart. Resources and descriptors are lost if IMS is cold started, unless cold start imports definitions that were exported while IMS was up.

The **CREATE PGMDESC** command can be issued only through the Operations Manager API. This command applies to DB/DC, DBCTL and DCCTL systems.

This command is not valid on the XRF alternate or FDBR region. The **CREATE** command is not valid if online change for MODBLKS is enabled (DFSDFxxx or DFSCGxxx defined with MODBLKS=OLC or MODBLKS not defined).

## **Output fields**

The following table shows the **CREATE PGMDESC** output fields. The columns in the table are as follows:

### **Short label**

Contains the short label generated in the XML output.

**Keyword**

Identifies keyword on the command that caused the field to be generated. N/A appears for output fields that are always returned. *error* appears for output fields that are returned only in case of an error.

**Meaning**

Provides a brief description of the output field.

*Table 156. Output fields for the CREATE PGMDESC command*

| Short label | Keyword      | Meaning  |
|-------------|--------------|--|
| CC          | N/A          | Completion code.   |
| CCTXT       | <i>error</i> | Completion code text that briefly explains the meaning of the nonzero completion code.   |
| DESC        | PGMDESC      | Program descriptor name.   |
| MBR         | N/A          | IMSpIex member that built the output line.   |
| OLDDEF      | PGMDESC      | Old default descriptor name, if this descriptor is made the default by specifying DEFAULT(Y). The old default descriptor is no longer the default. |

**Return, reason, and completion codes**

The following table includes the return and reason codes and a brief explanation of the codes. The return or reason code returned for the command might also indicate an error from a CSL request.

*Table 157. Return and reason codes for CREATE PGMDESC*

| Return code | Reason code | Meaning  |
|-------------|-------------|--|
| X'00000000' | X'00000000' | Command completed successfully. The command output contains a line for each descriptor, accompanied by its completion code. See the completion code table for details.                           |
| X'00000008' | X'00002048' | Invalid SET attribute.   |
| X'00000008' | X'00002106' | DOPT(Y) mutually exclusive with RESIDENT(Y). Either both keywords were explicitly specified, or one keyword was explicitly specified and the other attribute was obtained from the model.        |
| X'00000008' | X'00002107' | DOPT(Y) mutually exclusive with SCHDTYPE(PARALLEL). Either both keywords were explicitly specified, or one keyword was explicitly specified and the other attribute was obtained from the model. |
| X'00000008' | X'0000210B' | FP(E) mutually exclusive with BMPTYPE(Y). Either both keywords were explicitly specified, or one keyword was explicitly specified and the other attribute was obtained from the model.           |
| X'00000008' | X'0000210D' | FP(E) mutually exclusive with LANG(JAVA). Either both keywords were explicitly specified, or one keyword was explicitly specified and the other attribute was obtained from the model.           |

Table 157. Return and reason codes for CREATE PGMDESC (continued)

| Return code | Reason code | Meaning  |
|-------------|-------------|--|
| X'00000008' | X'00002113' | GPSB(Y) mutually exclusive with DOPT(Y). Either both keywords were explicitly specified, or one keyword was explicitly specified and the other attribute was obtained from the model.  |
| X'00000008' | X'00002114' | GPSB(N) mutually exclusive with LANG.  |
| X'00000008' | X'00002115' | GPSB(Y) mutually exclusive with RESIDENT(Y). Either both keywords were explicitly specified, or one keyword was explicitly specified and the other attribute was obtained from the model.  |
| X'00000008' | X'00002117' | Invalid LIKE descriptor name.  |
| X'00000008' | X'00002118' | Invalid LIKE resource name.  |
| X'00000008' | X'00002131' | GPSB(Y) requires LANG to be specified.   |
| X'00000008' | X'00002132' | DOPT(Y) not supported with LANG except for LANG(JAVA). Either both keywords were explicitly specified, or one keyword was explicitly specified and the other attribute was obtained from the model.  |
| X'00000008' | X'00002133' | Multiple name parameters were specified with DEFAULT(Y). Only one descriptor can be the default at one time.   |
| X'0000000C' | X'00003000' | Command was successful for some descriptors but failed for others. The command output contains a line for each descriptor, accompanied by its completion code. See the completion code table for details.  |
| X'0000000C' | X'00003004' | Command was not successful for any of the descriptors. The command output contains a line for each descriptor, accompanied by its completion code. See the completion code table for details.  |
| X'00000010' | X'0000400C' | Command is not valid on the XRF alternate.   |
| X'00000010' | X'00004024' | No FP defined, so FP(E) invalid.   |
| X'00000010' | X'00004120' | Online change phase is in progress.  |
| X'00000010' | X'00004204' | Model is quiesced. Cannot quiesce model.   |
| X'00000010' | X'00004300' | Command is not allowed because online change for MODBLKS is enabled (DFSDFxxx or DFSCGxxx defined with MODBLKS=OLC, or MODBLKS not defined).   |
| X'00000014' | X'00005004' | DFSOCMD response buffer could not be obtained.   |
| X'00000014' | X'00005008' | DFSPool storage could not be obtained.   |
| X'00000014' | X'0000500C' | AWE could not be obtained.   |
| X'00000014' | X'00005010' | Unable to obtain latch.  |
| X'00000014' | X'00005114' | Resource or descriptor that is specified as a model is in the process of being imported from the change list in the IMSRSC repository or was not imported successfully from the change list at the end of IMS restart. This resource or descriptor cannot be referenced as a model on a <b>CREATE</b> command until it is successfully imported from the repository. |

Errors unique to the processing of this command are returned as completion codes. The following table includes an explanation of the completion codes.

*Table 158. Completion codes for the CREATE PGMDESC command*

| Completion code | Completion code text             | Meaning  |
|-----------------|----------------------------------|--|
| 0               |                                  | Command completed successfully for program descriptor.   |
| 11              | RESOURCE ALREADY EXISTS          | Program descriptor already exists.   |
| 5F              | INVALID CHARACTERS IN NAME       | Name is invalid because it contains an invalid character.  |
| 61              | DFSBCB STORAGE ERROR             | Request to get BCB storage for PDIR control block failed.  |
| 8A              | WILDCARD PARAMETER NOT SUPPORTED | The <b>CREATE</b> command does not support wildcard parameters. You must explicitly specify the names of the descriptors you want to create. |
| 93              | RESERVED NAME                    | Name is reserved. For example, name starts with DFS (except for DFSSAMxx or DFSIVPxx), or is an IMS reserved name such as BASICEDT or WTOR.  |

### Examples

The following are examples of the **CREATE PGMDESC** command:

#### **Example 1 for CREATE PGMDESC command**

TSO SPOC input:

```
CREATE PGMDESC NAME(FPEDESC) SET(DOPT(Y) FP(E) BMPTYPE(N),SCHDTYPE(SERIAL))
```

TSO SPOC output:

```
DescName  MbrName  CC
FPEDESC   IMS1      0
```

OM API input:

```
CMD(CREATE PGMDESC NAME(FPEDESC) SET(DOPT(Y) FP(E) BMPTYPE(N),SCHDTYPE(SERIAL)))
```

OM API output:

```
<imsout>
<ctl>
<omname>OM10M  </omname>
<omvsn>1.3.0</omvsn>
<xmlvsn>20  </xmlvsn>
<statime>2006.254 22:51:06.632728</statime>
<stotime>2006.254 22:51:06.633257</stotime>
<staseq>BF645AD6D921890E</staseq>
<stoseq>BF645AD6D9429A8E</stoseq>
<rqsttkn1>USRT011 10155106</rqsttkn1>
<rc>00000000</rc>
<rsn>00000000</rsn>
</ctl>
<cmd>
<master>IMS1  </master>
<userid>USRT011 </userid>
```

```

<verb>CREATE </verb>
<kwd>PGMDESC </kwd>
<input>CREATE PGMDESC NAME(FPEDESC) SET(DOPT(Y) FP(E)
BMPTYPE(N),SCHDTYPE(SERIAL)) </input>
</cmd>
<cmdrsphdr>
<hdr slbl="DESC" llbl="DescName" scope="LCL" sort="a" key="1"
scroll="no" len="8" dtype="CHAR" align="left" />
<hdr slbl="MBR" llbl="MbrName" scope="LCL" sort="a" key="2" scroll="no"
len="8" dtype="CHAR" align="left" />
<hdr slbl="CC" llbl="CC" scope="LCL" sort="n" key="0" scroll="yes"
len="4" dtype="INT" align="right" skipb="no" />
<hdr slbl="CCTXT" llbl="CCText" scope="LCL" sort="n" key="0"
scroll="yes" len="*" dtype="CHAR" skipb="yes" align="left" />
</cmdrsphdr>
<cmdrspdata>
<rsp>DESC(FPEDESC ) MBR(IMS1) CC( 0) </rsp>
</cmdrspdata>
</imsout>

```

**Explanation:** Creates a descriptor with attributes appropriate for a Fast Path exclusive program. Subsequent Fast Path exclusive programs can be created more easily by using this descriptor.

### Related concepts

[How to interpret CSL request return and reason codes \(System Programming APIs\)](#)

### Related reference

[“Command keywords and their synonyms” on page 59](#)

All IMS command keywords and their synonyms, as well as keywords supported by the OM API, are listed. The list covers command keywords for the OM command processing clients such as IMS, ODBM, IMSCON, and RM.

## CREATE RTC command

Use the **CREATE RTC** command to create a Fast Path routing code that can be used by the Fast Path Input Edit/Routing Exit Routine (DBFHAGU0) to route a transaction to a different application program within the same load balancing group for processing.

Subsections:

- [“Environment” on page 274](#)
- [“Syntax” on page 275](#)
- [“Keywords” on page 275](#)
- [“Usage notes” on page 276](#)
- [“Output fields” on page 276](#)
- [“Return, reason, and completion codes” on page 277](#)
- [“Examples” on page 278](#)

### Environment

The following table lists the environments (DB/DC, DBCTL, and DCCTL) in which you can use the command and keywords.

*Table 159. Valid environments for the CREATE RTC command and keywords*

| Command / Keywords | DB/DC | DBCTL | DCCTL |
|--------------------|-------|-------|-------|
| <b>CREATE RTC</b>  | X     |       | X     |
| LIKE               | X     |       | X     |
| NAME               | X     |       | X     |
| SET                | X     |       | X     |

## Syntax

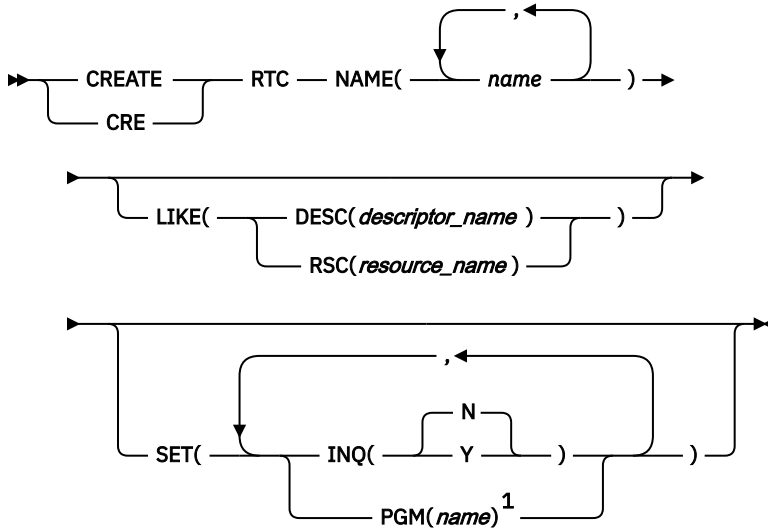

### Notes:

<sup>1</sup> The PGM() keyword is required if the default descriptor or other descriptor from which the resource is being created does not already have a program defined.

Default values shown in this syntax diagram reflect the default values that are defined in the IMS routing code descriptor, DBFDSRT1. If you define another descriptor as the default with a **CREATE** or **UPDATE RTCDDESC** command, the default values shown in this syntax diagram might not match the value defined in the current default descriptor.

## Keywords

The following keywords are valid for the **CREATE RTC** command:

### LIKE

Specifies that the resource is created using an existing resource or descriptor as a model, instead of the default descriptor. The default descriptor is either the IMS descriptor DBFDSRT1, or user-defined. The model type can either be a descriptor (DESC), or a resource (RSC). The new resource is created with all the same attributes as the model, except for the DEFAULT(Y) value. Attributes set explicitly by the **CREATE** command override the model attributes. Later changes to the model are not propagated to resources or descriptors that were created from it.

**QUERY** commands can be used to display the model name and model type used to create the resource. The model name and type returned from the **QUERY** command are provided for informational purposes only. The **EXPORT** command exports a resource definition, including the model name and model type, to the definition member. The **IMPORT** command imports a resource definition, including the model name and model type, from the definition member. An **IMPORT** command that creates a resource saves the model name and model type, but does not use the models attributes.

When LIKE is used on a **CREATE** command, the models current attributes are used to set the attributes of the newly created resource.

#### **DESC(descriptor\_name)**

Specifies the name of the descriptor to use as a model to define this resource.

#### **RSC(resource\_name)**

Specifies the name of the resource to use as a model to define this resource.

## NAME

Specifies the one- to eight-character alphanumeric routing code. Names must be alphanumeric (A through Z, 0 through 9, #, \$, and @). Names cannot include a blank, comma, period, hyphen, or equal sign. Names cannot begin with DFS, except for DFSIVPxx and DFSSAMxx. Names cannot be BASICEDT, DBCDM, DBFDSRT1, DBRC, ISCEDT, MSDB, SDB, or WTOR. Routing codes can be duplicates of either transaction names or logical terminal names, but each must be unique within the set of routing codes. A set of routing codes is the group of all routing codes associated with the same program. A routing code resource and a routing code descriptor can have the same name.

## SET

Specifies the attributes of the routing code to be created. If the LIKE keyword is omitted, attributes not specified take the value defined in the default descriptor, which is either IMS descriptor DBFDSRT1 or user-defined. If the LIKE keyword is specified, attributes not specified take the value defined in the model.

## INQ

### N

This is not an inquiry transaction. This is the default.

### Y

This is an inquiry transaction. Any message associated with the routing code is an inquiry transaction. This should be specified only for transactions that do not cause a change to a database. Programs are prohibited from issuing Insert, Delete, or Replace calls to a database when processing a transaction defined as INQ(Y).

## PGM

Specifies the name of the program associated with the routing code. For a **CREATE RTC** command, the program must exist and be defined with a BMPTYPE(N). The PGM() keyword is required if the default descriptor or other descriptor from which the resource is being created does not already have a program defined.

## Usage notes

Resources exist for the life of the IMS unless they are deleted using a **DELETE** command. The resources are recoverable across an IMS warm start or emergency restart. Resources are lost if IMS is cold started, unless cold start imports definitions that were exported while IMS was up.

The **CREATE RTC** command is similar to local online change (using a **/MODIFY** command) or global online change (**INITIATE OLC**) for routing code resources in the MODBLKS data set, except that routing codes are added dynamically.

The **CREATE RTC** command can be issued only through the Operations Manager API. Fast Path must be installed on the system. This command applies to DB/DC and DCCTL systems.

This command is not valid on the XRF alternate or FDBR region. The **CREATE** command is not valid if online change for MODBLKS is enabled (DFSDFxxx or DFSCGxxx defined with MODBLKS=OLC or MODBLKS not defined).

## Output fields

The following table shows the **CREATE RTC** output fields. The columns in the table are as follows:

### Short label

Contains the short label generated in the XML output.

### Keyword

Identifies keyword on the command that caused the field to be generated. N/A appears for output fields that are always returned. *error* appears for output fields that are returned only in case of an error.

### Meaning

Provides a brief description of the output field.



Table 160. Output fields for the CREATE RTC command

| Short label | Keyword      | Meaning   |
|-------------|--------------|---|
| CC          | N/A          | Completion code.  |
| CCTXT       | <i>error</i> | Completion code text that briefly explains the meaning of the non-zero completion code. |
| MBR         | N/A          | IMSpIex member that built the output line.  |
| RTC         | RTC          | Routing code name.  |

## Return, reason, and completion codes

The following table includes the return and reason codes and a brief explanation of the codes. The return or reason code returned for the command might also indicate an error from a CSL request.

Table 161. Return and reason codes for CREATE RTC

| Return code | Reason code | Meaning   |
|-------------|-------------|---|
| X'00000000' | X'00000000' | Command completed successfully. The command output contains a line for each resource, accompanied by its completion code. See the completion code table for details.                                  |
| X'00000008' | X'00002048' | Invalid SET attribute.  |
| X'00000008' | X'00002117' | Invalid LIKE descriptor name.   |
| X'00000008' | X'00002118' | Invalid LIKE resource name.   |
| X'00000008' | X'00002120' | No PGM() defined.   |
| X'00000008' | X'00002123' | Invalid PGM name. PGM was specified explicitly, or gotten from the model. If the IMS-defined descriptor DBFDSRT1 was used, the command failed because DBFDSRT1 defines no program name.               |
| X'00000008' | X'00002133' | Multiple name parameters were specified with DEFAULT(Y). Only one descriptor can be the default at one time.  |
| X'0000000C' | X'00003000' | Command was successful for some resources but failed for others. The command output contains a line for each resource, accompanied by its completion code. See the completion code table for details. |
| X'0000000C' | X'00003004' | Command was not successful for any of the resources. The command output contains a line for each resource, accompanied by its completion code. See the completion code table for details.             |
| X'00000010' | X'0000400C' | Command is not valid on the XRF alternate.  |
| X'00000010' | X'00004024' | No Fast Path defined.   |
| X'00000010' | X'00004120' | Online change phase is in progress.   |
| X'00000010' | X'00004204' | Model is quiesced. Cannot quiesce model.  |
| X'00000010' | X'00004300' | Command is not allowed because online change for MODBLKS is enabled (DFSDFxxx or DFSCGxxx defined with MODBLKS=OLC, or MODBLKS not defined).  |
| X'00000010' | X'0000431C' | Program is quiesced. Cannot quiesce program.  |

Table 161. Return and reason codes for CREATE RTC (continued)

| Return code | Reason code | Meaning  |
|-------------|-------------|--|
| X'00000014' | X'00005004' | DFSOCMD response buffer could not be obtained.   |
| X'00000014' | X'00005008' | DFSPOOL storage could not be obtained.   |
| X'00000014' | X'0000500C' | AWE could not be obtained.   |
| X'00000014' | X'00005010' | Unable to obtain latch.  |
| X'00000014' | X'00005114' | Resource or descriptor that is specified as a model is in the process of being imported from the change list in the IMSRSC repository or was not imported successfully from the change list at the end of IMS restart. This resource or descriptor cannot be referenced as a model on a <b>CREATE</b> command until it is successfully imported from the repository. |

Errors unique to the processing of this command are returned as completion codes. The following table includes an explanation of the completion codes.

Table 162. Completion codes for the CREATE RTC command

| Completion code | Completion code text             | Meaning   |
|-----------------|----------------------------------|---|
| 0               |                                  | Command completed successfully for routing code.  |
| 11              | RESOURCE ALREADY EXISTS          | Routing code already exists.  |
| 17              | ANOTHER CMD IN PROGRESS          | Another command (such as <b>DELETE PGM</b> or <b>UPDATE PGM</b> ) is in progress for the program referenced by this routing code.           |
| 5F              | INVALID CHARACTERS IN NAME       | Name is invalid because it contains an invalid character.   |
| 61              | DFSBCB STORAGE ERROR             | Request to get BCB storage for RCTE control block failed.   |
| 7A              | RTC/FP=N PGM CONFLICT            | Routing code to be created conflicts with program defined as non-Fast Path FP(N).   |
| 8A              | WILDCARD PARAMETER NOT SUPPORTED | The <b>CREATE</b> command does not support wildcard parameters. You must explicitly specify the names of the resources you want to create.  |
| 90              | INTERNAL ERROR                   | Internal error.   |
| 93              | RESERVED NAME                    | Name is reserved. For example, name starts with DFS (except for DFSSAMxx or DFSIVPxx), or is an IMS reserved name such as BASICEDT or WTOR. |

### Examples

The following are examples of the **CREATE RTC** command:

#### Example 1 for CREATE RTC command

TSO SPOC input:

```
CRE RTC (NAME(RTC00001)) LIKE(RSC(TXCDRN14))
```

TSO SPOC output:

| RtcName  | MbrName | CC |
|----------|---------|----|
| RTC00001 | IMS1    | 0  |

OM API input:

```
CMD(CRE RTC (NAME(RTC00001)) LIKE(RSC(TXCDRN14)))
```

OM API output:

```
<imsout>
<ctl>
<omname>OM10M </omname>
<omvsrn>1.3.0</omvsrn>
<xmlvsrn>20 </xmlvsrn>
<statime>2006.254 23:36:59.043090</statime>
<stotime>2006.254 23:36:59.043761</stotime>
<staseq>BF646517C0512E05</staseq>
<stoseq>BF646517C07B1705</stoseq>
<rqsttkn1>USRT011 10163658</rqsttkn1>
<rc>00000000</rc>
<rsn>00000000</rsn>
</ctl>
<cmd>
<master>IMS1 </master>
<userid>USRT011 </userid>
<verb>CRE </verb>
<kwd>RTC </kwd>
<input>CRE RTC (NAME(RTC00001)) LIKE(RSC(TXCDRN14)) </input>
</cmd>
<cmdrsphdr>
<hdr slbl="RTC" llbl="RtcName" scope="LCL" sort="a" key="1" scroll="no"
len="8" dtype="CHAR" align="left" />
<hdr slbl="MBR" llbl="MbrName" scope="LCL" sort="a" key="2" scroll="no"
len="8" dtype="CHAR" align="left" />
<hdr slbl="CC" llbl="CC" scope="LCL" sort="n" key="0" scroll="yes"
len="4" dtype="INT" align="right" />
</cmdrsphdr>
<cmdrspdata>
<rsp>RTC(RTC00001) MBR(IMS1) CC( 0) </rsp>
</cmdrspdata>
</imsout>
```

TSO SPOC input:

```
QRY RTC (NAME(RTC0*)) SHOW(MODEL,INQ,PGM,DEFNTYPE)
```

TSO SPOC output:

| Rtcode   | MbrName | CC | PgmName  | Inq | ModelName | ModelType | DefnType |
|----------|---------|----|----------|-----|-----------|-----------|----------|
| RTC00001 | IMS1    | 0  | DDLTRN14 | N   | TXCDRN14  | RSC       | CREATE   |

**Explanation:** A **CREATE RTC** command is issued to create routing code RTC00001 like an already existing routing code called TXCDRN14. The **QRY RTC** command shows the model name TXCDRN14, specified by the LIKE keyword, and model type RSC, for routing code TXCDRN14.

### Related concepts

[How to interpret CSL request return and reason codes \(System Programming APIs\)](#)

### Related reference

[“Command keywords and their synonyms” on page 59](#)

All IMS command keywords and their synonyms, as well as keywords supported by the OM API, are listed. The list covers command keywords for the OM command processing clients such as IMS, ODBM, IMSCON, and RM.

## CREATE RTCDESC command

Use the **CREATE RTCDESC** command to create Fast Path routing code descriptors.

A descriptor is a model that can be used to create routing code descriptors or resources. A descriptor is created with a value set for every attribute. Attributes not explicitly specified on the **CREATE** command take the default value. Any routing code resource or descriptor can be created using this descriptor as a model, by specifying the **CREATE** command with `LIKE(DESC(descriptor_name))`.

Subsections:

- [“Environment” on page 280](#)
- [“Syntax” on page 280](#)
- [“Keywords” on page 281](#)
- [“Usage notes” on page 282](#)
- [“Output fields” on page 282](#)
- [“Return, reason, and completion codes” on page 283](#)
- [“Examples” on page 285](#)

### Environment

The following table lists the environments (DB/DC, DBCTL, and DCCTL) in which you can use the command and keywords.

Table 163. Valid environments for the CREATE RTCDESC command and keywords

| Command / Keywords    | DB/DC | DBCTL | DCCTL |
|-----------------------|-------|-------|-------|
| <b>CREATE RTCDESC</b> | X     |       | X     |
| LIKE                  | X     |       | X     |
| NAME                  | X     |       | X     |
| SET                   | X     |       | X     |

### Syntax

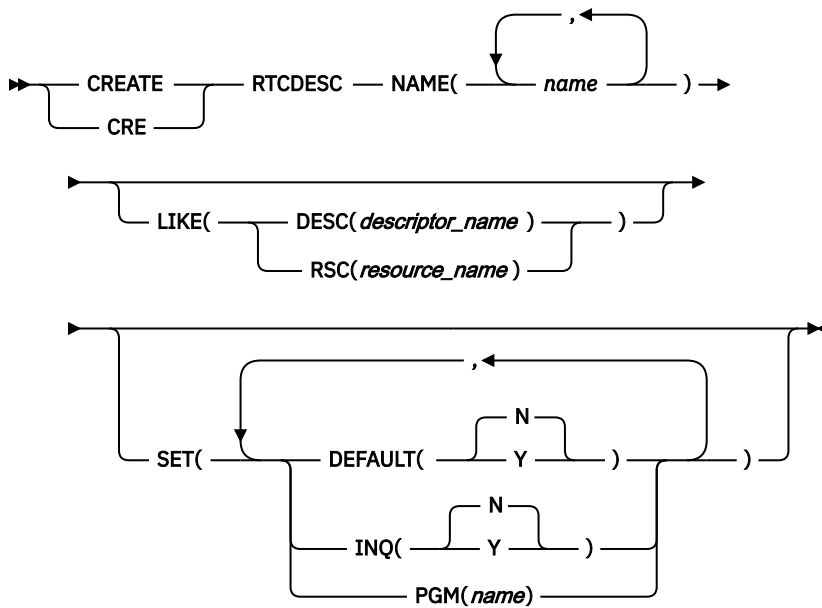

Default values shown in this syntax diagram reflect the default values that are defined in the IMS routing code descriptor, DBFDSRT1. If you define another descriptor as the default with a **CREATE** or **UPDATE RTCDESC** command, the default values shown in this syntax diagram might not match the value defined in the current default descriptor.

## Keywords

The following keywords are valid for the **CREATE RTCDESC** command:

### LIKE

Specifies that the descriptor is created using an existing resource or descriptor as a model, instead of the default descriptor. The default descriptor is either the IMS descriptor DBFDSRT1, or user-defined. The model type can either be a descriptor (DESC), or a resource (RSC). The descriptor is created with all the same attributes as the model, except for the DEFAULT(Y) value. Attributes set explicitly by the **CREATE** command override the model attributes. DEFAULT(Y) must be specified explicitly to make a descriptor the default descriptor. Later changes to the model are not propagated to resources or descriptors that were created from it.

**QUERY** commands can be used to display the model name and model type used to create the descriptor or resource. The model name and type returned from the **QUERY** command are provided for informational purposes only. The **EXPORT** command exports a resource definition including the model name and model type to the definition member. The **IMPORT** command imports a resource definition including the model name and model type from the definition member. An **IMPORT** command that creates a resource saves the model name and model type, but does not use the model's attributes.

When LIKE is used on a **CREATE** command, the model's current attributes are used to set the attributes of the newly-created resource or descriptor, except for the default attribute.

### DESC(descriptor\_name)

Specifies the name of the descriptor to use as a model to define this descriptor.

### RSC(resource\_name)

Specifies the name of the resource to use as a model to define this descriptor.

### NAME

Specifies the one- to eight-character alphanumeric routing code descriptor. Names must be alphanumeric (A through Z, 0 through 9, #, \$, and @). Names cannot include a blank, comma, period, hyphen, or equal sign. Names cannot begin with DFS, except for DFSIVPxx and DFSSAMxx. Names

cannot be BASICEDT, DBCDM, DBFDSRT1, DBRC, ISCEDT, MSDB, SDB, or WTOR. Routing codes can be duplicates of either transaction names or logical terminal names, but each must be unique within the set of routing codes. A set of routing codes is the group of all routing codes associated with the same program. A routing code resource and a routing code descriptor can have the same name.

## SET

Specifies the attributes of the routing code descriptor to be created. If the LIKE keyword is omitted, attributes not specified take the value defined in the default descriptor, which is either IMS descriptor DBFDSRT1 or user-defined. If the LIKE keyword is specified, attributes not specified take the value defined in the model.

## DEFAULT

Specifies whether the descriptor is the default.

### N

The descriptor is not the default.

### Y

The descriptor is the default, which resets the existing default descriptor to DEFAULT(N). When a descriptor or resource is created without the LIKE keyword, any attribute not specified on the CREATE command takes the value defined in the default descriptor. Only one descriptor can be defined as the default for a resource type. IMS defines a default routing code descriptor called DBFDSRT1, where all attributes are defined with the default value. Defining a user-defined descriptor as the default overrides the IMS-defined descriptor. Since only one routing code descriptor can be the default at one time, only one routing code parameter may be specified with DEFAULT(Y).

## INQ

### N

This is not an inquiry transaction. This is the default.

### Y

This is an inquiry transaction. Any message associated with the routing code descriptor is an inquiry transaction. This should be specified only for transactions that do not cause a change to a database. Programs are prohibited from issuing Insert, Delete, or Replace calls to a database when processing a transaction defined as INQ(Y).

## PGM

Specifies the name of the program associated with the routing code descriptor.

## Usage notes

Descriptors exist for the life of the IMS unless they are deleted using a **DELETE** command. The resources and descriptors are recoverable across an IMS warm start or emergency restart. Descriptors are lost if IMS is cold started, unless cold start imports definitions that were exported while IMS was up.

The **CREATE RTCDDESC** command can only be issued through the Operations Manager API. Fast Path must be installed on the system. This command applies to DB/DC and DCCTL systems.

This command is not valid on the XRF alternate or FDBR region. The **CREATE** command is not valid if online change for MODBLKS is enabled (DFSDfxxx or DFSCGxxx defined with MODBLKS=OLC or MODBLKS not defined).

## Output fields

The following table shows the **CREATE RTCDDESC** output fields. The columns in the table are as follows:

### Short label

Contains the short label generated in the XML output.

**Keyword**

Identifies keyword on the command that caused the field to be generated. N/A appears for output fields that are always returned. *error* appears for output fields that are returned only in case of an error.

**Meaning**

Provides a brief description of the output field.

*Table 164. Output fields for the CREATE RTCDESC command*

| Short label | Keyword      | Meaning  |
|-------------|--------------|--|
| CC          | N/A          | Completion code.   |
| CCTXT       | <i>error</i> | Completion code text that briefly explains the meaning of the non-zero completion code.  |
| DESC        | RTCDESC      | Routing code descriptor name.  |
| MBR         | N/A          | IMSpIex member that built the output line.   |
| OLDDEF      | RTCDESC      | Old default descriptor name, if this descriptor is made the default by specifying DEFAULT(Y). The old default descriptor is no longer the default. |

**Return, reason, and completion codes**

The following table includes the return and reason codes and a brief explanation of the codes. The return or reason code returned for the command might also indicate an error from a CSL request.

*Table 165. Return and reason codes for CREATE RTCDESC*

| Return code | Reason code | Meaning   |
|-------------|-------------|---|
| X'00000000' | X'00000000' | Command completed successfully. The command output contains a line for each descriptor, accompanied by its completion code. See the completion code table for details.                                    |
| X'00000008' | X'00002048' | Invalid SET attribute.  |
| X'00000008' | X'00002117' | Invalid LIKE descriptor name.   |
| X'00000008' | X'00002118' | Invalid LIKE resource name.   |
| X'00000008' | X'00002123' | Invalid PGM name. PGM was specified explicitly, or gotten from the model. If the IMS-defined descriptor DBFDSRT1 was used, the command failed because DBFDSRT1 defines no program name.                   |
| X'00000008' | X'00002137' | Multiple name parameters specified with DEFAULT(Y) is invalid. Only one descriptor can be the default at one time.  |
| X'0000000C' | X'00003000' | Command was successful for some descriptors but failed for others. The command output contains a line for each descriptor, accompanied by its completion code. See the completion code table for details. |
| X'0000000C' | X'00003004' | Command was not successful for any of the descriptors. The command output contains a line for each descriptor, accompanied by its completion code. See the completion code table for details.             |
| X'00000010' | X'0000400C' | Command is not valid on the XRF alternate.  |

Table 165. Return and reason codes for CREATE RTCDESC (continued)

| Return code | Reason code | Meaning  |
|-------------|-------------|--|
| X'00000010' | X'00004024' | No Fast Path defined.  |
| X'00000010' | X'00004120' | Online change phase is in progress.  |
| X'00000010' | X'00004204' | Model is quiesced. Cannot quiesce model.   |
| X'00000010' | X'00004300' | Command is not allowed because online change for MODBLKS is enabled (DFSDFxxx or DFSCGxxx defined with MODBLKS=OLC, or MODBLKS not defined).   |
| X'00000014' | X'00005004' | DFSOCMD response buffer could not be obtained.   |
| X'00000014' | X'00005008' | DFSPool storage could not be obtained.   |
| X'00000014' | X'0000500C' | AWE could not be obtained.   |
| X'00000014' | X'00005010' | Unable to obtain latch.  |
| X'00000014' | X'00005114' | Resource or descriptor that is specified as a model is in the process of being imported from the change list in the IMSRSC repository or was not imported successfully from the change list at the end of IMS restart. This resource or descriptor cannot be referenced as a model on a <b>CREATE</b> command until it is successfully imported from the repository. |

Errors unique to the processing of this command are returned as completion codes. The following table includes an explanation of the completion codes.

Table 166. Completion codes for the CREATE RTCDESC command

| Completion code | Completion code text             | Meaning   |
|-----------------|----------------------------------|---|
| 0               |                                  | Command completed successfully for routing code descriptor.   |
| 11              | RESOURCE ALREADY EXISTS          | Routing code descriptor already exists.   |
| 17              | ANOTHER CMD IN PROGRESS          | Another command (such as DELETE PGM or UPDATE PGM) is in progress for the program referenced by this routing code descriptor.   |
| 5F              | INVALID CHARACTERS IN NAME       | Name is invalid because it contains an invalid character.   |
| 61              | DFSBCB STORAGE ERROR             | Request to get BCB storage for RCTE control block failed.   |
| 7A              | RTC/FP=N PGM CONFLICT            | Routing code to be created conflicts with program defined as non-Fast Path FP(N).   |
| 8A              | WILDCARD PARAMETER NOT SUPPORTED | CREATE command does not support wildcard parameters. You must explicitly specify the names of the resources you want to create. |
| 90              | INTERNAL ERROR                   | Internal error  |



Table 166. Completion codes for the CREATE RTCDESC command (continued)

| Completion code | Completion code text | Meaning   |
|-----------------|----------------------|---|
| 93              | RESERVED NAME        | Name is reserved. For example, name starts with DFS (except for DFSSAMxx or DFSIVPxx), or is an IMS reserved name such as BASICEDT or WTOR. |

### Examples

The following are examples of the **CREATE RTCDESC** command:

#### Example 1 for CREATE RTCDESC command

TSO SPOC input:

```
CRE RTCDESC NAME(DRCTR02,DRCTR03) LIKE(RSC(FPTRN01)) SET(PGM(FPPSB03))
```

TSO SPOC output:

```
DescName MbrName CC
DRCTR02 IMS1 0
DRCTR03 IMS1 0
```

**Explanation:** A **CREATE RTCDESC** command is issued to create two routing code descriptors at IMS1 in an IMSplex. Routing code descriptors DRCTR02 and DRCTR03 are defined using the existing routing code resource called FPTRN01. Routing code FPTRN01 is defined with INQ(Y). Descriptors DRCTR02 and DRCTR03 are defined using routing code FPTRN01 as a model for the INQ(Y) attribute, but overriding the program name by explicitly specifying PGM(FPPSB03) on the command.

### Related concepts

[How to interpret CSL request return and reason codes \(System Programming APIs\)](#)

### Related reference

[“Command keywords and their synonyms” on page 59](#)

All IMS command keywords and their synonyms, as well as keywords supported by the OM API, are listed. The list covers command keywords for the OM command processing clients such as IMS, ODBM, IMSCON, and RM.

## CREATE TRAN command

Use the **CREATE TRAN** command to create a transaction code that causes the application program associated with the program resource defined by PGM() to be scheduled for execution in an IMS message processing region.

The transaction provides IMS with information that influences the application program scheduling algorithm. The program resource defined by PGM() keyword must exist for the **CREATE TRAN** command to complete successfully.

Subsections:

- [“Environment” on page 286](#)
- [“Syntax” on page 286](#)
- [“Keywords” on page 288](#)
- [“Usage notes” on page 300](#)
- [“Output fields” on page 301](#)
- [“Return, reason, and completion codes” on page 301](#)

- “Examples” on page 306

## Environment

The following table lists the environments (DB/BC, DBCTL, and DCCTL) from which the command keywords can be issued.

Table 167. Valid environments for the CREATE TRAN command and keywords

| Command / Keywords | DB/DC | DBCTL | DCCTL |
|--------------------|-------|-------|-------|
| <b>CREATE TRAN</b> | X     |       | X     |
| LIKE               | X     |       | X     |
| NAME               | X     |       | X     |
| SET                | X     |       | X     |

## Syntax

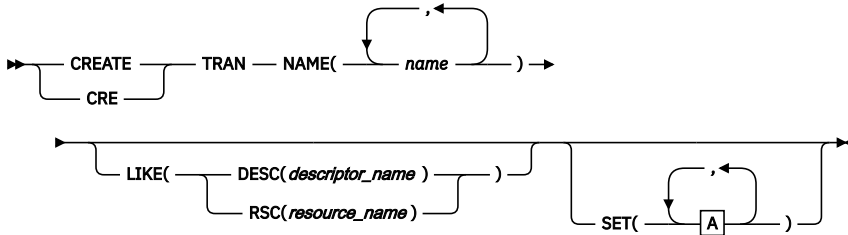

A

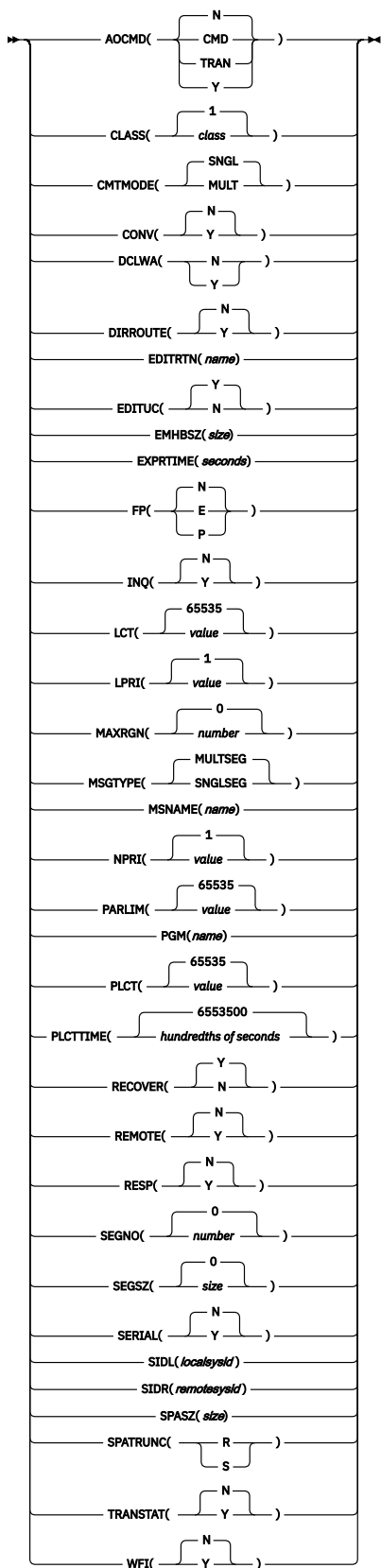

Default values shown in this syntax diagram reflect the default values that are defined in the IMS transaction descriptor, DFSDSTR1. If you define another descriptor as the default with a **CREATE** or **UPDATE TRANDESC** command, the default values shown in this syntax diagram might not match the value defined in the current default descriptor.

## Keywords

The following keywords are valid for the **CREATE TRAN** command:

### LIKE

Specifies that the resource is created using an existing resource or descriptor as a model, instead of the default descriptor. The default descriptor is either the IMS descriptor DFSDSTR1, or user-defined. The model type can either be a descriptor (DESC), or a resource (RSC). The new resource is created with all the same attributes as the model. Attributes set explicitly by the **CREATE** command override the model attributes. Later changes to the model are not propagated to resources or descriptors that were created from it.

The **QUERY** commands can be used to display the model name and model type used to create the resource. The model name and type returned from the **QUERY** command are provided for informational purposes only. The **EXPORT** command exports a resource definition, including the model name and model type, to the definition member. The **IMPORT** command imports a resource definition, including the model name and model type, from the definition member. An **IMPORT** command that creates a resource saves the model name and model type, but does not use the models attributes.

#### **DESC(descriptor\_name)**

Specifies the name of the descriptor to use as a model to define this resource.

#### **RSC(resource\_name)**

Specifies the name of the resource to use as a model to define this resource.

### NAME

Specifies the 1-8 character name of the transaction. Names must be alphanumeric (A through Z, 0 through 9, #, \$, and @). Names cannot include a blank, comma, period, hyphen, or equal sign. Names cannot begin with DFS, except for DFSCONE, DFSIVPxx, and DFSSAMxx. Names cannot be BASICEDT, DBCDM, DBRC, ISCEDT, MSDB, SDB, or WTOR. A transaction resource and a transaction descriptor can have the same name. A transaction cannot have the same name as an lterm.

### SET

Specifies the attributes of the transaction to be created. If the LIKE keyword is omitted, attributes not specified take the value defined in the default descriptor, which is either the IMS descriptor DFSDSTR1, or user-defined. If the LIKE keyword is specified, attributes not specified take the value defined in the model. A transaction must have the same characteristics in all systems where it is defined when it is shared. These characteristics include:

- Nonconversational/conversational
- SPA size if conversational
- Single-/multi-segment messages
- Noninquiry/inquiry
- Recoverable/nonrecoverable
- Response mode/non-response mode
- Fast Path exclusive/Fast Path potential/non-Fast Path

### AOCMD

Specifies the AOI option that indicates whether the transaction can issue the type-1 AOI CMD call or the type-2 AOI ICMD call. If AOCMD is defined as CMD, TRAN, or Y, and the AOI1 execute parameter is defined as AOI1=N, no authorization checking is done, and the transaction is permitted to issue CMD and ICMD calls.

### N

Indicates that the transaction is not permitted to issue type-1 AOI CMD calls. The transaction is permitted to issue type-2 AOI ICMD calls.

**CMD**

Indicates that the transaction is permitted to issue type-1 AOI CMD calls and type-2 AOI ICMD calls. If the AOI1 execute parameter is defined as C, R, or A, authorization checking is based on which transactions can issue a particular command. In this case, the commands (or the first three characters of the commands) need to be defined to RACF or an equivalent product as a user. The type-1 AOI transactions must be defined as profiles under the TIMS class, and for each transaction, the commands it can issue must be specified. Defining AOCMD(CMD) requires you to create fewer user IDs than you need to create for the AOCMD(TRAN) definition. However, defining AOCMD(CMD) requires you to create or modify a larger number of resource profiles.

**TRAN**

Indicates that the transaction is permitted to issue type-1 AOI CMD calls and type-2 AOI ICMD calls. If the AOI1 execute parameter is defined as C, R, or A, the transaction code is used for authorization. The first authorization check results in the accessor environment element (ACEE) being built. This environment is kept for use by future authorization checks. The type-1 AOI transaction needs to be defined to RACF or an equivalent product as a user. The transactions will then be specified on RACF PERMIT statements for each command they are allowed to issue from a type-1 AOI transaction. Specifying AOI transactions as users to RACF might conflict with the name of a user already defined to RACF. If this occurs, then either the transaction name or the existing user name needs to be changed.

**Y**

Indicates that the transaction is permitted to issue type-1 AOI CMD calls and type-2 AOI ICMD calls. If the AOI1 execute parameter is defined as C, R, or A, the user ID or the program name is used for authorization. For some environments, if a Get Unique call has not yet occurred, the program name is used for authorization.

**CLASS**

Specifies the transaction class, which is an attribute used to select a transaction for scheduling. A transaction can be scheduled if there is a message processing region available for that class. The value can be a number from 1 to 999. The default is 1. This value must not exceed the value given (by specification or default) on the MAXCLAS= keyword of the IMSCTRL macro.

Define CPI-C transactions with a different message class from that used for non-CPI-C transactions. IMS handles all CPI-C transactions as priority zero within the transaction class.

**CMTMODE**

Specifies when database updates and non-express output messages are committed. This operand affects emergency restart.

**MULT**

Database updates and non-express output messages are committed only when the application program terminates normally, when the processing limit count has been reached, or, in the case of a pseudo-WFI dependent region, when there are no more messages on the queue. For example, if five transactions are processed during a single schedule of a program, all five are committed only when the fifth one is completed and the program terminates. Until a transaction has been committed, locks for updated database records are not released and non-express output messages are not queued for output. If an application ends abnormally before committing its messages, emergency restart requeues all the messages that were processed within the commit scope and makes them available for reprocessing.

If the transaction results in the application calling an external subsystem, such as DB2, the Commit Verify exit provided by the external subsystem can determine whether CMTMODE(MULT) is supported. See documentation under the Commit Verify exit routine in *IMS Version 15.3 Exit Routines*.

**SNGL**

Database updates and non-express output messages are committed when the application program completes processing each transaction. IMS invokes commit processing either when the application program requests the next message (issues a GU to the IO-PCB), or when the application program terminates. If an application ends abnormally before committing its message,

emergency restart requeues the message that was in process before the abend and makes it available for reprocessing. This is the default.

**Note:** The TRANSACT macro MODE keyword uses a default of MULT. The **CREATE TRAN** command CMTMODE keyword uses a default of SNGL.

Keyword combination rules include the following:

- CMTMODE(MULT) and CONV(Y) are mutually exclusive.
- CMTMODE(MULT) and WFI(Y) are mutually exclusive.

## **CONV**

Specifies the conversation option.

### **N**

The transaction is not conversational. This is the default.

### **Y**

The transaction is conversational. The transaction message is destined for a conversational program. A conversational program processes transactions made up of several steps. A conversational program receives a message from a terminal, replies to the terminal, but saves the data from the transaction in a scratchpad area (SPA). When the person at the terminal enters more data, the program has the data it saved from the last message in the SPA, so it can continue processing the request without the person at the terminal having to enter the data again.

Keyword combination rules include the following:

- CMTMODE(MULT) and CONV(Y) are mutually exclusive.
- FP(E) and CONV(Y) are mutually exclusive.
- CONV(Y) requires SPASZ and SPATRUNC.
- RECOVER(N) and CONV(Y) are mutually exclusive.
- SPASZ and CONV(N) are mutually exclusive.
- SPATRUNC and CONV(N) are mutually exclusive.

## **DCLWA**

Specifies the log write-ahead option. If not specified and the default descriptor is the IMS-defined descriptor DFSDSTR1, the value is defined to be the DFSDFxxx PROCLIB member DCLWA parameter at IMS cold start. Changing the DFSDFxxx DCLWA value across a restart has no effect on the default descriptor DCLWA value. If DCLWA is not defined in the DFSDFxxx PROCLIB member, the default is DCLWA=Y.

### **N**

IMS should not perform log write-ahead. Specify N if input message integrity and the consistency of output messages with associated database updates is not required. DCLWA does not apply to response mode or Fast Path input processing, and is ignored during IMS execution.

### **Y**

IMS should perform log write-ahead for recoverable, nonresponse input messages and transaction output messages. This ensures the following:

- A nonresponse input transaction is made recoverable across IMS failures before IMS acknowledges receipt of the input.
- Database changes are made recoverable before IMS sends associated output reply messages.
- Information in the log buffers is written to the IMS log, before the associated input acknowledgment or output reply is sent to the terminal.

Define DCLWA(Y) for all VTAM terminal types.

## **DIRROUTE**

Specifies the MSC directed routing option.

**N**

The application program processing a transaction is not informed of the system which originated the transaction. The name of the originating LTERM is placed in the I/O PCB. This is the default.

**Y**

The application program processing a transaction is informed of the system which originated the transaction, if MSC directed routing is used in a multiple IMS system configuration. An MSNAME corresponding to a logical path back to the originating system is placed in the I/O PCB.

**EDITRTN**

Specifies the 1- to 8-character name of your transaction input edit routine that edits messages before the program receives the message. This name must be alphanumeric (A through Z, 0 through 9, #, \$, and @). It must begin with an alphabetic character (A through Z, #, \$, @). It cannot include a blank, comma, period, hyphen, or equal. It cannot include the wildcard characters \* or %.

The specified edit routine can either be an edit routine defined during the system definition process with the EDIT= parameter on the TRANSACT macro or it can be a new routine. If the routine is a new routine, the routine must reside in one of the RESLIB concatenated data sets. A maximum of 255 input edit routines are supported.

If the edit routine specified on the command is new to IMS, IMS attempts to load the routine from RESLIB. If the load fails, the command is rejected. If the edit routine specified is already defined to IMS, a decision is made whether to load a new copy of the routine or to use the existing copy. If the routine was generated into the system, but there are no transactions referencing the routine, IMS first attempts to load a new copy of the module from RESLIB. If the load is successful, the dynamic copy of the edit routine is used. The generated copy cannot be used again unless IMS is cold started. If the load of the dynamic routine fails, the generated copy is used. If the edit routine was generated into the system and other transactions reference it, the generated copy of the module is used.

EDITRTN is used for a Fast Path potential transaction when the transaction is routed to IMS.

For input from LU 6.2 devices, the user edit exit routine DFSLUEE0 is called instead of the transaction input edit routine specified in EDITRTN.

Keyword combination rules include the following:

- FP(E) and EDITRTN are mutually exclusive.

**EDITUC**

Specifies the edit to uppercase option.

**N**

The input data is not translated to uppercase. It can consist of upper and lowercase characters as entered from the terminal.

**Y**

The input data is to be translated to uppercase before it is presented to the processing program. If FP(E) or FP(P), the transaction is to be translated to uppercase before being presented to the edit/routing exit routine. This is the default.

Specifying EDITUC(Y) for VTAM terminals prevents the transmission of embedded device control characters.

**EMHBSZ**

Specifies the EMH buffer size required to run the Fast Path transaction. This overrides the EMHL execution parameter. If EMHBSZ is not specified, the EMHL execution parameter value is used. The value can be a number from 0 to 30 720.

Keyword combination rules include the following:

- EMHBSZ>0 requires Fast Path to be defined.
- FP(N) and EMHBSZ>0 are mutually exclusive.

## EXPRTIME

Specifies the elapsed time in seconds that IMS can use to cancel the input transaction. After a transaction is submitted to IMS, the transaction could be delayed for processing because of a stopped transaction or a potential system slow down. In that case, the user or client application could time out before the transaction is processed. When IMS eventually schedules and processes the transaction, the response message is no longer wanted. With the elapsed time specified for the transaction, IMS can flag the input transaction as expired so that the system does not waste CPU cycles to process the unwanted transaction.

The value can be a number, in seconds, which can range from 0 to 65535. The default is 0, which means that no expiration time is set for this transaction. The transaction expiration attribute is supported by all of the IMS TM interfaces.

**Restriction:** The transaction expiration checking is not performed at the GU time for Fast Path transactions, IMS conversational transactions, program-to-program switch transactions, and APPC synchronous transactions.

## FP

Specifies the Fast Path option.

### E

The transaction is processed exclusively as Fast Path. A Fast Path routing code by the same name is created. The program must be defined as Fast Path exclusive.

### N

The transaction is not a candidate for Fast Path processing. The program identified by PGM() must be defined as not Fast Path. This is the default.

### P

The transaction is a potential candidate for Fast Path processing. Fast Path-potential transactions must be able to run under two programs: a Fast Path exclusive program a non-Fast Path program. This **CREATE TRAN** command defines the non-Fast Path program with PGM(). A Fast Path exclusive program should be defined to which this transaction can be routed. Fast Path-potential transactions must be processed by a user edit/routing exit to determine whether the transaction is actually to be processed by IMS Fast Path. If it is to be processed by IMS Fast Path, the edit/routing exit routine associates the transaction with a routing code. This routing code identifies which Fast Path program is to process the transaction.

The program defined by PGM() must not be defined as Fast Path exclusive.

Keyword combination rules include the following:

- EDITRTN and FP(E) are mutually exclusive.
- FP(P) and FP(E) require Fast Path to be defined.
- CONV(Y) and FP(E) are mutually exclusive.
- MSGTYPE(MULTSEG) and FP(E) are mutually exclusive.
- MSGTYPE(MULTSEG) and FP(P) are mutually exclusive.
- MSNAME and FP(E) are mutually exclusive.
- MSNAME and FP(P) are mutually exclusive.
- RECOVER(N) and FP(E) are mutually exclusive.
- RECOVER(N) and FP(P) are mutually exclusive.
- RESP(N) and FP(E) are mutually exclusive.
- RESP(N) and FP(P) are mutually exclusive.
- SIDL and FP(E) are mutually exclusive.
- SIDL and FP(P) are mutually exclusive.
- SIDR and FP(E) are mutually exclusive.
- SIDR and FP(P) are mutually exclusive.



**INQ**

Specifies the inquiry option.

**N**

This is not an inquiry transaction. This is the default.

**Y**

This is an inquiry transaction. If INQ(Y) is specified, you can also specify whether this transaction should be recovered during an IMS emergency or normal restart using the RECOVER() parameter.

This option should be specified only for those transactions that, when entered, do not cause a change in any database. Programs are prohibited from issuing ISRT, DLET, or REPL calls to a database when scheduled to process a transaction defined as INQ(Y).

An application program cannot do an SQL INSERT, DELETE, or UPDATE when the IMS transaction is defined with INQ(Y).

Keyword combination rules include the following:

- RECOVER(N) and INQ(N) are mutually exclusive.

**LCT**

Specifies the limit count. This is the number that, when compared to the number of input transactions queued and waiting to be processed, determines whether the normal or limit priority value is assigned to this transaction. The value can be a number from 1 to 65535. The default is 65535.

The limit count value is ignored for a transaction processed by a BMP.

The limit count value is ignored in a shared-queues environment.

The limit count value does not apply to FP exclusive transactions and is ignored.

**LPRI**

Specifies the limit priority. This is the scheduling priority to which this transaction is raised when the number of input transactions enqueued and waiting to be processed is equal to or greater than the limit count value. The scheduling priority is an attribute used to select a transaction for scheduling. A transaction of higher priority is scheduled before a lower priority one, if they are defined with the same class. The value can be a number from 0 through 14. The default is 1.

When the limit priority is used and the scheduling priority is raised to the limit priority, the priority is not reduced to the normal priority until all messages enqueued for this transaction name are processed. If you do not want the limit priority for this transaction, define equal values for the normal priority and limit priority, and a limit count of 65535.

When a transaction is processed exclusively by a batch message program (BMP), define the limit priority as 0. If the program specified by PGM() is defined with a program type of batch, the current priority is forced to be 0. However, a batch message processing region (BMP) can process transactions with current scheduling priorities other than 0.

This priority also controls the priority of messages created by this transaction and sent to a destination in a remote system. See also the discussion on MSC priorities under the NPRI definition.

The limit priority value is ignored for a transaction processed by a BMP.

Scheduling ignores the limit priority value for batch programs. If the transaction refers to a batch program and a non-zero LPRI value is specified, it is set to 0.

The limit priority value is ignored in a shared queues environment.

**MAXRGN**

Specifies the maximum region count. This count value limits the number of message processing program (MPP) regions that can be concurrently scheduled to process a transaction. When the number of MPP regions is not limited, one transaction might monopolize all available regions. The value can be a number between 0 and the value specified on the MAXPST= control region parameter.

MAXRGN(0) means that no limit is imposed. If you define the program with a scheduling type of SERIAL, omit the MAXRGN parameter or define it as 0.

Keyword combination rules include the following:

- PARLIM(65535) and MAXRGN>0 are mutually exclusive.
- SERIAL(Y) and MAXRGN>0 are mutually exclusive.

## **MSGTYPE**

Specifies the message type (single segment or multiple segment). It specifies the time at which an incoming message is considered complete and available to be routed to an application program for subsequent processing.

If MSC-directed routing is used in a multiple IMS system configuration, IMS does not ensure that both the message and the transaction destined to process that message are either single segment or multiple segments.

### **MULTSEG**

The incoming message can be more than one segment in length. It is not eligible for scheduling to an application program until an end-of-message indication is received, or a complete message is created by MFS. This is the default.

### **SNGLSEG**

The incoming message is one segment in length. It becomes eligible for scheduling when the terminal operator indicates end-of-segment.

Keyword combination rules include the following:

- FP(E) and MSGTYPE(MULTSEG) are mutually exclusive.
- FP(P) and MSGTYPE(MULTSEG) are mutually exclusive.

## **MSNAME**

Specifies the one- to eight-character name of the logical link path in a multiple IMS system configuration (MSC). A logical link path is a path between any two IMS systems. The IMS systems are identified by the remote system ID and the local system ID associated with the logical link path. The remote system ID identifies the system in which messages using this path are to be processed. The local system ID identifies this system. If this transaction is exported, the local and remote system IDs are exported, not the msname. For a **CREATE TRAN** command adding a remote transaction, the MSNAME must already be defined.

Keyword combination rules include the following:

- FP(E) and MSNAME are mutually exclusive.
- FP(P) and MSNAME are mutually exclusive.
- SIDL and MSNAME are mutually exclusive.
- SIDR and MSNAME are mutually exclusive.

## **NPRI**

Specifies the normal scheduling priority. The scheduling priority is an attribute used to select a transaction for scheduling. A transaction of higher priority is scheduled before a lower priority one, if they are defined with the same class. When a transaction resource is created, the current priority (CPRI), or the scheduling priority, is initialized to the normal priority (NPRI). The normal priority is also assigned to a transaction as the current priority when the number of input transactions enqueued and waiting to be processed is less than the limit count value. The value can be a number from 0 through 14. The default is 1.

This priority also controls the priority of messages created by this transaction and sent to a destination in a remote system.

When a transaction is processed exclusively by a batch message program (BMP), code the normal priority as 0.

When a transaction is processed exclusively by a batch message program (BMP), define the limit priority as 0. If the program specified by PGM() is defined with a program type of batch, the current priority is forced to be 0. However, a batch message processing region (BMP) can process transactions with current scheduling priorities other than 0.

For remote transactions, the priority used to send the transaction to the processing system, which is termed the MSC link message priority. The three MSC link message priority groups are:

- Low
- Medium
- High

The low priority group consists of primary requests in the input terminal system. This group is assigned remote transaction priorities from 0 to 6. The medium group consists of secondary requests, responses, primary requests in an intermediate system, and primary requests in the input terminal system. This group is assigned a remote transaction priority of 7. The high group consists of primary requests in the input terminal system. Messages in this group are assigned remote transaction priorities from 8 to 14. Within each group, messages have a priority based on the current priority value of the transaction or remote transaction in the input terminal system for primary requests, and on the latest processing system for secondary requests and responses.

In an MSC configuration, the transaction priority determines the priority used to send messages inserted by this transaction across an MSC link. If the transaction inserts multiple messages to the same destination (for example, pages to a printer) and these messages must be sent in the order inserted, the normal and limit priority values should be the same. If the normal and limit priority values are not identical, messages inserted at a higher priority than previously inserted messages could arrive at their destination first. (This restriction does not apply to multiple segments of the same message.)

The normal priority value is ignored for a transaction processed by a BMP.

Scheduling ignores the normal priority value for batch programs. If the transaction refers to a batch program and a non-zero NPRI value is specified, it is set to 0.

## **PARLIM**

Specifies the parallel processing limit count. This is the maximum number of messages that can currently be queued, but not yet processed, by each active message region currently scheduled for this transaction. This is the threshold value to be used when the associated program is defined with a scheduling type of parallel. An additional region is scheduled whenever the current transaction enqueue count exceeds the PARLIM value multiplied by the number of regions currently scheduled for this transaction.

The value can be a number from 0 to 32767 or 65535. PARLIM(0) indicates that any input message can cause a new region to be scheduled because the scheduling condition is always being met (the number of messages are greater than zero). If you specify PARLIM(0), you should specify a MAXRGN value to limit the number of regions that can be scheduled to process a particular transaction. PARLIM(65535) means that parallel processing is disabled and IMS allows the transaction to be scheduled in only one region at a time. PARLIM(65535) is the default.

The value specified for PARLIM applies to message processing programs (MPPs) only; it is not supported for batch message processing programs (BMPs).

If you define the transaction as serial or the program with a scheduling type as SERIAL, define PARLIM(65535).

In a shared-queues environment (when the scheduling type is PARALLEL), any PARLIM value other than 65535 causes a new region to be scheduled whenever the successful consecutive GU count exceeds the PARLIM value multiplied by the number of regions currently scheduled for this transaction. For shared-queues environments, the successful consecutive GU count is used instead of the queue count. New regions continue to be scheduled up to the maximum number of regions specified on MAXRGN.

The PARLIM keyword is not applicable to FPE transactions and should be allowed to default to 65535. A PARLIM value can be specified for FPE transactions, but it is ignored by scheduling. Specifying a PARLIM value that is not the default will result in a BAL status shown for an FPE transaction on commands such as **/DISPLAY TRAN** or **QUERY TRAN**. The PARLIM and BAL status can be ignored for FPE transactions.

Keyword combination rules include the following:

- MAXRGN>0 and PARLIM(65535) are mutually exclusive.
- SERIAL(Y) and PARLIM value 0 - 32767 are mutually exclusive.

### **PGM**

Specifies the name of the program associated with the transaction.

For a **CREATE TRAN** command specified with REMOTE(N), the program must exist. PGM() is required, except for remote transactions defined with REMOTE(Y).

### **PLCT**

Specifies the processing limit count. This is maximum number of messages sent to the application program by IMS for processing without reloading the application program. The value must be a number from 0 through 65535. PLCT(0) means the maximum number of messages sent to the application is one and the application program is reloaded before receiving a subsequent message. PLCT(65535) means that no limit is to be placed upon the number of messages processed at a single program load. Values 1 through 65535 are eligible for quick reschedule processing. The default is 65535.

The value is used to determine how many messages an application program is allowed to process in a single scheduling cycle. When the application program requests, and receives, the number of messages indicated, any subsequent requests result in one of two actions.

- IMS indicates “no more messages exist” if any of the following conditions is true:
  - The region is not an MPP.
  - The currently scheduled mode is not CMTMODE(SNGL).
  - Equal or higher priority transactions are enqueued for the region.

IMS might have other messages enqueued for the application program. It is the responsibility of the application program to terminate when it receives an indicator that no more messages are available. Termination of the application program makes the region it occupied available for rescheduling. This feature makes it possible for IMS to enable scheduling of higher priority transactions that entered the system while the previous transactions were in process. In addition, if any equal-priority transactions are enqueued, they become eligible for scheduling on a first-in, first-out (FIFO) basis.

- The region goes through quick reschedule and returns the next message to the application if all of the following conditions are true:
  - The region is an MPP.
  - The transaction is CMTMODE(SNGL).
  - No equal or higher transactions are enqueued.
  - Messages are still enqueued for the application program.

### **PLCTTIME**

Specifies the processing limit count time. This is the amount of time (in hundredths of seconds) allowable to process a single transaction (or message). The number specifies the maximum CPU time allowed for each message to be processed in the message processing region.

Batch Message Programs (BMPs) are not affected by this setting.

The value can be a number, in hundredths of seconds, that can range from 1 to 6553500. A value of 6553500 means no time limit is placed on the application program. The default is 6553500.

If Fast Path is used, this keyword specifies, for a given transaction name, the amount of time (in hundredths of seconds) the program is allowed to process a single transaction message. The time represents real time that elapses during transaction processing (not accumulated task time). Real time is used because the input terminal is in response mode and cannot enter another transaction until the response is sent. In this case PLCT() is ignored.

The value controls application program looping. You are not required to optimize the value for program-transaction execution time. However, the time value assigned should not be less than the expected per-transaction execution time. If the scheduled application program exceeds the product of PLCTTIME() and PLCT(), the application program ends abnormally. If an IMS STIMER value of 2 is specified on the DFSMPR procedure, the region does not abend until completion of the DL/I call.

The application program must not use STIMER timer services. IMS uses STIMER timer services to time the execution of transactions. If an application program issues an MVS STIMER macro, it cancels the STIMER timer services set by IMS. Use the STIMERM macro instead for application program timer requests.

## **RECOVER**

Specifies the recovery option.

**Y**

The transaction is recovered during IMS emergency or normal restart. This is the default.

**N**

The transaction is not recovered.

Keyword combination rules include the following:

- CONV(Y) and RECOVER(N) are mutually exclusive.
- FP(E) and RECOVER(N) are mutually exclusive.
- FP(P) and RECOVER(N) are mutually exclusive.
- INQ(N) and RECOVER(N) are mutually exclusive.

## **REMOTE**

Specifies the remote option.

**N**

The transaction is not remote. The transaction is local and runs on the local system. This is the default.

**Y**

The transaction is remote. The transaction runs on a remote system.

Keyword combination rules include the following:

- REMOTE(Y) requires MSNAME or SIDR and SIDL.

## **RESP**

Specifies the response-mode option.

**N**

The transaction is not response mode. For terminals specifying or accepting a default of OPTIONS=TRANRESP, input should not stop after this transaction is entered. This is the default.

**Y**

The transaction is response mode. The terminal from which the transaction is entered is held and prevents further input until a response is received. For terminals specifying or accepting a default of OPTIONS=TRANRESP, no additional messages are to be allowed after this transaction is entered until this transaction sends a response message back to the terminal. Response mode can be forced or negated by individual terminal definition. RESP(Y) is ignored during online processing for all terminals that do not operate in response mode.

Keyword combination rules include the following:

- FP(E) and RESP(N) are mutually exclusive.

- FP(P) and RESP(N) are mutually exclusive.

## SEGNO

Specifies the segment number. This is the maximum number of application program output segments that are allowed into the message queues per Get Unique (GU) call from the application program. The value can be a number from 0 through 65535. The default is 0. If SEGNO(0) is defined, the number of segments is not checked by the online system at execution time.

## SEGSZ

Specifies the segment size. This is the maximum number of bytes allowed in any one output segment. The value can be a number from 0 through 65535. The default is 0. If SEGSZ(0) is defined, the segment size is not checked by the online system at execution time.

The maximum output message segment to an LU 6.2 device is 32767. If a transaction is expected to send output to an LU 6.2 device, the SEGSIZE parameter should be no greater than 32767. However, this is not enforced during processing of the command, because IMS cannot determine the device type for the message destination until output time.

## SERIAL

Specifies the serial option.

### N

Messages for the transaction are not processed serially. Message processing can be processed in parallel. Messages are placed on the suspend queue after a U3303 pseudoabend. Scheduling continues until repeated failures result in the transaction being stopped with a USTOP. This is the default.

### Y

Messages for the transaction are processed serially. U3303 pseudoabends do not cause the message to be placed on the suspend queue but rather on the front of the transaction message queue, and the transaction is stopped with a USTOP. The USTOP of the transaction is removed when the transaction or the class is started with a **/START** or **UPD TRAN** command.

Keyword combination rules include the following:

- MAXRGN>0 and SERIAL(Y) are mutually exclusive.
- PARLIM value 0 - 32767 and SERIAL(Y) are mutually exclusive.

## SIDL

Specifies the system identification (SYSID) of the local system in a multiple-IMS system (MSC) configuration. The local system is the originating system to which responses are returned. The value can be a number from 1 to 2036, if MSC is enabled, or 0, if MSC is not enabled. The local SYSID can be defined in any or all of the MSNAMEs or transactions.

For a CREATE TRAN command creating a remote transaction by specifying SET(MSNAME()) or SET(SIDR(),SIDL()), where SIDR is different from SIDL, the MSNAME that represents that SIDL/SIDR pair must already be defined.

For a local transaction where SIDL is not specified, SIDL is defined with a value of the lowest system ID when MSC is enabled on this system, or SIDL is defined with a value of 0 when MSC is not enabled on this system.

The local system ID (SIDL) and the remote system ID (SIDR) are the same for local transactions. When creating a local transaction, if the SIDL and SIDR values are not defined as local to this IMS, the lowest system ID is used for the SIDL and SIDR values.

The SIDL parameter is independent of the link type (CTC, MTM, TCP/IP, VTAM) specified on the TYPE= keyword of the MSPLINK macro statement.

Keyword combination rules include the following:

- FP(E) and SIDL are mutually exclusive, unless SIDL and SIDR are specified as a pair and are equal to the local system ID of this IMS.

- FP(P) and SIDL are mutually exclusive.
- MSNAME and SIDL are mutually exclusive.
- SIDL value must be defined to this IMS.

## **SIDR**

Specifies the system identification (SYSID) of the remote system in a multiple-IMS system (MSC) configuration. The remote system is the system on which the application program executes. The value can be a number from 1 to 2036 if MSC is enabled, or 0 if MSC is not enabled. The remote SYSID specified must also be defined for an MSNAME.

For a CREATE TRAN command creating a remote transaction by specifying SET(MSNAME()) or SET(SIDR(),SIDL()), where SIDR is different from SIDL, the MSNAME that represents that SIDL/SIDR pair must already be defined.

Local transactions must have the SIDR value set equal to the SIDL value. Both values must be set to the same local SYSID.

The SIDR parameter is independent of the link type (CTC, MTM, TCP/IP, VTAM) specified on the TYPE= keyword of the MSPLINK macro statement.

Keyword combination rules include the following:

- FP(E) and SIDR are mutually exclusive, unless SIDL and SIDR are specified as a pair and are equal to the local system ID of this IMS.
- FP(P) and SIDR are mutually exclusive.
- MSNAME and SIDR are mutually exclusive.
- SIDR value must be defined to this IMS.

## **SPASZ**

Specifies the scratchpad area (SPA) size, in bytes, for a conversational transaction. The value can be a number from 16 and 32767.

Keyword combination rules include the following:

- CONV(N) and SPASZ are mutually exclusive.
- FP(E) and SPASZ are mutually exclusive.

## **SPATRUNC**

Specifies the scratchpad area (SPA) truncation option of a conversational transaction. This keyword defines whether the SPA data should be truncated or preserved across a program switch to a transaction that is defined with a smaller SPA. If this keyword is not specified for a conversational transaction, the value is obtained from the model (RSC, DESC, or default descriptor). If the SPATRUNC value is not specified or set in the model, the SPATRUNC value is set based on the value specified for the TRUNC parameter in the DFSDCxxx PROCLIB member at IMS cold start. Changing the DFSDCxxx TRUNC value across a restart has no effect on the default descriptor SPATRUNC value.

When a conversation initially starts, and when a program is switched, the SPATRUNC option is checked and set or reset as specified. When the option is set, it remains set for the life of the conversation, or until a program switch occurs to a transaction that specifies the option is to be reset.

When a program switch occurs, the truncated data option for the new transaction is first checked, and that specification is set for the conversation and is used for the SPA inserted into the output message. If the option is not specified for the new transaction, the option currently in effect for the conversation is used.

## **S**

IMS preserves all of the data in the SPA, even when a program switch is made to a transaction that is defined with a smaller SPA. The transaction with the smaller SPA does not see the truncated data, but when the transaction switches to a transaction with a larger SPA, the truncated data is used.

## R

The truncated data is not preserved.

Keyword combination rules include the following:

- CONV(N) and SPATRUNC are mutually exclusive.
- FP(E) and SPATRUNC are mutually exclusive.

## TRANSTAT

Specifies whether transaction level statistics are to be logged for message driven programs. If Y is specified, transaction level statistics are written to the log in a X'56FA' log record.

## N

Transaction level statistics are not logged.

## Y

Transaction level statistics are logged.

The TRANSTAT keyword is optional. If not specified and the default descriptor is the IMS-defined descriptor DFSDSTR1, the value is defined to be the DFSDFxxx PROCLIB member TRANSTAT parameter at IMS cold start. Changing the DFSDFxxx TRANSTAT value across a restart has no effect on the default descriptor TRANSTAT value. You can use the TRANSTAT keyword on the **CREATE TRAN** command or the **CREATE TRANDESC** command to override the system default when you create a transaction or transaction descriptor.

## WFI

Specifies the wait-for-input option. This attribute does not apply to Fast Path transactions, which always behave as wait-for-input transactions.

## N

This is not a wait-for-input transaction. This is the default.

## Y

This is a wait-for-input transaction. A message processing or batch processing application program that processes WFI transactions is scheduled and invoked normally. If the transaction to be processed is defined as WFI, the program is allowed to remain in main storage after it has processed the available input messages. The QC status code (no more messages) is returned to the program if the processing limit count (PLCT) is reached; a command is entered to change the status of the scheduled transaction, database, program, or class; commands relating to the databases used by the transaction are entered, or IMS is terminated with a checkpoint shutdown.

Keyword combination rules include the following:

- CMTMODE(MULT) and WFI(Y) are mutually exclusive.

## Usage notes

In an IMSplex where an RM and a resource structure are defined, the transaction names are saved in the resource structure.

Resources exist for the life of the IMS unless they are deleted using a **DELETE** command. Resources are recoverable across an IMS warm start or emergency restart. Resources are lost if IMS is cold started, unless cold start imports definitions that were exported while IMS was up.

The **CREATE TRAN** command is similar to local online change (using a **/MODIFY** command) or global online change (using an **INITIATE OLC** command) for transaction resources in the MODBLKS data set, except that transactions are added dynamically.

The **CREATE TRAN** command can be issued only through the Operations Manager API. These commands apply to DB/DC and DCCTL systems.

This command is not valid on the XRF alternate or FDBR region. The **CREATE** command is not valid if online change for MODBLKS is enabled (DFSDFxxx or DFSCGxxx defined with MODBLKS=OLC or MODBLKS not defined).



## Output fields

The following table shows the **CREATE TRAN** output fields. The columns in the table are as follows:

### Short label

Contains the short label generated in the XML output.

### Keyword

Identifies keyword on the command that caused the field to be generated. N/A appears for output fields that are always returned. The value *error* appears for output fields that are returned only in case of an error.

### Meaning

Provides a brief description of the output field.

*Table 168. Output fields for the CREATE TRAN command*

| Short label | Keyword      | Meaning   |
|-------------|--------------|---|
| CC          | N/A          | Completion code.  |
| CCTXT       | <i>error</i> | Completion code text that briefly explains the meaning of the non-zero completion code. |
| MBR         | N/A          | IMSplex member that built the output line.  |
| TRAN        | TRAN         | Transaction name.   |

## Return, reason, and completion codes

An IMS return and reason code is returned to OM by the **CREATE TRAN** command. The OM return and reason codes that might be returned as a result of the **CREATE TRAN** command are standard for all commands entered through the OM.

The following table includes the return and reason codes and a brief explanation of the codes. The return or reason code returned for the command might also indicate an error from a CSL request.

*Table 169. Return and reason codes for the CREATE TRAN command*

| Return code | Reason code | Meaning   |
|-------------|-------------|---|
| X'00000000' | X'00000000' | Command completed successfully. The command output contains a line for each resource, accompanied by its completion code. See the completion code table for details.  |
| X'00000008' | X'00002009' | Multiple values specified for the same attribute are invalid. For example, you cannot specify both RESP(Y) and RESP(N). This reason code is applicable only when you create a transaction using the DFSINSX0 user exit. |
| X'00000008' | X'0000204C' | The class value is invalid.   |
| X'00000008' | X'00002050' | The current priority CPRI value is invalid.   |
| X'00000008' | X'00002054' | The limit count LCT value is invalid.   |
| X'00000008' | X'00002058' | The limit priority LPRI is invalid.   |
| X'00000008' | X'0000205C' | The maximum region MAXRGN is invalid.   |
| X'00000008' | X'00002060' | The normal priority NPRI value is invalid.  |
| X'00000008' | X'00002064' | The parallel limit count PARLIM value is invalid.   |
| X'00000008' | X'00002068' | The processing limit count PLCT is invalid.   |

Table 169. Return and reason codes for the CREATE TRAN command (continued)

| Return code | Reason code | Meaning   |
|-------------|-------------|---|
| X'00000008' | X'0000206C' | The segment number SEGNO value is invalid.  |
| X'00000008' | X'00002070' | The segment size SEGSZ value is invalid.  |
| X'00000008' | X'00002100' | CMTMODE(MULT) mutually exclusive with WFI(Y). Either both keywords were explicitly specified, or one keyword was explicitly specified and the other attribute was obtained from the model.  |
| X'00000008' | X'00002101' | CONV(Y) mutually exclusive with CMTMODE(MULT). Either both keywords were explicitly specified, or one keyword was explicitly specified and the other attribute was obtained from the model.   |
| X'00000008' | X'00002103' | CONV(N) mutually exclusive with SPASZ>0 or SPATRUNC. Either both keywords were explicitly specified, or one keyword was explicitly specified and the other attribute was obtained from the model.   |
| X'00000008' | X'00002104' | CONV(Y) mutually exclusive with RECOVER(N). Either both keywords were explicitly specified, or one keyword was explicitly specified and the other attribute was obtained from the model.  |
| X'00000008' | X'00002105' | CONV(Y) requires SPASZ and SPATRUNC. Either SPASZ was not explicitly specified or defined in the model, or SPATRUNC was not explicitly specified or defined in the model. CONV(Y) was either explicitly specified or defined in the model.  |
| X'00000008' | X'00002108' | Invalid EDITRTN name. EDITRTN was specified explicitly or obtained from the model.  |
| X'00000008' | X'00002109' | Maximum 255 edit routines exceeded. EDITRTN was specified explicitly or obtained from the model.  |
| X'00000008' | X'0000210A' | Invalid EMHBSZ. One of the following situations occurred: <ul style="list-style-type: none"> <li>• The EMHB size specified is either greater than the maximum size, which is 30720</li> <li>• The EMHB size specified plus the length of the X'5901' log record prefix is greater than the log buffer size</li> </ul> |
| X'00000008' | X'0000210C' | FP(E) mutually exclusive with EDITRTN. Either both keywords were explicitly specified, or one keyword was explicitly specified and the other attribute was obtained from the model.   |
| X'00000008' | X'0000210E' | FP(E) or FP(P) mutually exclusive with MSC keyword, either MSNAME or SIDR and SIDL. Either both keywords were explicitly specified, or one keyword was explicitly specified and the other attribute was obtained from the model.  |
| X'00000008' | X'0000210F' | FP(E) or FP(P) mutually exclusive with MSGTYPE(MULTSEG). Either both keywords were explicitly specified, or one keyword was explicitly specified and the other attribute was obtained from the model.   |

Table 169. Return and reason codes for the CREATE TRAN command (continued)

| Return code | Reason code | Meaning   |
|-------------|-------------|---|
| X'00000008' | X'00002110' | FP(N) mutually exclusive with EMHBSZ > 0. Either both keywords were explicitly specified, or one keyword was explicitly specified and the other attribute was obtained from the model.          |
| X'00000008' | X'00002111' | FP(E) or FP(P) mutually exclusive with RECOVER(N). Either both keywords were explicitly specified, or one keyword was explicitly specified and the other attribute was obtained from the model. |
| X'00000008' | X'00002112' | FP(E) or FP(P) mutually exclusive with RESP(N). Either both keywords were explicitly specified, or one keyword was explicitly specified and the other attribute was obtained from the model.    |
| X'00000008' | X'00002116' | INQ(N) mutually exclusive with RECOVER(N). Either both keywords were explicitly specified, or one keyword was explicitly specified and the other attribute was obtained from the model.         |
| X'00000008' | X'00002117' | Invalid LIKE descriptor name.   |
| X'00000008' | X'00002118' | Invalid LIKE resource name.   |
| X'00000008' | X'00002119' | MSC keyword MSNAME or SIDR and SIDL are mutually exclusive with application program defined as Fast Path exclusive (FP(E)) associated with this transaction.                                    |
| X'00000008' | X'0000211A' | Invalid MSNAME name.  |
| X'00000008' | X'0000211B' | MSNAME mutually exclusive with SIDR and SIDL.   |
| X'00000008' | X'0000211D' | MAXRGN>0 mutually exclusive with PARLIM(65535). Either both keywords were explicitly specified, or one keyword was explicitly specified and the other attribute was obtained from the model.    |
| X'00000008' | X'0000211E' | MAXRGN>0 mutually exclusive with SERIAL(Y). Either keywords were explicitly specified, or one keyword was explicitly specified and the other attribute was obtained from the model.             |
| X'00000008' | X'00002120' | PGM() definition missing. PGM must be defined for local transactions either explicitly or in the model.   |
| X'00000008' | X'00002121' | PARLIM value mutually exclusive with SERIAL(Y). Either both keywords were explicitly specified, or one keyword was explicitly specified and the other attribute was obtained from the model.    |
| X'00000008' | X'00002123' | Invalid PGM name. PGM was specified explicitly, or obtained from the model. If the IMS-defined descriptor DFSDSTR1 was used, the command failed because DFSDSTR1 defines no program name.       |

Table 169. Return and reason codes for the CREATE TRAN command (continued)

| Return code | Reason code | Meaning  |
|-------------|-------------|--|
| X'00000008' | X'00002125' | If REMOTE(Y) is specified, the SIDR value must be a remote SYSID and the SIDL value must be a local SYSID. If neither the MSNAME keyword nor the SIDR and SIDL keywords are specified explicitly, the SIDR and SIDL values are obtained from the model. If REMOTE(N) is specified, the SIDR value must be equal to the SIDL value. The SIDR and SIDL values can be specified explicitly or obtained from the model. The MSNAME keyword is not allowed with REMOTE(N). The REMOTE value can be specified explicitly or obtained from the model. |
| X'00000008' | X'00002126' | Invalid SIDL value.  |
| X'00000008' | X'00002127' | SIDL/SIDR must be specified as a pair. Either SIDL was specified alone or SIDR was specified alone.  |
| X'00000008' | X'00002128' | Invalid SIDR value.  |
| X'00000008' | X'0000212A' | The <b>CREATE TRAN</b> command is rejected for the transaction, because it specifies a batch program and an attribute value that is not allowed for a batch program such as a PARLIM value other than 65535.   |
| X'00000008' | X'00002135' | Parlim/schdtype(serial) conflict. If PARLIM is specified and defined with a value other than 65535 and the program is defined as schdtype(serial), the command is rejected.  |
| X'00000008' | X'00002140' | Fast Path exclusive FP(E) is mutually exclusive with any conversation keyword, including CONV(Y), SPASZ, and SPATRUNC. An FP exclusive transaction cannot be defined as conversational.  |
| X'0000000C' | X'00003000' | Command was successful for some resources but failed for others. The command output contains a line for each resource, accompanied by its completion code. See the completion code table for details.  |
| X'0000000C' | X'00003004' | Command was not successful for any of the resources. The command output contains a line for each resource, accompanied by its completion code. See the completion code table for details.  |
| X'00000010' | X'0000400C' | Command is not valid on the XRF alternate.   |
| X'00000010' | X'00004024' | No Fast Path defined, so FP(E), FP(P), or EMHBSZ > 0 is invalid.   |
| X'00000010' | X'00004120' | Online change phase is in progress.  |
| X'00000010' | X'00004204' | Model is quiesced. Cannot quiesce model.   |
| X'00000010' | X'00004300' | Command is not allowed because online change for MODBLKS is enabled (DFSDFxxx or DFSCGxxx defined with MODBLKS=OLC, or MODBLKS not defined).   |
| X'00000010' | X'00004310' | Storage could not be obtained for the Transaction Input edit routine table. A cold start is required to fix this error.  |
| X'00000010' | X'00004314' | The Transaction Input edit routine could not be loaded.  |

Table 169. Return and reason codes for the CREATE TRAN command (continued)

| Return code | Reason code | Meaning  |
|-------------|-------------|--|
| X'00000010' | X'00004318' | A new Transaction Input edit routine could not be added. The maximum of 255 routines has already been reached.   |
| X'00000014' | X'00005004' | DFSOCMD response buffer could not be obtained.   |
| X'00000014' | X'00005008' | DFSPPOOL storage could not be obtained.  |
| X'00000014' | X'0000500C' | AWE could not be obtained.   |
| X'00000014' | X'00005010' | Unable to obtain latch.  |
| X'00000014' | X'00005114' | Resource or descriptor that is specified as a model is in the process of being imported from the change list in the IMSRSC repository or was not imported successfully from the change list at the end of IMS restart. This resource or descriptor cannot be referenced as a model on a <b>CREATE</b> command until it is successfully imported from the repository. |

The following table includes an explanation of the completion codes.

Table 170. Completion codes for the CREATE TRAN command

| Completion code | Completion code text       | Meaning  |
|-----------------|----------------------------|--|
| 0               |                            | Command completed successfully for transaction.  |
| 11              | RESOURCE ALREADY EXISTS    | Transaction already exists.  |
| 17              | ANOTHER CMD IN PROGRESS    | Another command (such as <b>DELETE PGM</b> or <b>UPDATE PGM</b> ) is in progress for the program referenced by this transaction. |
| 22              | CPIC TRAN ALREADY EXISTS   | CPI-C transaction already exists by that name.   |
| 36              | FP=E/FP=N PGM CONFLICT     | Transaction to be created as Fast Path exclusive FP(E) conflicts with program already defined as non-Fast Path FP(N).            |
| 3E              | FP=N/FP=E PGM CONFLICT     | Transaction to be created as non-Fast Path FP(N) conflicts with program already defined as Fast Path exclusive FP(E).            |
| 3F              | FP=P/BMPTYPE=Y CONFLICT    | Transaction to be created as Fast Path potential FP(P) conflicts with the program defined as batch BMPTYPE(Y).                   |
| 4E              | LTERM ALREADY EXISTS       | LTERM already exists by that name.   |
| 5B              | MSNAME ALREADY EXISTS      | MSNAME already exists by that name.  |
| 5F              | INVALID CHARACTERS IN NAME | Name is invalid because it contains an invalid character.  |
| 61              | DFSBCB STORAGE ERROR       | Request to get BCB storage for SMB control block failed.   |

Table 170. Completion codes for the CREATE TRAN command (continued)

| Completion code | Completion code text             | Meaning   |
|-----------------|----------------------------------|---|
| 6A              | FP=P/FP=E PGM CONFLICT           | Transaction to be created as Fast Path potential FP(P) conflicts with program already defined as Fast Path exclusive FP(E).   |
| 78              | RM CONFLICT                      | LTERM, CPIC transaction, MSNAME, or descriptor already exists in RM by that name.   |
| 8A              | WILDCARD PARAMETER NOT SUPPORTED | The <b>CREATE</b> command does not support wildcard parameters. You must explicitly specify the names of the resources you want to create.  |
| 90              | INTERNAL ERROR                   | An IMS system service failure.  |
| 93              | RESERVED NAME                    | Name is reserved. For example, name starts with DFS (except for DFSSAMxx or DFSIVPxx), or is an IMS reserved name such as BASICEDT or WTOR.   |
| B5              | ROUTING CODE ALREADY EXISTS      | Transaction creation failed for a Fast Path exclusive FP(E) transaction. The routing code could not be created, because one already exists with the same name as the transaction to be created. |
| B6              | LATCH ERROR                      | Unable to obtain latch.   |

### Examples

The following are examples of the **CREATE TRAN** command:

#### Example 1 for CREATE TRAN command

TSO SPOC input:

```
CREATE TRAN NAME(TRN00001,TRN00002) LIKE(RSC(APOL18))
SET(NPRI(6),LPRI(10),TRANSTAT(Y),CLASS(2))
```

TSO SPOC output:

```
Response for: CREATE TRAN NAME(TRN00001,TRN00002) LIKE(RSC(APO...
Trancode MbrName CC
TRN00001 IMS1 0
TRN00002 IMS1 0
```

OM API input:

```
CMD(CRE TRAN NAME(TRN00001,TRN00002) LIKE(RSC(APOL18))
SET(NPRI(6),LPRI(10),TRANSTAT(Y),CLASS(2))
```

OM API output:

```
<imsout>
<ctl>
<omname>OM10M </omname>
<omvsn>1.3.0</omvsn>
<xm1vsn>20 </xm1vsn>
```

```

<statime>2006.307 19:23:15.095304</statime>
<stotime>2006.307 19:23:15.096942</stotime>
<staseq>BFA6CF3A7E308C1C</staseq>
<stoseq>BFA6CF3A7E96EA52</stoseq>
<rqsttkn1>USRT011 10112315</rqsttkn1>
<rc>00000000</rc>
<rsn>00000000</rsn>
</ctl>
<cmd>
<master>IMS1 </master>
<userid>USRT011 </userid>
<verb>CRE </verb>
<kwd>TRAN </kwd>
<input>CREATE TRAN NAME(TRN00001,TRN00002) LIKE(RSC(APOL18))
SET(NPRI(6),LPRI(10),TRANSTAT(Y),CLASS(2)) </input>
</cmd>
<cmdsphdr>
<hdr slbl="TRAN" llbl="Trancode" scope="LCL" sort="a" key="1"
scroll="no" len="8" dtype="CHAR" align="left" />
<hdr slbl="MBR" llbl="MbrName" scope="LCL" sort="a" key="2" scroll="no"
len="8" dtype="CHAR" align="left" />
<hdr slbl="CC" llbl="CC" scope="LCL" sort="n" key="0" scroll="yes"
len="4" dtype="INT" align="right" skipb="no" />
<hdr slbl="CCTXT" llbl="CCText" scope="LCL" sort="n" key="0"
scroll="yes" len="*" dtype="CHAR" skipb="yes" align="left" />
</cmdsphdr>
<cmdsdata>
<rsp>TRAN(TRN00001) MBR(IMS1) CC( 0) </rsp>
<rsp>TRAN(TRN00002) MBR(IMS1) CC( 0) </rsp>
</cmdsdata>
</imsout>

```

**Explanation:** Transactions named TRN00001 and TRN00002 are created like transaction APOL18, with several attributes specified with the SET keyword to override those attributes obtained from transaction APOL18.

### Related concepts

[How to interpret CSL request return and reason codes \(System Programming APIs\)](#)

### Related reference

[“Command keywords and their synonyms” on page 59](#)

All IMS command keywords and their synonyms, as well as keywords supported by the OM API, are listed. The list covers command keywords for the OM command processing clients such as IMS, ODBM, IMSCON, and RM.

[Commit Verify exit routine \(Exit Routines\)](#)

## CREATE TRANDESC command

Use the **CREATE TRANDESC** command to create transaction descriptors. A descriptor is a model that can be used to create descriptors or resources.

A descriptor is created with a value set for every attribute. Attributes not explicitly specified on the **CREATE** command take the default value. Any transaction descriptor can be created using this descriptor as a model, by specifying the **CREATE** command with LIKE(DESC(descriptor\_name)).

Subsections:

- [“Environment” on page 308](#)
- [“Syntax” on page 308](#)
- [“Keywords” on page 310](#)
- [“Usage notes” on page 322](#)
- [“Output fields” on page 323](#)
- [“Return, reason, and completion codes” on page 323](#)
- [“Examples” on page 327](#)

## Environment

The following table lists the environments (DB/DC, DBCTL, and DCCTL) in which you can use the command and keywords.

Table 171. Valid environments for the CREATE TRANDESC command and keywords

| Command / Keywords     | DB/DC | DBCTL | DCCTL |
|------------------------|-------|-------|-------|
| <b>CREATE TRANDESC</b> | X     |       | X     |
| LIKE                   | X     |       | X     |
| NAME                   | X     |       | X     |
| SET                    | X     |       | X     |

## Syntax

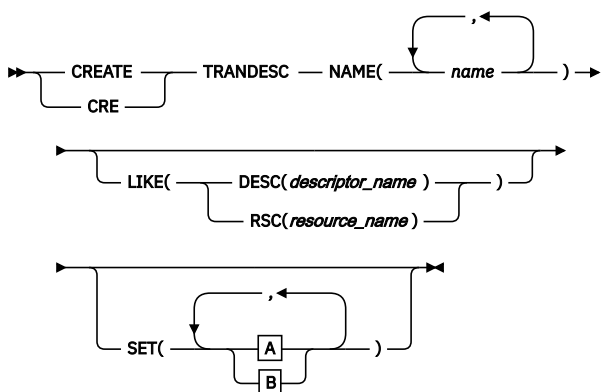

A



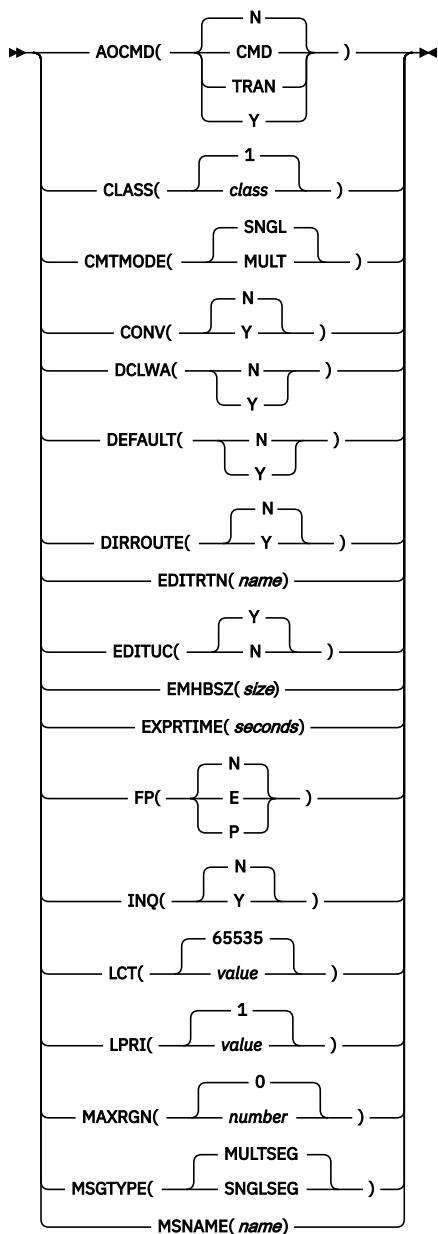

**B**

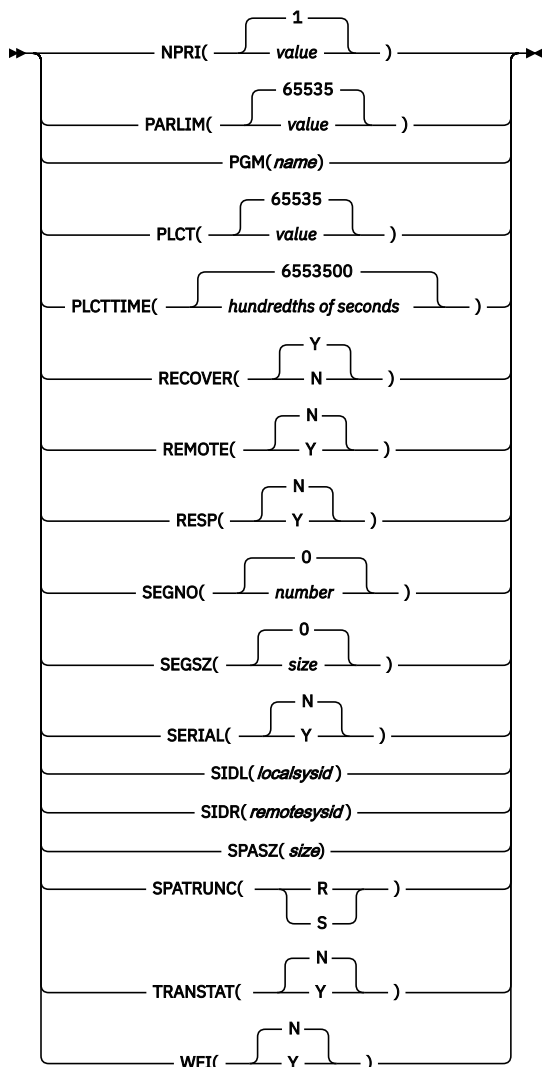

Default values shown in this syntax diagram reflect the default values that are defined in the IMS transaction descriptor, DFSDSTR1. If you define another descriptor as the default with a **CREATE** or **UPDATE TRANDESC** command, the default values shown in this syntax diagram might not match the value defined in the current default descriptor.

## Keywords

The following keywords are valid for the **CREATE TRANDESC** command:

### LIKE

Specifies that the descriptor is created using an existing descriptor as a model, instead of the default descriptor. The default descriptor is either the IMS descriptor DFSDSTR1, or user-defined. The model type can either be a descriptor (DESC), or a resource (RSC). The descriptor is created with all the same attributes as the model, except for the DEFAULT(Y) value and the CPRI value, which is a runtime scheduling value that does not apply to transaction descriptors. Attributes set explicitly by the **CREATE** command override the model attributes. DEFAULT(Y) must be specified explicitly to make a descriptor the default descriptor. Later changes to the model are not propagated to resources or descriptors that were created from it.

The **QUERY** commands can be used to display the model name and model type used to create the descriptor or resource. The model name and type returned from the **QUERY** command are provided for informational purposes only. The **EXPORT** command exports a resource definition including the model

name and model type to the definition member. The **IMPORT** command imports a resource definition including the model name and model type from the definition member. An **IMPORT** command that creates a resource saves the model name and model type, but does not use the models attributes.

**DESC(descriptor\_name)**

Specifies the name of the descriptor to use as a model to define this descriptor.

**RSC(resource\_name)**

Specifies the name of the resource to use as a model to define this descriptor.

**NAME**

Specifies the 1-8 character name of the transaction. Names must be alphanumeric (A through Z, 0 through 9, #, \$, and @). Names cannot include a blank, comma, period, hyphen, or equal sign. Names cannot begin with DFS, except for DFSIVPxx and DFSSAMxx. Names cannot be BASICEDT, DBCDM, DBRC, ISCEDT, MSDB, SDB, or WTOR. A transaction resource and a transaction descriptor can have the same name. A transaction cannot have the same name as a logical terminal.

**SET**

Specifies the attributes of the transaction to be created. If the LIKE keyword is omitted, attributes not specified take the value defined in the default descriptor, which is either the IMS descriptor DFSDSTR1, or user-defined. If the LIKE keyword is specified, attributes not specified take the value defined in the model. A transaction must have the same characteristics in all systems where it is defined when it is shared. These characteristics include:

- Nonconversational or conversational
- SPA size if conversational
- Single- or multi-segment messages
- Noninquiry or inquiry
- Recoverable or nonrecoverable
- Response mode or non-response mode
- Fast Path exclusive, Fast Path potential, or non-Fast Path

**AOCMD**

Specifies the AOI option indicating whether the transaction can issue the type-1 AOI CMD call or the type-2 AOI ICMD call. If AOCMD is defined as CMD, TRAN, or Y, and the AOI1 execute parameter is defined as AOI1=N, no authorization checking is done, and the transaction is permitted to issue CMD and ICMD calls.

**N**

Indicates that the transaction is not permitted to issue type-1 AOI CMD calls. The transaction is permitted to issue type-2 AOI ICMD calls.

**CMD**

Indicates that the transaction is permitted to issue type-1 AOI CMD calls and type-2 AOI ICMD calls. If the AOI1 execute parameter is defined as C, R, or A, authorization checking is based on which transactions can issue a particular command. In this case, the commands (or the first three characters of the commands) need to be defined to RACF or an equivalent product as a user. The type-1 AOI transactions must be defined as profiles under the TIMS class, and for each transaction, the commands it can issue must be specified. Defining AOCMD(CMD) requires you to create fewer user IDs than you need to create for the AOCMD(TRAN) definition. However, defining AOCMD(CMD) requires you to create or modify a larger number of resource profiles.

**TRAN**

Indicates that the transaction is permitted to issue type-1 AOI CMD calls and type-2 AOI ICMD calls. If the AOI1 execute parameter is defined as C, R, or A, the transaction code is used for authorization. The first authorization check results in the accessor environment element (ACEE) being built. This environment is kept for use by future authorization checks. The type-1 AOI transaction needs to be defined to RACF or an equivalent product as a user. The transactions will then be specified on RACF PERMIT statements for each command they are allowed to issue from a

type-1 AOI transaction. Specifying AOI transactions as users to RACF might conflict with the name of a user already defined to RACF. If this occurs, then either the transaction name or the existing user name needs to be changed.

## Y

Indicates that the transaction is permitted to issue type-1 AOI CMD calls and type-2 AOI ICMD calls. If the AOI1 execute parameter is defined as C, R, or A, the user ID or the program name is used for authorization. For some environments, if a Get Unique call has not yet occurred, the program name is used for authorization.

## CLASS

Specifies the transaction class, which is an attribute used to select a transaction for scheduling. A transaction can be scheduled if there is a message processing region available for that class. The value can be a number from 1 to 999. The default is 1. This value must not exceed the value given (by specification or default) on the MAXCLAS= keyword of the IMSCTRL macro.

Define CPI-C transactions with a different message class from that used for non-CPI-C transactions. IMS handles all CPI-C transactions as priority zero within the transaction class.

## CMTMODE

Specifies when database updates and non-express output messages are committed. This operand affects emergency restart.

### MULT

Database updates and non-express output messages are committed only when the application program terminates normally, when the processing limit count has been reached, or, in the case of a pseudo-WFI dependent region, when there are no more messages on the queue. For example, if five transactions are processed during a single schedule of a program, all five are committed only when the fifth one is completed and the program terminates. Until a transaction has been committed, locks for updated database records are not released and non-express output messages are not queued for output. If an application ends abnormally before committing its messages, emergency restart requeues all the messages that were processed within the commit scope and makes them available for reprocessing.

If the transaction results in the application calling an external subsystem, such as DB2, the Commit Verify exit provided by the external subsystem can determine whether CMTMODE(MULT) is supported. See documentation under the Commit Verify exit routine in *IMS Version 15.3 Exit Routines*.

### SNGL

Database updates and non-express output messages are committed when the application program completes processing each transaction. IMS invokes commit processing either when the application program requests the next message (issues a GU to the IO-PCB), or when the application program terminates. If an application ends abnormally before committing its message, emergency restart requeues the message that was in process before the abend and makes it available for reprocessing. This is the default.

The TRANSACT macro MODE keyword uses a default of MULT. The **CRE TRAN** command CMTMODE keyword uses a default of SNGL.

Keyword combination rules include the following:

- CONV(Y) and CMTMODE(MULT) are mutually exclusive.
- CMTMODE(MULT) and WFI(Y) are mutually exclusive.

## CONV

Specifies the conversation option.

## N

The transaction is not conversational. This is the default.

## Y

The transaction is conversational. The transaction message is destined for a conversational program. A conversational program processes transactions made up of several steps. A conversational program receives a message from a terminal, replies to the terminal, but saves the data from the transaction in a scratchpad area (SPA). When the person at the terminal enters more data, the program has the data it saved from the last message in the SPA, so it can continue processing the request without the person at the terminal having to enter the data again.

Keyword combination rules include the following:

- CMTMODE(MULT) and CONV(Y) are mutually exclusive.
- CONV(Y) requires SPASZ and SPATRUNC.
- INQ(Y) and CONV(Y) are mutually exclusive.
- RECOVER(N) and CONV(Y) are mutually exclusive.
- SPASZ and CONV(N) are mutually exclusive.
- SPATRUNC and CONV(N) are mutually exclusive.

## DCLWA

Specifies the log write-ahead option. If not specified, the value is defined to be the DCLWA parameter in the DFSDFxxx PROCLIB member. If DCLWA is not defined in the DFSDFxxx PROCLIB member, the default is DCLWA=Y.

## N

IMS should not perform log write-ahead. Specify N if input message integrity and the consistency of output messages with associated database updates is not required. DCLWA does not apply to response mode or Fast Path input processing, and is ignored during IMS execution.

## Y

IMS should perform log write-ahead for recoverable, nonresponse input messages and transaction output messages. This ensures the following:

- A nonresponse input transaction is made recoverable across IMS failures before IMS acknowledges receipt of the input.
- Database changes are made recoverable before IMS sends associated output reply messages.
- Information in the log buffers is written to the IMS log, before the associated input acknowledgment or output reply is sent to the terminal.

Define DCLWA(Y) for all VTAM terminal types.

## DEFAULT

Specifies whether the descriptor is the default.

## N

The descriptor is not the default.

## Y

The descriptor is the default, which resets the existing default descriptor to DEFAULT(N). When a descriptor or resource is created without the LIKE keyword, any attribute not specified on the **CREATE** command takes the value defined in the default descriptor. Only one descriptor can be defined as the default for a resource type. IMS defines a default transaction descriptor called DFSWSTR1, where all attributes are defined with the default value. Defining a user-defined descriptor as the default overrides the IMS-defined descriptor. Since only one transaction descriptor can be the default at one time, only one transaction name can be specified with DEFAULT(Y).

## DIRROUTE

Specifies the MSC directed routing option.

## N

The application program processing a transaction is not informed of the system which originated the transaction. The name of the originating LTERM is placed in the I/O PCB. This is the default.

## Y

The application program processing a transaction is informed of the system which originated the transaction, if MSC directed routing is used in a multiple IMS system configuration. An MSNAME corresponding to a logical path back to the originating system is placed in the I/O PCB.

## EDITRTN

Specifies the one- to eight-character name of your transaction input edit routine that edits messages before the program receives the message. This name must begin with an alphabetic character. The specified edit routine (load module) must reside on the USERLIB data set. This routine cannot be the same as the one defined by the system definition TYPE EDIT= parameter. A maximum of 255 input edit routines are supported.

EDITRTN is used for a Fast Path potential transaction when the transaction is routed to IMS.

For input from LU 6.2 devices, the user edit exit routine DFSLUEE0 is called instead of the transaction input edit routine specified in EDITRTN.

Keyword combination rules include the following:

- FP(E) and EDITRTN are mutually exclusive.

## EDITUC

Specifies the edit to uppercase option.

### N

The input data is not translated to uppercase. It can consist of upper and lowercase characters as entered from the terminal.

### Y

The input data is to be translated to uppercase before it is presented to the processing program. If FP(E) or FP(P), the transaction is to be translated to uppercase before being presented to the edit/routing exit routine. This is the default.

Specifying EDITUC(Y) for VTAM terminals prevents the transmission of embedded device control characters.

## EMHBSZ

Specifies the EMH buffer size required to run the Fast Path transaction. This overrides the EMHL execution parameter. If EMHBSZ is not specified, the EMHL execution parameter value is used. The value can be a number from 12 to 30720.

Keyword combination rules include the following:

- EMHBSZ>0 requires Fast Path to be defined.
- FP(N) and EMHBSZ>0 are mutually exclusive.

## EXPTIME

Specifies the elapse time in seconds that IMS can use to cancel the input transaction. After a transaction is submitted to IMS, the transaction could be delayed for processing because of a stopped transaction or a potential system slow down. In that case, the user or client application could time out before the transaction is processed. When IMS eventually schedules and processes the transaction, the response message is no longer wanted. With the elapse time specified for the transaction, IMS can flag the input transaction as expired so that the system does not waste CPU cycles to process the unwanted transaction.

The value can be a number, in seconds, which can range from 0 to 65535. The default is 0, which means that no expiration time is set for this transaction. The transaction expiration attribute is supported by all of the IMS TM interfaces.

**Restriction:** The transaction expiration checking is not performed at the GU time for Fast Path transactions, IMS conversational transactions, program-to-program switch transactions, and APPC synchronous transactions.

## FP

Specifies the Fast Path option.

**E**

The transaction is processed exclusively as Fast Path. A Fast Path routing code by the same name is created. The program must be defined as Fast Path exclusive.

**N**

The transaction is not a candidate for Fast Path processing. The program identified by PGM() must be defined as not Fast Path. This is the default.

**P**

The transaction is a potential candidate for Fast Path processing. Fast Path-potential transactions must be able to run under two programs: a Fast Path exclusive program a non-Fast Path program. This **CREATE TRAN** command defines the non-Fast Path program with PGM(). A Fast Path exclusive program should be defined to which this transaction can be routed. Fast Path-potential transactions must be processed by a user edit/routing exit to determine whether the transaction is actually to be processed by IMS Fast Path. If it is to be processed by IMS Fast Path, the edit/routing exit routine associates the transaction with a routing code. This routing code identifies which Fast Path program is to process the transaction.

The program defined by PGM() must not be defined as Fast Path exclusive.

Keyword combination rules include the following:

- EDITRTN and FP(E) are mutually exclusive.
- FP(P) and FP(E) require Fast Path to be defined.
- MSGTYPE(MULTSEG) and FP(E) are mutually exclusive.
- MSGTYPE(MULTSEG) and FP(P) are mutually exclusive.
- MSNAME and FP(E) are mutually exclusive.
- MSNAME and FP(P) are mutually exclusive.
- RECOVER(N) and FP(E) are mutually exclusive.
- RECOVER(N) and FP(P) are mutually exclusive.
- RESP(N) and FP(E) are mutually exclusive.
- RESP(N) and FP(P) are mutually exclusive.
- SIDL and FP(E) are mutually exclusive.
- SIDL and FP(P) are mutually exclusive.
- SIDR and FP(E) are mutually exclusive.
- SIDR and FP(P) are mutually exclusive.

**INQ**

Specifies the inquiry option.

**N**

This is not an inquiry transaction. This is the default.

**Y**

This is an inquiry transaction. If INQ(Y) is specified, you can also specify whether this transaction should be recovered during an IMS emergency or normal restart using the RECOVER() parameter.

This should be specified only for those transactions that, when entered, do not cause a change in any database. Programs are prohibited from issuing ISRT, DLET, or REPL calls to a database when scheduled to process a transaction defined as INQ(Y).

An application program cannot do an SQL INSERT, DELETE, or UPDATE when the IMS transaction is defined with INQ(Y).

Keyword combination rules include the following:

- CONV(Y) and INQ(Y) are mutually exclusive.
- RECOVER(N) and INQ(N) are mutually exclusive.

## **LCT**

Specifies the limit count. This is the number that, when compared to the number of input transactions queued and waiting to be processed, determines whether the normal or limit priority value is assigned to this transaction. The value can be a number from 1 to 65535. The default is 65535.

The limit count value is ignored for a transaction processed by a BMP.

The limit count value is ignored in a shared queues environment.

## **LPRI**

Specifies the limit priority. This is the scheduling priority to which this transaction is raised when the number of input transactions enqueued and waiting to be processed is equal to or greater than the limit count value. The scheduling priority is an attribute used to select a transaction for scheduling. A transaction of higher priority is scheduled before a lower priority one, if they are defined with the same class. The value can be a number from 0 through 14. The default is 1.

When the limit priority is used and the scheduling priority is raised to the limit priority, the priority is not reduced to the normal priority until all messages enqueued for this transaction name are processed. If you do not want the limit priority for this transaction, define equal values for the normal priority and limit priority, and a limit count of 65535.

When a transaction is processed exclusively by a batch message program (BMP), define the limit priority as 0. If the program specified by PGM() is defined with a program type of batch, the current priority is forced to be 0. However, a batch message processing region (BMP) can process transactions with current scheduling priorities other than 0.

This priority also controls the priority of messages created by this transaction and sent to a destination in a remote system. See also the discussion on MSC priorities under the NPRI definition.

The limit priority value is ignored for a transaction processed by a BMP.

The limit priority value is ignored in a shared-queues environment.

## **MAXRGN**

Specifies the maximum region count. This count value limits the number of message processing program (MPP) regions that can be concurrently scheduled to process a transaction. When the number of MPP regions is not limited, one transaction might monopolize all available regions. The value can be a number from 0 to the value specified on the MAXPST= control region parameter. The default of MAXRGN(0) means that no limit is imposed.

If you define the program with a scheduling type of SERIAL, omit the MAXRGN keyword or define it as 0.

The following keyword combinations are mutually exclusive:

- PARLIM(65535) and MAXRGN value greater than 0
- SERIAL(Y) and MAXRGN value greater than 0

## **MSGTYPE**

Specifies the message type (single segment or multiple segment). It specifies the time at which an incoming message is considered complete and available to be routed to an application program for subsequent processing.

If MSC-directed routing is used in a multiple IMS system configuration, IMS does not ensure that both the message and the transaction destined to process that message are either single segment or multiple segments.

## **MULTSEG**

The incoming message can be more than one segment in length. It is not eligible for scheduling to an application program until an end-of-message indication is received, or a complete message is created by MFS. This is the default.



## **SNGLSEG**

The incoming message is one segment in length. It becomes eligible for scheduling when the terminal operator indicates end-of-segment.

Keyword combination rules include the following:

- FP(E) and MSGTYPE(MULTSEG) are mutually exclusive.
- FP(P) and MSGTYPE(MULTSEG) are mutually exclusive.

## **MSNAME**

Specifies the one- to eight-character name of the logical link path in a multiple IMS system configuration (MSC). A logical link path is a path between any two IMS systems. The IMS systems are identified by the remote system ID and the local system ID associated with the logical link path. The remote system ID identifies the system in which messages using this path are to be processed. The local system ID identifies this system. If this transaction is exported, the local and remote system IDs are exported, not the msname. For a **CREATE TRAN** command adding a remote transaction, the MSNAME must already be defined.

Keyword combination rules include the following:

- FP(E) and MSNAME are mutually exclusive.
- FP(P) and MSNAME are mutually exclusive.
- SIDL and MSNAME are mutually exclusive.
- SIDR and MSNAME are mutually exclusive.

## **NPRI**

Specifies the normal scheduling priority. The scheduling priority is an attribute used to select a transaction for scheduling. A transaction of higher priority is scheduled before a lower priority one, if they are defined with the same class. When a transaction resource is created, the current priority (CPRI), or the scheduling priority, is initialized to the normal priority (NPRI). The normal priority is also assigned to a transaction as the current priority when the number of input transactions enqueued and waiting to be processed is less than the limit count value. The value can be a number from 0 through 14. The default is 1.

This priority also controls the priority of messages created by this transaction and sent to a destination in a remote system.

When a transaction is processed exclusively by a batch message program (BMP), code the normal priority as 0.

When a transaction is processed exclusively by a batch message program (BMP), define the limit priority as 0. If the program specified by PGM() is defined with a program type of batch, the current priority is forced to be 0. However, a batch message processing region (BMP) can process transactions with current scheduling priorities other than 0.

For remote transactions, the priority used to send the transaction to the processing system, which is termed the MSC link message priority. The three MSC link message priority groups are:

- Low
- Medium
- High

The low priority group consists of primary requests in the input terminal system. This group is assigned remote transaction priorities from 0 to 6. The medium group consists of secondary requests, responses, primary requests in an intermediate system, and primary requests in the input terminal system. This group is assigned a remote transaction priority of 7. The high group consists of primary requests in the input terminal system. Messages in this group are assigned remote transaction priorities from 8 to 14. Within each group, messages have a priority based on the current priority value of the transaction or remote transaction in the input terminal system for primary requests, and on the latest processing system for secondary requests and responses.

In an MSC configuration, the transaction priority determines the priority used to send messages inserted by this transaction across an MSC link. If the transaction inserts multiple messages to the same destination (for example, pages to a printer) and these messages must be sent in the order inserted, the normal and limit priority values should be the same. If the normal and limit priority values are not identical, messages inserted at a higher priority than previously inserted messages could arrive at their destination first. (This restriction does not apply to multiple segments of the same message.)

The normal priority value is ignored for a transaction processed by a BMP.

## **PARLIM**

Specifies the parallel processing limit count. This is the maximum number of messages that can currently be queued, but not yet processed, by each active message region currently scheduled for this transaction. This is the threshold value to be used when the associated program is defined with a scheduling type of parallel. An additional region is scheduled whenever the current transaction enqueue count exceeds the PARLIM value multiplied by the number of regions currently scheduled for this transaction.

The value can be a number from 0 to 32767 or 65535. PARLIM(0) indicates that any input message can cause a new region to be scheduled because the scheduling condition is always being met (the number of messages are greater than zero). If you specify PARLIM(0), you should specify a MAXRGN value to limit the number of regions that can be scheduled to process a particular transaction. PARLIM(65535) means that parallel processing is disabled and IMS allows the transaction to be scheduled in only one region at a time. PARLIM(65535) is the default.

The value specified for PARLIM applies to message processing programs (MPPs) only; it is not supported for batch message processing programs (BMPs).

If you define the transaction as serial or the program with a scheduling type as SERIAL, define PARLIM(65535).

In a shared-queues environment (when the scheduling type is PARALLEL), any PARLIM value other than 65535 causes a new region to be scheduled whenever the successful consecutive GU count exceeds the PARLIM value multiplied by the number of regions currently scheduled for this transaction. For shared-queues environments, the successful consecutive GU count is used instead of the queue count. New regions continue to be scheduled up to the maximum number of regions specified on MAXRGN.

Keyword combination rules include the following:

- MAXRGN>0 and PARLIM(65535) are mutually exclusive.
- SERIAL(Y) and PARLIM value 0 - 32767 are mutually exclusive.

## **PGM**

Specifies the name of the program associated with the transaction.

For a **CREATE TRANDESC** command, the program does not need to exist until a **CREATE TRAN** command creates a transaction using the transaction descriptor.

## **PLCT**

Specifies the processing limit count. This is maximum number of messages sent to the application program by IMS for processing without reloading the application program. The value must be a number from 0 through 65535. PLCT(0) means the maximum number of messages sent to the application is one and the application program is reloaded before receiving a subsequent message. PLCT(65535) means that no limit is to be placed upon the number of messages processed at a single program load. Values 1 through 65535 are eligible for quick reschedule processing. The default is 65535.

The value is used to determine how many messages an application program is allowed to process in a single scheduling cycle. When the application program requests, and receives, the number of messages indicated, any subsequent requests result in one of two actions.

- IMS indicates “no more messages exist” if any of the following conditions is true:

- The region is not an MPP.
- The currently scheduled mode is not CMTMODE(SNGL).
- Equal or higher priority transactions are enqueued for the region.

IMS might have other messages enqueued for the application program. It is the responsibility of the application program to terminate when it receives an indicator that no more messages are available. Termination of the application program makes the region it occupied available for rescheduling. This feature makes it possible for IMS to enable scheduling of higher priority transactions that entered the system while the previous transactions were in process. In addition, if any equal-priority transactions are enqueued, they become eligible for scheduling on a first-in, first-out (FIFO) basis.

- The region goes through quick reschedule and returns the next message to the application if all of the following conditions are true:
  - The region is an MPP.
  - The transaction is CMTMODE(SNGL).
  - No equal or higher transactions are enqueued.
  - Messages are still enqueued for the application program.

## PLCTTIME

Specifies the processing limit count time. This is the amount of time (in hundredths of seconds) allowable to process a single transaction (or message). The number specifies the maximum CPU time allowed for each message to be processed in the message processing region.

Batch Message Programs (BMPs) are not affected by this setting.

The value can be a number, in hundredths of seconds, that can range from 1 to 6553500. A value of 6553500 means no time limit is placed on the application program. The default is 6553500.

If Fast Path is used this specifies, for a given transaction name, the amount of time (in hundredths of seconds) the program is allowed to process a single transaction message. The time represents real time that elapses during transaction processing (not accumulated task time). Real time is used because the input terminal is in response mode and cannot enter another transaction until the response is sent. In this case PLCT() is ignored.

The value controls application program looping. You are not required to optimize the value for program-transaction execution time. However, the time value assigned should not be less than the expected per-transaction execution time. If the scheduled application program exceeds the product of PLCTTIME() and PLCT(), the application program ends abnormally. If an IMS STIMER value of 2 is specified on the DFSMPR procedure, the region does not abend until completion of the DL/I call.

**Important:** The application program must not use STIMER timer services. IMS uses STIMER timer services to time the execution of transactions. If an application program issues an MVS STIMER macro, it cancels the STIMER timer services set by IMS. Use the STIMERM macro instead for application program timer requests.

## RECOVER

Specifies the recovery option.

### N

The transaction should not be recovered.

### Y

The transaction should be recovered during IMS emergency or normal restart. This is the default.

Keyword combination rules include the following:

- CONV(Y) and RECOVER(N) are mutually exclusive.
- FP(E) and RECOVER(N) are mutually exclusive.
- FP(P) and RECOVER(N) are mutually exclusive.
- INQ(N) and RECOVER(N) are mutually exclusive.

## REMOTE

Specifies the remote option.

### N

The transaction is not remote. The transaction is local and runs on the local system. This is the default.

### Y

The transaction is remote. The transaction runs on a remote system.

Keyword combination rules include the following:

- REMOTE(Y) requires MSNAME or SIDR and SIDL.

## RESP

Specifies the response-mode option.

### N

The transaction is not response mode. For terminals specifying or accepting a default of OPTIONS=TRANRESP, input should not stop after this transaction is entered. This is the default.

### Y

The transaction is response mode. The terminal from which the transaction is entered is held and prevents further input until a response is received. For terminals specifying or accepting a default of OPTIONS=TRANRESP, no additional messages are to be allowed after this transaction is entered until this transaction sends a response message back to the terminal. Response mode can be forced or negated by individual terminal definition. RESP(Y) is ignored during online processing for all terminals that do not operate in response mode.

Keyword combination rules include the following:

- FP(E) and RESP(N) are mutually exclusive.
- FP(P) and RESP(N) are mutually exclusive.

## SEGNO

Specifies the segment number. This is the maximum number of application program output segments that are allowed into the message queues per Get Unique (GU) call from the application program. The value can be a number from 0 through 65535. The default is 0. If SEGNO(0) is defined, the number of segments is not checked by the online system at execution time.

## SEGSZ

Specifies the segment size. This is the maximum number of bytes allowed in any one output segment. The value can be a number from 0 through 65535. The default is 0. If SEGSZ(0) is defined, the segment size is not checked by the online system at execution time.

The maximum output message segment to an LU 6.2 device is 32767. If a transaction is expected to send output to an LU 6.2 device, the SEGSIZE parameter should be no greater than 32767. However, this is not enforced during processing of the command, because IMS cannot determine the device type for the message destination until output time.

## SERIAL

Specifies the serial option.

### N

Messages for the transaction are not processed serially. Message processing can be processed in parallel. Messages are placed on the suspend queue after a U3303 pseudoabend. Scheduling continues until repeated failures result in the transaction being stopped with a USTOP. This is the default.

### Y

Messages for the transaction are processed serially. U3303 pseudoabends do not cause the message to be placed on the suspend queue but rather on the front of the transaction message queue, and the transaction is stopped with a USTOP. The USTOP of the transaction is removed when the transaction or the class is started with a **/START** or **UPD TRAN** command.

Keyword combination rules include the following:

- MAXRGN>0 and SERIAL(Y) are mutually exclusive.
- PARLIM value 0 - 32767 and SERIAL(Y) are mutually exclusive.

### **SIDL**

Specifies the system identification (SYSID) of the local system in a multiple-IMS system (MSC) configuration. The local system is the originating system to which responses are returned. The value can be a number from 1 to 2036. The local SYSID can be defined in any or all of the MSNAMEs or transactions.

For a local transaction where SIDL is not specified, SIDL is defined with a value of the lowest system ID when MSC is enabled on this system, or SIDL is defined with a value of 0 when MSC is not enabled on this system. The local system ID and remote system ID are the same for local transactions.

The SIDL parameter is independent of the link type (CTC, MTM, TCP/IP, VTAM) specified on the TYPE= keyword of the MSPLINK macro statement.

Keyword combination rules include the following:

- FP(E) and SIDL are mutually exclusive, unless SIDL and SIDR are specified as a pair and are equal to the local system ID of this IMS.
- FP(P) and SIDL are mutually exclusive.
- MSNAME and SIDL are mutually exclusive.
- SIDL value must be defined to this IMS.

### **SIDR**

Specifies the system identification (SYSID) of the remote system in a multiple-IMS system (MSC) configuration. The remote system is the system on which the application program executes. The value can be a number from 1 to 2036. The remote SYSID specified must also be defined for an MSNAME.

For a local transaction where SIDR is not specified, SIDR is defined to be the same value as SIDL.

The SIDR parameter is independent of the link type (CTC, MTM, TCP/IP, VTAM) specified on the TYPE= keyword of the MSPLINK macro statement.

Keyword combination rules include the following:

- FP(E) and SIDR are mutually exclusive, unless SIDL and SIDR are specified as a pair and are equal to the local system ID of this IMS.
- FP(P) and SIDR are mutually exclusive.
- MSNAME and SIDR are mutually exclusive.
- SIDR value must be defined to this IMS.

### **SPASZ**

Specifies the scratchpad area (SPA) size, in bytes, for a conversational transaction. The value can be a number from 16 and 32767.

CONV(N) and SPASZ are mutually exclusive.

### **SPATRUNC**

Specifies the scratchpad area (SPA) truncation option of a conversational transaction. This defines whether the SPA data should be truncated or preserved across a program switch to a transaction that is defined with a smaller SPA. If not specified for a conversational transaction, the value is defined to be the TRUNC parameter in DFSDCxxx.

When a conversation initially starts, and when a program is switched, the SPATRUNC option is checked and set or reset as specified. When the option is set, it remains set for the life of the conversation, or until a program switch occurs to a transaction that specifies the option is to be reset.

When a program switch occurs, the truncated data option for the new transaction is first checked, and that specification is set for the conversation and is used for the SPA inserted into the output message. If the option is not specified for the new transaction, the option currently in effect for the conversation is used.

#### **S**

IMS preserves all of the data in the SPA, even when a program switch is made to a transaction that is defined with a smaller SPA. The transaction with the smaller SPA does not see the truncated data, but when the transaction switches to a transaction with a larger SPA, the truncated data is used.

#### **R**

The truncated data is not preserved.

Keyword combination rules include the following:

- CONV(N) and SPATRUNC are mutually exclusive.

### **TRANSTAT**

Specifies whether transaction level statistics should be logged for message driven programs. If Y is specified, transaction level statistics are written to the log in a X'56FA' log record.

#### **N**

Transaction level statistics should not be logged.

#### **Y**

Transaction level statistics should be logged.

The TRANSTAT keyword is optional. If a value is not specified for the TRANSTAT keyword, the system default is used. The system default for the transaction level statistics parameter is set with the TRANSTAT parameter in the DFSDFxxx PROCLIB member. If a value is not specified for the TRANSTAT parameter, the system default is set to N. The TRANSTAT keyword on the **CREATE TRAN** or **CREATE TRANDESC** command gives the user the ability to override the system default when creating a transaction or transaction descriptor.

### **WFI**

Specifies the wait-for input option. This attribute does not apply to Fast Path transactions, which always behave as wait-for-input transactions.

#### **N**

This is not a wait-for-input transaction. This is the default.

#### **Y**

This is a wait-for-input transaction. A message processing or batch processing application program that processes WFI transactions is scheduled and invoked normally. If the transaction to be processed is defined as WFI, the program is allowed to remain in main storage after it has processed the available input messages. The QC status code (no more messages) is returned to the program if the processing limit count (PLCT) is reached; a command is entered to change the status of the scheduled transaction, database, program, or class; commands relating to the databases used by the transaction are entered, or IMS is terminated with a checkpoint shutdown.

CMTMODE(MULT) and WFI(Y) are mutually exclusive.

## **Usage notes**

Descriptors exist for the life of the IMS unless they are deleted using a **DELETE** command. Descriptors are recoverable across an IMS warm start or emergency restart. Descriptors are lost if IMS is cold started, unless cold start imports definitions that were exported while IMS was up.

The **CREATE TRANDESC** command is similar to local online change (using a **/MODIFY** command) or global online change (using an **INITIATE OLC** command) for transaction resources in the MODBLKS data set, except that transactions are added dynamically.

The **CREATE TRANDESC** command can be issued only through the Operations Manager API. These commands apply to DB/DC and DCCTL systems.

These commands are not valid on the XRF alternate or FDBR region. The **CREATE** command is not valid if online change for MODBLKS is enabled (DFSDFxxx or DFSCGxxx defined with MODBLKS=OLC or MODBLKS not defined).

## Output fields

The following table shows the **CREATE TRANDESC** output fields. The columns in the table are as follows:

### Short label

Contains the short label generated in the XML output.

### Keyword

Identifies keyword on the command that caused the field to be generated. N/A appears for output fields that are always returned. The value *error* appears for output fields that are returned only in case of an error.

### Meaning

Provides a brief description of the output field.

*Table 172. Output fields for the CREATE TRANDESC command*

| Short label | Keyword      | Meaning  |
|-------------|--------------|--|
| CC          | N/A          | Completion code.   |
| CCTXT       | <i>error</i> | Completion code text that briefly explains the meaning of the non-zero completion code.  |
| DESC        | TRANDESC     | Transaction descriptor name.   |
| MBR         | N/A          | IMSplex member that built the output line.   |
| OLDDEF      | TRANDESC     | Old default descriptor name, if this descriptor is made the default by specifying DEFAULT(Y). The old default descriptor is no longer the default. |

## Return, reason, and completion codes

The following table includes the return and reason codes and a brief explanation of the codes. The return or reason code returned for the command might also indicate an error from a CSL request.

*Table 173. Return and reason codes for the CREATE TRANDESC command*

| Return code | Reason code | Meaning  |
|-------------|-------------|--|
| X'00000000' | X'00000000' | Command completed successfully. The command output contains a line for each descriptor, accompanied by its completion code. See the completion code table for details. |
| X'00000008' | X'0000204C' | The class value is invalid.  |
| X'00000008' | X'00002050' | The current priority CPRI value is invalid.  |
| X'00000008' | X'00002054' | The limit count LCT value is invalid.  |
| X'00000008' | X'00002058' | The limit priority LPRI is invalid.  |
| X'00000008' | X'0000205C' | The maximum region MAXRGN is invalid.  |
| X'00000008' | X'00002060' | The normal priority NPRI value is invalid.   |

Table 173. Return and reason codes for the CREATE TRANDESC command (continued)

| Return code | Reason code | Meaning  |
|-------------|-------------|--|
| X'00000008' | X'00002064' | The parallel limit count PARLIM value is invalid.  |
| X'00000008' | X'00002068' | The processing limit count PLCT is invalid.  |
| X'00000008' | X'0000206C' | The segment number SEGNO value is invalid.   |
| X'00000008' | X'00002070' | The segment size SEGSZ value is invalid.   |
| X'00000008' | X'00002100' | CMTMODE(MULT) mutually exclusive with WFI(Y). Either both keywords were explicitly specified, or one keyword was explicitly specified and the other attribute was obtained from the model.   |
| X'00000008' | X'00002101' | CONV(Y) mutually exclusive with CMTMODE(MULT). Either both keywords were explicitly specified, or one keyword was explicitly specified and the other attribute was obtained from the model.  |
| X'00000008' | X'00002102' | CONV(Y) mutually exclusive with INQ(Y). Either both keywords were explicitly specified, or one keyword was explicitly specified and the other attribute was obtained from the model.   |
| X'00000008' | X'00002103' | CONV(N) mutually exclusive with SPASZ>0 or SPATRUNC. Either both keywords were explicitly specified, or one keyword was explicitly specified and the other attribute was obtained from the model.  |
| X'00000008' | X'00002104' | CONV(Y) mutually exclusive with RECOVER(N). Either both keywords were explicitly specified, or one keyword was explicitly specified and the other attribute was obtained from the model.   |
| X'00000008' | X'00002105' | CONV(Y) requires SPASZ and SPATRUNC. Either SPASZ was not explicitly specified or defined in the model, or SPATRUNC was not explicitly specified or defined in the model. CONV(Y) was either explicitly specified or defined in the model. |
| X'00000008' | X'00002108' | Invalid EDITRTN name. EDITRTN was specified explicitly or obtained from the model.   |
| X'00000008' | X'00002109' | Maximum 255 edit routines exceeded. EDITRTN was specified explicitly or obtained from the model.   |
| X'00000008' | X'0000210C' | FP(E) mutually exclusive with EDITRTN. Either both keywords were explicitly specified, or one keyword was explicitly specified and the other attribute was obtained from the model.  |
| X'00000008' | X'0000210E' | FP(E) or FP(P) mutually exclusive with MSC keyword, either MSNAME or SIDR and SIDL. Either both keywords were explicitly specified, or one keyword was explicitly specified and the other attribute was obtained from the model.           |
| X'00000008' | X'0000210F' | FP(E) or FP(P) mutually exclusive with MSGTYPE(MULTSEG). Either both keywords were explicitly specified, or one keyword was explicitly specified and the other attribute was obtained from the model.                                      |



Table 173. Return and reason codes for the CREATE TRANDESC command (continued)

| Return code | Reason code | Meaning  |
|-------------|-------------|--|
| X'00000008' | X'00002110' | FP(N) mutually exclusive with EMHBSZ > 0. Either both keywords were explicitly specified, or one keyword was explicitly specified and the other attribute was obtained from the model.                           |
| X'00000008' | X'00002111' | FP(E) or FP(P) mutually exclusive with RECOVER(N). Either both keywords were explicitly specified, or one keyword was explicitly specified and the other attribute was obtained from the model.                  |
| X'00000008' | X'00002112' | FP(E) or FP(P) mutually exclusive with RESP(N). Either both keywords were explicitly specified, or one keyword was explicitly specified and the other attribute was obtained from the model.                     |
| X'00000008' | X'00002116' | INQ(N) mutually exclusive with RECOVER(N). Either both keywords were explicitly specified, or one keyword was explicitly specified and the other attribute was obtained from the model.                          |
| X'00000008' | X'00002117' | Invalid LIKE descriptor name.  |
| X'00000008' | X'00002118' | Invalid LIKE resource name.  |
| X'00000008' | X'00002119' | MSC keyword MSNAME or SIDR and SIDL are mutually exclusive with application program defined as Fast Path exclusive (FP(E)) associated with this transaction.   |
| X'00000008' | X'0000211A' | Invalid MSNAME name.   |
| X'00000008' | X'0000211B' | MSNAME mutually exclusive with SIDR and SIDL.  |
| X'00000008' | X'0000211D' | MAXRGN>0 mutually exclusive with PARLIM(65535). Either both keywords were explicitly specified, or one keyword was explicitly specified and the other attribute was obtained from the model.                     |
| X'00000008' | X'0000211E' | MAXRGN>0 mutually exclusive with SERIAL(Y). Either keywords were explicitly specified, or one keyword was explicitly specified and the other attribute was obtained from the model.                              |
| X'00000008' | X'00002120' | PGM() definition missing. PGM must be defined for local transactions either explicitly or in the model.  |
| X'00000008' | X'00002121' | PARLIM value mutually exclusive with SERIAL(Y). Either both keywords were explicitly specified, or one keyword was explicitly specified and the other attribute was obtained from the model.                     |
| X'00000008' | X'00002123' | Invalid PGM name. PGM was specified explicitly, or obtained from the model. If the IMS-defined descriptor DFSDSTR1 was used, the command failed because DFSDSTR1 defines no program name.                        |
| X'00000008' | X'00002125' | REMOTE(Y) requires MSC keyword MSNAME or SIDR and SIDL. Either MSNAME or SIDR and SIDL were not explicitly specified or defined in the model. REMOTE(Y) was either explicitly specified or defined in the model. |

Table 173. Return and reason codes for the CREATE TRANDESC command (continued)

| Return code | Reason code | Meaning  |
|-------------|-------------|--|
| X'00000008' | X'00002126' | Invalid SIDL value.  |
| X'00000008' | X'00002127' | SIDL/SIDR must be specified as a pair. Either SIDL was specified alone or SIDR was specified alone.  |
| X'00000008' | X'00002128' | Invalid SIDR value.  |
| X'00000008' | X'00002133' | Multiple name parameters were specified with DEFAULT(Y). Only one descriptor can be the default at one time.   |
| X'0000000C' | X'00003000' | Command was successful for some descriptors but failed for others. The command output contains a line for each descriptor, accompanied by its completion code. See the completion code table for details.  |
| X'0000000C' | X'00003004' | Command was not successful for any of the descriptors. The command output contains a line for each descriptor, accompanied by its completion code. See the completion code table for details.  |
| X'00000010' | X'0000400C' | Command is not valid on the XRF alternate.   |
| X'00000010' | X'00004024' | No Fast Path defined, so FP(E), FP(P), or EMHBSZ > 0 is invalid.   |
| X'00000010' | X'00004120' | Online change phase is in progress.  |
| X'00000010' | X'00004204' | Model is quiesced. Cannot quiesce model.   |
| X'00000010' | X'00004300' | Command is not allowed because online change for MODBLKS is enabled (DFSDFxxx or DFSCGxxx defined with MODBLKS=OLC, or MODBLKS not defined).   |
| X'00000010' | X'00004310' | Storage could not be obtained for the Transaction Input edit routine table. A cold start is required to fix this error.  |
| X'00000010' | X'00004314' | The Transaction Input edit routine could not be loaded.  |
| X'00000010' | X'00004318' | A new Transaction Input edit routine could not be added. The maximum of 255 routines has already been reached.   |
| X'00000014' | X'00005004' | DFSOCMD response buffer could not be obtained.   |
| X'00000014' | X'00005008' | DFSPPOOL storage could not be obtained.  |
| X'00000014' | X'0000500C' | AWE could not be obtained.   |
| X'00000014' | X'00005010' | Unable to obtain latch.  |
| X'00000014' | X'00005114' | Resource or descriptor that is specified as a model is in the process of being imported from the change list in the IMSRSC repository or was not imported successfully from the change list at the end of IMS restart. This resource or descriptor cannot be referenced as a model on a <b>CREATE</b> command until it is successfully imported from the repository. |

Errors unique to the processing of this command are returned as completion codes. The following table includes an explanation of the completion codes.

Table 174. Completion codes for the CREATE TRANDESC command

| Completion code | Completion code text             | Meaning  |
|-----------------|----------------------------------|--|
| 0               |                                  | Command completed successfully for transaction descriptor.   |
| 11              | RESOURCE ALREADY EXISTS          | Transaction descriptor already exists.   |
| 17              | ANOTHER CMD IN PROGRESS          | Another command (such as <b>DELETE PGM</b> or <b>UPDATE PGM</b> ) is in progress for the program referenced by this transaction.             |
| 36              | FP=E/FP=N PGM CONFLICT           | Transaction to be created as Fast Path exclusive FP(E) conflicts with program already defined as non-Fast Path FP(N).                        |
| 3E              | FP=N/FP=E PGM CONFLICT           | Transaction to be created as non-Fast Path FP(N) conflicts with program already defined as Fast Path exclusive FP(E).                        |
| 3F              | FP=P/BMPTYPE=Y CONFLICT          | Transaction to be created as Fast Path potential FP(P) conflicts with the program defined as batch BMPTYPE(Y).                               |
| 5F              | INVALID CHARACTERS IN NAME       | Name is invalid because it contains an invalid character.  |
| 61              | DFSBCB STORAGE ERROR             | Request to get BCB storage for SMB control block failed.   |
| 8A              | WILDCARD PARAMETER NOT SUPPORTED | The <b>CREATE</b> command does not support wildcard parameters. You must explicitly specify the names of the descriptors you want to create. |
| 93              | RESERVED NAME                    | Name is reserved. For example, name starts with DFS (except for DFSSAMxx or DFSIVPxx), or is an IMS reserved name such as BASICEDT or WTOR.  |

### Examples

The following are examples of the **CREATE TRANDESC** command:

#### Example 1 for CREATE TRANDESC command

TSO SPOC input:

```
CRE TRANDESC NAME(CONVDESC) LIKE(RSC(CDEBTRNA))
SET(CONV(Y),SPASZ(128),SPATRUNC(R),PGM(DFSSAM04),DEFAULT(Y))
```

TSO SPOC output:

```
DescName MbrName      CC OldDefault
CONVDESC IMS1         0 DFSDSTR1
```

OM API input:

```
CMD(CRE TRANDESC NAME(CONVDESC) LIKE(RSC(CDEBTRNA))
SET(CONV(Y),SPASZ(128),SPATRUNC(R),PGM(DFSSAM04),DEFAULT(Y)))
```

## OM API output:

```
<imsout>
<ctl>
<omname>OM10M </omname>
<omvsn>1.3.0</omvsn>
<xmlvsn>20 </xmlvsn>
<statime>2006.307 18:52:58.805900</statime>
<stotime>2006.307 18:52:58.806677</stotime>
<staseq>BFA6C8765828C44A</staseq>
<stoseq>BFA6C8765859584A</stoseq>
<rqsttkn1>USRT011 10105258</rqsttkn1>
<rc>00000000</rc>
<rsn>00000000</rsn>
</ctl>
<cmd>
<master>IMS1 </master>
<userid>USRT011 </userid>
<verb>CRE </verb>
<kwd>TRANDESC </kwd>
<input>CRE TRANDESC NAME(CONVDESC) LIKE(RSC(CDEBTRNA))
SET(CONV(Y),SPASZ(128),SPATRUNC(R),PGM(DFSSAM04),DEFAULT(Y)) </input>
</cmd>
<cmdrsphdr>
<hdr slbl="DESC" llbl="DescName" scope="LCL" sort="a" key="1"
scroll="no" len="8" dtype="CHAR" align="left" />
<hdr slbl="MBR" llbl="MbrName" scope="LCL" sort="a" key="2" scroll="no"
len="8" dtype="CHAR" align="left" />
<hdr slbl="CC" llbl="CC" scope="LCL" sort="n" key="0" scroll="yes"
len="4" dtype="INT" align="right" skipb="no" />
<hdr slbl="CCTXT" llbl="CCText" scope="LCL" sort="n" key="0"
scroll="yes" len="*" dtype="CHAR" skipb="yes" align="left" />
<hdr slbl="OLDDEF" llbl="OldDefault" scope="LCL" sort="a" key="2"
scroll="no" len="8" dtype="CHAR" align="left" />
</cmdrsphdr>
<cmdrspdata>
<rsp>DESC(CONVDESC) MBR(IMS1) CC( 0) OLDDEF(DFSDSTR1) </rsp>
</cmdrspdata>
</imsout>
```

**Explanation:** A **CREATE TRANDESC** command is issued to create a transaction descriptor for conversational transactions. Descriptor CONVDESC takes the same attributes as transaction CDEBTRNA except for the conversation attribute, SPA size, SPA truncate option, and program name. It is also made the default descriptor, so that if no LIKE keyword is specified on a **CREATE TRAN** or **CREATE TRANDESC** command, the transaction or descriptor is defined with the attributes in descriptor CONVDESC.

### Related concepts

[How to interpret CSL request return and reason codes \(System Programming APIs\)](#)

### Related reference

[“Command keywords and their synonyms” on page 59](#)

All IMS command keywords and their synonyms, as well as keywords supported by the OM API, are listed. The list covers command keywords for the OM command processing clients such as IMS, ODBM, IMSCON, and RM.

[Commit Verify exit routine \(Exit Routines\)](#)

## Chapter 20. /DBDUMP command

Use the **/DBDUMP** command to prevent transactions or programs from updating DL/I databases. It also can be used to dump all MSDBs to the MSDB dump data set. **/DBDUMP** does not apply to DEDBs.

Subsections:

- “Environment” on page 329
- “Syntax” on page 329
- “Keywords” on page 329
- “Usage notes” on page 331
- “Equivalent IMS type-2 commands” on page 332
- “Examples” on page 332

### Environment

The following table lists the environments (DB/DC, DBCTL, and DCCTL) in which you can use the command and keywords.

Table 175. Valid environments for the /DBDUMP command and keywords

| Command / Keywords | DB/DC | DBCTL | DCCTL |
|--------------------|-------|-------|-------|
| <b>/DBDUMP</b>     | X     | X     |       |
| DB                 | X     | X     |       |
| GLOBAL             | X     | X     |       |
| LOCAL              | X     | X     |       |
| NOFEOV             | X     | X     |       |
| NOPFA              | X     | X     |       |

### Syntax

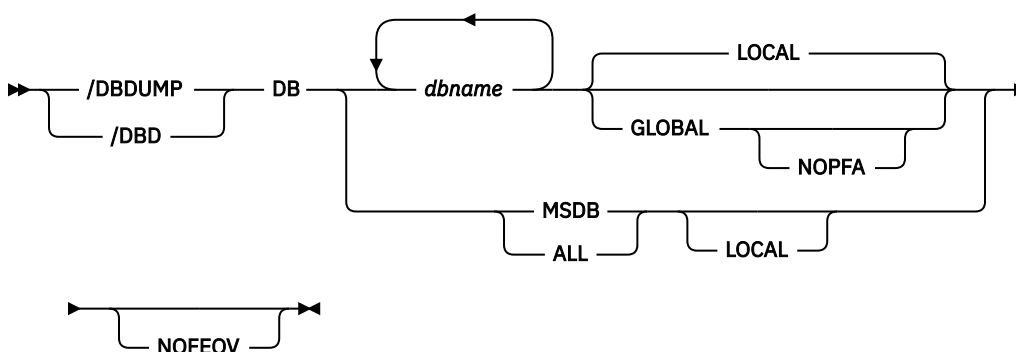

### Keywords

The following keywords are valid for the **/DBDUMP** command:

## DB

Specifies the databases to which the **/DBDUMP** command applies. When the **/DBDUMP** command is entered, the message processing regions using the specified databases are terminated at the conclusion of processing their current transactions, in preparation to close the database and enable it to be opened for input only.

If a DL/I database specified in the command is being used by a batch message processing region, an error message is returned to the master terminal. When this message is issued, the command is ignored for the database named in the message; processing continues for the other databases specified in the command. The master terminal operator must wait until the batch message processing concludes processing before reentering the command.

As the message processing regions terminate programs, the data sets of the named databases in the command are closed. The IMS log switches to the next OLDS. This switch to the next OLDS is marked as a recovery point for log archiving purposes. IMS issues a simple checkpoint. The scheduling of transactions is then resumed, although no transactions will be allowed to update the specified databases. Programs with update intent will be scheduled, but update calls to the database will result in a 3303 pseudoabend or a BA status if the INIT call was issued.

**/DBDUMP** can be used to dump all the MSDBs to the MSDB dump data set by specifying the reserved parameter MSDB with the DB keyword when entering the **/DBDUMP DB** command or by entering the **/DBDUMP DB ALL** command. The MSDBs dumped to the MSDB dump data set can be used as input to the MSDB Dump Recovery utility. A specific MSDB cannot be a parameter of the DB keyword.

The **/START DB** command resets the effect of the **/DBDUMP** command. The **/START** command is not required for MSDBs, because the data for these databases resides in processor storage, and the databases are never closed.

For DBCTL, when CCTL schedules a PSB, the DBCTL thread SCHED request defines the thread as LONG or SHORT. If the database is currently scheduled to a LONG thread, the command is rejected; otherwise, the thread is allowed to "complete" before the database is acted upon. This results in either a commit point or transaction termination.

## GLOBAL

Applies when an IRLM is active and specifies that the command applies to all online subsystems sharing the database. The **/DBDUMP** command with the GLOBAL keyword puts the database in read status and prevents transactions from updating the database in all online subsystems that share the database.

The **/DBDUMP GLOBAL** command is processed by the IMS system where the command was initiated. The systems will process the command locally and then request IRLM NOTIFY to route and process the command on sharing IMS systems.

If global database status is maintained, the global status maintained in RM is also updated. The global status is set to STOUPDS.

If the command is entered from OM API, the global status is updated by the command master IMS. If the command is not entered from OM API, the IMS that initiated the GLOBAL command updates the global status in RM.

If global status in RM is successfully updated, message DFS0988I for RSRCTYPE=DB is issued. If global status is not successfully updated, message DFS3308I is issued, indicating RM failure, and no command response lines are generated. Any RM error is traced to the OCMD trace table. Users can issue a **QRY DB STATUS(GLOBAL)** command to set the global status of the resources in RM.

The X'4C' log record for databases is updated to include both the global status and global command time stamp.

The GLOBAL keyword is mutually exclusive with the ALL parameter or the MSDB parameter and causes the command to be rejected if both parameters are specified. The GLOBAL keyword requires that IRLM be active and will cause the command to be rejected if IRLM is not active.

If the command with GLOBAL is entered from OM API, the command master IMS becomes the initiating system. The command IMS will process the command locally first and then make DBRC calls

to update the RECON with GLOBAL status. It will also request IRLM NOTIFY to route and process the command on sharing IMS systems.

Messages produced on the NOTIFIED systems will appear only on the system console and will not be routed back to the OM API which originally entered the command.

If the command is routed to multiple IMS systems, the non-master IMS systems to which OM routes the command, will reject the command with the return and reason codes shown in the following table.

*Table 176. Return and reason code for the GLOBAL keyword issued from the OM API*

| Return code | Reason code | Meaning  |
|-------------|-------------|--|
| X'00000004' | X'00001000' | The command contained the GLOBAL keyword and was routed to more than one IMS system in the IMSPLEX. The non-master IMS systems will reject this command when OM routes the command to them. The master IMS system will process this command and use IRLM NOTIFY to route and process the command on the non-master IMS systems. See the discussion under the GLOBAL keyword. |

### LOCAL

Specifies that the command only applies to the subsystem in which the command is entered. This command does not affect any other subsystem sharing the database. The LOCAL keyword can be used to restrict concurrent updates. LOCAL is the default.

### NOFEOV

Specifies that there is no forced end of volume, so that the IMS log does not switch to the next OLDS. If NOFEOV is specified without the MSDB keyword, a simple checkpoint is not taken.

### NOPFA

Specifies that the call to DBRC that sets the Read Only flag in the RECON data set for the database or partition is to be skipped. You can use this keyword when you need to authorize the database for update after the command has been processed. By using this keyword, DBRC does not prevent authorizations for update for the database or partition. NOPFA can be specified only with the GLOBAL keyword.

## Usage notes

The **/DBDUMP** command can be used on HALDB databases.

In an IMSplex, the output of the **/DBD** command is changed when the command is entered through the OM API. In this case, the DFS058I message is not returned to OM. The command response returned to OM contains one or more of the following messages as appropriate to the database type and the command completion.

This command can be issued to an IMSplex using the Batch SPOC utility.

Full Function Database messages: DFS132, DFS160, DFS216, DFS0488I, DFS1407, DFS2026, DFS3318I, DFS3320I, DFS3321I, DFS3325I, DFS3462I, DFS3463I, DFS3466I

When you enter this command, the database name can be an existing non-HALDB, a HALDB master, or a HALDB partition. A command against a HALDB partition operates exactly like a command against a non-HALDB with the exception of the **/START DATABASE** and the **UPDATE DB START (ACCESS)** command. A HALDB partition is not allocated during the command unless it was previously authorized but not allocated, the OPEN keyword was specified, or the partition has EEQEs. The partition is allocated at first reference.

For HALDB databases, IMS tracks partition statuses and master database statuses separately. For example, a partition can be stopped, but its master database can be started. Alternatively, the partition can be started, but its master database can be stopped. Before opening, authorizing, or scheduling a

partition, IMS always examines the status of the partition and the master database. If either the partition or the master database has a status that prevents the action, IMS does not perform the action.

Each partition has the access limitations of both itself and its master database. For example, if the master database has an access intent of read (READ) and one of its partitions has an access intent of update (UPD), the partition cannot be updated. Alternatively, if the master database has an access intent of update (UPD) and one of its partitions has an access intent of read (READ), the partition cannot be updated. Similar considerations apply to other statuses that affect access limitations, such as being stopped or locked.

**Exception:** If the HALDB master database has update access (UPD), the partitions can have an access intent of exclusive (EXCL), exceeding the access of the master.

Commands that are issued with a partition name affect only the status of the partition. Commands that are issued against the master database affect only the status of the master database. Therefore, a start of a master database does not update the status of its partitions. If the partitions are stopped, they remain stopped. When a HALDB partition is explicitly stopped, it must be explicitly started again. The type-1 commands with the keyword ALL, type-2 commands with NAME(\*), and commands against a HALDB master do not change the STOPPED (shown as STOACC, STOSCHD, or STOU PDS on QUERY DB) and LOCKED indicators in each HALDB partition.

When the command target is a HALDB master, processing acts on all HALDB partitions. For example, if the IMS command is UPDATE DB STOP(ACCESS) on the HALDB master, all of the HALDB partitions are closed, deallocated, and deauthorized. However, the stopped status is only set in the master database. If a QUERY DB command is issued, only the HALDB master displays a status of STOACC (each HALDB partition does not display STOACC unless it was itself stopped). If a UPDATE DB STOP(ACCESS) command was issued against a HALDB master, the display output of a /DISPLAY DB command shows the HALDB master (as STOPPED), but does not display the status of the partitions.

**Restrictions:**

- The **/DBDUMP DB** command cannot be processed against a HALDB partition on an IMS system while HALDB Online Reorganization (OLR) is running against that partition on the same IMS system.
- The **/DBDUMP DB** command cannot be issued against a HALDB master while OLR is reorganizing any of its partitions.
- While the database is being quiesced, this command cannot be processed successfully.

The **/DBDUMP DB** command is not allowed for a database that is marked bad with the NOTINIT-48-REPOCHGLIST reason code because the IMS change list processing is not complete for the database or the change list processing failed.

**Equivalent IMS type-2 commands**

The following table shows variations of the **/DBDUMP** command and the IMS type-2 commands that perform similar functions.

*Table 177. Type-2 equivalents for the /DBDUMP command*

| <b>Task</b>                  | <b>/DBDUMP command</b>   | <b>Similar IMS type-2 command</b>  |
|------------------------------|--------------------------|--|
| Stops updates to a database. | /DBDUMP DB <i>dbname</i> | UPDATE DB NAME( <i>dbname</i> )<br>STOP(UPDATES) OPTION(FEOV) <sup>1</sup> |

<sup>1</sup> This command does not automatically issue checkpoints unless OPTION(FEOV) is specified.

**Examples**

The following are examples of the **/DBDUMP** command:

**Example 1 for /DBDUMP command**



Entry ET:

```
/DBDUMP DATABASE PAYROLL
```

Response ET:

```
DFS058I (time stamp) DBDUMP COMMAND IN PROGRESS
```

Explanation: Currently executing application programs are being terminated. When the termination completes, the databases are stopped for update and the output log is switched to the next OLDS.

Response ET:

```
DFS0488I DBD COMMAND COMPLETED.  
          DBN=PAYROLL RC=0  
DFS3257I ONLINE LOG NOW SWITCHED FROM DFSOLP( ) TO DFSOLP( )  
DFS994I *CHKPT 82080/111213**SIMPLE*
```

Explanation: The new OLDS is used to record a simple checkpoint at 111213 (time) on 82080 (Julian date). The checkpoint number is 82080/111213. All **/DBDUMP** command functions are complete. The **/START DATABASE** command must be used to start the database after the dump job completes.

### ***Example 2 for /DBDUMP command***

Entry ET:

```
/DBDUMP DATABASE MSDB
```

Response ET:

```
DFS058I (time stamp) DBDUMP COMMAND IN PROGRESS
```

Explanation: All MSDBs are dumped to the MSDB dump data set because MSDB was specified as the parameter of the database keyword.

Response ET:

```
DFS994I CHKPT 82069/123624**SIMPLE*
```

Explanation: A simple checkpoint is recorded on the new system log at 123624 (time) on 82069 (Julian date). The checkpoint number is 82069/123624. All MSDBs are dumped.

### **Related concepts**

[Maintaining global information for databases, DEDB areas, and transactions \(System Administration\)](#)

### **Related reference**

[UPDATE DB command \(Commands\)](#)



---

## Chapter 21. /DBRECOVERY command

Use the **/DBRECOVERY** command to prevent transactions or programs from accessing DL/I databases, DEDBs, or DEDB areas.

Subsections:

- [“Environment” on page 335](#)
- [“Syntax” on page 335](#)
- [“Keywords” on page 336](#)
- [“Usage notes” on page 338](#)
- [“Equivalent IMS type-2 commands” on page 340](#)
- [“Examples” on page 340](#)

### Environment

The following table lists the environments (DB/DC, DBCTL, and DCCTL) in which you can use the command and keywords.

*Table 178. Valid environments for the /DBRECOVERY command and keywords*

| <b>Command / Keywords</b> | <b>DB/DC</b> | <b>DBCTL</b> | <b>DCCTL</b> |
|---------------------------|--------------|--------------|--------------|
| <b>/DBRECOVERY</b>        | X            | X            |              |
| AREA                      | X            | X            |              |
| DB                        | X            | X            |              |
| DATAGRP                   | X            | X            |              |
| GLOBAL                    | X            | X            |              |
| LOCAL                     | X            | X            |              |
| NOFEOV                    | X            | X            |              |
| NOPFA                     | X            | X            |              |

### Syntax

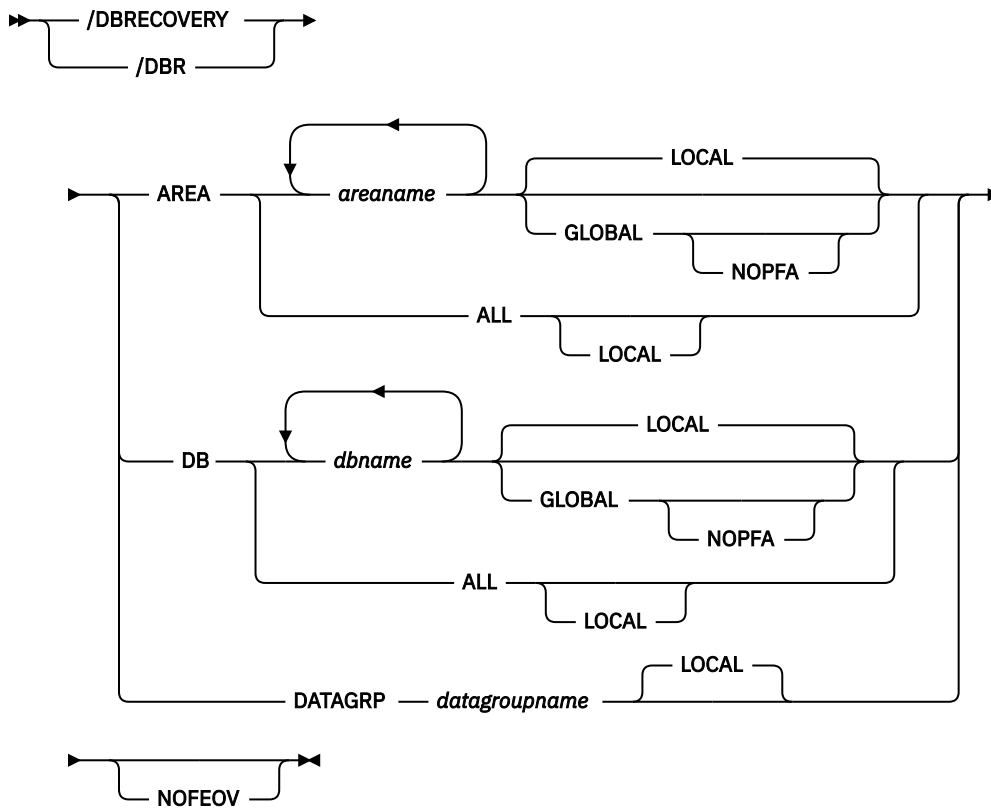

## Keywords

The following keywords are valid for the `/DBRECOVERY` command:

### AREA

Specifies the DEDB areas (but not DEDBs) to be processed by the `/DBRECOVERY` command. The `/DBRECOVERY AREA` command stops the accessing and updating of specified DEDB areas and closes them.

The `/START AREA` command can be used to reopen and reallocate the areas closed by `/DBRECOVERY AREA` command.

The `/DBRECOVERY` command for Fast Path Virtual Storage Option (VSO) areas in a z/OS data space removes the areas from the data space and forces updates to be written back to DASD.

While the database is being quiesced, this command cannot be processed successfully.

### DATAGRP

Specifies a group of DL/I databases and Fast Path DEDBs to be processed by the `/DBRECOVERY` command. Use the `INIT.DBDSGRP` command with the `GRPNAME` and `DBGRP` keywords to define the data group in the RECON data set.

**Recommendation:** Although you can use DBDS groups as well as database groups for this command, you should use database groups whenever possible to eliminate the overhead of converting the DBDS group to a database group.

### DB

Specifies the DL/I databases and Fast Path DEDBs (and inclusive areas) to be processed by the `/DBRECOVERY` command. MSDBs cannot be specified with `/DBRECOVERY`. The `/DBRECOVERY DB` command allows scheduling of transactions or programs that use the database to continue after successful completion of the command. However, calls to DEDB databases will receive an FH status code. If the application program is prepared to accept status codes regarding data unavailability

through the INIT STATUS GROUPA or GROUPB call, calls to DL/I databases will result in either a 3303 pseudoabend, a BA, or BB status code.

When the **/DBRECOVERY DB** command is entered, the data sets of the databases named in the command are closed. The **/DBRECOVERY DB** command dynamically deallocates the IMS databases. For DEDBs, the randomizer is unloaded and removed from storage. You can use the **UPD DB STOP (ACCESS) OPTION (NORAND)** command to prevent the randomizer from being unloaded.

If a DL/I database is in use by a batch message processing region when the **/DBRECOVERY** command is issued, a DFS0565I message is returned to the master terminal, the command is ignored for the database named in the message, and processing continues for any other databases specified in the command. The master terminal operator must wait until the BMP ends before reissuing the **/DBRECOVERY** command to close the databases named in any DFS0565I messages. DEDB databases will accept the **/DBRECOVERY** command while actively being used by a batch message processing region. However, all further calls to the database will receive an FH status code.

The region identified in the DFS0565I message can also be an MPP region. The error message can be issued in order to break a potential deadlock condition between Online Change, a **/DBR**, or **/STA** command against a database being used by the MPP, and an application running in the MPP issuing an ICMD or CMD call.

The **/START DB** command is used to reallocate the databases closed by the **/DBRECOVERY DB** command except for HALDB partitions. A HALDB partition can be reallocated if the partition has EEQEs, the partition was previously authorized but not allocated, or the OPEN keyword on the **/START DB** command was used. HALDB partitions are allocated at first reference. For DEDBs, a **/START DB** command also causes a reload of the randomizer.

For DBCTL, when CCTL schedules a PSB, the DBCTL thread SCHED request defines the thread as LONG or SHORT. If the database is currently scheduled to a LONG thread, the command is rejected; otherwise, the thread is allowed to complete its current commit cycle before the database is acted upon. This results in either a commit point or transaction termination.

While the database is being quiesced, this command cannot be processed successfully.

The **/DBRECOVERY DB** command is not allowed for a database that is marked bad with the NOTINIT-48-REPOCHGLIST reason code because the IMS change list processing is not complete for the database or the change list processing failed.

## GLOBAL

Applies when the database is registered to DBRC and specifies that the command applies to all sharing online subsystems. You can use the **/DBRECOVERY GLOBAL** command to close the database so that it can be taken offline when this command successfully completes in all online subsystems. If the database is registered in the RECON data set, the prohibit authorization flag will be set (PROHIBIT AUTH = ON), and DBRC will prevent any further authorization of the database. This is equivalent to the **CHANGE .DB DBD(XXX) NOAUTH DBRC** command.

The **/DBRECOVERY GLOBAL** command is processed by the IMS system where the command was initiated. This system will process the command locally and then request IRLM NOTIFY to route and process the command on sharing IMS systems.

If global DB or AREA status is maintained, the global status maintained in RM is also updated. The global status is set to STOACC.

If the command is entered from OM API, the global status is updated by the command master IMS. If the command is not entered from OM API, the IMS that initiated the GLOBAL command updates the global status in RM.

If global status in RM is successfully updated, message DFS0988I for RSRCTYPE=DB is issued. If global status is not successfully updated, message DFS3308I is issued, indicating RM failure, and no command response lines are generated. Any RM error is traced to the OCMD trace table. Users can issue a QRY DB STATUS(GLOBAL) or QUERY AREA STATUS(GLOBAL) to obtain the global status of the resources in RM.

The X'4C' log record for databases is updated to include both global status and global command time stamp. A new log record for DEDB areas, X'594C', includes both global status and global command time stamp.

The GLOBAL keyword and the ALL parameter are mutually exclusive. The **/DBRECOVERY** command will be rejected if both GLOBAL and ALL are specified. The IRLM must be active when the GLOBAL keyword is used. If IRLM is not active, the command is rejected.

If the command with GLOBAL is entered from OM API, the command master IMS becomes the initiating system. The command IMS will process the command locally first and then make DBRC calls to update the RECON with GLOBAL status. It will also request IRLM NOTIFY to route and process the command on sharing IMS systems.

Messages produced on the NOTIFIED systems will appear only on the system console and will not be routed back to the OM API that originally entered the command.

If the command is routed to multiple IMS systems, the non-master IMS systems to which OM routes the command, will reject the command with the return and reason codes shown in the following table.

*Table 179. Return and reason code for GLOBAL keyword issued from the OM API*

| Return code | Reason code | Meaning  |
|-------------|-------------|--|
| X'00000004' | X'00001000' | The command contained the GLOBAL keyword and was routed to more than one IMS system in the IMSplex. The non-master IMS systems will reject this command when OM routes the command to them. The master IMS system will process this command and use IRLM NOTIFY to route and process the command on the non-master IMS systems. See the discussion under the GLOBAL keyword. |

**Restriction:** When the GLOBAL keyword is specified, the command is performed for the named database only. If the command is to be performed for a HIDAM database and its index, both must be named.

The GLOBAL keyword cannot be combined with the DATAGRP keyword.

#### **LOCAL**

Specifies that the command applies only to the subsystem in which the command is entered. This command does not affect any other subsystem sharing the database or area. Use the LOCAL keyword to increase usability for the other system sharing the database or area. LOCAL is the default.

#### **NOFEOV**

Specifies that there is no forced end of volume, so that the log does not switch to the next OLDS and simple checkpoint is not taken.

#### **NOPFA**

Specifies to skip the call to DBRC that sets the Prohibit Authorization flag in the RECON data set for the database or area. You can use this keyword when you need to authorize the database for use after it is offline, for example, for offline utilities. By using this keyword, DBRC does not prevent further authorizations for the database or area.

NOPFA can be specified only with the GLOBAL keyword.

### **Usage notes**

The **/DBRECOVERY** command can be used on HALDB databases.

Use of the ALL parameter indicates that the command applies to all databases, even those not opened.

The **/DBRECOVERY** command closes and deallocates the databases, and deauthorizes them with DBRC. Once the database or area referenced by **/DBRECOVERY** is closed, the IMS log switches to the next OLDS

(unless you specify the NOFEOV keyword). This switch to the next OLDS is marked as a recovery point for log archiving purposes. IMS issues a simple checkpoint.

The **/DBRECOVERY** command deletes the randomizer routine from memory.

IMS databases, DEDBs, and DEDB areas closed by the master terminal operator with the **/DBRECOVERY** command can be used as input to the offline IMS Database Recovery utility. The Database Recovery utility runs in a batch region.

If the **/DBRECOVERY** command does not deallocate a data set because a VSAM data set hardware error occurred, use the **VARY nnn, OFFLINE, FORCE** command to deallocate the data set (where *nnn* is the number of the device).

In an IMSplex, the output of the **/DBR** command is different when the command is entered through the OM API. In this case, the DFS058I message is not returned to OM. The command response returned to OM contains one or more of the following messages as appropriate to the database type and the command completion.

- For **/DBR AREA** commands that specify GLOBAL, only the command master returns the asynchronous messages to OM. When a command is processed with the LOCAL keyword, all IMS systems are able to return the asynchronous messages to OM.
- Full-function database messages for **/DBR DB**: DFS132, DFS160, DFS216, DFS0488I, DFS0565I, DFS1407, DFS2026, DFS3318I, DFS3320I, DFS3321I, DFS3464I, DFS3466I.
- Fast Path database messages for **/DBR DB**: DFS140I, DFS0666I, DFS3062I, DFS3320I.
- Fast Path database messages for **/DBR AREA**: DFS140I, DFS0488I, DFS0666I, DFS1407I, DFS3060I, DFS3062I, DFS3320I, DFS3325I, DFS3342I, DFS3720I.

This command can be issued to an IMSplex using the Batch SPOC utility.

When you enter this command, the database name can be an existing non-HALDB, a HALDB master, or a HALDB partition. A command against a HALDB partition operates exactly like a command against a non-HALDB except for the **/START DB** and the **UPDATE DB START (ACCESS)** commands. A HALDB partition is not allocated during the command unless it was previously authorized but not allocated, the OPEN keyword was specified, or the partition has EEQEs. The partition is allocated at first reference.

For HALDB databases, IMS tracks partition statuses and master database statuses separately. For example, a partition can be stopped, but its master database can be started. Alternatively, the partition can be started, but its master database can be stopped. Before opening, authorizing, or scheduling a partition, IMS always examines the status of the partition and the master database. If either the partition or the master database has a status that prevents the action, IMS does not perform the action.

Each partition has the access limitations of both itself and its master database. For example, if the master database has an access intent of read (READ) and one of its partitions has an access intent of update (UPD), the partition cannot be updated. Alternatively, if the master database has an access intent of update (UPD) and one of its partitions has an access intent of read (READ), the partition cannot be updated. Similar considerations apply to other statuses that affect access limitations, such as being stopped or locked.

**Exception:** If the HALDB master database has update access (UPD), the partitions can have an access intent of exclusive (EXCL), exceeding the access of the master.

Commands that are issued with a partition name affect only the status of the partition. Commands that are issued against the master database affect only the status of the master database. Therefore, a start of a master database does not update the status of its partitions. If the partitions are stopped, they remain stopped. When a HALDB partition is explicitly stopped, it must be explicitly started again. The type-1 commands with the keyword ALL, type-2 commands with NAME(\*), and commands against a HALDB master do not change the STOPPED (shown as STOACC, STOSCHD, or STOUPDS on QUERY DB) and LOCKED indicators in each HALDB partition.

When the command target is a HALDB master, processing acts on all HALDB partitions. For example, if the IMS command is UPDATE DB STOP (ACCESS) on the HALDB master, all of the HALDB partitions are closed, deallocated, and deauthorized. However, the stopped status is only set in the master database. If a QUERY DB command is issued, only the HALDB master displays a status of STOACC (each HALDB

partition does not display STOACC unless it was itself stopped). If a UPDATE DB STOP(Access) command was issued against a HALDB master, the display output of a /DISPLAY DB command shows the HALDB master (as STOPPED), but does not display the status of the partitions.

#### Restrictions:

- The **/DBRECOVERY DB** command cannot be processed against a HALDB partition on an IMS system while HALDB Online Reorganization (OLR) is running against that partition on the same IMS system.
- The **/DBRECOVERY DB** command cannot be issued against a HALDB master while OLR is reorganizing any of its partitions.
- If the **/DBRECOVERY DB** or **UPDATE DB STOP(Access)** commands are issued for a DEDB database that has newly added areas using the DEDB Alter utility, you might need to start the DEDB database using the ACCESS option if your PSB has a PCB that is not accessing the newly added areas by their DEDB name. In this situation, issue one of the following commands:
  - **/STA DB ACCESS=UP**
  - **UPDATE DB START(Access) SET(ACCTYPE(UPD))**

The NODBR keyword can be specified in the DFSVSMxx member of the IMS PROCLIB data set to prevent a **/DBRECOVERY** command from processing against a database that has in-doubt EEQEs. NODBR does not apply to Fast Path databases.

### Equivalent IMS type-2 commands

The following table shows variations of the **/DBRECOVERY** command and the IMS type-2 commands that perform similar functions.

Table 180. Type-2 equivalents for the /DBRECOVERY command

| Task   | /DBRECOVERY command                    | Similar IMS type-2 command  |
|--|--|---|
| Stops the accessing and updating of an area.                                   | <b>/DBRECOVERY AREA areaname</b>       | UPDATE AREA NAME( <i>areaname</i> )<br>STOP(Access)                       |
| Stops the accessing and updating of all areas and databases of the data group. | <b>/DBRECOVERY DATAGRP datagrpname</b> | UPDATE DATAGRP<br>NAME( <i>datagrpname</i> )<br>STOP(Access)              |
| Stops access to the database and take it offline.                              | <b>/DBRECOVERY DB dbname</b>           | UPDATE DB NAME( <i>dbname</i> )<br>STOP(Access) OPTION(FEOV) <sup>1</sup> |

<sup>1</sup> This command does not automatically issue checkpoints unless OPTION(FEOV) is specified.

#### Examples

The following are examples of the **/DBRECOVERY** command:

##### Example 1 for /DBRECOVERY command

Entry ET:

```
/DBRECOVERY AREA ALL
```

Response ET:

```
DFS058I DBRECOVERY COMMAND IN PROGRESS
DFS0488I DBRECOVERY COMMAND COMPLETED. AREA=DBAREA0
DFS0488I DBRECOVERY COMMAND COMPLETED. AREA=DBAREA1
```

Explanation: DEDB areas are being stopped for inquiry and update, closed, and deallocated; the output log is switched to the next OLDS.



### Example 2 for /DBRECOVERY command

Entry ET:

```
/DBRECOVERY DATABASE SKILL
```

Response ET:

```
DFS058I DBRECOVERY COMMAND IN PROGRESS
DFS2500I DATABASE SKILL SUCCESSFULLY DEALLOCATED
DFS0488I DBRECOVERY COMMAND COMPLETED. DBN=SKILL RC=0
DFS3257I ONLINE LOG NOW SWITCHED FROM DFSOLP( ) TO DFSOLP( )
DFS944I *CHKPT 82123/121314**SIMPLE**
```

Explanation: The new OLDS is used to record a simple checkpoint at 121314 (time) on 82123 (Julian date). The checkpoint number is 82123/121314. All **/DBRECOVERY** command functions are complete. The Database Recovery utility can be executed after archiving. Currently executing application programs are being terminated. When the termination completes, the SKILL database is stopped for inquiry and update, closed, and deallocated; the output log is switched to the next OLDS. The **/START DATABASE** command must be used to start the database after the recovery job completes.

### Example 3 for /DBRECOVERY command

This example shows how the **/DBRECOVERY** command might look when entered from the SPOC.

TSO SPOC input:

```
DBR DB BANKATMS BANKTERM BANKLDGR BE3ORDER
```

TSO SPOC output:

```
SYS3 DFS0488I DBR COMMAND COMPLETED. DBN= BANKATMS RC=04
SYS3 DFS0488I DBR COMMAND COMPLETED. DBN= BANKTERM RC=04
SYS3 DFS0488I DBR COMMAND COMPLETED. DBN= BANKLDGR RC=04
SYS3 DFS0488I DBR COMMAND COMPLETED. DBN= BE3ORDER RC= 0
IMS3 DFS0488I DBR COMMAND COMPLETED. DBN= BANKATMS RC=04
IMS3 DFS0488I DBR COMMAND COMPLETED. DBN= BANKTERM RC=04
IMS3 DFS0488I DBR COMMAND COMPLETED. DBN= BANKLDGR RC=04
IMS3 DFS0488I DBR COMMAND COMPLETED. DBN= BE3ORDER RC= 0
```

OM API input:

```
CMD (DBR DB BANKATMS BANKTERM BANKLDGR BE3ORDER)
```

OM API output:

```
<?xml version="1.0"?>
<!DOCTYPE imsout SYSTEM "imsout.dtd">
<imsout>
<ctl>
<omname>OM10M </omname>
<omvsn>1.1.0</omvsn>
<xmlvsn>1 </xmlvsn>
<statime>2002.197 21:52:02.730359</statime>
<stotime>2002.197 21:52:03.383199</stotime>
<staseq>B7EFBE716A9770A4</staseq>
<stoseq>B7EFBE7209F9FD2F</stoseq>
<rqsttkn1>USRT005 10145202</rqsttkn1>
<rc>0200000C</rc>
<rsn>00003008</rsn>
</ctl>
<cmderr>
<mbr name="SYS3 ">
<typ>IMS </typ>
<styp>DBDC </styp>
<rc>00000014</rc>
<rsn>00005050</rsn>
<rsntext>Command processing error</rsntext>
</mbr>
<mbr name="IMS3 ">
<typ>IMS </typ>
<styp>DBDC </styp>
<rc>00000014</rc>
```

```

<rsn>00005050</rsn>
<rsntext>Command processing error</rsntext>
</mbr>
</cmderr>
<cmd>
<master>SYS3      </master>
<userid>USRT005 </userid>
<verb>DBR </verb>
<kwd>DB      </kwd>
<input>/DBR DB BANKATMS BANKTERM BANKLDGR BE3ORDER </input>
</cmd>
<msgdata>
<mbr name="SYS3      ">
<msg>DFS0488I  DBR  COMMAND COMPLETED.  DBN=  BANKATMS  RC=04</msg>
<msg>DFS0488I  DBR  COMMAND COMPLETED.  DBN=  BANKTERM  RC=04</msg>
<msg>DFS0488I  DBR  COMMAND COMPLETED.  DBN=  BANKLDGR  RC=04</msg>
<msg>DFS0488I  DBR  COMMAND COMPLETED.  DBN=  BE3ORDER  RC= 0</msg>
</mbr>
<mbr name="IMS3      ">
<msg>DFS0488I  DBR  COMMAND COMPLETED.  DBN=  BANKATMS  RC=04</msg>
<msg>DFS0488I  DBR  COMMAND COMPLETED.  DBN=  BANKTERM  RC=04</msg>
<msg>DFS0488I  DBR  COMMAND COMPLETED.  DBN=  BANKLDGR  RC=04</msg>
<msg>DFS0488I  DBR  COMMAND COMPLETED.  DBN=  BE3ORDER  RC= 0</msg>
</mbr>
</msgdata>
</imsout>

```

Explanation: The **DBR** command is routed from OM to the two active IMS systems -- SYS3 and IMS3. The response from both IMS systems is returned to OM. The databases BANKATMS, BANKTERM, BANKLDGR, and BE3ORDER are taken offline at both IMS systems.

### Related concepts

[Maintaining global information for databases, DEDB areas, and transactions \(System Administration\)](#)

### Related reference

[“IMS type-1 command format” on page 15](#)

This section describes the general format for an IMS type-1 command.

[z/OS: Recovering VSAM data sets](#)

[DFSVSMxx member of the IMS PROCLIB data set \(System Definition\)](#)

[UPDATE AREA command \(Commands\)](#)

[UPDATE DATAGR command \(Commands\)](#)

[UPDATE DB command \(Commands\)](#)

### Related information

[DFS2406I \(Messages and Codes\)](#)

[DFS2838I \(Messages and Codes\)](#)

## Chapter 22. /DELETE command

Use the **/DELETE** command to delete LU 6.2 descriptors.

This command can be issued to an IMSplex using the Batch SPOC utility.

Subsections:

- [“Environment” on page 343](#)
- [“Syntax” on page 343](#)
- [“Keywords” on page 343](#)

### Environment

The following table lists the environments (DB/DC, DBCTL, and DCCTL) in which you can use the command and keywords.

Table 181. Valid environments for the /DELETE command and keywords

| Command / Keywords | DB/DC | DBCTL | DCCTL |
|--------------------|-------|-------|-------|
| <b>/DELETE</b>     | X     | X     | X     |
| DESC               | X     |       | X     |

### Syntax

► **/DELETE** — DESC — *descriptorname* ►  
    **/DEL**

### Keywords

The following keyword is valid for the **/DELETE** command:

#### **DESC *descriptorname***

Specifies the LU62 descriptor to be deleted. Note that this will not delete the descriptor in the PROCLIB member. It is necessary to remove the descriptor from the PROCLIB member; otherwise, the descriptor will be defined at the next IMS restart.



---

## Chapter 23. DELETE commands

Use the IMS **DELETE** commands to delete Language Environment (LE) runtime options, resources, and resource descriptors.

These commands can be issued through TSO SPOC, IBM Management Console for IMS and DB2 for z/OS, the Manage Resources options in the IMS Applications menu, or other user-written programs that issue commands through OM API. These commands can also be issued to an IMSplex by using the Batch SPOC utility.

Subsections:

- [“DELETE DB command” on page 345](#)
- [“DELETE DBDESC command” on page 352](#)
- [“DELETE DEFN command” on page 358](#)
- [“DELETE IMSCON commands” on page 375](#)
- [“DELETE LE command” on page 389](#)
- [“DELETE OTMADESC command” on page 414](#)
- [“DELETE PGM command” on page 418](#)
- [“DELETE PGMDESC command” on page 423](#)
- [“DELETE RTC command” on page 428](#)
- [“DELETE RTCDESC command” on page 432](#)
- [“DELETE TRAN command” on page 437](#)
- [“DELETE TRANDESC command” on page 444](#)

---

### DELETE DB command

Use the **DELETE DB** command to delete database resources.

Subsections:

- [“Environment” on page 345](#)
- [“Syntax” on page 346](#)
- [“Keywords” on page 346](#)
- [“Usage notes” on page 346](#)
- [“Output fields” on page 347](#)
- [“Return, reason, and completion codes” on page 347](#)
- [“Examples” on page 350](#)

#### Environment

The following table lists the environments (DB/DC, DBCTL, and DCCTL) in which you can use the command and keywords.

---

*Table 182. Valid environments for the DELETE DB command and keywords*

| Command / Keywords | DB/DC | DBCTL | DCCTL |
|--------------------|-------|-------|-------|
| <b>DELETE DB</b>   | X     | X     |       |
| NAME               | X     | X     |       |
| OPTION             | X     | X     |       |

---

## Syntax

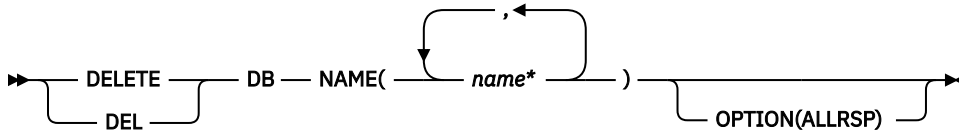

## Keywords

The following keywords are valid for the **DELETE DB** command:

### NAME

Specifies the 1-8 character name of the database. Wildcards are supported in the name. Examples of valid names are NAME(\*) and NAME(abc\*). If the NAME parameter specified is a specific or wildcard name, command responses are returned for all the resource names that are processed. For NAME(\*), command responses are returned only for the resource names that resulted in an error. For a **DEL DB** command when the database contains Fast Path areas, if all areas are successfully deleted, no area names are displayed. If the delete fails for any area, then all area names are displayed to show which deletes were successful and which were not.

### OPTION

Specifies additional functions to be performed along with the command.

#### ALLRSP

Indicates that the response lines are to be returned for all resources that are processed on the command. The default action is to return response lines only for the resources that resulted in an error. The ALLRSP keyword is valid only if NAME(\*) is specified.

## Usage notes

This command can only be issued through the Operations Manager API. This command applies to DB/DC systems, DBCTL systems, and DCCTL systems.

The **DELETE DB** command is not valid on the XRF alternate or FDBR region. This command is not valid if online change for MODBLKS is enabled (DFSDFxxx or DFSCGxxx defined with MODBLKS=OLC or MODBLKS not defined).

This command is recoverable.

Each database is deleted individually, unlike the online change process where either all databases are deleted or no databases are deleted. The runtime resource definition for a database can only be deleted if the database is not in use. If the database is in use, the delete fails. In a sysplex environment with multiple IMS subsystems, the delete might succeed on some IMS subsystems and fail on others.

The **DELETE DB** command removes ACB members from the 31-bit nonresident pool as well as the 64-bit storage pool.

The resources remain deleted across an IMS warm start or emergency restart. To ensure that the resources remain deleted across a cold start, the existing resource definitions must be exported to a system RDDS and then imported from the RDDS at cold start. Or, if the IMSRSC repository is enabled, the **DELETE DEFN** command must be issued to delete the definition from the repository. If the resource definitions are to be imported from the MODBLKS data set at cold start instead of from an RDDS or the repository, the resource definitions must be deleted from system definition and a new MODBLKS data set must be generated.

The database can be HSAM, HISAM, HDAM, HIDAM, DEDB, or a HALDB master database. The database cannot be a HALDB partition. If a database is logically related to another database, you need to consider

whether the logically related databases should also be deleted. For example, if the database is a HIDAM database, both the primary database and the index database must be deleted.

To delete a HALDB master database, a **/DBRECOVERY** command must be issued. The **/DBRECOVERY** command removes this IMS subsystem's knowledge of the HALDB partitions and stops the HALDB master database so that it can be deleted.

If the **DELETE** command is executed in an IMSplex using Resource Manager (RM) Structures, the database is not automatically removed from the structure. To remove the database, you can use the IMS Tools Resource Manager Structure utility that is included in IMS Tools Base v1.6 with APAR PH03561 or later. For more information, read the [IMS Tools Resource Manager Structure Utility](#) from the *IMS Tools Base* documentation. You can also use another vendor tool or write an RM client to delete resources from the resource structure.

## Output fields

The following table shows the **DELETE DB** output fields. The columns in the table are as follows:

### Short label

Contains the short label generated in the XML output.

### Long label

Contains the long label generated in the XML output.

### Keyword

Identifies keyword on the command that caused the field to be generated. N/A appears for output fields that are always returned. *error* appears for output fields that are returned only in case of an error.

### Meaning

Provides a brief description of the output field.

Table 183. Output fields for the **DELETE DB** command

| Short label | Long label | Keyword      | Meaning   |
|-------------|------------|--------------|---|
| CC          | CC         | N/A          | Completion code.  |
| CCTXT       | CCText     | <i>error</i> | Completion code text that briefly explains the meaning of the nonzero completion code.  |
| DB          | DBName     | N/A          | Database name being deleted.  |
| ERRT        | ErrorText  | <i>error</i> | Error text that provides diagnostic information. Error text can be returned for a nonzero completion code and further explains the completion code. |
| MBR         | MbrName    | N/A          | IMSplex member that built the output line.  |
| TYPE        | Type       | DB           | Resource type, which can be AREA, DEDB, DL/I, or blank (unknown). Resource type is returned only if areas are returned.                             |

## Return, reason, and completion codes

The following table includes the return and reason codes and a brief explanation of the codes. The return or reason code returned for the command might also indicate an error from a CSL request.

Table 184. Return and reason codes for the DELETE DB command

| Return code | Reason code | Meaning  |
|-------------|-------------|--|
| X'00000000' | X'00000000' | Command completed successfully. The command output contains a line for each resource, accompanied by its completion code. If NAME(*) is specified without OPTION(ALLRSP), no output lines are returned. See the completion code table for details.   |
| X'0000000C' | X'00003000' | Command was successful for some resources but failed for others. The command output contains a line for each resource, accompanied by its completion code. If NAME(*) is specified without OPTION(ALLRSP), only resources with nonzero completion codes are returned. See the completion code table for details. |
| X'0000000C' | X'00003004' | Command was not successful for any of the resources. The command output contains a line for each resource, accompanied by its completion code. See the completion code table for details.  |
| X'00000010' | X'0000400C' | Command is not valid on the XRF alternate.   |
| X'00000010' | X'00004120' | Online change phase is in progress.  |
| X'00000010' | X'00004200' | The <b>DELETE DB</b> command is not processed because IMS shutdown is in progress.   |
| X'00000010' | X'00004300' | Command is not allowed because online change for MODBLKS is enabled (DFSDFxxx or DFSCGxxx defined with MODBLKS=OLC, or MODBLKS not defined).   |
| X'00000010' | X'00004301' | Command is not allowed because the database has a logical relationship with another database.  |
| X'00000014' | X'00005004' | DFSOCMD response buffer could not be obtained.   |
| X'00000014' | X'00005008' | DFSPool storage could not be obtained.   |
| X'00000014' | X'0000500C' | AWE could not be obtained.   |

Errors unique to the processing of this command are returned as completion codes. The following table includes an explanation of the completion codes.

Table 185. Completion codes for the DELETE DB command

| Completion code | Completion code text      | Meaning  | Error text |
|-----------------|---------------------------|--|------------|
| 0               |                           | Command completed successfully for database.   |            |
| 8               | COMMAND COMPLETE FOR SOME | Command completed for some of the areas. Area names are returned with a completion code. |            |
| C               | COMMAND COMPLETE FOR NONE | Command failed for all of the areas. Area names are returned with completion codes.      |            |



Table 185. Completion codes for the DELETE DB command (continued)

| Completion code | Completion code text            | Meaning  | Error text |
|-----------------|---------------------------------|--|------------|
| 10              | NO RESOURCES FOUND              | Database name is invalid, or the wildcard parameter specified does not match any database names.   |            |
| 17              | ANOTHER CMD IN PROGRESS         | Another command (such as <b>DELETE</b> or <b>UPDATE</b> ) is in progress for this database. This could also mean this command, if the resource is specified by more than one specific or wildcard parameter. |            |
| 23              | DB STOP ACCESS IN PROGRESS      | A <b>/DBRECOVERY</b> or <b>UPDATE DB STOP (ACCESS)</b> command to stop database access is in progress. This takes the database offline.  |            |
| 25              | DB STOP UPDATES IN PROGRESS     | A <b>/DBDUMP</b> or <b>UPDATE DB STOP (UPDATES)</b> command to stop database updates is in progress for the database.  |            |
| 26              | DEDB STOP IN PROGRESS           | A <b>/DBRECOVERY</b> , <b>/STOP</b> , or <b>UPDATE DB STOP (SCHED)</b> command to stop database scheduling is in progress for a DEDB.  |            |
| 27              | REJECTED FOR DEFAULT DESCRIPTOR | <b>DELETE</b> command not allowed for user-defined default descriptor. You must issue an <b>UPDATE</b> command to set another descriptor as the default before deleting this descriptor.                     |            |
| 60              | GETMAIN STORAGE ERROR           | A GETMAIN request for storage was unsuccessful.  |            |
| 61              | DFSBCB STORAGE ERROR            | A storage request for a DDIR block failed.   |            |
| 65              | DMB POOL STORAGE ERROR          | During a <b>DELETE</b> command for a DB resource, there was an error in the DMB pool processing of a resident DMB.   |            |
| 6C              | NOT ALLOWED FOR HALDB PARTITION | <b>DELETE</b> is not allowed for a HALDB partition.  |            |

Table 185. Completion codes for the **DELETE DB** command (continued)

| Completion code | Completion code text           | Meaning   | Error text             |
|-----------------|--------------------------------|---|------------------------|
| 6F              | REFERENCED BY PROGRAM          | Program references the database to be deleted. The program name that references this database to be deleted is returned as error text. Suggested actions: Use online change for ACBLIB to change the PSB to no longer reference the database to be deleted or delete the PSB or issue <b>DELETE PGM</b> . | pgmname (8 characters) |
| 76              | RECOVER CMD ACTIVE             | <b>RECOVER START</b> command is in progress to recover one or more databases with the database recovery services.   |                        |
| 77              | DEPENDENT REGIONS ACTIVE       | One or more active dependent regions reference the database.  |                        |
| 90              | INTERNAL ERROR                 | An IMS system service failure.  |                        |
| DE              | ACBLIB READ FAILURE            | A read request for a member in ACBLIB failed.   |                        |
| E1              | DB MUST BE STOPPED AND OFFLINE | The database must be stopped and taken offline in order for the database to be deleted. You might need to issue a <b>/DBR DB STOP(ACCESS)</b> command or an <b>UPDATE DB STOP(ACCESS)</b> command to stop the database and take it offline before issuing the <b>DELETE DB</b> command.                   |                        |
| E2              | PARALLEL DB OPEN NOT COMPLETE  | The <b>DELETE DB</b> command was rejected because DB parallel open is in progress.  |                        |
| 1D7             | IMPORT CHANGE LIST ERROR       | Resource or descriptor is in the process of being imported from the change list in the IMSRSC repository, or the import from the change list failed. The resource cannot be deleted until it is successfully imported.  |                        |

### Examples

The following are examples of the **DELETE DB** command:

### Example 1 for DELETE DB command

TSO SPOC input:

```
DEL DB NAME(DBHIDO*,BADNAME,DEDBJ%%1,IPODB)
```

TSO SPOC output:

```
Response for: DEL DB NAME(DBHIDO*,BADNAME,DEDBJ%%1,IPODB)
DBName      MbrName      CC CText      ErrorText
BADNAME     IMS1          10 NO RESOURCES FOUND
DBHIDOK2    IMS1          E1 DATABASE HAS NOT BEEN DBR"D
DBHIDOK8    IMS1          6F REFERENCED BY PROGRAM      PBODSAGM
DBHIDOK8    IMS1          6F REFERENCED BY PROGRAM      PBODSAGR
DBHIDOK8    IMS1          6F REFERENCED BY PROGRAM      PBODSALU
DEDBJN01    IMS1          6F REFERENCED BY PROGRAM      DDLTLM02
DEDBJN21    IMS1          E1 DATABASE HAS NOT BEEN DBR"D
DEDBJ001    IMS1          E1 DATABASE HAS NOT BEEN DBR"D
DEDBJ011    IMS1          E1 DATABASE HAS NOT BEEN DBR"D
DEDBJ021    IMS1          0
DEDBJ031    IMS1          E1 DATABASE HAS NOT BEEN DBR"D
DEDBJ041    IMS1          E1 DATABASE HAS NOT BEEN DBR"D
DEDBJ051    IMS1          E1 DATABASE HAS NOT BEEN DBR"D
DEDBJ061    IMS1          E1 DATABASE HAS NOT BEEN DBR"D
DEDBJ071    IMS1          E1 DATABASE HAS NOT BEEN DBR"D
DEDBJ081    IMS1          E1 DATABASE HAS NOT BEEN DBR"D
DEDBJ091    IMS1          E1 DATABASE HAS NOT BEEN DBR"D
IPODB       IMS1          E1 DATABASE HAS NOT BEEN DBR"D
```

OM API input:

```
CMD(DEL DB NAME(DBHIDO*,BADNAME,DEDBJ%%1,IPODB))
```

OM API output:

```
<imsout>
<ctl>
<omname>OM10M </omname>
<omvsn>1.3.0</omvsn>
<xmlvsn>20 </xmlvsn>
<stime>2006.310 23:26:32.420713</stime>
<stotime>2006.310 23:26:32.422399</stotime>
<staseq>BFAACB33F8569D5C</staseq>
<stoseq>BFAACB33F8BFFD5C</stoseq>
<rqsttkn1>USRT011 10152632</rqsttkn1>
<rc>0200000C</rc>
<rsn>00003008</rsn>
<rsnmsg>CSLN054I</rsnmsg>
<rsntxt>None of the clients were successful.</rsntxt>
</ctl>
<cmderr>
<mbr name="IMS1 ">
<typ>IMS </typ>
<styp>DBDC </styp>
<rc>0000000C</rc>
<rsn>00003000</rsn>
<rsntxt>At least one request successful</rsntxt>
</mbr>
</cmderr>
<cmd>
<master>IMS1 </master>
<userid>USRT011 </userid>
<verb>DEL </verb>
<kwd>DB </kwd>
<input>DEL DB NAME(DBHIDO*,BADNAME,DEDBJ%%1,IPODB) </input>
</cmd>
<cmdsphdr>
<hdr slbl="DB" llbl="DBName" scope="LCL" sort="a"
key="1" scroll="no" len="8" dtype="CHAR" align="left" />
<hdr slbl="MBR" llbl="MbrName" scope="LCL" sort="a" key="2" scroll="no"
len="8" dtype="CHAR" align="left" />
<hdr slbl="CC" llbl="CC" scope="LCL" sort="n" key="0" scroll="yes"
len="4" dtype="INT" align="right" skipb="no" />
<hdr slbl="CCTXT" llbl="CCText" scope="LCL" sort="n" key="0"
scroll="yes" len="*" dtype="CHAR" skipb="yes" align="left" />
```

```

<hdr slbl="ERRT" llbl="ErrorText" scope="LCL" sort="n" key="0"
  scroll="yes" len="*" dtype="CHAR" skipb="yes" align="left" />
</cmdrsphdr>
<cmdrspdata>
<rsp>DB( DBHIDOK2) MBR(IMS1) CC( E1) CCTXT(DATABASE HAS NOT BEEN
DBR"D) </rsp>
<rsp>DB( BADNAME ) MBR(IMS1) CC( 10) CCTXT(NO RESOURCES FOUND) </rsp>
<rsp>DB( DEDBJN01) MBR(IMS1) CC( 6F) CCTXT(REFERENCED BY PROGRAM)
ERRT(DDLTLM02) </rsp>
<rsp>DB( IPODB ) MBR(IMS1) CC( E1) CCTXT(DATABASE HAS NOT BEEN
DBR"D) </rsp>
<rsp>DB( DBHIDOK8) MBR(IMS1) CC( 6F) CCTXT(REFERENCED BY PROGRAM)
ERRT(PBODSAGM) </rsp>
<rsp>DB( DEDBJN21) MBR(IMS1) CC( E1) CCTXT(DATABASE HAS NOT BEEN
DBR"D) </rsp>
<rsp>DB( DEDBJ001) MBR(IMS1) CC( E1) CCTXT(DATABASE HAS NOT BEEN
DBR"D) </rsp>
<rsp>DB( DEDBJ011) MBR(IMS1) CC( E1) CCTXT(DATABASE HAS NOT BEEN
DBR"D) </rsp>
<rsp>DB( DEDBJ021) MBR(IMS1) CC( 0) </rsp>
<rsp>DB( DEDBJ031) MBR(IMS1) CC( E1) CCTXT(DATABASE HAS NOT BEEN
DBR"D) </rsp>
<rsp>DB( DEDBJ041) MBR(IMS1) CC( E1) CCTXT(DATABASE HAS NOT BEEN
DBR"D) </rsp>
<rsp>DB( DEDBJ051) MBR(IMS1) CC( E1) CCTXT(DATABASE HAS NOT BEEN
DBR"D) </rsp>
<rsp>DB( DEDBJ061) MBR(IMS1) CC( E1) CCTXT(DATABASE HAS NOT BEEN
DBR"D) </rsp>
<rsp>DB( DEDBJ071) MBR(IMS1) CC( E1) CCTXT(DATABASE HAS NOT BEEN
DBR"D) </rsp>
<rsp>DB( DEDBJ081) MBR(IMS1) CC( E1) CCTXT(DATABASE HAS NOT BEEN
DBR"D) </rsp>
<rsp>DB( DEDBJ091) MBR(IMS1) CC( E1) CCTXT(DATABASE HAS NOT BEEN
DBR"D) </rsp>
<rsp>DB( DBHIDOK8) MBR(IMS1) CC( 6F) CCTXT(REFERENCED BY PROGRAM)
ERRT(PBODSAGR) </rsp>
<rsp>DB( DBHIDOK8) MBR(IMS1) CC( 6F) CCTXT(REFERENCED BY PROGRAM)
ERRT(PBODSALU) </rsp>
</cmdrspdata>
</imsout>

```

**Explanation:** A **DELETE DB** command was issued for several databases. The **DELETE DB** worked for one database, DEDBJ021, as shown by completion code 0. The **DELETE DB** command failed for several databases with completion code E1, because the databases need to be taken offline by use of the **/DBRECOVERY** command first. The **DELETE DB** command failed for databases DBHIDOK8 and DEDBJN01 with completion code 6F, because the databases are referenced by one or more programs. Each program name is displayed as error text.

### Related concepts

[How to interpret CSL request return and reason codes \(System Programming APIs\)](#)

### Related tasks

[Deleting runtime database resource and descriptor definitions with the DELETE command \(System Definition\)](#)

### Related reference

“Command keywords and their synonyms” on page 59

All IMS command keywords and their synonyms, as well as keywords supported by the OM API, are listed. The list covers command keywords for the OM command processing clients such as IMS, ODBM, IMSCON, and RM.

## DELETE DBDESC command

Use the **DELETE DBDESC** command to delete database descriptors.

Subsections:

- [“Environment” on page 353](#)
- [“Syntax” on page 353](#)
- [“Keywords” on page 353](#)
- [“Usage notes” on page 353](#)

- “Output fields” on page 354
- “Return, reason, and completion codes” on page 354
- “Examples” on page 356

## Environment

The following table lists the environments (DB/DC, DBCTL, and DCCTL) from which the command keywords can be issued.

Table 186. Valid environments for the DELETE DBDESC command and keywords

| Command / Keywords   | DB/DC | DBCTL | DCCTL |
|----------------------|-------|-------|-------|
| <b>DELETE DBDESC</b> | X     | X     |       |
| NAME                 | X     | X     |       |
| OPTION               | X     | X     |       |

## Syntax

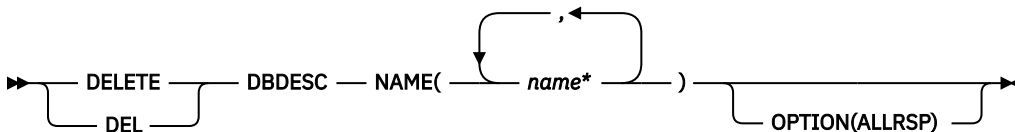

## Keywords

The following keywords are valid for the **DELETE DBDESC** command:

### NAME

Specifies the 1-8 character name of the database descriptor. Wildcards are supported in the name. Examples of valid names are NAME(\*) and NAME(abc\*). If the NAME parameter specified is a specific or wildcard name, command responses are returned for all the descriptor names that are processed. For NAME(\*), command responses are returned only for the descriptor names that resulted in an error. OPTION(ALLRSP) can be specified with NAME(\*) to obtain the command responses for all the descriptor names that are processed.

### OPTION

Specifies additional functions to be performed along with the command.

#### ALLRSP

Indicates that the response lines are to be returned for all descriptors that are processed on the command. The default action is to return response lines only for the descriptors that resulted in an error. It is valid only with NAME(\*). ALLRSP is ignored for other NAME values.

## Usage notes

This command can only be issued through the Operations Manager API. This command applies to DB/DC systems, and DBCTL system.

The **DELETE DBDESC** command is not valid on the XRF alternate or FDBR region. The **DELETE DBDESC** command is not valid if online change for MODBLKS is enabled (DFSDFxxx or DFSCGxxx defined with MODBLKS=OLC or MODBLKS not defined).

This command is recoverable.

Each descriptor is deleted individually. Individual deletion does not work like online change where either all descriptors are deleted or no descriptors are deleted. Descriptors can be successfully deleted if they are not currently in use. If a descriptor is in use, the delete fails. In a sysplex environment, the delete might succeed on some IMS systems and fail on others. A descriptor is in use if another command is in progress that references the descriptor.

The descriptors remain deleted across an IMS warm start or emergency restart. To ensure they remain deleted across a cold start, the existing descriptor definitions must be exported to an RDDS and imported from the RDDS during cold start.

The **DELETE DBDESC** command is not allowed for IMS descriptors that are identified with a definition type of IMS. For **DELETE DBDESC** commands, this means IMS database descriptor DFSDSDB1.

## Output fields

The following table shows the **DELETE DBDESC** output fields. The columns in the table are as follows:

### Short label

Contains the short label generated in the XML output.

### Long label

Contains the long label generated in the XML output.

### Keyword

Identifies keyword on the command that caused the field to be generated. N/A appears for output fields that are always returned. *error* appears for output fields that are returned only in case of an error.

### Meaning

Provides a brief description of the output field.

Table 187. Output fields for the **DELETE DBDESC** command

| Short label | Long label | Keyword      | Meaning  |
|-------------|------------|--------------|--|
| CC          | CC         | N/A          | Completion code.   |
| CCTXT       | CCText     | <i>error</i> | Completion code text that briefly explains the meaning of the non-zero completion code.  |
| DESC        | DescName   | DBDESC       | Database descriptor name.  |
| ERRT        | ErrorText  | <i>error</i> | Error text that provides diagnostic information. Error text can be returned for a non-zero completion code and further explains the completion code. |
| MBR         | MbrName    | N/A          | IMSplex member that built the output line.   |

## Return, reason, and completion codes

The following table includes the return and reason codes and a brief explanation of the codes. The return or reason code returned for the command might also indicate an error from a CSL request.

Table 188. Return and reason codes for the DELETE DBDESC command

| Return code | Reason code | Meaning   |
|-------------|-------------|---|
| X'00000000' | X'00000000' | Command completed successfully. The command output contains a line for each descriptor, accompanied by its completion code. If NAME(*) is specified without OPTION(ALLRSP), no output lines are returned. See the completion code table for details.  |
| X'0000000C' | X'00003000' | Command was successful for some descriptors but failed for others. The command output contains a line for each descriptor, accompanied by its completion code. If NAME(*) is specified without OPTION(ALLRSP), only descriptors with non-zero completion codes are returned. See the completion code table for details. |
| X'0000000C' | X'00003004' | Command was not successful for any of the descriptors. The command output contains a line for each descriptor, accompanied by its completion code. See the completion code table for details.   |
| X'00000010' | X'0000400C' | Command is not valid on the XRF alternate.  |
| X'00000010' | X'00004120' | Online change phase is in progress.   |
| X'00000010' | X'00004200' | The <b>DELETE DBDESC</b> command is not processed because IMS shutdown is in progress.  |
| X'00000010' | X'00004300' | Command is not allowed because online change for MODBLKS is enabled (DFSDFxxx or DFSCGxxx defined with MODBLKS=OLC, or MODBLKS not defined).  |
| X'00000014' | X'00005004' | DFSOCMD response buffer could not be obtained.  |
| X'00000014' | X'00005008' | DFSPool storage could not be obtained.  |
| X'00000014' | X'0000500C' | AWE could not be obtained.  |

Errors unique to the processing of this command are returned as completion codes. The following table includes an explanation of the completion codes.

Table 189. Completion codes for the DELETE DBDESC command

| Completion code | Completion code text    | Meaning   | Error text |
|-----------------|-------------------------|---|------------|
| 0               |                         | Command completed successfully for database descriptor.   |            |
| 17              | ANOTHER CMD IN PROGRESS | Another command (such as <b>DELETE</b> or <b>UPDATE</b> ) is in progress for this database descriptor. This could also mean this command, if the descriptor is specified by more than one specific or wildcard parameter. |            |

Table 189. Completion codes for the DELETE DBDESC command (continued)

| Completion code | Completion code text            | Meaning  | Error text |
|-----------------|---------------------------------|--|------------|
| 27              | REJECTED FOR DEFAULT DESCRIPTOR | <b>DELETE</b> command not allowed for user-defined default descriptor. You must issue an <b>UPDATE</b> command to set another descriptor as the default before deleting this descriptor.                     |            |
| 48              | NOT ALLOWED FOR IMS RESOURCE    | <b>DELETE</b> command not allowed for IMS defined-descriptor or resource. An IMS descriptor example is DFSDSDB1.   |            |
| 60              | GETMAIN STORAGE ERROR           | A GETMAIN request for storage was unsuccessful.  |            |
| 61              | DFSBCB STORAGE ERROR            | A storage request for a DDIR block failed.   |            |
| 90              | INTERNAL ERROR                  | AN IMS system service failure.   |            |
| 1D7             | IMPORT CHANGE LIST ERROR        | Descriptor is in the process of being imported from the change list in the IMSRSC repository, or the import from the change list failed. The descriptor cannot be deleted until it is successfully imported. |            |

### Examples

The following are examples of the **DELETE DBDESC** command:

#### Example 1 for DELETE DBDESC command

TSO SPOC input:

```
DEL DBDESC NAME(*) OPTION(ALLRSP)
```

TSO SPOC output:

```
Response for: DEL DBDESC NAME(*) OPTION(ALLRSP)
DescName MbrName CC CText
BRWSDDESC IMS1 27 REJECTED FOR DEFAULT DESCRIPTOR
DESC001 IMS1 0
DESC002 IMS1 0
DESC003 IMS1 0
DESC004 IMS1 0
DESC005 IMS1 0
DFSDSDB1 IMS1 48 NOT ALLOWED FOR IMS RESOURCE
EXCLDESC IMS1 0
RESDESC IMS1 0
```

OM API input:



```
CMD(DEL DBDESC NAME(*) OPTION(ALLRSP))
```

OM API output:

```
<imsout>
<ctl>
<omname>OM10M </omname>
<omvsn>1.3.0</omvsn>
<xmlvsn>20 </xmlvsn>
<stime>2006.310 23:15:13.678125</stime>
<stotime>2006.310 23:15:13.679097</stotime>
<staseq>BFAAC8ACABB2D8DC</staseq>
<stoseq>BFAAC8ACABEF9C5C</stoseq>
<rqsttkn1>USRT011 10151513</rqsttkn1>
<rc>0200000C</rc>
<rsn>00003008</rsn>
<rsnmsg>CSLN054I</rsnmsg>
<rsntxt>None of the clients were successful.</rsntxt>
</ctl>
<cmderr>
<mbr name="IMS1 ">
<typ>IMS </typ>
<styp>DBDC </styp>
<rc>0000000C</rc>
<rsn>00003000</rsn>
<rsntxt>At least one request successful</rsntxt>
</mbr>
</cmderr>
<cmd>
<master>IMS1 </master>
<userid>USRT011 </userid>
<verb>DEL </verb>
<kwd>DBDESC </kwd>
<input>DEL DBDESC NAME(*) OPTION(ALLRSP) </input>
</cmd>
<cmdrsphdr>
<hdr slbl="DESC" llbl="DescName" scope="LCL" sort="a" key="1"
scroll="no" len="8" dtype="CHAR" align="left" />
<hdr slbl="MBR" llbl="MbrName" scope="LCL" sort="a" key="2" scroll="no"
len="8" dtype="CHAR" align="left" />
<hdr slbl="CC" llbl="CC" scope="LCL" sort="n" key="0" scroll="yes"
len="4" dtype="INT" align="right" skipb="no" />
<hdr slbl="CCTXT" llbl="CCText" scope="LCL" sort="n" key="0"
scroll="yes" len="*" dtype="CHAR" skipb="yes" align="left" />
<hdr slbl="ERRT" llbl="ErrorText" scope="LCL" sort="n" key="0"
scroll="yes" len="*" dtype="CHAR" skipb="yes" align="left" />
</cmdrsphdr>
<cmdrspdata>
<rsp>DESC(EXCLDESC) MBR(IMS1) CC( 0) </rsp>
<rsp>DESC(DESC004 ) MBR(IMS1) CC( 0) </rsp>
<rsp>DESC(DESC005 ) MBR(IMS1) CC( 0) </rsp>
<rsp>DESC(DESC001 ) MBR(IMS1) CC( 0) </rsp>
<rsp>DESC(RESDESC ) MBR(IMS1) CC( 0) </rsp>
<rsp>DESC(BRWSDESC) MBR(IMS1) CC( 27) CCTXT(REJECTED FOR DEFAULT
DESCRIPTOR) </rsp>
<rsp>DESC(DESC002 ) MBR(IMS1) CC( 0) </rsp>
<rsp>DESC(DESC003 ) MBR(IMS1) CC( 0) </rsp>
<rsp>DESC(DFSDSDB1) MBR(IMS1) CC( 48) CCTXT(NOT ALLOWED FOR IMS
RESOURCE) </rsp>
</cmdrspdata>
</imsout>
```

**Explanation:** A **DELETE DBDESC** command is issued to delete all database descriptors from an active IMS system. Many database descriptors are successfully deleted, as indicated by the completion code 0. Because the **DELETE** command attempted to delete all of the database descriptors, **OPTION(ALLRSP)** is specified to display the successfully deleted database descriptors. Database descriptor **BRWSDESC** fails, because it is the default database descriptor. Database descriptor **DFSDSDB1** fails, because it is the IMS-defined database descriptor.

### Related concepts

[How to interpret CSL request return and reason codes \(System Programming APIs\)](#)

### Related reference

[“Command keywords and their synonyms” on page 59](#)

All IMS command keywords and their synonyms, as well as keywords supported by the OM API, are listed. The list covers command keywords for the OM command processing clients such as IMS, ODBM, IMSCON, and RM.

## DELETE DEFN command

Use the **DELETE DEFN** command to delete one or more stored resource definitions from the IMSRSC repository.

Subsections:

- [“Environment” on page 358](#)
- [“Syntax” on page 358](#)
- [“Keywords” on page 359](#)
- [“Usage notes” on page 363](#)
- [“Output fields” on page 364](#)
- [“Return, reason, and completion codes” on page 365](#)
- [“Examples” on page 368](#)

### Environment

The following table lists the environments (DB/DC, DBCTL, and DCCTL) in which you can use the command and keywords.

*Table 190. Valid environments for the DELETE DEFN command and keywords*

| Command / Keywords | DB/DC | DBCTL | DCCTL |
|--------------------|-------|-------|-------|
| <b>DELETE DEFN</b> | X     | X     | X     |
| FOR                | X     | X     | X     |
| NAME               | X     | X     | X     |
| OPTION             | X     | X     | X     |
| TARGET             | X     | X     | X     |
| TYPE               | X     | X     | X     |

### Syntax

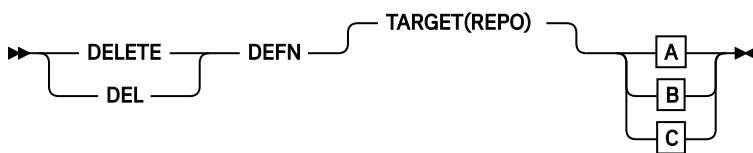

A

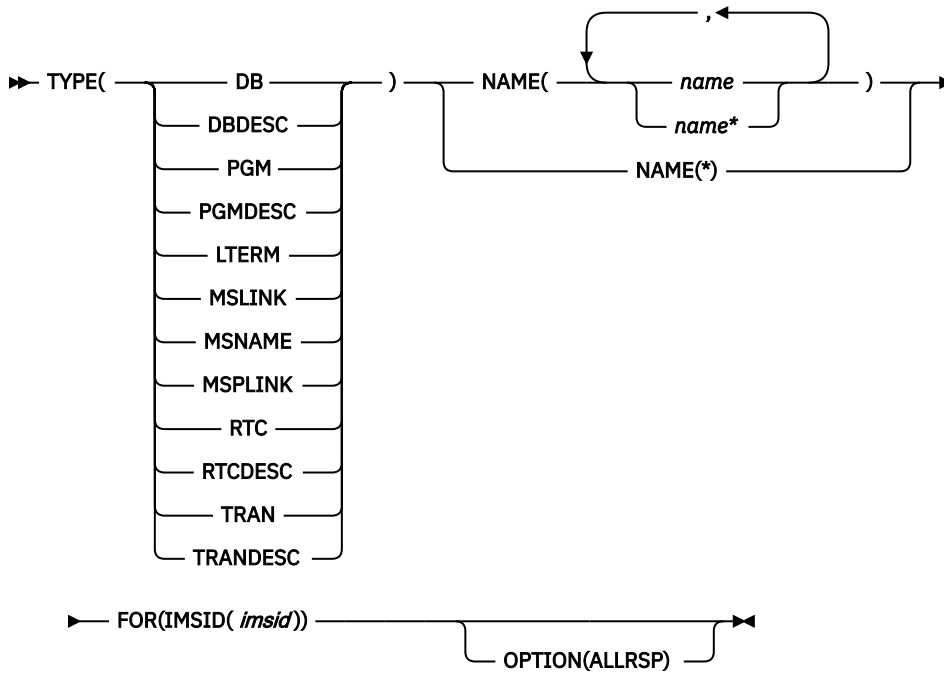

## B

► TYPE(CHGLIST) — FOR(IMSID( *imsid* )) →

## C

► TYPE(IMSIDMBR) — FOR(IMSID( *imsid* )) →

## Keywords

The following keywords are valid for the **DELETE DEFN** command:

### DEFN

Specifies that resource and descriptor definitions are to be deleted.

### TARGET

Indicates where the definitions must be deleted from. TARGET(REPO) is the default.

### REPO

TARGET(REPO) is valid only when IMS is enabled to use the repository. The **DELETE DEFN** command is defined to OM with ROUTE=ANY. OM routes the command to one command master IMS for processing.

All resource definitions are deleted from the repository as a single unit of work (UOW). If the deletion of any of the resource definitions results in an error, none of the resource definitions are deleted.

A resource definition not being found in the repository is not treated as an error in the command processing. If one or more resource definitions for the names that are specified on the **DELETE DEFN** command are not found in the repository, the command is processed for the names that have resource definitions in the repository.

If any CSLRPDEL errors are returned for the **DELETE** command, you must check to see whether there are any in-doubts. If the error is before the UOW is committed, all deletes from the repository are backed out. If the failure is during UOW commit and if the primary data set is updated, the UOW is committed. You must issue the **QUERY xxx SHOW(DEFN, IMSID)** commands to verify whether the resource definitions exist in the repository. If they still exist, you must reissue the **DELETE DEFN** command.

**Recommendation:** Avoid issuing the **DELETE DEFN TARGET(REPO) NAME(\*) FOR(IMSID(\*))** command during peak hours because deleting all the resource definitions from the repository can incur a larger than normal command response time. However, while the resource definitions are being deleted from the repository, there is no impact to other work in IMS.

## TYPE

Specifies the type of resource or descriptor definitions to delete.

### CHGLIST

Specifies that any residual IMS change list that could not be deleted by IMS during IMS change list processing is to be deleted.

If the IMS system goes down without deleting the change list, another change list cannot be created at the next **IMPORT DEFN SOURCE(REPO) SCOPE(ALL)** command. The **IMPORT** command will fail because the change list is locked and not accessible.

Use the CHGLIST keyword under the following situations:

- After a DFS4409A message (REPOSITORY CHANGE LIST IS NOT ACCESSIBLE) is issued and you issue an **IMPORT DEFN SOURCE(REPO) SCOPE(ALL)** command manually to successfully synchronize IMS with the repository.

Because the **IMPORT** command is issued manually, the change list is not needed and should be deleted. If the change list is not deleted, it is processed at the next IMS restart.

- After a DFS4401E message is issued (RM CSLRPDEL REQUEST FAILED) when IMS could not delete the change list.

Because IMS could not delete the change list automatically, you can use the **DELETE DEFN** command to delete the change list. If this residual change list is not deleted, it is deleted at the next IMS restart.

TYPE(CHGLIST) does not apply to TYPE LTERM, MSLINK, MSNAME, or MSPLINK.

## DB

Specifies that one or more database definitions are to be deleted from the repository. If TYPE(DB) is specified on a DCCTL system, completion code 1D3 ("REPOSITORY MEMBER NOT FOUND") is returned for each name specified.

### DBDESC

Specifies that one or more database descriptor definitions are to be deleted from the repository. If TYPE(DBDESC) is specified on a DCCTL system, completion code 1D3 ("REPOSITORY MEMBER NOT FOUND") is returned for each name specified.

## IMSIDMBR

TYPE(IMSIDMBR) can be used on the **DELETE DEFN** command to delete the IMS ID specified on the FOR(IMSID()) from the repository IMSID member table.

The **DELETE DEFN TARGET(REPO) TYPE(IMSIDMBR) FOR(IMSID())** command is processed by the command master IMS. The command will delete the IMS ID from the IMSID member table in the IMSRSC repository.

The **DELETE DEFN TYPE(IMSIDMBR)** command should be issued:

- before or after the **/CHE FREEZE | DUMPQ | PURGE LEAVEPLEX** command is issued to cleanup information of the IMS leaving the IMSplex from the IMSRSC repository.
- To remove an IMS ID of an inactive IMS from the repository that has been added in error. For example, if the **EXPORT DEFN** command or CSLURP10 utility specified an incorrect IMS ID on the IMS ID list.

Only a single specific IMS ID can be specified with TYPE(IMSIDMBR). Wildcard names or multiple IMS IDs are not supported.

The command will first check if any resource definitions exist in the IMSRSC repository for the IMS ID specified in the FOR(IMSID()). When any resource definitions exist in the repository for the

IMS ID, the command will fail. A response line is returned for each resource type that has one or more resource definitions existing in the repository for the IMS ID that is removed from the IMSID member table. A **DELETE DEFN TYPE(rsctype)** command must be issued to delete the resource definitions of the resource type that exist in the repository for the IMS and then reissue the **DELETE DEFN TYPE(IMSIDMBR)** command to remove the IMS ID from the repository IMSID member table.

If the command is successful, the IMS ID is removed from the IMSRSC repository. A response line is returned with the IMS ID that is removed from the IMSID member table. After the IMS ID is removed from the IMSID member table, a subsequent **EXPORT DEFN TARGET(REPO) SET(IMSID(\*))** command routed to any IMS or an autoexport when AUTOEXPORT\_IMSID=ALL is specified and is triggered by another IMS other than the IMS whose IMS ID is removed, will not write the resource definitions for the IMS that has been removed from the IMSID member table.

**Note:**

If the IMS that is removed from the repository is still active, an **EXPORT DEFN TARGET(REPO)** command directed to the IMS, or the next autoexport at the IMS if there are any changes, will write the resource definitions to the repository and re-add the IMS to the repository.

On a XRF system, if the active and alternate are leaving the IMSplex, then the **DELETE DEFN TYPE(IMSIDMBR)** command must be issued with the IMS ID of both the active and the alternate.

**LTERM**

Specifies that one or more Multiple Systems Coupling (MSC) remote logical terminal (LTERM) definitions are to be deleted from the repository. If TYPE(LTERM) is specified on a DBCTL system, completion code 1D3 ("REPOSITORY MEMBER NOT FOUND") is returned.

**MSLINK**

Specifies that one or more MSC logical link definitions are to be deleted from the repository. If TYPE(MSLINK) is specified on a DBCTL system, completion code 1D3 ("REPOSITORY MEMBER NOT FOUND") is returned.

**MSNAME**

Specifies that one or more MSC logical link path definitions are to be deleted from the repository. If TYPE(MSNAME) is specified on a DBCTL system, completion code 1D3 ("REPOSITORY MEMBER NOT FOUND") is returned.

**MSPLINK**

Specifies that one or more MSC physical link definitions are to be deleted from the repository. If TYPE(MSPLINK) is specified on a DBCTL system, completion code 1D3 ("REPOSITORY MEMBER NOT FOUND") is returned.

**PGM**

Specifies that one or more program definitions are to be deleted from the repository.

**PGMDESC**

Specifies that one or more program descriptor definitions are to be deleted from the repository.

**RTC**

Specifies that one or more routing code definitions are to be deleted from the repository. If TYPE(RTC) is specified on a DBCTL system, completion code 1D3 ("REPOSITORY MEMBER NOT FOUND") is returned for each name specified.

**RTCDESC**

Specifies that one or more routing code descriptor definitions are to be deleted from the repository. If TYPE(RTCDESC) is specified on a DBCTL system, completion code 1D3 ("REPOSITORY MEMBER NOT FOUND") is returned for each name specified.

**TRAN**

Specifies that one or more transaction definitions are to be deleted from the repository. If TYPE(TRAN) is specified on a DBCTL system, completion code 1D3 ("REPOSITORY MEMBER NOT FOUND") is returned for each name specified.

When an FP(E) transaction is deleted from the repository by using the **DELETE DEFN** command, the routing code that is associated with the FP(E) transaction will also be deleted from the repository by RM.

### **TRANDESC**

Specifies that one or more transaction descriptor definitions are to be deleted from the repository. If TYPE(TRANDESC) is specified on a DBCTL system, completion code 1D3 ("REPOSITORY MEMBER NOT FOUND") is returned for each name specified.

### **NAME**

Specifies the 1- to 8-character name of a resource or descriptor. Wildcards can be specified in the name. The name is a repeatable parameter. If the NAME parameter specified is a specific name or a wildcard, command responses are returned for all the resource names that are processed. NAME is a required parameter.

For NAME(\*), command responses are returned only for the resource and descriptor names that resulted in an error. OPTION(ALLRSP) can be specified with NAME(\*) to obtain the command responses for all the resource and descriptor names that are deleted.

NAME is not supported with TYPE(CHGLIST) or TYPE(IMSIDMBR).

### **FOR**

Specifies what actions to be set.

### **IMSID**

Specifies the list of IMS IDs for which the resource and descriptor definitions are to be deleted.

An IMS resource list is a list of resource and descriptor names and types that defines the resources for an IMS system. IMS resource lists exist in the repository and are used during IMS cold start to identify all the resource and descriptor definitions that are to be read during the cold start. The IMSID values specified on the **DELETE DEFN** command identify the IMS resource lists from which the resources are to be deleted when a stored resource definition is deleted from the repository.

The IMSID value can be a specific IMS ID, a list of specific IMS IDs, a wildcard name of \*, or a wildcard name with \* or %.

If the IMSID value specified is a wildcard name other than \*, the list of IMS IDs in RM that match the IMS ID wildcard name will be used on the command. The list of IMS IDs that are processed is returned on the command output.

IMSID(\*) indicates that all IMS resource lists must be updated to remove the resource name being deleted. As a result of the **DELETE DEFN** command, the resource definition does not belong to any IMS systems that are defined to use the repository.

You can specify one or more IMS IDs. When one or more IMS IDs are specified, only the IMS resource lists for the specified IMS IDs are modified to delete the resource names being deleted from the repository.

If the resource name belongs to one or more IMS resource lists, and the **DELETE DEFN** command does not specify deletion from all IMS IDs, the stored resource definition from the repository is not deleted. Only the IMS resource lists for the specified IMS subsystems are modified to delete the resource names that are specified on the command.

The IMS ID specified on the FOR(IMSID()) keyword must be an IMS that is defined to RM to use the repository. The IMS specified might be active or down when the command is issued.

Only a single specific IMS ID can be specified with the TYPE(CHGLIST) or TYPE(IMSIDMBR). Wildcard names or multiple IMS IDs are not supported.

### **OPTION**

Specifies additional functions to be performed along with the command.

## ALLRSP

Specifies that all response lines must be returned. You can specify `OPTION(ALLRSP)` only if `NAME(*)` is also specified. If `OPTION(ALLRSP)` is not specified, only the response lines for the names in error are returned.

`OPTION(ALLRSP)` is not valid when `NAME` parameters are specified. A response line is returned for each name that is specified on the `NAME` keyword.

## Usage notes

The **DELETE DEFN** command is valid from the Operations Manager (OM) API. This command is defined as `ROUTE=ANY` to OM and is processed only by the command master IMS.

You cannot delete an MSC physical link definition from the IMSRSC repository if the physical link is referenced by one or more logical links in the repository.

You cannot delete an MSC logical link definition from the IMSRSC repository if the logical link is referenced by one or more logical link paths in the repository.

You cannot delete an MSC logical link path definition from the IMSRSC repository if the logical link path is referenced by one or more remote LTERMs in the repository.

When you delete MSC resource definitions from the repository for multiple resource types, delete the definitions in the following order:

- Remote transaction definitions
- Remote LTERM definitions
- MSC logical link paths (MSNAMEs)
- MSC logical links (MSLINKs)
- MSC physical links (MSPLINKs)

The **DELETE DEFN TARGET(REPO)** command is enhanced to add the `TYPE(IMSIDMBR)` keyword.

The **DELETE DEFN TARGET(REPO) TYPE(IMSIDMBR) FOR(IMSID())** command is processed by the command master IMS. The command deletes the IMS ID from the IMSID member table in the IMSRSC repository.

You cannot delete a program definition from the repository if the program is referenced by one or more transaction or routing code definitions in the IMSRSC repository.

When you delete definitions from the repository for multiple resource types, delete the definitions in the following order:

1. Transaction and transaction descriptor definitions
2. Routing code and routing code descriptor definitions
3. Program and program descriptor definitions

Database and database descriptor definitions can be deleted at any time.

Before a program definition is deleted from the IMSRSC repository, each transaction and routing code definition that is in the repository is examined to determine whether it references the program. However, for performance reasons, if you specify `NAME(*)` on the **DELETE DEFN TARGET(REPO) TYPE(PGM)** command to delete all program definitions for the specified IMS system, the check is not made for the transaction and routing code definitions to determine whether they reference the program definitions. Instead, a check is made to determine whether any transactions or routing codes are defined in the repository for the specified IMS system. If one or more transactions or routing codes are defined in the repository for the IMS system, the command fails. The **DEL DEFN TARGET(REPO) TYPE(PGM) NAME(\*)** command also fails if a remote transaction definition is in the repository for the specified IMS system, even if the remote transaction definition does not reference a program. Therefore, if you issue the **DEL DEFN TARGET(REPO) TYPE(PGM)** command with `NAME(*)` specified, you must delete all transaction and routing code definitions from the repository before you issue the command.

As a result of the **DELETE DEFN** command with keyword DB, DBDESC, RTC, RTCDESC, PGM, PGMDESC, TRAN, or TRANDESC, definitions of the specified resource names are deleted from the IMSRSC repository for the specified IMS systems. Additionally, the **DELETE DEFN** command deletes the resource names from an IMS change list in the repository if a change list exists for one or more IMS systems that are specified on the FOR() keyword. Because the resource definition is being deleted and will not be available to be imported when the IMS system restarts, it is also deleted from the IMS system's change list.

The IMS change list in the repository is not created when a **DELETE DEFN** command is issued and one or more IMS systems that are specified on the FOR() keyword are down. When you delete a resource definition, delete the IMS runtime definition from IMS by using the **DELETE** command and then delete the stored resource definition from the repository by using the **DELETE DEFN** command. If the stored resource definition is deleted from the repository for the IMS before the runtime resource definition is deleted from the IMS system, the resource definition still exists in the IMS after restart. In this case, issue the **DELETE** command to delete the runtime resource definition after IMS restarts.

**Considerations for Fast Path exclusive transactions and their associated routing codes:** When you delete a definition for a Fast Path exclusive transaction from the repository, the definition for its associated routing code is also deleted. If you issue the **DELETE DEFN** command to delete a routing code definition from the repository and the routing code is associated with a Fast Path exclusive transaction, the deletion fails. To delete the routing code definition, you must first delete the transaction definition.

**Consideration for an XRF-capable system:** When the **DELETE DEFN** command is used in an XRF environment, and the resource definition exists in the IMSRSC repository for both the active system and the alternate system, you must issue the **DELETE DEFN** command with the IMS IDs of both the active system and the alternate system on the FOR(IMSID(*imsid*)) keyword.

## Output fields

The **DELETE DEFN TARGET(REPO)** command results in the DFS3406I message, which indicates that the deletion from the repository was successful, or the DFS3407E message, which indicates that the deletion was not successful. These messages include the repository name and repository type. If the deletion from the repository is not successful, the DFS3407E message consists of the CSLRPDEL request return code and reason code. The CSLRPDEL return and reason codes are in the CSLRRR macro.

The following table shows the **DELETE DEFN** output fields. The columns in the table are as follows:

### Short label

Contains the short label that is generated in the XML output.

### Long label

Contains the long label that is generated in the XML output.

### Keyword

Identifies keyword on the command that caused the field to be generated. N/A indicates output fields that are always returned. *error* indicates output fields that are returned only in case of an error.

### Meaning

Provides a brief description of the output field.

Table 191. Output fields for the **DELETE DEFN** command

| Short label | Long label | Keyword      | Meaning   |
|-------------|------------|--------------|---|
| CC          | CC         | N/A          | Completion code.  |
| CCTXT       | CCText     | <i>error</i> | Completion code text that briefly explains the meaning of the nonzero completion code.  |
| DTYP        | DelType    | N/A          | The value CHGLIST is returned under DelType if the resource name on the output line was deleted from the IMS change list and the IMS resource list. |



Table 191. Output fields for the DELETE DEFN command (continued)

| Short label | Long label | Keyword | Meaning   |
|-------------|------------|---------|---|
| IMSID       | IMSid      | N/A     | The names of IMS resource lists that are updated or deleted by the <b>DELETE DEFN</b> command.  |
| MBR         | MbrName    | N/A     | The IMS identifier of the command master IMS that processed the <b>DELETE DEFN</b> command.   |
| NAME        | Name       | N/A     | The name of the resource or descriptor definition that was updated or deleted from the repository, or the name of the IMS resource list that was updated in the repository.                   |
| TYPE        | Type       | N/A     | The resource or descriptor type, which can be DB, DBDESC, LTERM, MSLINK, MSNAME, MSPLINK, PGM, PGMDESC, RTC, RTCDESC, TRAN, or TRANDESC; or LIST for IMS resource lists; or IMSID for IMS ID. |

## Return, reason, and completion codes

The following table includes the return and reason codes and a brief explanation of the codes. The return or reason code returned for the command might also indicate an error from a CSL request.

Table 192. Return and reason codes for the DELETE DEFN command

| Return code | Reason code | Meaning   |
|-------------|-------------|---|
| X'00000000' | X'00000000' | Command completed successfully.   |
| X'0000000C' | X'00003004' | No requests were successful.  |
| X'00000008' | X'00002004' | Invalid command keyword or invalid command keyword combination.   |
| X'00000008' | X'00002009' | Multiple values for same attribute.   |
| X'00000008' | X'00002010' | Generic value not supported for parameter.  |
| X'00000008' | X'00002018' | Invalid characters in IMS ID.   |
| X'00000008' | X'00002141' | TYPE parameter conflict.  |
| X'00000010' | X'00004004' | No CQS address space.   |
| X'00000010' | X'00004018' | No resource structure, or resource structure not available.   |
| X'00000010' | X'0000402C' | Command is not valid because MSC is not enabled in the IMS system.  |
| X'00000010' | X'0000402D' | Command is not allowed because dynamic definition is not enabled for MSC. MSCRSCS=DYN is not specified in the MSC section of the DFSDFxxx member of the IMS PROCLIB data set. |
| X'00000010' | X'00004100' | Resource structure is full.   |
| X'00000010' | X'00004104' | No RM address space.  |
| X'00000010' | X'00004108' | No SCI address space.   |
| X'00000010' | X'00004500' | IMS is not enabled to use the repository.   |

Table 192. Return and reason codes for the DELETE DEFN command (continued)

| Return code | Reason code | Meaning   |
|-------------|-------------|---|
| X'00000010' | X'00004501' | RM is not enabled with the repository.  |
| X'00000010' | X'00004502' | Repository is not available.  |
| X'00000010' | X'00004503' | Repository is stopped.  |
| X'00000010' | X'00004504' | Repository spare recovery is in progress.   |
| X'00000010' | X'00004505' | No IMS resource list exists, or no resources for the resource type exist in the IMS resource list.  |
| X'00000010' | X'00004507' | Repository access is denied.  |
| X'00000010' | X'00004508' | Repository maximum put length exceeded.   |
| X'00000010' | X'00004509' | RM data version is lower than the IMS data version.   |
| X'00000010' | X'0000450A' | Repository Server is being shut down.   |
| X'00000010' | X'0000450B' | Repository Server is not available.   |
| X'00000010' | X'0000450C' | Repository Server is busy.  |
| X'00000010' | X'0000450D' | RM failed to define some of the internal fields that are related to the IMSRSC repository.  |
| X'00000010' | X'00004511' | Programs cannot be deleted because transactions exist for one or more IMS systems.  |
| X'00000010' | X'00004512' | Programs cannot be deleted because routing codes exist for one or more IMS systems.   |
| X'00000014' | X'0000501C' | IMODULE GETMAIN error.  |
| X'00000014' | X'00005100' | RM request error.   |
| X'00000014' | X'00005104' | CQS error.  |
| X'00000014' | X'00005108' | SCI request error.  |
| X'00000014' | X'00005110' | Repository error.   |
| X'00000014' | X'0000551C' | A request to update the repository was rejected. Either a corrupted resource list was detected, or the update request was rejected to prevent a corruption of the resource list. Contact IBM Software Support. Send in the output from the command in error, a dump of the local RM address space where the command executed or the dump of all RM address spaces in the IMSplex. Also, send a copy of the IMSRSC repository RID and RMD data sets. |

Errors unique to the processing of this command are returned as completion codes. The following table includes an explanation of the completion codes.

Table 193. Completion codes for the DELETE DEFN command

| Completion code | Completion code text | Meaning                                      |
|-----------------|----------------------|--|
| 0               |                      | Command completed successfully for database. |
| 10              | NO RESOURCES FOUND   | The specified resource was not found.        |

Table 193. Completion codes for the DELETE DEFN command (continued)

| Completion code | Completion code text         | Meaning   |
|-----------------|------------------------------|---|
| 39              | FP=E TRAN FOR RTC EXISTS     | A routing code definition is being deleted, but the routing code is associated with a Fast Path exclusive FP(E) transaction.  |
| 48              | NOT ALLOWED FOR IMS RESOURCE | The specified resource is not allowed.  |
| 5F              | INVALID CHARACTERS IN NAME   | The specified name contains invalid characters.   |
| 7B              | REFERENCED BY RTCODE         | A program definition is being deleted, but the program is referenced by one or more routing code definitions.   |
| 88              | REFERENCED BY TRAN           | A program definition is being deleted, but the program is referenced by one or more transaction definitions.  |
| 94              | RM REQUEST ERROR             | An error resulted in the command not being processed for the RM.  |
| 14D             | INVALID CHARACTER IN IMSID   | There is an invalid character in the IMS ID.  |
| 1D0             | NOT DONE DUE TO ERROR        | An error resulted in the command not being processed for the resource name in the response line. The resource name that had the error will show the error that was encountered. All other resource names will have 1D0 completion code because the deletion was aborted due to one error. All members are deleted as a single unit of work. |
| 1D1             | NO RESPOSITORY DEFINED       | An error resulted due to repository not being defined.  |
| 1D3             | MEMBER NOT FOUND             | The specified resource name is not found.   |
| 1D4             | REPOSITORY MEMBER IN USE     | The specified repository member is already in use.  |
| 1D5             | NO IMS RESOURCE LIST         | The specified IMS resource list is not found.   |
| 1D6             | REPOSITORY ERROR             | An error resulted due to a repository error.  |
| 1D8             | CHANGE LIST IN USE           | The <b>DELETE DEFN TARGET(REPO)</b> command could not be completed because the change list for an IMS was in use and not accessible to be deleted.  |

Table 193. Completion codes for the DELETE DEFN command (continued)

| Completion code | Completion code text          | Meaning  |
|-----------------|-------------------------------|--|
| 1D9             | DEFINITIONS EXIST FOR RSCTYPE | The IMS ID cannot be deleted as resource definitions exist for the resource type specified under TYPE column. Resource definitions must be deleted before the IMS ID can be deleted. |
| 209             | REFERENCED BY MSLINK          | The physical link cannot be deleted because a logical link is assigned to the physical link.   |
| 20A             | REFERENCED BY MSNAME          | The logical link cannot be deleted because it is referenced by one or more logical link paths (MSNAMEs).   |
| 20B             | REFERENCED BY LTERM           | The MSNAME cannot be deleted because it is referenced by one of more remote LTERMs.  |

### Examples

The following are examples of the **DELETE DEFN** command:

#### Example 1 for DELETE DEFN command

TSO SPOC input:

```
DELETE DEFN TARGET(REPO) NAME(*) TYPE(DB) FOR(IMSID(*))
```

TSO SPOC output:

```
IMSpIex . . . . . : PLEX1
Routing . . . . . :
Start time . . . . : 2011.133 12:45:21.34
Stop time . . . . . : 2011.133 12:45:21.82
Return code . . . . : 00000000
Reason code . . . . : 00000000
Reason text . . . . :
Command master. . . : IMS1

MbrName  Messages
-----
IMS1     DFS3406I DELETE COMMAND COMPLETE FOR ALL, REPOTYPE=IMSRSC,
        REPONAME=IMSRSC_REPOSITORY
```

OM API input:

```
CMD(DELETE DEFN TARGET(REPO) NAME(*) TYPE(DB) FOR(IMSID(*)))
```

OM API output:

```
<imsout>
<ctl>
<omname>OM10M  </omname>
<omvsn>1.5.0</omvsn>
<xmlvsn>20  </xmlvsn>
<statime>2011.133 19:45:21.399790</statime>
<stotime>2011.133 19:45:21.823791</stotime>
<staseq>C7C3DD48D2FEE475</staseq>
<stoseq>C7C3DD493A82F2A5</stoseq>
<rqsttkn1>USRT011 10124521</rqsttkn1>
<rc>00000000</rc>
<rsn>00000000</rsn>
```

```

</ctl>
<cmd>
<master>IMS1    </master>
<userid>USRT011 </userid>
<verb>DEL </verb>
<kwd>DEFN      </kwd>
<input>DEL DEFN TARGET(REPO) NAME(*) TYPE(DB) FOR(IMSID(*)) </input>
</cmd>
<msgdata>
<mbi name="IMS1    ">
<msg>DFS3406I DELETE COMMAND COMPLETE FOR ALL, REPOTYPE=IMSRSC,
  REPONAME=IMSRSC_REPOSITORY          </msg>
</mbi>
</msgdata>
</imsout>

```

**Explanation:** All the stored resource definitions for all the database resources and descriptors are deleted in the repository. This command is processed by the command master IMS. The resource list for all IMS systems that are defined to use the repository is updated.

### Example 2 for DELETE DEFN command

TSO SPOC input:

```

DEL DEFN TARGET(REPO) TYPE(RTC) NAME(EMHTX2,RTC2)
FOR(IMSID(IMS2,IMS3))

```

TSO SPOC output:

```

Response for: DEL DEFN TARGET(REPO) TYPE(RTC) NAME(EMHTX2,RTC2)
              FOR(IMSID(IMS2,IMS3))
Name      Type      MbrName  CC  CCText      IMSid
IMS2      LIST      IMS1     0
IMS3      LIST      IMS1     0
EMHTX2    RTC        IMS1     0            IMS2
EMHTX2    RTC        IMS1     0            IMS3
RTC2      RTC        IMS1     1D3 REPOSITORY MEMBER NOT FOUND

```

When the PF4 key is pressed, the following is displayed:

```

Log for . . : DEL DEFN TARGET(REPO) TYPE(RTC) NAME(EMHTX2,RTC... More:

IMSpIex . . . . . : PLEX1
Routing . . . . . :
Start time. . . . : 2011.133 11:41:54.47
Stop time . . . . : 2011.133 11:41:54.55
Return code . . . : 0200000C
Reason code . . . : 00003008
Reason text . . . : None of the clients were successful.
Command master. . : IMS1

MbrName      Return      Reason
Code         Code         Reason text
-----
IMS1         0000000C    00003000    At least one request successful

MbrName      Messages
-----
IMS1         DFS3407E DELETE COMMAND COMPLETE FOR SOME, REPOTYPE=IMSRSC,
          REPONAME=IMSRSC_REPOSITORY

```

OM API input:

```

CMD(DEL DEFN TARGET(REPO) TYPE(RTC) NAME(EMHTX2,RTC2)
FOR(IMSID(IMS2,IMS3)))

```

OM API output:

```

<imsout>
<ctl>
<omname>OM10M </omname>
<omvsn>1.5.0</omvsn>
<xmIvsn>20 </xmIvsn>
<statime>2011.133 18:41:54.498030</statime>
<stotime>2011.133 18:41:54.547807</stotime>

```

```

<staseq>C7C3CF1A479EE33C</staseq>
<stoseq>C7C3CF1A53C5FFF0</stoseq>
<rqsttkn1>USRT011 10114154</rqsttkn1>
<rc>0200000C</rc>
<rsn>00003008</rsn>
<rsnmsg>CSLN054I</rsnmsg>
<rsntxt>None of the clients were successful.</rsntxt>
</ctl>
<cmderr>
<mbri name="IMS1 ">
<typ>IMS </typ>
<styp>DBDC </styp>
<rc>0000000C</rc>
<rsn>00003000</rsn>
<rsntxt>At least one request successful</rsntxt>
</mbri>
</cmderr>
<cmd>
<master>IMS1 </master>
<userid>USRT011 </userid>
<verb>DEL </verb>
<kwd>DEFN </kwd>
<input>DEL DEFN TARGET(REPO) TYPE(RTC) NAME(EMHTX2,RTC2)
FOR(IMSID(IMS2,IMS3)) </input>
</cmd>
<cmdrsphdr>
<hdr s1bl="NAME" llbl="Name" scope="LCL" sort="a" key="2" scroll="no"
len="8" dtype="CHAR" align="left" />
<hdr s1bl="TYPE" llbl="Type" scope="LCL" sort="a" key="1" scroll="no"
len="8" dtype="CHAR" align="left" />
<hdr s1bl="MBR" llbl="MbrName" scope="LCL" sort="a" key="3" scroll="no"
len="8" dtype="CHAR" align="left" />
<hdr s1bl="CC" llbl="CC" scope="LCL" sort="n" key="0" scroll="yes"
len="4" dtype="INT" align="right" />
<hdr s1bl="CCTXT" llbl="CCText" scope="LCL" sort="n" key="0"
scroll="yes" len="32" dtype="CHAR" align="left" skipb="yes" />
<hdr s1bl="IMSID" llbl="IMSid" scope="LCL" sort="a" key="4" scroll="no"
len="8" dtype="CHAR" align="left" skipb="yes" />
</cmdrsphdr>
<cmdrspdata>
<rsp>NAME(IMS2 ) TYPE(LIST) MBR(IMS1) CC( 0) </rsp>
<rsp>NAME(IMS3 ) TYPE(LIST) MBR(IMS1) CC( 0) </rsp>
<rsp>NAME(RTC2 ) TYPE(RTC) MBR(IMS1) CC( 1D3) CCTXT(REPOSITORY
MEMBER NOT FOUND)</rsp>
<rsp>NAME(EMHTX2 ) TYPE(RTC) MBR(IMS1) CC( 0) IMSID(IMS2 ) </rsp>
<rsp>NAME(EMHTX2 ) TYPE(RTC) MBR(IMS1) CC( 0) IMSID(IMS3 ) </rsp>
</cmdrspdata>
<msgdata>
<mbri name="IMS1 ">
<msg>DFS3407E DELETE COMMAND COMPLETE FOR SOME, REPOTYPE=IMSRSC,
REPONAME=IMSRSC_REPOSITORY </msg>
</mbri>
</msgdata>
</imsout>

```

**Explanation:** Routing code resource EMHTX2 exists in the IMSRSC repository, and routing code resource RTC2 does not exist in the repository. The **DELETE DEFN** command completed successfully with some of the resources deleted. IMS1 processed the **DELETE DEFN** command on behalf of IMS2 and IMS3. Routing code resource EMHTX2 in the repository is deleted for both IMS2 and IMS3. The resource list of IMS2 and the resource list of IMS3 are updated to remove routing code resource EMHTX2 from the resource lists. IMS2 and IMS3 do not have routing code resource RTC2 in the repository. The completion code is 1D3, and the completion code text is REPOSITORY MEMBER NOT FOUND.

### Example 3 for DELETE DEFN command

TSO SPOC input:

```

DEL DEFN TARGET(REPO) TYPE(RTC) NAME(EMHTX2,RTC2)
FOR(IMSID(IMS2,IMS3))

```

TSO SPOC output:

```

Response for: DEL DEFN TARGET(REPO) TYPE(RTC) NAME(EMHTX2,RTC2)
FOR(IMSID(IMS2,IMS3))
Name      Type      MbrName  CC  CCText
IMS2     LIST      IMS1     1D0 NOT DONE DUE TO ERROR

```

```

IMS3      LIST      IMS1      1D0 NOT DONE DUE TO ERROR
EMHTX2    RTC       IMS1      1D3 REPOSITORY MEMBER NOT FOUND
RTC2      RTC       IMS1      1D3 REPOSITORY MEMBER NOT FOUND

```

When the PF4 key is pressed, the following is displayed:

```
Log for . . : DEL DEFN TARGET(REPO) TYPE(RTC) NAME(EMHTX2,RTC... More: +>
```

```

IMSpIex . . . . . : PLEX1
Routing . . . . . :
Start time . . . . : 2011.133 12:07:41.08
Stop time . . . . . : 2011.133 12:07:41.14
Return code . . . . : 0200000C
Reason code . . . . : 00003008
Reason text . . . . : None of the clients were successful.
Command master . . : IMS1

```

| MbrName | Return Code | Reason Code | Reason text                 |
|---------|-------------|-------------|-----------------------------|
| IMS1    | 0000000C    | 00003004    | No requests were successful |

```

MbrName Messages
-----
IMS1      DFS3407E DELETE COMMAND COMPLETE FOR NONE, REQUEST=CSLRPDEL, RC=0300000C,
          RSN=00003004, ERRORTXT=, MBR=RSC, REPOTYPE=IMSRSC,
          REPONAME=IMSRSC_REPOSITORY

```

OM API input:

```

CMD(DEL DEFN TARGET(REPO) TYPE(RTC) NAME(EMHTX2,RTC2)
FOR(IMSID(IMS2,IMS3)))

```

OM API output:

```

<imsout>
<ctl>
<omname>OM10M </omname>
<omvsn>1.5.0</omvsn>
<xmlvsn>20 </xmlvsn>
<statime>2011.133 19:07:41.108147</statime>
<stotime>2011.133 19:07:41.139772</stotime>
<staseq>C7C3D4DD3DFB3522</staseq>
<stoseq>C7C3D4DD45B3CC2C</stoseq>
<rqsttkn1>USRT011 10120741</rqsttkn1>
<rc>02000000C</rc>
<rsn>00003008</rsn>
<rsnmsg>CSLN054I</rsnmsg>
<rsntxt>None of the clients were successful.</rsntxt>
</ctl>
<cmderr>
<mbr name="IMS1 ">
<typ>IMS </typ>
<styp>DBDC </styp>
<rc>00000000C</rc>
<rsn>00003004</rsn>
<rsntxt>No requests were successful</rsntxt>
</mbr>
</cmderr>
<cmd>
<master>IMS1 </master>
<userid>USRT011 </userid>
<verb>DEL </verb>
<kwd>DEFN </kwd>
<input>DEL DEFN TARGET(REPO) TYPE(RTC) NAME(EMHTX2,RTC2)
FOR(IMSID(IMS2,IMS3)) </input>
</cmd>
<cmdsphdr>
<hdr slbl="NAME" llbl="Name" scope="LCL" sort="a" key="2" scroll="no"
len="8" dtype="CHAR" align="left" />
<hdr slbl="TYPE" llbl="Type" scope="LCL" sort="a" key="1" scroll="no"
len="8" dtype="CHAR" align="left" />
<hdr slbl="MBR" llbl="MbrName" scope="LCL" sort="a" key="3" scroll="no"
len="8" dtype="CHAR" align="left" />
<hdr slbl="CC" llbl="CC" scope="LCL" sort="n" key="0" scroll="yes"
len="4" dtype="INT" align="right" />
<hdr slbl="CCTXT" llbl="CCText" scope="LCL" sort="n" key="0"
scroll="yes" len="32" dtype="CHAR" align="left" skipb="yes" />

```

```

<hdr slbl="IMSID" llbl="IMSid" scope="LCL" sort="a" key="4" scroll="no"
  len="8" dtype="CHAR" align="left" skipb="yes" />
</cmdrphdr>
<cmdrspdata>
<rsp>NAME(IMS2   ) TYPE(LIST) MBR(IMS1) CC( 1D0) CCTXT(NOT DONE DUE TO ERROR) </
rsp>
<rsp>NAME(IMS3   ) TYPE(LIST) MBR(IMS1) CC( 1D0) CCTXT(NOT DONE DUE TO ERROR) </
rsp>
<rsp>NAME(EMHTX2 ) TYPE(RTC) MBR(IMS1) CC( 1D3) CCTXT(REPOSITORY MEMBER NOT FOUND) </rsp>
<rsp>NAME(RTC2   ) TYPE(RTC) MBR(IMS1) CC( 1D3) CCTXT(REPOSITORY MEMBER NOT FOUND) </
rsp>
</cmdrspdata>
<msgdata>
<mbi name="IMS1   ">
<msg>DFS3407E DELETE COMMAND COMPLETE FOR NONE, REQUEST=CSLRPDEL,
RC=0300000C, RSN=00003004, ERRORTXT=, MBR=RSC, REPOTYPE=IMSRSC,
  REPONAME=IMSRSC_REPOSITORY                               </msg>
</mbi>
</msgdata>
</imsout>

```

**Explanation:** Routing code resources EMHTX2 and RTC2 do not exist in the IMSRSC repository. The **DELETE DEFN** command completed successfully with none of the resources deleted. IMS1 processed the **DELETE DEFN** command on behalf of IMS2 and IMS3. IMS2 and IMS3 do not have routing code resources EMHTX2 and RTC2 in the repository. The completion code is 1D3, and the completion code text is REPOSITORY MEMBER NOT FOUND. The resource list of IMS2 and the resource list of IMS3 are not updated due to error. The completion code is 1D0, and the completion code text is NOT DONE DUE TO ERROR.

#### Example 4 for DELETE DEFN command

TSO SPOC input:

```

DEL DEFN TARGET(REPO) TYPE(RTC) NAME(EMH*,R*)
FOR(IMSID(IMS2,IMS3))

```

TSO SPOC output:

```

Response for: DEL DEFN TARGET(REPO) TYPE(RTC) NAME(EMH*,R*)
              FOR(IMSID(IMS2,IMS3))
Name         Type      MbrName  CC   IMSid
IMS2         LIST      IMS1     0
IMS3         LIST      IMS1     0
EMHTX3       RTC        IMS1     0   IMS2
EMHTX3       RTC        IMS1     0   IMS3
RTC3         RTC        IMS1     0   IMS2
RTC3         RTC        IMS1     0   IMS3

```

When the PF4 key is pressed, the following is displayed:

```

Log for . . . : DEL DEFN TARGET(REPO) TYPE(RTC) NAME(EMH*,R*) FO... More:  >

IMSpIex . . . . . : PLEX1
Routing . . . . . :
Start time . . . . : 2011.133 12:22:50.10
Stop time . . . . . : 2011.133 12:22:50.17
Return code . . . . : 00000000
Reason code . . . . : 00000000
Reason text . . . . :
Command master . . : IMS1

MbrName  Messages
-----
IMS1     DFS3406I DELETE COMMAND COMPLETE FOR ALL, REPOTYPE=IMSRSC,
        REPONAME=IMSRSC_REPOSITORY

```

OM API input:

```

CMD(DEL DEFN TARGET(REPO) TYPE(RTC) NAME(EMH*,R*)
FOR(IMSID(IMS2,IMS3)))

```

OM API output:



```

<imsout>
<ctl>
<omname>OM10M </omname>
<omvsn>1.5.0</omvsn>
<xmlvsn>20 </xmlvsn>
<statime>2011.133 19:22:50.121164</statime>
<stotime>2011.133 19:22:50.167741</stotime>
<staseq>C7C3D84024FCC3A0</staseq>
<stoseq>C7C3D840305BDD22</stoseq>
<rqsttkn1>USRT011 10122250</rqsttkn1>
<rc>00000000</rc>
<rsn>00000000</rsn>
</ctl>
<cmd>
<master>IMS1 </master>
<userid>USRT011 </userid>
<verb>DEL </verb>
<kwd>DEFN </kwd>
<input>DEL DEFN TARGET(REPO) TYPE(RTC) NAME(EMH*,R*)
FOR(IMSID(IMS2,IMS3)) </input>
</cmd>
<cmdrsphdr>
<hdr slbl="NAME" llbl="Name" scope="LCL" sort="a" key="2" scroll="no"
len="8" dtype="CHAR" align="left" />
<hdr slbl="TYPE" llbl="Type" scope="LCL" sort="a" key="1" scroll="no"
len="8" dtype="CHAR" align="left" />
<hdr slbl="MBR" llbl="MbrName" scope="LCL" sort="a" key="3" scroll="no"
len="8" dtype="CHAR" align="left" />
<hdr slbl="CC" llbl="CC" scope="LCL" sort="n" key="0" scroll="yes"
len="4" dtype="INT" align="right" />
<hdr slbl="CCTXT" llbl="CCText" scope="LCL" sort="n" key="0"
scroll="yes" len="32" dtype="CHAR" align="left" skipb="yes" />
<hdr slbl="IMSID" llbl="IMSId" scope="LCL" sort="a" key="4" scroll="no"
len="8" dtype="CHAR" align="left" skipb="yes" />
</cmdrsphdr>
<cmdrspdata>
<rsp>NAME(IMS2 ) TYPE(LIST) MBR(IMS1) CC( 0) </rsp>
<rsp>NAME(IMS3 ) TYPE(LIST) MBR(IMS1) CC( 0) </rsp>
<rsp>NAME(EMHTX3 ) TYPE(RTC) MBR(IMS1) CC( 0) IMSID(IMS2 ) </rsp>
<rsp>NAME(RTC3 ) TYPE(RTC) MBR(IMS1) CC( 0) IMSID(IMS2 ) </rsp>
<rsp>NAME(EMHTX3 ) TYPE(RTC) MBR(IMS1) CC( 0) IMSID(IMS3 ) </rsp>
<rsp>NAME(RTC3 ) TYPE(RTC) MBR(IMS1) CC( 0) IMSID(IMS3 ) </rsp>
</cmdrspdata>
<msgdata>
<mbr name="IMS1 ">
<msg>DFS3406I DELETE COMMAND COMPLETE FOR ALL, REPOTYPE=IMSRSC,
REPONAME=IMSRSC_REPOSITORY </msg>
</mbr>
</msgdata>
</imsout>

```

**Explanation:** Routing code resources EMHTX3 and RTC3 exist in the IMSRSC repository. The **DELETE DEFN** command completed successfully with all of the resources deleted. IMS1 processed the **DELETE DEFN** command on behalf of IMS2 and IMS3. Routing code resource EMHTX3 that exists in the repository matched the wildcard resource name of EMH\*. Routing code resource RTC3 that exists in the repository matched the wildcard resource name of R\*. Routing code resources EMHTX3 and RTC3 exist in the repository for IMS2 and IMS3. Routing code resources EMHTX3 and RTC3 are deleted from the repository for IMS2 and IMS3. The resource list of IMS2 and the resource list of IMS3 are updated to remove routing code resources EMHTX3 and RTC3 from the resource lists.

#### **Example 5 for DELETE DEFN command**

Entry ET:

```
DELETE DEFN TYPE(IMSIDMBR) FOR(IMSID(IMS1))
```

Response ET:

| Name | Type   | MbrName | CC  | CCText                        |
|------|--------|---------|-----|-------------------------------|
| IMS1 | DB     | IMS2    | 1D9 | DEFINITIONS EXIST FOR RSCTYPE |
| IMS1 | DBDESC | IMS2    | 1D9 | DEFINITIONS EXIST FOR RSCTYPE |
| IMS1 | IMSID  | IMS2    | 1D0 | NOT DONE DUE TO ERROR         |

|      |          |      |     |                               |
|------|----------|------|-----|-------------------------------|
| IMS1 | PGM      | IMS2 | 1D9 | DEFINITIONS EXIST FOR RSCTYPE |
| IMS1 | PGMDESC  | IMS2 | 1D9 | DEFINITIONS EXIST FOR RSCTYPE |
| IMS1 | RTC      | IMS2 | 1D9 | DEFINITIONS EXIST FOR RSCTYPE |
| IMS1 | RTCDESC  | IMS2 | 1D9 | DEFINITIONS EXIST FOR RSCTYPE |
| IMS1 | TRAN     | IMS2 | 1D9 | DEFINITIONS EXIST FOR RSCTYPE |
| IMS1 | TRANDESC | IMS2 | 1D9 | DEFINITIONS EXIST FOR RSCTYPE |

**Explanation:** The **DELETE DEFN TYPE(IMSIDMBR) FOR(IMSID(IMS1))** command deletes the IMS ID IMS1 from the repository IMSID member table. The command fails as resource definitions of all 8 types exist in the repository for the IMS ID IMS1. You must issue **DELETE DEFN TARGET(REPO) FOR(IMSID(IMS1)) NAME(\*) TYPE(rsctype)** where *rsctype* is **DB|DBDESC|PGM|PGMDESC|RTC|RTCDESC|TRAN|TRANDESC** to delete one or more resource definitions of the resource type in the repository for the IMS ID IMS1. After this command, the **DELETE DEFN TYPE(IMSIDMBR) FOR(IMSID(IMS1))** command must be re-issued.

**Example 6 for DELETE DEFN command**

Entry ET:

```
DELETE DEFN TYPE(IMSIDMBR) FOR(IMSID(IMS1))
```

Response ET:

| Name | Type  | MbrName | CC |
|------|-------|---------|----|
| IMS1 | IMSID | IMS2    | 0  |

**Explanation:** The **DELETE DEFN TYPE(IMSIDMBR) FOR(IMSID(IMS1))** command deletes the IMS ID IMS1 from the repository IMSID member table. If the command is successful, IMS1 is no longer defined in the IMSRSC repository.

**Example 7 for DELETE DEFN command**

Entry ET:

```
DELETE DEFN TYPE(IMSIDMBR) FOR(IMSID(IMSX))
```

Response ET:

| Name | Type  | MbrName | CC  | CCText                      |
|------|-------|---------|-----|-----------------------------|
| IMSX | IMSID | IMS1    | 1D3 | REPOSITORY MEMBER NOT FOUND |

**Explanation:** The **DELETE DEFN TYPE(IMSIDMBR) FOR(IMSID(IMSX))** command deletes the IMS ID IMSX from the repository IMSID member table. The command is not successful, if the IMS IDIMSX is not defined in the IMSRSC repository.

**Example 8 for DELETE DEFN command**

TSO SPOC input:

```
DELETE DEFN TARGET(REPO) TYPE(LTERM) NAME(B0P06) FOR(IMSID(IMS1,IMS2))
```

TSO SPOC output:

```
(screen 1)
Response for: DELETE DEFN TARGET(REPO) TYPE(LTERM) NAME(B0P06)...
Name      Type      MbrName    CC CCText
IMS1      LIST      IMS1        0
IMS2      LIST      IMS1        1D3 REPOSITORY MEMBER NOT FOUND
B0P06     LTERM     IMS1        0
                                         IMS1
```

OM API input:

```
CMD(DEL TARGET(REPO) TYPE(LTERM) NAME(B0P06) FOR(IMSID(IMS1,IMS2))
```

OM API output:

```
<cmdrsphdr>
<hdr slbl="NAME" llbl="Name" scope="LCL" sort="a" key="2" scroll="no"
  len="8" dtype="CHAR" align="left" />
<hdr slbl="TYPE" llbl="Type" scope="LCL" sort="a" key="1" scroll="no"
  len="8" dtype="CHAR" align="left" />
<hdr slbl="MBR" llbl="MbrName" scope="LCL" sort="a" key="3" scroll="no"
  len="8" dtype="CHAR" align="left" />
<hdr slbl="CC" llbl="CC" scope="LCL" sort="n" key="0" scroll="yes"
  len="4" dtype="INT" align="right" />
<hdr slbl="CCTXT" llbl="CCText" scope="LCL" sort="n" key="0"
  scroll="yes" len="32" dtype="CHAR" align="left" skipb="yes" />
<hdr slbl="IMSID" llbl="IMSid" scope="LCL" sort="a" key="4" scroll="no"
  len="8" dtype="CHAR" align="left" skipb="yes" />
<hdr slbl="DTYP" llbl="DelType" scope="LCL" sort="n" key="1" scroll="no"
  len="8" dtype="CHAR" align="left" skipb="yes" />
</cmdrsphdr>
<cmdrspdata>
<rsp>NAME(IMS1 ) TYPE(LIST) MBR(IMS1) CC( 0) </rsp>
<rsp>NAME(IMS2 ) TYPE(LIST) MBR(IMS1) CC( 1D3) CCTXT(REPOSITORY
  MEMBER NOT FOUND) </rsp>
<rsp>NAME(B0P06 ) TYPE(LTERM) MBR(IMS1) CC( 0) IMSID(IMS1 )
</rsp>
</cmdrspdata>
```

**Explanation:** MSC remote LTERM is defined to IMS1 and the IMSRSC repository for IMS1, but it is not defined to IMS2 locally or in the repository. This **DELETE DEFN** command fails with a completion code for IMS2, but succeeds for IMS1. LTERM B0P06 is not found in the resource list for IMS2.

#### Related information

[DFS3406I \(Messages and Codes\)](#)

[DFS3407E \(Messages and Codes\)](#)

## DELETE IMSCON commands

Use the **DELETE IMSCON** commands to delete IMS Connect resource definitions during runtime processing without having to restart your IMS Connect instance.

The TYPE keyword specifies the type of IMS Connect resource to delete.

The **DELETE IMSCON** command is processed by every IMS Connect to which OM routes the command, whether or not OM has designated a particular IMS Connect as the command master.

IMS Connect resources that are deleted by use of this command will reappear after the next restart of IMS Connect, unless the corresponding configuration statement is also removed from the HWSCFGxx member of the IMS PROCLIB data set before the next restart.

Subsections:

- [“DELETE IMSCON TYPE\(DATASTORE\) command” on page 375](#)
- [“DELETE IMSCON TYPE\(IMSPLEX\) command” on page 380](#)
- [“DELETE IMSCON TYPE\(PORT\) command” on page 384](#)

#### Related reference

[IMS Connect type-2 commands \(Commands\)](#)

## DELETE IMSCON TYPE(DATASTORE) command

Use the **DELETE IMSCON TYPE(DATASTORE)** command to delete a communications path to an IMS data store in IMS Connect.

Subsections:

- [“Environment” on page 376](#)

- [“Syntax” on page 376](#)
- [“Keywords” on page 376](#)
- [“Usage notes” on page 376](#)
- [“Equivalent WTOR and z/OS commands” on page 378](#)
- [“Output fields” on page 377](#)
- [“Return, reason, and completion codes” on page 377](#)
- [“Examples” on page 378](#)

## Environment

The **DELETE IMSCON** command is applicable only to IMS Connect. To issue this command, the following conditions must be satisfied:

- IMS Connect must be active and configured to communicate with the Common Service Layer (CSL) Structured Call Interface (SCI).
- A type-2 command environment with Structured Call Interface (SCI) and Operations Manager (OM) must be active.

## Syntax



## Keywords

The following keywords are valid for the **DELETE IMSCON TYPE(DATASTORE)** command.

### NAME

Specifies the 1-8 character name of the IMS data store. The name can consist of alphanumeric characters and must be unique within IMS Connect.

This name is equivalent to the ID parameter of the DATASTORE statement in the IMS Connect configuration member.

Wildcards are supported in the name. This parameter is required.

## Usage notes

You can issue the **DELETE IMSCON TYPE(DATASTORE)** command only through the Operations Manager (OM) API.

IMS Connect can process IMS Connect type-2 commands only if the IMSplex from which the commands were issued has a status of ACTIVE.

The communications path to the IMS data store must be stopped (in NOTACTIVE status) before it can be deleted by use of the **DELETE IMSCON TYPE(DATASTORE)** command.

IMS Connect resources that are deleted by use of this command will reappear after the next restart of IMS Connect, unless the corresponding configuration statement is also removed from the HWSCFGxx member of the IMS PROCLIB data set before the next restart.

## Output fields

### Short label

Contains the short label that is generated in the XML output.

### Long label

Contains the column heading displayed on the TSO SPOC screen.

### Keyword

Identifies the keyword on the command that caused the field to be generated. N/A (not applicable) is displayed for output fields that are always returned. *error* is displayed for output fields that are returned only in the case of an error.

### Meaning

Provides a brief description of the output field.

Table 194. Output fields for the DELETE IMSCON TYPE(DATASTORE) command

| Short label | Long label | Keyword | Meaning  |
|-------------|------------|---------|--|
| CC          | CC         | N/A     | Completion code that indicates whether IMS Connect was able to process the command for the specified resource. The completion code is always returned. See <a href="#">Table 196 on page 378</a> . |
| CCTXT       | CCText     | N/A     | Completion code text that briefly explains the meaning of the nonzero completion code. This field is returned only for an error completion code.   |
| DS          | DataStore  | N/A     | The data store name. The data store name is always returned.   |
| MBR         | MbrName    | N/A     | Identifier of the IMS Connect that built the output line. The identifier is always returned.   |

## Return, reason, and completion codes

The return and reason codes that can be returned as a result of the **DELETE IMSCON TYPE (DATASTORE)** command are standard for all commands entered through the OM API.

The following table includes the return and reason codes and a brief explanation of the codes. The return or reason code returned for the command might also indicate an error from a CSL request.

Table 195. Return and reason codes for the DELETE IMSCON TYPE(DATASTORE) command

| Return code | Reason code | Meaning  |
|-------------|-------------|--|
| X'00000000' | X'00000000' | The <b>DELETE IMSCON TYPE (DATASTORE)</b> command completed successfully. The command output contains a line for each resource, accompanied by its completion code. For details, see <a href="#">Table 196 on page 378</a> . |
| X'0C00000C' | X'00003000' | The command was successful for some resources but failed for others. The command output contains a line for each resource, accompanied by its completion code.   |
| X'0C00000C' | X'00003004' | The command was not successful for any resource. The command output contains a line for each resource, accompanied by its completion code.   |

Errors unique to the processing of this command are returned as completion codes. A completion code is returned for each action against an individual resource.

Table 196. Completion codes for the DELETE IMSCON TYPE(DATASTORE) command

| Completion code | Completion code text    | Meaning  |
|-----------------|-------------------------|--|
| 0               |                         | The <b>DELETE IMSCON TYPE(DATASTORE)</b> command completed successfully for the resources. |
| 10              | No resources found      | The data store was not found.  |
| 14              | Resource is not stopped | The resource is not stopped. To delete this resource, it must be stopped first.            |

## Equivalent WTOR and z/OS commands

There are no equivalent WTOR and IMS Connect z/OS commands that perform similar functions as the **DELETE IMSCON TYPE(DATASTORE)** command.

## Examples

### Example 1 for DELETE IMSCON TYPE(DATASTORE) command

TSO SPOC input:

```
DELETE IMSCON TYPE(DATASTORE) NAME(IMS1)
```

TSO SPOC output:

```
DataStore MbrName      CC
IMS1      HWS1          0
```

OM API input:

```
CMD(DEL IMSCON TYPE(DATASTORE) NAME(IMS1))
```

OM API output:

```
<?xml version="1.0"?>
<!DOCTYPE imsout SYSTEM "imsout.dtd">
<imsout>
<ctl>
<omname>OM10M </omname>
<omvsn>1.7.0</omvsn>
<xmlvsn>20 </xmlvsn>
<statime>2014.064 18:26:57.848593</statime>
<stotime>2014.064 18:26:57.848849</stotime>
<staseq>CCCF07338D111E45</staseq>
<stoseq>CCCF07338D211145</stoseq>
<rqsttkn1>USRT011 10102657</rqsttkn1>
<rc>00000000</rc>
<rsn>00000000</rsn>
</ctl>
<cmd>
<master>HWS1 </master>
<userid>USRT011 </userid>
<verb>DEL </verb>
<kwd>IMSCON </kwd>
<input>DELETE IMSCON TYPE(DATASTORE) NAME(IMS1) </input>
</cmd>
<cmdsphdr>
<hdr slbl="DS" llbl="DataStore" scope="LCL" sort="a" key="1"
scroll="no" len="8" dtype="CHAR" align="left" skipb="no" />
<hdr slbl="MBR" llbl="MbrName" scope="LCL" sort="a" key="2"
scroll="no" len="8" dtype="CHAR" align="left" skipb="no" />
<hdr slbl="CC" llbl="CC" scope="LCL" sort="n" key="0" scroll="yes"
len="4" dtype="INT" align="right" skipb="no" />
<hdr slbl="CCTXT" llbl="CCText" scope="LCL" sort="n" key="0"
```

```

    scroll="yes" len="32" dtype="CHAR" align="left" skipb="yes" />
</cmdrsphdr>
<cmdrspdata>
<rsp>DS(IMS1      ) MBR(HWS1              ) CC(    0) </rsp>
</cmdrspdata>
</imsout>

```

**Explanation:** The communications to IMS data store IMS1 is deleted.

### Example 2 for DELETE IMSCON TYPE(DATASTORE) command

TSO SPOC input:

```
DELETE IMSCON TYPE(DATASTORE) NAME(IM*,SYS3,ABC1)
```

TSO SPOC output:

| DataStore | MbrName | CC | CCText                  |
|-----------|---------|----|-------------------------|
| ABC1      | HWS1    | 10 | No resources found      |
| IMS1      | HWS1    | 0  |                         |
| IMS2      | HWS1    | 0  |                         |
| SYS3      | HWS1    | 14 | Resource is not stopped |

OM API input:

```
CMD(DEL IMSCON TYPE(DATASTORE) NAME(IM*,SYS3,ABC1))
```

OM API output:

```

<?xml version="1.0"?>
<!DOCTYPE imsout SYSTEM "imsout.dtd">
<imsout>
<ctl>
<omname>OM10M </omname>
<omvsn>1.7.0</omvsn>
<xmlvsn>20 </xmlvsn>
<statime>2014.064 18:42:19.322200</statime>
<stotime>2014.064 18:42:19.322450</stotime>
<staseq>CCCF0AA256358E43</staseq>
<stoseq>CCCF0AA256452943</stoseq>
<rqsttkn1>USRT011 10104219</rqsttkn1>
<rc>0200000C</rc>
<rsn>00003008</rsn>
<rsnmsg>CSLN054I</rsnmsg>
<rsntxt>None of the clients were successful.</rsntxt>
</ctl>
<cmderr>
<mbr name="HWS1      ">
<typ>IMSCON </typ>
<rc>0C00000C</rc>
<rsn>00003000</rsn>
<rsntxt>At least one request successful </rsntxt>
</mbr>
</cmderr>
<cmd>
<master>HWS1 </master>
<userid>USRT011 </userid>
<verb>DEL </verb>
<kwd>IMSCON </kwd>
<input>DELETE IMSCON TYPE(DATASTORE) NAME(IM*,SYS3,ABC1) </input>
</cmd>
<cmdrsphdr>
<hdr slbl="DS" llbl="DataStore" scope="LCL" sort="a" key="1"
  scroll="no" len="8" dtype="CHAR" align="left" skipb="no" />
<hdr slbl="MBR" llbl="MbrName" scope="LCL" sort="a" key="2"
  scroll="no" len="8" dtype="CHAR" align="left" skipb="no" />
<hdr slbl="CC" llbl="CC" scope="LCL" sort="n" key="0" scroll="yes"
  len="4" dtype="INT" align="right" skipb="no" />
<hdr slbl="CCTXT" llbl="CCText" scope="LCL" sort="n" key="0"
  scroll="yes" len="32" dtype="CHAR" align="left" skipb="yes" />
</cmdrsphdr>
<cmdrspdata>
<rsp>DS(IMS1      ) MBR(HWS1              ) CC(    0) </rsp>
<rsp>DS(IMS2      ) MBR(HWS1              ) CC(    0) </rsp>
<rsp>DS(SYS3      ) MBR(HWS1              ) CC(   14) CCTXT(Resource is
  not stopped) </rsp>

```

```
<isp>DS(ABC1 ) MBR(HWS1 ) CC( 10) CCTXT(No resources
found) </isp>
</cmdrspdata>
</imsout>
```

**Explanation:** All communications to IMS data store that start with characters "IM" are deleted. IMS data store SYS3 cannot be deleted because it was not stopped. IMS data store ABC1 could not be found.

### Related reference

[CSLOMCMO: command request \(System Programming APIs\)](#)

[IMSPLEX statement \(System Definition\)](#)

[DATASTORE statement \(System Definition\)](#)

## DELETE IMSCON TYPE(IMSPLEX) command

Use the **DELETE IMSCON TYPE(IMSPLEX)** command to delete a communications path to an IMSplex in IMS Connect.

Subsections:

- [“Environment” on page 380](#)
- [“Syntax” on page 380](#)
- [“Keywords” on page 380](#)
- [“Usage notes” on page 381](#)
- [“Equivalent WTOR and z/OS commands” on page 382](#)
- [“Output fields” on page 381](#)
- [“Return, reason, and completion codes” on page 381](#)
- [“Examples” on page 383](#)

### Environment

The **DELETE IMSCON** command is applicable only to IMS Connect. To issue this command, the following conditions must be satisfied:

- IMS Connect must be active and configured to communicate with the Common Service Layer (CSL) Structured Call Interface (SCI).
- A type-2 command environment with Structured Call Interface (SCI) and Operations Manager (OM) must be active.

### Syntax

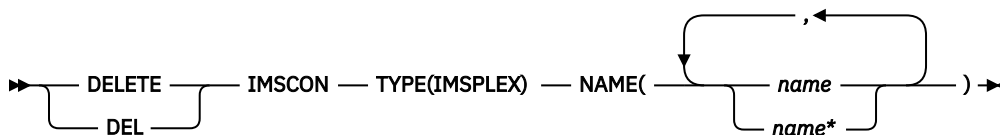

### Keywords

The following keywords are valid for the **DELETE IMSCON TYPE(IMSPLEX)** command.

#### NAME

Specifies a 1- to 5-character name of the IMSplex.

This name is equivalent to the TMEMBER parameter of the IMSPLEX statement in the IMS Connect configuration member.



Wildcards are supported in the name. This parameter is required.

## Usage notes

You can issue the **DELETE IMSCON TYPE(IMSPLEX)** command only through the Operations Manager (OM) API.

IMS Connect can process IMS Connect type-2 commands only if the IMSplex from which the commands were issued has a status of ACTIVE.

The communications path to the IMSplex must be stopped (in NOT ACTIVE state) before it can be deleted by use of the **DELETE IMSCON TYPE(IMSPLEX)** command.

IMS Connect communicates with an IMSplex to receive and respond to type-2 command requests. For this reason, you cannot use the **DELETE** command to delete the IMSplex that IMS Connect uses for type-2 command processing. When NAME(\*) is specified on the **DELETE** command, communications paths to all IMSplex systems are deleted except for the IMSplex that is used for type-2 command processing.

If the IMSplex is used by another resource such as MSC, ISC, or ODBM, the IMSplex cannot be deleted.

IMS Connect resources that are deleted by use of this command will reappear after the next restart of IMS Connect, unless the corresponding configuration statement is also removed from the HWSCFGxx member of the IMS PROCLIB data set before the next restart.

## Output fields

### Short label

Contains the short label that is generated in the XML output.

### Long label

Contains the column heading displayed on the TSO SPOC screen.

### Keyword

Identifies the keyword on the command that caused the field to be generated. N/A (not applicable) is displayed for output fields that are always returned. *error* is displayed for output fields that are returned only in the case of an error.

### Meaning

Provides a brief description of the output field.

Table 197. Output fields for the **DELETE IMSCON TYPE(IMSPLEX)** command

| Short label | Long label | Keyword | Meaning  |
|-------------|------------|---------|--|
| CC          | CC         | N/A     | Completion code that indicates whether IMS Connect was able to process the command for the specified resource. The completion code is always returned. See <a href="#">Table 199 on page 382</a> . |
| CCTXT       | CCText     | N/A     | Completion code text that briefly explains the meaning of the nonzero completion code. This field is returned only for an error completion code.   |
| IMSPLX      | IMSplex    | N/A     | The IMSplex name. The IMSplex name is always returned.   |
| MBR         | MbrName    | N/A     | Identifier of the IMS Connect that built the output line. The identifier is always returned.   |

## Return, reason, and completion codes

The return and reason codes that can be returned as a result of the **DELETE IMSCON TYPE(IMPSPLEX)** command are standard for all commands that are entered through the OM API.

The following table includes the return and reason codes and a brief explanation of the codes. The return or reason code returned for the command might also indicate an error from a CSL request.

*Table 198. Return and reason codes for the DELETE IMSCON TYPE(IMPSPLEX) command*

| Return code | Reason code | Meaning   |
|-------------|-------------|---|
| X'00000000' | X'00000000' | The <b>DELETE IMSCON TYPE(IMPSPLEX)</b> command completed successfully. The command output contains a line for each resource, accompanied by its completion code. For details, see Table 199 on page 382. |
| X'0C000008' | X'00002018' | The required NAME parameter is not specified.   |
| X'0C00000C' | X'00003000' | The command was successful for some resources but failed for others. The command output contains a line for each resource, accompanied by its completion code.  |
| X'0C00000C' | X'00003004' | The command was not successful for any resource. The command output contains a line for each resource, accompanied by its completion code.  |

Errors unique to the processing of this command are returned as completion codes. A completion code is returned for each action against an individual resource.

*Table 199. Completion codes for the DELETE IMSCON TYPE(IMPSPLEX) command*

| Completion code | Completion code text             | Meaning   |
|-----------------|----------------------------------|---|
| 0               |                                  | The <b>DELETE IMSCON TYPE(IMPSPLEX)</b> command completed successfully for the resources. |
| 10              | No resources found               | The IMSplex was not found.  |
| 14              | Resource is not stopped          | The resource is not stopped. To delete this resource, it must be stopped first.           |
| 41              | NAME value is too long           | The specified NAME value is too long. IMSplex name is maximum of 5 characters.            |
| 45              | Cmd processing uses this IMSplex | The IMSplex that IMS Connect uses to process this command cannot be deleted.              |
| 46              | ODBM requires this IMSplex       | The IMSplex that is used for ODBM communications cannot be deleted.                       |
| 47              | MSC requires this IMSplex        | The IMSplex that is used for MSC communications cannot be deleted.                        |
| 48              | ISC requires this IMSplex        | The IMSplex that is used for ISC communications cannot be deleted.                        |

## Equivalent WTOR and z/OS commands

There are no equivalent WTOR and IMS Connect z/OS commands that perform similar functions as the **DELETE IMSCON TYPE(IMPSPLEX)** command.

## Examples

### Example 1 for DELETE IMSCON TYPE(IMSPLEX) command

TSO SPOC input:

```
DELETE IMSCON TYPE(IMSPLEX) NAME(PLEX2)
```

TSO SPOC output:

| IMSpIex | MbrName | CC |
|---------|---------|----|
| PLEX2   | HWS1    | 0  |

OM API input:

```
CMD(DEL IMSCON TYPE(IMSPLEX) NAME(PLEX2))
```

OM API output:

```
<?xml version="1.0"?>
<!DOCTYPE imsout SYSTEM "imsout.dtd">
<imsout>
<ctl>
<omname>OM10M </omname>
<omvsn>1.7.0</omvsn>
<xmlvsn>20 </xmlvsn>
<statime>2014.227 20:45:11.305908</statime>
<stotime>2014.227 20:45:11.306154</stotime>
<staseq>CD9C161AF0EB4E45</staseq>
<stoseq>CD9C161AF0FAA045</stoseq>
<rqsttkn1>USRT011 10134511</rqsttkn1>
<rc>00000000</rc>
<rsn>00000000</rsn>
</ctl>
<cmd>
<master>HWS1 </master>
<userid>USRT011 </userid>
<verb>DEL </verb>
<kwd>IMSCON </kwd>
<input>DELETE IMSCON TYPE(IMSPLEX) NAME(PLEX2) </input>
</cmd>
<cmdsphdr>
<hdr slbl="IMSPLEX" llbl="IMSpIex" scope="LCL" sort="a" key="1" scroll="no"
len="8" dtype="CHAR" align="left" skipb="no" />
<hdr slbl="MBR" llbl="MbrName" scope="LCL" sort="a" key="2" scroll="no"
len="8" dtype="CHAR" align="left" skipb="no" />
<hdr slbl="CC" llbl="CC" scope="LCL" sort="n" key="0" scroll="yes" len="4"
dtype="INT" align="right" skipb="no" />
<hdr slbl="CCTXT" llbl="CCText" scope="LCL" sort="n" key="0" scroll="yes"
len="32" dtype="CHAR" align="left" skipb="yes" />
</cmdsphdr>
<cmdsphdata>
<rsp>IMSPLEX( PLEX2 ) MBR(HWS1 ) CC( 0) </rsp>
</cmdsphdata>
</imsout>
```

**Explanation:** The communication path to IMSplex PLEX2 is deleted.

### Example 2 for DELETE IMSCON TYPE(IMSPLEX) command

TSO SPOC input:

```
DELETE IMSCON TYPE(IMSPLEX) NAME(PLEX*)
```

TSO SPOC output:

| IMSpIex | MbrName | CC | CCText                           |
|---------|---------|----|----------------------------------|
| PLEX1   | HWS1    | 45 | Cmd processing uses this IMSplex |
| PLEX2   | HWS1    | 0  |                                  |
| PLEX3   | HWS1    | 14 | Resource is not stopped          |
| PLEX4   | HWS1    | 46 | ODBM requires this IMSplex       |

OM API input:

```
CMD(DELETE IMSCON TYPE(IMSPLEX) NAME(PLEX*))
```

OM API output:

```
<?xml version="1.0"?>
<!DOCTYPE imsout SYSTEM "imsout.dtd">
<imsout>
<ctl>
<omname>OM10M </omname>
<omvsn>1.7.0</omvsn>
<xmlvsn>20 </xmlvsn>
<stime>2014.227 21:10:58.581664</stime>
<stotime>2014.227 21:10:58.581933</stotime>
<staseq>CD9C1BDE89CA05C0</staseq>
<stoseq>CD9C1BDE89DADD0</stoseq>
<rqsttkn1>USRT011 10141058</rqsttkn1>
<rc>0200000C</rc>
<rsn>00003008</rsn>
<rsnmsg>CSLN054I</rsnmsg>
<rsntxt>None of the clients were successful.</rsntxt>
</ctl>
<cmderr>
<mbr name="HWS1 ">
<typ>IMSCON </typ>
<rc>0C00000C</rc>
<rsn>00003000</rsn>
<rsntxt>At least one request successful </rsntxt>
</mbr>
</cmderr>
<cmd>
<master>HWS1 </master>
<userid>USRT011 </userid>
<verb>DEL </verb>
<kwd>IMSCON </kwd>
<input>DELETE IMSCON TYPE(IMSPLEX) NAME(PLEX*) </input>
</cmd>
<cmdrsphdr>
<hdr slbl="IMSPLEX" llbl="IMSpIex" scope="LCL" sort="a" key="1" scroll="no"
len="8" dtype="CHAR" align="left" skipb="no" />
<hdr slbl="MBR" llbl="MbrName" scope="LCL" sort="a" key="2" scroll="no"
len="8" dtype="CHAR" align="left" skipb="no" />
<hdr slbl="CC" llbl="CC" scope="LCL" sort="n" key="0" scroll="yes" len="4"
dtype="INT" align="right" skipb="no" />
<hdr slbl="CCTXT" llbl="CCText" scope="LCL" sort="n" key="0" scroll="yes"
len="32" dtype="CHAR" align="left" skipb="yes" />
</cmdrsphdr>
<cmdrspdata>
<rsp>IMSPLEX( PLEX1 ) MBR(HWS1 ) CC( 45) CCTXT(Cmd processing
uses this IMSpIex) </rsp>
<rsp>IMSPLEX( PLEX2 ) MBR(HWS1 ) CC( 0) </rsp>
<rsp>IMSPLEX( PLEX3 ) MBR(HWS1 ) CC( 14) CCTXT(Resource is not
stopped) </rsp>
<rsp>IMSPLEX( PLEX4 ) MBR(HWS1 ) CC( 46) CCTXT(ODBM requires
this IMSpIex) </rsp>
</cmdrspdata>
</imsout>
```

**Explanation:** The command is attempting to delete all communication paths to IMSplex systems that start with the characters 'PLEX'. IMSplex PLEX1 cannot be deleted because it is the IMSplex used to send this command. IMSplex PLEX2 was deleted. IMSplex PLEX3 cannot be deleted because it is not stopped. IMSplex PLEX4 cannot be deleted because communication to ODBM requires that IMSplex.

## DELETE IMSCON TYPE(PORT) command

Use the **DELETE IMSCON TYPE(PORT)** command to delete a listening port in IMS Connect.

This command cannot be used to delete SSL or LOCAL ports.

Subsections:

- [“Environment” on page 385](#)
- [“Syntax” on page 385](#)



### Keyword

Identifies the keyword on the command that caused the field to be generated. N/A (not applicable) is displayed for output fields that are always returned. *error* is displayed for output fields that are returned only in the case of an error.

### Meaning

Provides a brief description of the output field.

Table 200. Output fields for the **DELETE IMSCON TYPE(PORT)** command

| Short label | Long label | Keyword | Meaning  |
|-------------|------------|---------|--|
| CC          | CC         | N/A     | Completion code that indicates whether IMS Connect was able to process the command for the specified resource. The completion code is always returned. See <a href="#">Table 202 on page 386</a> . |
| CCTXT       | CCText     | N/A     | Completion code text that briefly explains the meaning of the nonzero completion code. This field is returned only for an error completion code.   |
| MBR         | MbrName    | N/A     | Identifier of the IMS Connect that built the output line. The identifier is always returned.   |
| PORT        | Port       | N/A     | The port number of the listening port to be deleted.   |

### Return, reason, and completion codes

The return and reason codes that can be returned as a result of the **DELETE IMSCON TYPE(PORT)** command are standard for all commands that are entered through the OM API.

The following table includes the return and reason codes and a brief explanation of the codes. The return or reason code returned for the command might also indicate an error from a CSL request.

Table 201. Return and reason codes for the **DELETE IMSCON TYPE(PORT)** command

| Return code | Reason code | Meaning  |
|-------------|-------------|--|
| X'00000000' | X'00000000' | The <b>DELETE IMSCON TYPE(PORT)</b> command completed successfully. The command output contains a line for each resource, accompanied by its completion code. For details, see <a href="#">Table 202 on page 386</a> . |
| X'0C00000C' | X'00003000' | The command was successful for some resources but failed for others. The command output contains a line for each resource, accompanied by its completion code.   |
| X'0C00000C' | X'00003004' | The command was not successful for any resource. The command output contains a line for each resource, accompanied by its completion code.   |

Errors unique to the processing of this command are returned as completion codes. A completion code is returned for each action against an individual resource.

Table 202. Completion codes for the **DELETE IMSCON TYPE(PORT)** command

| Completion code | Completion code text | Meaning   |
|-----------------|----------------------|---|
| 0               |                      | The <b>DELETE IMSCON TYPE(PORT)</b> command completed successfully for the resources. |

Table 202. Completion codes for the DELETE IMSCON TYPE(PORT) command (continued)

| Completion code | Completion code text    | Meaning   |
|-----------------|-------------------------|---|
| 10              | No resources found      | The port number is unknown to the client that is processing the request. The port number might have been typed in error or it might not be active at this time. If a wildcard was specified in the command, there were no matches for the name. |
| 14              | Resource is not stopped | The resource is not stopped. To delete this resource, it must be stopped first.   |
| 3B              | Port type is invalid    | The port type is invalid. SSL and local ports cannot be specified.  |

## Equivalent WTOR and z/OS commands

There are no equivalent WTOR and IMS Connect z/OS commands that perform similar functions as the **DELETE IMSCON TYPE(PORT)** command.

## Examples

### Example 1 for DELETE IMSCON TYPE(PORT) command

TSO SPOC input:

```
DELETE IMSCON TYPE(PORT) NAME(8888)
```

TSO SPOC output:

```
Port      MbrName      CC
8888     HWS1         0
```

OM API input:

```
CMD(DEL IMSCON TYPE(PORT) NAME(8888))
```

OM API output:

```
<?xml version="1.0"?>
<!DOCTYPE imsout SYSTEM "imsout.dtd">
<imsout>
<ctl>
<omname>OM10M </omname>
<omvsn>1.7.0</omvsn>
<xmlvsn>20 </xmlvsn>
<statime>2013.283 22:48:48.511504</statime>
<stotime>2013.283 22:48:48.511747</stotime>
<stoseq>CC17B16D1C21084E</stoseq>
<stoseq>CC17B16D1C3030CE</stoseq>
<rqsttkn1>USRT011 10154848</rqsttkn1>
<rc>00000000</rc>
<rsn>00000000</rsn>
</ctl>
<cmd>
<master>HWS1 </master>
<userid>USRT011 </userid>
<verb>DEL </verb>
<kwd>IMSCON </kwd>
<input>DELETE IMSCON TYPE(PORT) NAME(8888) </input>
</cmd>
<cmdsphdr>
<hdr slbl="PORT" llbl="Port" scope="LCL" sort="a" key="1" scroll="no"
```

```

len="8" dtype="CHAR" align="left" skipb="no" />
<hdr slbl="MBR" llbl="MbrName" scope="LCL" sort="a" key="2" scroll="no"
len="8" dtype="CHAR" align="left" skipb="no" />
<hdr slbl="CC" llbl="CC" scope="LCL" sort="n" key="0" scroll="yes"
len="4" dtype="INT" align="right" skipb="no" />
<hdr slbl="CCTXT" llbl="CCText" scope="LCL" sort="n" key="0"
scroll="yes" len="32" dtype="CHAR" align="left" skipb="yes" />
</cmdrpsphdr>
<cmdrspdata>
<rsp>PORT(8888 ) MBR(HWS1 ) CC( 0) </rsp>
</cmdrspdata>
</imsout>

```

**Explanation:** Port 8888 is deleted.

### Example 2 for DELETE IMSCON TYPE(PORT) command

TSO SPOC input:

```
DELETE IMSCON TYPE(PORT) NAME(8*,9999,7777)
```

TSO SPOC output:

| Port | MbrName | CC | CCText                  |
|------|---------|----|-------------------------|
| 7777 | HWS1    | 10 | No resources found      |
| 8    | HWS1    | 0  |                         |
| 8123 | HWS1    | 14 | Resource is not stopped |
| 845  | HWS1    | 0  |                         |
| 86   | HWS1    | 0  |                         |
| 8888 | HWS1    | 0  |                         |
| 9999 | HWS1    | 0  |                         |

OM API input:

```
CMD(DEL IMSCON TYPE(PORT) NAME(8*,9999,7777))
```

OM API output:

```

<?xml version="1.0"?>
<!DOCTYPE imsout SYSTEM "imsout.dtd">
<imsout>
<ctl>
<omname>OM10M </omname>
<omvsn>1.7.0</omvsn>
<xmlvsn>20 </xmlvsn>
<statime>2013.283 22:55:36.537337</statime>
<stotime>2013.283 22:55:36.537599</stotime>
<staseq>CC17B2F23BCF9842</staseq>
<stoseq>CC17B2F23BDF242</stoseq>
<rqsttkn1>USRT011 10155536</rqsttkn1>
<rc>0200000C</rc>
<rsn>00003008</rsn>
<rsnmsg>CSLN054I</rsnmsg>
<rsntxt>None of the clients were successful.</rsntxt>
</ctl>
<cmderr>
<mbr name="HWS1 ">
<typ>IMSCON </typ>
<rc>0C00000C</rc>
<rsn>00003000</rsn>
<rsntxt>At least one request successful </rsntxt>
</mbr>
</cmderr>
<cmd>
<master>HWS1 </master>
<userid>USRT011 </userid>
<verb>DEL </verb>
<kwd>IMSCON </kwd>
<input>DELETE IMSCON TYPE(PORT) NAME(8*,9999,7777) </input>
</cmd>
<cmdrpsphdr>
<hdr slbl="PORT" llbl="Port" scope="LCL" sort="a" key="1" scroll="no"
len="8" dtype="CHAR" align="left" skipb="no" />
<hdr slbl="MBR" llbl="MbrName" scope="LCL" sort="a" key="2" scroll="no"
len="8" dtype="CHAR" align="left" skipb="no" />
<hdr slbl="CC" llbl="CC" scope="LCL" sort="n" key="0" scroll="yes"

```



```

len="4" dtype="INT" align="right" skipb="no" />
<hdr slbl="CCTXT" llbl="CCText" scope="LCL" sort="n" key="0"
scroll="yes" len="32" dtype="CHAR" align="left" skipb="yes" />
</cmdrsphdr>
<cmdrspdata>
<rsp>PORT(8888 ) MBR(HWS1 ) CC( 0) </rsp>
<rsp>PORT(8123 ) MBR(HWS1 ) CC( 14) CCTXT(Resource is
not stopped) </rsp>
<rsp>PORT(845 ) MBR(HWS1 ) CC( 0) </rsp>
<rsp>PORT(86 ) MBR(HWS1 ) CC( 0) </rsp>
<rsp>PORT(8 ) MBR(HWS1 ) CC( 0) </rsp>
<rsp>PORT(9999 ) MBR(HWS1 ) CC( 0) </rsp>
<rsp>PORT(7777 ) MBR(HWS1 ) CC( 10) CCTXT(No resources
found) </rsp>
</cmdrspdata>
</imsout>

```

**Explanation:** All ports whose port numbers start with 8 are deleted, except for 8123. Port 8123 cannot be deleted because it was not stopped. Port 9999 is also deleted. Port 7777 could not be found.

### Related reference

[CSLOMCMMD: command request \(System Programming APIs\)](#)

[IMS Connect Port Message Edit exit routine \(Exit Routines\)](#)

[IMSPLEX statement \(System Definition\)](#)

[ODACCESS statement \(System Definition\)](#)

[TCPIP statement \(System Definition\)](#)

## DELETE LE command

Use the **DELETE** command (with the LE keyword) to delete Language Environment (LE) runtime options that have previously been defined by the **UPDATE** command (with the LE keyword).

Subsections:

- [“Environment” on page 389](#)
- [“Syntax” on page 390](#)
- [“Keywords” on page 390](#)
- [“Usage notes” on page 390](#)
- [“Output fields” on page 391](#)
- [“Return, reason, and completion codes” on page 391](#)
- [“Examples” on page 392](#)

### Environment

The following table lists the environments (DB/DC, DBCTL, and DCCTL) in which you can use the command and keywords.

*Table 203. Valid environments for the DELETE command and keywords*

| Command / Keywords | DB/DC | DBCTL | DCCTL |
|--------------------|-------|-------|-------|
| <b>DELETE LE</b>   | X     | X     | X     |
| LTERM              | X     | X     | X     |
| PGM                | X     | X     | X     |
| TRAN               | X     | X     | X     |
| USERID             | X     | X     | X     |

## Syntax

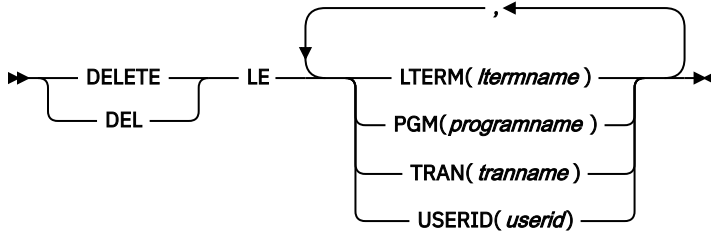

## Keywords

### LTERM()

Specifies the 1 - 8 character name of the LTERMs that match the generic or wildcard parameter.

### PGM()

Specifies the 1 - 8 character name of the programs that match the generic or wildcard parameter.

### TRAN()

Specifies the 1 - 8 character name of the transactions that match the generic or wildcard parameter.

### USERID()

Specifies the 1 - 8 character name of the user IDs that match the generic or wildcard parameter.

## Usage notes

The delete can use filters on transaction code, LTERM name, user ID, or program name. Any combination of parameters can be used to qualify the application instance to which the runtime parameters are deleted. All matches found are deleted. The entry is logically deleted. The entry is then immediately available for reuse by the next **UPDATE LE** command. There is a small window of time where it is possible for an entry to be deleted and reused before LE uses it, that could cause LE to use the wrong set of parameters.

This command may be specified only through the Operations Manager API. The command syntax for this command is defined in XML and is available to automation programs that communicate with OM.

OM overrides the routing on the command and routes the command to all IMS systems in the IMSplex. The user-specified route list is ignored.

Rules for matching an entry which results in the delete of an entry:

- If a filter is specified in the command for a particular resource it must match the resource filter defined in the entry. The resource in the **DELETE LE** command can be specified with wildcards as defined previously.
- A resource filter that is not specified on a **DELETE LE** command will match on any filter for the specific resource defined in the entry. A non-specified filter is treated as a wildcard. For instance if the LTERM filter is not specified on a **DELETE LE** command it will match on any LTERM resource defined in an entry, as if LTERM(\*) was specified on the command.

If an existing set of LE runtime options are found for the specified TRAN, LTERM, USERID, or PGM, the existing parameter string is deleted. The string is deleted only when the specified filters are an exact match for the existing entry. The entry is logically deleted. The entry is available for reuse on the next **UPDATE LE** command.

The following keywords support a generic or wildcard character. A generic parameter is a 1 - 8 character alphanumeric name that includes one or more special characters and an asterisk or a percent sign. An asterisk can be replaced by a zero or more characters to create a valid resource name. A percent sign can be replaced by exactly one character to create a valid resource name.

**Requirement:** At least one of the resource filters (LTERM, PGM, TRAN, or USERID) must be specified on the **UPDATE LE** command.

## Output fields

The following table shows the output fields for an **DELETE LE** command. The columns in the table are as follows:

### Short label

Contains the short label generated in the XML output.

### Keyword

Identifies the keyword on the command that caused the field to be generated. N/A appears for output fields that are always returned.

### Meaning

Provides a brief description of the output field.

*Table 204. Output fields for the DELETE LE command*

| Short label | Keyword | Meaning   |
|-------------|---------|---|
| CC          | N/A     | Completion code for the line of output. Completion code is always returned.                 |
| LTRM        | LTERM   | LTERM name affected by the <b>DELETE</b> .  |
| MBR         | N/A     | IMSplex member (IMS identifier) that built the output line. Member name is always returned. |
| PGM         | PGM     | Program name affected by the <b>DELETE</b> .  |
| TRAN        | TRAN    | Transaction name affected by the <b>DELETE</b> .  |
| UID         | USERID  | Userid affected by the <b>DELETE</b> .  |

## Return, reason, and completion codes

The following table includes the return and reason codes and a brief explanation of the codes. The return or reason code returned for the command might also indicate an error from a CSL request.

*Table 205. Return and reason codes for the DELETE LE command*

| Return code | Reason code | Meaning  |
|-------------|-------------|--|
| X'00000000' | X'00000000' | The <b>DELETE LE</b> command completed successfully.   |
| X'00000008' | X'00002008' | No keywords were specified on the command. At least one keyword is required.                                     |
| X'00000008' | X'0000200C' | No resources found to delete. Either the entry was previously deleted or a keyword filter was typed incorrectly. |
| X'00000008' | X'00002014' | An invalid character was specified in the filter name.   |
| X'00000010' | X'00004040' | The parameter override header has not been initialized. Retry the command after restart is complete.             |
| X'00000014' | X'00005000' | Unable to get storage from IMODULE GETSTOR.  |
| X'00000014' | X'00005010' | Unable to obtain latch.  |
| X'00000014' | X'00005FFF' | Internal IMS Error - should not occur.   |

The following table contains the completion code that can be returned on a **DELETE LE** command and the meaning of the code.

*Table 206. Completion code for the DELETE LE command*

| Completion code | Meaning   |
|-----------------|---|
| 0               | The <b>DELETE LE</b> command completed successfully for the specified resource. |

### Examples

The following are examples of the **DELETE LE** command:

#### **Example 1 for DELETE LE command**

For this example, the following table shows the parameter override table entries prior to any **DELETE LE** commands being processed.

*Table 207. Parameter override table entries for DELETE LE example*

| Entry# | TRAN | LTERM | USERID  | PROGRAM  | LERUNOPTS |
|--------|------|-------|---------|----------|-----------|
| 1      | PART |       |         | DFSSAM02 | aaaa      |
| 2      | PART |       | BETTY   |          | bbbb      |
| 3      | PART | TERM1 |         |          | cccc      |
| 4      |      |       |         | DFSSAM02 | dddd      |
| 5      | PART | TERM1 | BARBARA |          | eeee      |
| 6      | PART | TERM1 | BOB     |          | ffff      |
| 7      |      | TERM2 | BETTY   |          | gggg      |
| 8      | PART | TERM2 |         |          | iiii      |

The following table shows the resulting actions when different filters are specified on a **DELETE LE** command.

*Table 208. Example filters and resulting actions for DELETE LE command*

| Filters active on command             | Resulting action                  |
|---------------------------------------|-----------------------------------|
| TRAN(PART)                            | Deletes entries #1, 2, 3, 5, 6, 8 |
| TRAN(PART) LTERM(TERM1)               | Deletes entries #3, 5, 6          |
| LTERM(TERM2) USERID(BETTY)            | Deletes entry #7                  |
| TRAN(PART) LTERM(TERM1) USERID(BETTY) | Does not delete any entries       |
| TRAN(PART) LTERM(TERM*)               | Deletes entries #3, 5, 6, 8       |
| USERID(B*)                            | Deletes entries #2, 5, 6, 7       |

#### **Example 2 for DELETE LE command**

The following TSO SPOC and OM API input and output sets up the scenario for the **DELETE LE** command examples. The **UPDATE** commands are used to add entries to the table; the **QUERY** command shows the resulting entries.

TSO SPOC input:

```

UPD LE TRAN(IAPMDI27) USERID(USRT003) SET(LERUNOPTS(cccc))
UPD LE TRAN(IAPMDI27) USERID(USRID01) SET(LERUNOPTS(bbbb))
UPD LE TRAN(IAPMDI26) USERID(USRID01) SET(LERUNOPTS(aaaa))
QRY LE SHOW(ALL)

```

TSO SPOC output (for **QUERY** command):

| MbrName | CC | Trancode | Lterm | Userid  | Program | LERunOpts |
|---------|----|----------|-------|---------|---------|-----------|
| SYS3    | 0  | IAPMDI26 |       | USRID01 |         | AAAA      |
| SYS3    | 0  | IAPMDI27 |       | USRID01 |         | BBBB      |
| SYS3    | 0  | IAPMDI27 |       | USRT003 |         | CCCC      |

OM API input:

```

CMD(UPD LE TRAN(IAPMDI27) USERID(USRT003) SET(LERUNOPTS(cccc)))
CMD(UPD LE TRAN(IAPMDI27) USERID(USRID01) SET(LERUNOPTS(bbbb)))
CMD(UPD LE TRAN(IAPMDI26) USERID(USRID01) SET(LERUNOPTS(aaaa)))
CMD(QRY LE SHOW(ALL))

```

OM API output (for **QUERY** command):

```

<imsout>
<ctl>
<omname>OM10M </omname>
<omvsn>1.1.0</omvsn>
<xmlvsn>1 </xmlvsn>
<statime>2002.163 18:10:14.974557</statime>
<stotime>2002.163 18:10:14.974985</stotime>
<staseq>B7C4CD747AC5DC85</staseq>
<stoseq>B7C4CD747AE09D25</stoseq>
<rqsttkn1>USRT002 10111014</rqsttkn1>
<rc>00000000</rc>
<rsn>00000000</rsn>
</ctl>
<cmd>
<master>SYS3 </master>
<userid>USRT002 </userid>
<verb>QRY </verb>
<kwd>LE </kwd>
<input>QRY LE SHOW(ALL) </input>
</cmd>
<cmdrsphdr>
<hdr slbl="MBR" llbl="MbrName" scope="LCL" sort="A" key="1" scroll="NO" len="8"
  dtype="CHAR" align="left" />
<hdr slbl="CC" llbl="CC" scope="LCL" sort="N" key="0" scroll="YES" len="4"
  dtype="INT" align="right" />
<hdr slbl="TRAN" llbl="Trancode" scope="LCL" sort="N" key="0" scroll="YES" len="8"
  dtype="CHAR" align="left" />
<hdr slbl="LTRM" llbl="Lterm" scope="LCL" sort="N" key="0" scroll="YES" len="8"
  dtype="CHAR" align="left" />
<hdr slbl="UID" llbl="Userid" scope="LCL" sort="N" key="0" scroll="YES" len="8"
  dtype="CHAR" align="left" />
<hdr slbl="PGM" llbl="Program" scope="LCL" sort="N" key="0" scroll="YES" len="8"
  dtype="CHAR" align="left" />
<hdr slbl="PRM" llbl="LERunOpts" scope="LCL" sort="N" key="0" scroll="YES" len="*"
  dtype="CHAR" align="left" />
</cmdrsphdr>
<cmdrspdata>
<rsp>MBR(SYS3 ) CC( 0) TRAN(IAPMDI26) LTRM( ) UID(USRID01 ) PGM( )
PRM(AAAA ) </rsp>
<rsp>MBR(SYS3 ) CC( 0) TRAN(IAPMDI27) LTRM( ) UID(USRID01 ) PGM( )
PRM(BBBB ) </rsp>
<rsp>MBR(SYS3 ) CC( 0) TRAN(IAPMDI27) LTRM( ) UID(USRT003 ) PGM( )
PRM(CCCC ) </rsp>
</cmdrspdata>
</imsout>

```

### Example 3 for DELETE LE command

TSO SPOC input:

```
DEL LE TRAN(IAPMDI27) USERID(USRID01)
```

TSO SPOC output:

| MbrName | CC | Trancode | Lterm | Userid  | Program |
|---------|----|----------|-------|---------|---------|
| SYS3    | 0  | IAPMDI27 |       | USRID01 |         |

OM API input:

```
CMD(DEL LE TRAN(IAPMDI27) USERID(USRID01))
```

OM API output:

```
<imsout>
<ctl>
<omname>OM10M </omname>
<omvsn>1.1.0</omvsn>
<xmlvsn>1 </xmlvsn>
<statime>2002.163 18:12:21.932813</statime>
<stotime>2002.163 18:12:21.933334</stotime>
<staseq>B7C4CDED8E70D786</staseq>
<stoseq>B7C4CDED8E916246</stoseq>
<rqsttkn1>USRT002 10111221</rqsttkn1>
<rc>00000000</rc>
<rsn>00000000</rsn>
</ctl>
<cmd>
<master>SYS3 </master>
<userid>USRT002 </userid>
<verb>DEL </verb>
<kwd>LE </kwd>
<input>DEL LE TRAN(IAPMDI27) USERID(USRID01) </input>
</cmd>
<cmdrsphdr>
<hdr slbl="MBR" llbl="MbrName" scope="LCL" sort="A" key="1" scroll="NO" len="8"
  dtype="CHAR" align="left" />
<hdr slbl="CC" llbl="CC" scope="LCL" sort="N" key="0" scroll="YES" len="4"
  dtype="INT" align="right" />
<hdr slbl="TRAN" llbl="Trancode" scope="LCL" sort="N" key="0" scroll="YES" len="8"
  dtype="CHAR" align="left" />
<hdr slbl="LTRM" llbl="Lterm" scope="LCL" sort="N" key="0" scroll="YES" len="8"
  dtype="CHAR" align="left" />
<hdr slbl="UID" llbl="Userid" scope="LCL" sort="N" key="0" scroll="YES" len="8"
  dtype="CHAR" align="left" />
<hdr slbl="PGM" llbl="Program" scope="LCL" sort="N" key="0" scroll="YES" len="8"
  dtype="CHAR" align="left" />
</cmdrsphdr>
<cmdrspdata>
<rsp>MBR(SYS3 ) CC( 0) TRAN(IAPMDI27) LTRM( ) UID(USRID01 ) PGM( )
</rsp>
</cmdrspdata>
</imsout>
```

Explanation: This command specifies two filters- transaction and userid. A table entry is deleted if both of these filters are defined and match what was specified in the command. This command deletes one entry from the table. That entry is shown in the command output.

#### **Example 4 for DELETE LE command**

TSO SPOC input:

```
DEL LE USERID(USRT00%)
```

TSO SPOC output:

| MbrName | CC | Trancode | Lterm | Userid  | Program |
|---------|----|----------|-------|---------|---------|
| SYS3    | 0  | IAPMDI26 |       | USRID01 |         |
| SYS3    | 0  | IAPMDI27 |       | USRT003 |         |

OM API input:

```
CMD(DEL LE USERID(USRT00%))
```

OM API output:

```
<imsout>
<ctl>
```

```

<omname>OM10M </omname>
<omvsn>1.1.0</omvsn>
<xmlvsn>1 </xmlvsn>
<statime>2002.163 18:19:45.616468</statime>
<stotime>2002.163 18:19:45.616972</stotime>
<staseq>B7C4CF94AFA54304</staseq>
<stoseq>B7C4CF94AFC4C704</stoseq>
<rqsttkn1>USRT002 10111945</rqsttkn1>
<rc>00000000</rc>
<rsn>00000000</rsn>
</ctl>
<cmd>
<master>SYS3 </master>
<userid>USRT002 </userid>
<verb>DEL </verb>
<kwd>LE </kwd>
<input>DEL LE USERID(USRT00%) </input>
</cmd>
<cmdrsphdr>
<hdr slbl="MBR" llbl="MbrName" scope="LCL" sort="A" key="1" scroll="NO" len="8"
  dtype="CHAR" align="left" />
<hdr slbl="CC" llbl="CC" scope="LCL" sort="N" key="0" scroll="YES" len="4"
  dtype="INT" align="right" />
<hdr slbl="TRAN" llbl="Trancode" scope="LCL" sort="N" key="0" scroll="YES" len="8"
  dtype="CHAR" align="left" />
<hdr slbl="LTRM" llbl="Lterm" scope="LCL" sort="N" key="0" scroll="YES" len="8"
  dtype="CHAR" align="left" />
<hdr slbl="UID" llbl="Userid" scope="LCL" sort="N" key="0" scroll="YES" len="8"
  dtype="CHAR" align="left" />
<hdr slbl="PGM" llbl="Program" scope="LCL" sort="N" key="0" scroll="YES" len="8"
  dtype="CHAR" align="left" />
</cmdrsphdr>
<cmdrspdata>
<rsp>MBR(SYS3 ) CC( 0) TRAN(IAPMDI26) LTRM( ) UID(USRID01 ) PGM( )
</rsp>
<rsp>MBR(SYS3 ) CC( 0) TRAN(IAPMDI27) LTRM( ) UID(USRT003 ) PGM( )
</rsp>
</cmdrspdata>
</imsout>

```

Explanation: This command specifies only one filter, userid. A wildcard is used, so any table entry where the USERID filter matches the string will be deleted. The command output shows that both of the remaining table entries were deleted.

### Related concepts

How to interpret CSL request return and reason codes (System Programming APIs)

### Related reference

“Command keywords and their synonyms” on page 59

All IMS command keywords and their synonyms, as well as keywords supported by the OM API, are listed. The list covers command keywords for the OM command processing clients such as IMS, ODBM, IMSCON, and RM.

## DELETE LTERM command

Use the **DELETE LTERM** command to delete a Multiple Systems Coupling (MSC) remote LTERM.

Subsections:

- [“Environment” on page 396](#)
- [“Syntax” on page 396](#)
- [“Keywords” on page 396](#)
- [“Usage notes” on page 396](#)
- [“Output fields” on page 397](#)
- [“Return and reason codes” on page 397](#)
- [“Completion codes” on page 398](#)
- [“Examples” on page 399](#)

## Environment

The following table lists the environments (DB/DC, DBCTL, and DCCTL) in which you can use the command and keywords.

Table 209. Valid environments for the DELETE LTERM command and keywords

| Command / Keywords           | DB/DC | DBCTL | DCCTL |
|------------------------------|-------|-------|-------|
| DELETE LTERM NAME() OPTION() | X     |       | X     |

## Syntax

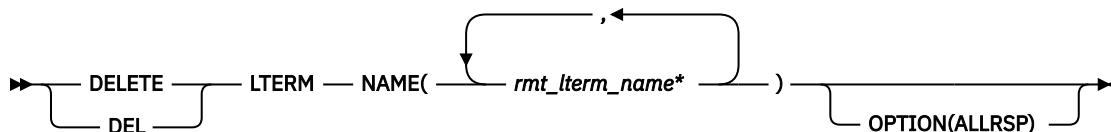

## Keywords

The following keywords are valid for the **DELETE LTERM** command:

### NAME

Specify one or more 1-8 character names of MSC remote LTERMs. Wildcards are supported in the name. Examples of valid names are NAME(\*) and NAME(abc\*). If the NAME parameter specified is a specific or wildcard name, command responses are returned for all the resource names that are processed. For NAME(\*), command responses are returned only for the resource names that resulted in an error. OPTION(ALLRSP) can be specified with NAME(\*) to obtain the command responses for all the resource names that are processed.

### OPTION

Specifies options for the command.

### ALLRSP

Indicates that the response lines are to be returned for all resources that are processed on the command. The default action is to return response lines only for the resources that resulted in an error. It is valid only with NAME(\*). ALLRSP is ignored for other NAME values.

## Usage notes

This command can be issued only through the OM API. This command applies to DB/DC systems and DCCTL systems. The **DELETE LTERM** command applies only to remote MSC LTERMs and is valid only when both MSC and the dynamic definition of MSC resources are enabled (MSC=Y is specified in the startup parameters and MSCRSCS=DYN is specified in the MSC section of the DFSDFxxx member).

The **DELETE LTERM** command is not valid on the XRF alternate or FDBR region.

This command is recoverable.

Before you attempt to delete an MSC remote LTERM, make sure that the remote LTERM is not in use. If the remote LTERM is in use, the delete fails. Issue the **QUERY LTERM NAME(ltermname) SHOW(STATUS)** command to check the status of the LTERM.

In a sysplex environment with multiple IMS systems, the delete might succeed on some IMS systems and fail on others.



Changes that are made to MSC resources by the DELETE command are logged to save them across warm and emergency restarts. The changes are not saved across a cold start of IMS unless the MSC resources are also deleted from the stage-1 system definition macro input.

If your MSC resources are defined by using stage-1 system definition macros, delete the resource definition by removing the macro that defines the resource from the stage-1 system definition input and regenerate the MSC resources into the DFSCLL3x member in the IMS.SDFSRESL data set.

## Output fields

The following table shows the **DELETE LTERM** output fields. The columns in the table are as follows:

### Short label

Contains the short label that is generated in the XML output.

### Long label

Contains the long label that is generated in the XML output.

### Keyword

Identifies keyword on the command that caused the field to be generated. N/A appears for output fields that are always returned. *error* appears for output fields that are returned only in case of an error.

### Meaning

Provides a brief description of the output field.

Table 210. Output fields for the DELETE LTERM command

| Short label | Long label | Keyword      | Meaning   |
|-------------|------------|--------------|---|
| CC          | CC         | N/A          | Completion code.  |
| CCTXT       | CCText     | <i>error</i> | Completion code text that briefly explains the nonzero completion code.   |
| ERRT        | ErrorText  | <i>error</i> | Error text that provides diagnostic information. Error text can be returned for a nonzero completion code and further explains the completion code. |
| MBR         | MbrName    | N/A          | IMSpIplex member that built the output line.  |
| LTERM       | Lterm      | N/A          | The name of the remote logical terminal. The remote logical terminal name is always returned.   |

## Return and reason codes

The following table includes the return and reason codes and a brief explanation of the codes. The return or reason code returned for the command might also indicate an error from a CSL request.

Table 211. Return and reason codes for the DELETE LTERM command

| Return code | Reason code | Meaning   |
|-------------|-------------|---|
| X'00000000' | X'00000000' | The command completed successfully. The command output contains a line for each resource, which is accompanied by its completion code. If NAME(*) is specified without OPTION(ALLRSP), no output lines are returned. See the completion code table for details. |

Table 211. Return and reason codes for the DELETE LTERM command (continued)

| Return code | Reason code | Meaning   |
|-------------|-------------|---|
| X'0000000C' | X'00003000' | Command was successful for some resources but failed for others. The command output contains a line for each resource, which is accompanied by its completion code. If NAME(*) is specified without OPTION(ALLRSP), only resources with nonzero completion codes are returned. See the completion code table for details. |
| X'0000000C' | X'00003004' | Command was not successful for any of the resources. The command output contains a line for each resource, which is accompanied by its completion code. See the completion code table for details.  |
| X'00000010' | X'0000400C' | Command is not valid on the XRF alternate.  |
| X'00000010' | X'0000402C' | Command is not valid because MSC is not enabled in the IMS system.  |
| X'00000010' | X'0000402D' | Command is not allowed because dynamic definition is not enabled for MSC. MSCRSCS=DYN is not specified in the MSC section of the DFSDFxxx member of the IMS PROCLIB data set.   |
| X'00000014' | X'00005004' | DFSOCMD response buffer could not be obtained.  |
| X'00000014' | X'00005008' | DFSPPOOL storage could not be obtained.   |
| X'00000014' | X'00005010' | Unable to obtain latch.   |

## Completion codes

Errors unique to the processing of this command are returned as completion codes. The following table includes an explanation of the completion codes.

Table 212. Completion codes for the DELETE LTERM command

| Completion code | Completion code text         | Meaning  |
|-----------------|------------------------------|--|
| 0               |                              | The command completed successfully for the resource.   |
| 10              | NO RESOURCES FOUND           | The resource name is invalid or the value that is specified on the NAME keyword does not match the name of any resource within this resource type.   |
| 17              | ANOTHER CMD IN PROGRESS      | Another command (such as DELETE or UPDATE) is in progress for this LTERM. This could also mean this command, if the resource is specified by more than one specific or wildcard parameter. |
| 48              | NOT ALLOWED FOR IMS RESOURCE | The resource name is invalid as a remote lterm. The resource is an IMS-defined resource.   |
| 90              | INTERNAL ERROR               | An IMS system service failure.   |

## Examples

The following are examples of the **DELETE LTERM** command:

### Example 1 for DELETE LTERM command

In the following example, the DELETE LTERM command is issued to delete MSC remote LTERMs LTERM20B, BADNAME, and LTERM23C. The delete is successful for remote LTERMs LTERM20B and LTERM23C, as shown by the completion code 0. The delete fails for BADNAME because no remote LTERM is named BADNAME.

TSO SPOC input:

```
DELETE LTERM NAME(LTERM20B,BADNAME,H0G5*,LTERM23C)
```

TSO SPOC output:

| Lterm    | MbrName | CC | CCText             |
|----------|---------|----|--------------------|
| BADNAME  | IMS1    | 10 | NO RESOURCES FOUND |
| H0G50    | IMS1    | 0  |                    |
| H0G51    | IMS1    | 0  |                    |
| H0G52    | IMS1    | 0  |                    |
| LTERM20B | IMS1    | 0  |                    |
| LTERM23C | IMS1    | 0  |                    |

OM API input:

```
CMD(DEL LTERM NAME(LTERM20B,BADNAME,H0G5*,LTERM23C))
```

OM API output:

```
<imsout>
<ctl>
<omname>OM10M </omname>
<omvsn>1.7.0</omvsn>
<xmlvsn>20 </xmlvsn>
<statime>2014.268 16:10:13.937131</statime>
<stotime>2014.268 16:10:13.938009</stotime>
<staseq>CDCF651DB8FEBD05</staseq>
<stoseq>CDCF651DB9359185</stoseq>
<rqsttkn1>USRT011 10091013</rqsttkn1>
<rc>0200000C</rc>
<rsn>00003008</rsn>
<rsnmsg>CSLN054I</rsnmsg>
<rsntxt>None of the clients were successful.</rsntxt>
</ctl>
<cmderr>
<mbr name="IMS1 ">
<typ>IMS </typ>
<styp>DBDC </styp>
<rc>0000000C</rc>
<rsn>00003000</rsn>
<rsntxt>At least one request successful</rsntxt>
</mbr>
</cmderr>
<cmd>
<master>IMS1 </master>
<userid>USRT011 </userid>
<verb>DEL </verb>
<kwd>LTERM </kwd>
<input>DELETE LTERM NAME(LTERM20B,BADNAME,H0G5*,LTERM23C) </input>
</cmd>
<cmdrsphdr>
<hdr sbl="LTERM" llbl="Lterm" scope="LCL" sort="a" key="1" scroll="n
o" len="8" dtype="CHAR" align="left" />
<hdr sbl="MBR" llbl="MbrName" scope="LCL" sort="a" key="2" scroll="no"
len="8" dtype="CHAR" align="left" />
<hdr sbl="CC" llbl="CC" scope="LCL" sort="a" key="3" scroll="yes"
len="4" dtype="INT" align="right" skipb="no" />
<hdr sbl="CCTXT" llbl="CCText" scope="LCL" sort="n" key="0"
scroll="yes" len="*" dtype="CHAR" skipb="yes" align="left" />
<hdr sbl="ERRT" llbl="ErrorText" scope="LCL" sort="n" key="0"
scroll="yes" len="*" dtype="CHAR" skipb="yes" align="left" />
</cmdrsphdr>
```

```

<cmdrspdata>
<rsp>LTERM(LTERM20B) MBR(IMS1 ) CC( 0) </rsp>
<rsp>LTERM(BADNAME ) MBR(IMS1 ) CC( 10) CCTXT(NO RESOURCES FOUND)
</rsp>
<rsp>LTERM(H0G52 ) MBR(IMS1 ) CC( 0) </rsp>
<rsp>LTERM(LTERM23C) MBR(IMS1 ) CC( 0) </rsp>
<rsp>LTERM(H0G51 ) MBR(IMS1 ) CC( 0) </rsp>
<rsp>LTERM(H0G50 ) MBR(IMS1 ) CC( 0) </rsp>
</cmdrspdata>
</imsout>

```

## DELETE MSLINK command

Use the **DELETE MSLINK** command to delete a Multiple Systems Coupling (MSC) logical link from an online IMS system.

Subsections:

- [“Environment” on page 400](#)
- [“Syntax” on page 400](#)
- [“Keywords” on page 400](#)
- [“Usage notes” on page 401](#)
- [“Output fields” on page 401](#)
- [“Return and reason codes” on page 402](#)
- [“Completion codes” on page 402](#)
- [“Examples” on page 403](#)

### Environment

The following table lists the environments (DB/DC, DBCTL, and DCCTL) in which you can use the command and keywords.

Table 213. Valid environments for the DELETE MSLINK command and keywords

| Command / Keywords                   | DB/DC | DBCTL | DCCTL |
|--------------------------------------|-------|-------|-------|
| <b>DELETE MSLINK</b> NAME() OPTION() | X     |       | X     |

### Syntax

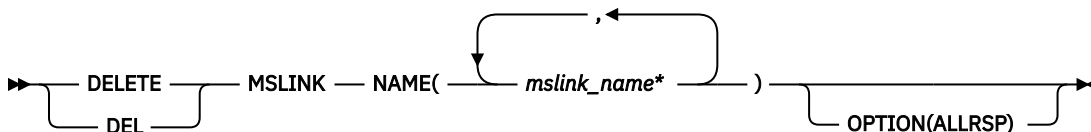

### Keywords

The following keywords are valid for the **DELETE MSLINK** command:

#### NAME

Specify one or more 1 - 8 character names of MSC logical links. Wildcards are supported in the name. Examples of valid names are NAME(\*) and NAME(abc\*). If the NAME parameter specified is a specific or wildcard name, command responses are returned for all the resource names that are processed. For NAME(\*), command responses are returned only for the resource names that resulted in an error. OPTION(ALLRSP) can be specified with NAME(\*) to obtain the command responses for all the resource names that are processed.

## OPTION

Specifies additional functions to be completed along with the command.

## ALLRSP

Indicates that the response lines are to be returned for all resources that are processed on the command. The default action is to return response lines only for the resources that resulted in an error. ALLRSP is valid only with NAME(\*). ALLRSP is ignored for other NAME values.

## Usage notes

Before attempting to delete a logical link, make sure that the logical link is not in use and that any MSC logical link paths that reference the logical link are deleted or reassigned to another logical link. If the logical link is in use or is referenced by a logical link path, the delete fails.

- To check the status of the link, issue the **QUERY MSLINK** NAME(*mmlinknm*) SHOW(STATUS) command.
- To see which logical link paths (MSNAMEs) are assigned to the link, issue the **QUERY MSLINK** NAME(*mmlinknm*) SHOW(MSNAME).

Changes that are made to MSC resources by the DELETE command are logged to save them across warm and emergency restarts. The changes are not saved across a cold start of IMS unless the MSC resources are also deleted from the stage-1 system definition macro input.

If your MSC resources are defined by using stage-1 system definition macros, delete the resource definition by removing the macro that defines the resource from the stage-1 system definition input and regenerate the MSC resources into the DFSCLL3x member in the IMS.SDFSRESL data set.

The **DELETE MSLINK** command is valid only when both MSC and the dynamic definition of MSC resources are enabled (MSC=Y is specified in the startup parameters and MSCRSCS=DYN is specified in the MSC section of the DFSDFxxx member). This command is recoverable.

This command can be issued only through the OM API. This command applies to DB/DC systems and DCCTL systems.

In a Sysplex environment with multiple IMS systems, the delete might succeed on some IMS systems and fail on others.

The **DELETE MSLINK** command is not valid on the XRF alternate or FDBR region.

## Output fields

The following table shows the **DELETE MSLINK** output fields. The columns in the table are as follows:

### Short label

Contains the short label generated in the XML output.

### Long label

Contains the long label generated in the XML output.

### Keyword

Identifies keyword on the command that caused the field to be generated. N/A appears for output fields that are always returned. *error* appears for output fields that are returned only in case of an error.

### Meaning

Provides a brief description of the output field.

Table 214. Output fields for the DELETE MSLINK command

| Short label | Long label | Keyword | Meaning          |
|-------------|------------|---------|------------------|
| CC          | CC         | N/A     | Completion code. |

Table 214. Output fields for the DELETE MSLINK command (continued)

| Short label | Long label | Keyword      | Meaning   |
|-------------|------------|--------------|---|
| CCTXT       | CCText     | <i>error</i> | Completion code text that briefly explains the nonzero completion code.   |
| ERRT        | ErrorText  | <i>error</i> | Error text that provides diagnostic information. Error text can be returned for a nonzero completion code and further explains the completion code. |
| MBR         | MbrName    | N/A          | IMSplex member that built the output line.  |
| MSL         | MSLink     | N/A          | MSC logical link name.  |

## Return and reason codes

The following table includes the return and reason codes and a brief explanation of the codes. The return or reason code returned for the command might also indicate an error from a CSL request.

Table 215. Return and reason codes for the DELETE MSLINK command

| Return code | Reason code | Meaning  |
|-------------|-------------|--|
| X'00000000' | X'00000000' | Command completed successfully. The command output contains a line for each resource, accompanied by its completion code. If NAME(*) is specified without OPTION(ALLRSP), no output lines are returned. See the completion code table for details.   |
| X'0000000C' | X'00003000' | Command was successful for some resources but failed for others. The command output contains a line for each resource, accompanied by its completion code. If NAME(*) is specified without OPTION(ALLRSP), only resources with nonzero completion codes are returned. See the completion code table for details. |
| X'0000000C' | X'00003004' | Command was not successful for any of the resources. The command output contains a line for each resource, accompanied by its completion code. See the completion code table for details.  |
| X'00000010' | X'0000400C' | Command is not valid on the XRF alternate.   |
| X'00000010' | X'0000402C' | Command is not valid because MSC is not enabled in the IMS system.   |
| X'00000010' | X'0000402D' | Command is not allowed because dynamic definition is not enabled for MSC. MSCRSCS=DYN is not specified in the MSC section of the DFSDFxxx member of the IMS PROCLIB data set.  |
| X'00000014' | X'00005004' | DFSOCMD response buffer could not be obtained.   |
| X'00000014' | X'00005008' | DFSPPOOL storage could not be obtained.  |
| X'00000014' | X'00005010' | Unable to obtain latch.  |

## Completion codes

Errors unique to the processing of this command are returned as completion codes. The following table includes an explanation of the completion codes.

*Table 216. Completion codes for the DELETE MSLINK command*

| Completion code | Completion code text | Meaning  |
|-----------------|----------------------|--|
| 0               |                      | The command completed successfully for the resource.   |
| 10              | NO RESOURCES FOUND   | The resource name is invalid or the value that is specified on the NAME keyword does not match the name of any resource within this resource type. |
| 90              | INTERNAL ERROR       | An IMS system failure occurred.  |
| 20A             | REFERENCED BY MSNAME | The logical link cannot be deleted because it is referenced by one or more logical link paths (MSNAMEs).   |

### Examples

The following are examples of the **DELETE MSLINK** command:

#### **Example 1 for DELETE MSLINK command**

In the following example, the DELETE MSLINK command is used to try to delete MSC logical links LNK12M01, BADNAME, and LNKM0001. The delete is successful for logical link LNKM0001, as shown by the completion code 0. The delete fails for BADNAME because there is no logical link that is named BADNAME. The delete fails for logical link LNK12M01, because it is referenced by MSNAMEs LINK13M2 and LINK12M1.

TSO SPOC input:

```
DELETE MSLINK NAME(LNK12M01,BADNAME,LNKM0001)
```

TSO SPOC output:

```
MSLink  MbrName  CC  CCText
LNKM0001 IMS1      0
BADNAME IMS1      10 NO RESOURCES FOUND
LNK12M01 IMS1     20A REFERENCED BY MSNAME LINK13M2
LNK12M01 IMS1     20A REFERENCED BY MSNAME LINK12M1
```

OM API input:

```
CMD(DEL MSLINK NAME(LNK12M01,BADNAME,LNKM0001))
```

OM API output:

```
<ctl>
<omname>OM10M </omname>
<omvsn>1.7.0</omvsn>
<xmlvsn>20 </xmlvsn>
<statime>2015.019 22:23:01.853686</statime>
<stotime>2015.019 22:23:01.890630</stotime>
<staseq>CE6190CAE61F656C</staseq>
<stoseq>CE6190CAEF246DE2</stoseq>
<rqsttkn1>USRT011 10142301</rqsttkn1>
<rc>0200000C</rc>
<rsn>00003008</rsn>
<rsnmsg>CSLN054I</rsnmsg>
<rsntxt>None of the clients were successful.</rsntxt>
</ctl>
<cmderr>
<mbr name="IMS1 ">
```

```

<typ>IMS      </typ>
<styp>DBDC   </styp>
<rc>0000000C</rc>
<rsn>00003000</rsn>
<rsntxt>At least one request successful</rsntxt>
</mbr>
</cmderr>
<cmd>
<master>IMS1      </master>
<userid>USRT011  </userid>
<verb>DEL </verb>
<kwd>MSLINK      </kwd>
<input>DELETE MSLINK NAME(LNK12M01,BADNAME,LNKM0001) </input>
</cmd>
<cmdsphdr>
<hdr slbl="MSL" llbl="MSLink" scope="LCL" sort="a" key="1" scroll="no "
  len="8" dtype="CHAR" align="left" />
<hdr slbl="MBR" llbl="MbrName" scope="LCL" sort="a" key="2" scroll="no"
  len="8" dtype="CHAR" align="left" />
<hdr slbl="CC" llbl="CC" scope="LCL" sort="n" key="0" scroll="yes"
  len="4" dtype="INT" align="right" skipb="no" />
<hdr slbl="CCTXT" llbl="CCText" scope="LCL" sort="n" key="0"
  scroll="yes" len="*" dtype="CHAR" skipb="yes" align="left" />
<hdr slbl="ERRT" llbl="ErrorText" scope="LCL" sort="n" key="0"
  scroll="yes" len="*" dtype="CHAR" skipb="yes" align="left" />
</cmdsphdr>
<cmdspdata>
<rsp>MSL(LNK12M01) MBR(IMS1      ) CC( 20A) CCTXT(REFERENCED BY MSNAME)
  ERRT(LINK13M2) </rsp>
<rsp>MSL(BADNAME ) MBR(IMS1      ) CC( 10) CCTXT(NO RESOURCES FOUND)
</rsp>
<rsp>MSL(LNKM0001) MBR(IMS1      ) CC( 0) </rsp>
<rsp>MSL(LNK12M01) MBR(IMS1      ) CC( 20A) CCTXT(REFERENCED BY MSNAME)
  ERRT(LINK12M1) </rsp>
</cmdspdata>
</imsout>

```

## DELETE MSNAME command

Use the **DELETE MSNAME** command to delete a Multiple Systems Coupling (MSC) logical link path from an online IMS system.

Subsections:

- [“Environment” on page 404](#)
- [“Syntax” on page 405](#)
- [“Keywords” on page 405](#)
- [“Usage notes” on page 405](#)
- [“Output fields” on page 406](#)
- [“Return and reason codes” on page 406](#)
- [“Completion codes” on page 407](#)
- [“Examples” on page 408](#)

### Environment

The following table lists the environments (DB/DC, DBCTL, and DCCTL) in which you can use the command and keywords.

| Command / Keywords                   | DB/DC | DBCTL | DCCTL |
|--------------------------------------|-------|-------|-------|
| <b>DELETE MSNAME</b> NAME() OPTION() | X     |       | X     |



## Syntax

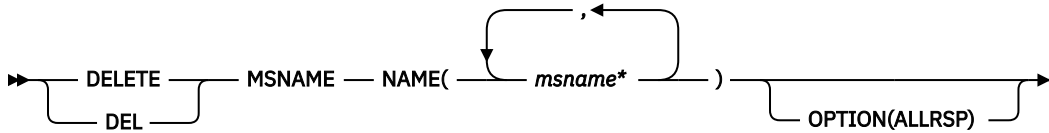

## Keywords

The following keywords are valid for the **DELETE MSNAME** command:

### NAME

Specify one or more 1 - 8 character names of MSC logical link paths. Wildcards are supported in the name. Examples of valid names are NAME(\*) and NAME(abc\*). If the NAME parameter specified is a specific or wildcard name, command responses are returned for all the resource names that are processed. For NAME(\*), command responses are returned only for the resource names that resulted in an error. OPTION(ALLRSP) can be specified with NAME(\*) to obtain the command responses for all the resource names that are processed.

### OPTION

Specifies options for the command.

#### ALLRSP

Indicates that the response lines are to be returned for all resources that are processed on the command. The default action is to return response lines only for the resources that result in an error. ALLRSP is valid only with NAME(\*). ALLRSP is ignored for other NAME values.

## Usage notes

Before you delete a logical link path, make sure that the logical link path is not in use and that any LTERMs or transactions that reference the MSNAME of the logical link path are deleted or reassigned to another MSNAME. If the logical link path is in use or is referenced by an LTERM or a transaction, the delete fails.

- Issue the **QUERY MSNAME** NAME(msname) SHOW(STATUS) command to check the status of the link.
- Issue the **QUERY TRAN** NAME(\*) SHOW(MSNAME) to see if any transactions reference the logical link path.
- Issue the **QUERY LTERM** NAME(\*) SHOW(MSNAME) to see if any LTERMs are assigned to the logical link path.

Changes that are made to MSC resources by the DELETE command are logged to save them across warm and emergency restarts. The changes are not saved across a cold start of IMS unless the MSC resources are also deleted from the stage-1 system definition macro input.

If your MSNAME resources are defined by using stage-1 systems definition macros, delete the MSNAME resource definition by removing the MSNAME macros that define the MSNAME resources from the stage-1 system definition input and regenerate the MSC MSNAME resources into the DFSCLC0x member in the IMS.SDFSRESL data set.

This command can be issued only through the OM API. This command applies to DB/DC systems and DCCTL systems.

In a Sysplex environment with multiple IMS systems, the delete might succeed on some IMS systems and fail on others.

The **DELETE MSNAME** command is valid only when both MSC and the dynamic definition of MSC resources are enabled (MSC=Y is specified in the startup parameters and MSCRSCS=DYN is specified in the MSC section of the DFSDFxxx member). This command is recoverable.

The **DELETE MSNAME** command is not valid on the XRF alternate or FDBR region.

In a shared queues environment, the **DELETE MSNAME** command deletes the MSC MSNAME (logical link path) locally in the IMS that has a physical link outside the IMSplex, and causes the dynamic MSNAME to be deleted in all the other IMSs in the shared queues group.

## Output fields

The following table shows the **DELETE MSNAME** output fields. The columns in the table are as follows:

### Short label

Contains the short label that is generated in the XML output.

### Long label

Contains the long label that is generated in the XML output.

### Keyword

Identifies keyword on the command that caused the field to be generated. N/A appears for output fields that are always returned. *error* appears for output fields that are returned only in case of an error.

### Meaning

Provides a brief description of the output field.

*Table 218. Output fields for the DELETE MSNAME command*

| Short label | Long label | Keyword      | Meaning   |
|-------------|------------|--------------|---|
| CC          | CC         | N/A          | Completion code.  |
| CCTXT       | CCText     | <i>error</i> | Completion code text that briefly explains the nonzero completion code.   |
| ERRT        | ErrorText  | <i>error</i> | Error text that provides diagnostic information. Error text can be returned for a nonzero completion code and further explains the completion code. |
| MBR         | MbrName    | N/A          | IMSplex member that built the output line.  |
| MSN         | MSName     | N/A          | The name of the logical link path.  |

## Return and reason codes

The following table includes the return and reason codes and a brief explanation of the codes. The return or reason code returned for the command might also indicate an error from a CSL request.

*Table 219. Return and reason codes for the DELETE MSNAME command*

| Return code | Reason code | Meaning   |
|-------------|-------------|---|
| X'00000000' | X'00000000' | The command completed successfully. The command output contains a line for each resource, which is accompanied by its completion code. If NAME(*) is specified without OPTION(ALLRSP), no output lines are returned. See the completion code table for details.   |
| X'0000000C' | X'00003000' | Command was successful for some resources but failed for others. The command output contains a line for each resource, which is accompanied by its completion code. If NAME(*) is specified without OPTION(ALLRSP), only resources with nonzero completion codes are returned. See the completion code table for details. |

Table 219. Return and reason codes for the DELETE MSNAME command (continued)

| Return code | Reason code | Meaning  |
|-------------|-------------|--|
| X'0000000C' | X'00003004' | Command was not successful for any of the resources. The command output contains a line for each resource, which is accompanied by its completion code. See the completion code table for details. |
| X'00000010' | X'0000400C' | Command is not valid on the XRF alternate.   |
| X'00000010' | X'0000402C' | Command is not valid because MSC is not enabled in the IMS system.   |
| X'00000010' | X'0000402D' | Command is not allowed because dynamic definition is not enabled for MSC. MSCRSCS=DYN is not specified in the MSC section of the DFSDFxxx member of the IMS PROCLIB data set.                      |
| X'00000014' | X'00005004' | DFSOCMD response buffer could not be obtained.   |
| X'00000014' | X'00005008' | DFSPPOOL storage could not be obtained.  |
| X'00000014' | X'00005010' | Unable to obtain latch.  |
| X'00000014' | X'00005058' | Synchronizing with DFSMNZ00 error.   |

## Completion codes

Errors unique to the processing of this command are returned as completion codes. The following table includes an explanation of the completion codes.

Table 220. Completion codes for the DELETE MSNAME command

| Completion code | Completion code text         | Meaning   |
|-----------------|------------------------------|---|
| 0               |                              | The command completed successfully for the resource.  |
| 10              | NO RESOURCES FOUND           | The resource name is invalid or the value that is specified on the NAME keyword does not match the name of any resource within this resource type.  |
| 17              | ANOTHER CMD IN PROGRESS      | Another command (such as DELETE or UPDATE) is in progress for this MSNAME. This could also mean this command, if the resource is specified by more than one specific or wildcard parameter. |
| 48              | NOT ALLOWED FOR IMS RESOURCE | An IMS system resource may not be deleted. For example, an IMS system MSNAME begins with the prefix DFSM or MSNS.   |
| 64              | GETSTOR STORAGE ERROR        | A DFSPPOOL GET(CMDP) storage request was unsuccessful.  |

Table 220. Completion codes for the DELETE MSNAME command (continued)

| Completion code | Completion code text               | Meaning   |
|-----------------|------------------------------------|---|
| 88              | REFERENCED BY TRAN                 | The MSNAME cannot be deleted because it is referenced by one or more remote transactions. The transaction name is returned as error text. You can take either of these actions: <ul style="list-style-type: none"> <li>• Issue a DELETE TRAN command to delete the transaction.</li> <li>• Issue an UPDATE TRAN command to assign the transaction to another MSNAME.</li> </ul> |
| 8D              | RESOURCE IS NOT STOPPED            | The resource is not stopped.  |
| 90              | INTERNAL ERROR                     | An IMS system service failure occurred.   |
| B7              | USE MANAGER ERROR                  | IMS encountered an internal error using the USE manager.  |
| 109             | COMMAND INVALID FOR DYNAMIC MSNAME | The DELETE command cannot complete because the specified MSNAME is a dynamic shared queues MSNAME.  |
| 10A             | SOURCE MSLINK NOT STOPPED          | The DELETE command cannot complete because the logical link that the specified MSNAME is assigned to is not stopped.  |
| 10E             | LAST MSNAME FOR LOW SIDL           | The logical link path cannot be deleted because it is the last MSNAME for the lowest local SID.   |
| 10F             | SIDL STILL LOCAL IN AN RSMB        | The logical link path cannot be deleted because there is a remote transaction with the SIDL value.  |
| 110             | SIDR STILL REMOTE IN AN RSMB       | The logical link path cannot be deleted because there is a remote transaction with the SIDR value.  |
| 145             | MSG IN PROGRESS ACROSS LINK        | The MSNAME cannot be deleted because there is a message in progress.  |
| 20B             | REFERENCED BY LTERM                | The MSNAME cannot be deleted because it is referenced by one or more remote LTERMs. The remote LTERM name is returned as error text. Suggested action: <ul style="list-style-type: none"> <li>• Issue a DELETE LTERM command to delete the remote LTERM.</li> </ul>   |

### Examples

The following are examples of the **DELETE MSNAME** command:

#### *Example 1 for DELETE MSNAME command*

In the following example, the DELETE MSNAME command is used to delete the MSC logical link paths LINK12T3, LINK13M3, MSNM001, BADNAME, and MSNV001. The delete fails for all logical link paths because they are either not stopped or have a bad name.

TSO SPOC input:

```
DELETE MSNAME NAME(LINK13M3,MSN%001,BADNAME,LINK12T3)
```

TSO SPOC output:

```
MSName  MbrName  CC CCText
BADNAME IMS1    10 NO RESOURCES FOUND
LINK12T3 IMS1    8D RESOURCE IS NOT STOPPED
LINK13M3 IMS1    8D RESOURCE IS NOT STOPPED
MSNM001  IMS1    8D RESOURCE IS NOT STOPPED
MSNV001  IMS1    8D RESOURCE IS NOT STOPPED
```

OM API input:

```
CMD(DEL MSNAME NAME(LINK13M3,MSN%001,BADNAME,LINK12T3))
```

OM API output:

```
TBD <imsout>
<ctl>
<omname>OM10M  </omname>
<omvsn>1.7.0</omvsn>
<xmlvsn>20  </xmlvsn>
<statime>2015.063 23:28:22.415541</statime>
<stotime>2015.063 23:28:22.416132</stotime>
<staseq>CE98F1761E8B5100</staseq>
<stoseq>CE98F1761EB04C00</stoseq>
<rqsttkn1>USRT011 10152822</rqsttkn1>
<rc>0200000C</rc>
<rsn>00003008</rsn>
<rsnmsg>CSLN054I</rsnmsg>
<rsntxt>None of the clients were successful.</rsntxt>
</ctl>
<cmderr>
<mbr name="IMS1  ">
<typ>IMS  </typ>
<styp>DBDC  </styp>
<rc>0000000C</rc>
<rsn>00003004</rsn>
<rsntxt>No requests were successful</rsntxt>
</mbr>
</cmderr>
<cmd>
<master>IMS1  </master>
<userid>USRT011 </userid>
<verb>DEL </verb>
<kwd>MSNAME  </kwd>
<input>DELETE MSNAME NAME(LINK13M3,MSN%001,BADNAME,LINK12T3) </input>
</cmd>
<cmdrsphdr>
<hdr slbl="MSN" llbl="MSName" scope="LCL" sort="a" key="1" scroll="no "
len="8" dtype="CHAR" align="left" />
<hdr slbl="MBR" llbl="MbrName" scope="LCL" sort="a" key="2" scroll="no"
len="8" dtype="CHAR" align="left" />
<hdr slbl="CC" llbl="CC" scope="LCL" sort="a" key="3" scroll="yes"
len="4" dtype="INT" align="right" skipb="no" />
<hdr slbl="CCTXT" llbl="CCText" scope="LCL" sort="n" key="0"
scroll="yes" len="*" dtype="CHAR" skipb="yes" align="left" />
<hdr slbl="ERRT" llbl="ErrorText" scope="LCL" sort="n" key="0"
scroll="yes" len="*" dtype="CHAR" skipb="yes" align="left" />
</cmdrsphdr>
<cmdrspdata>
<rsp>MSN(LINK13M3) MBR(IMS1 ) CC( 8D) CCTXT(RESOURCE IS NOT
STOPPED) </rsp>
<rsp>MSN(MSNM001 ) MBR(IMS1 ) CC( 8D) CCTXT(RESOURCE IS NOT
STOPPED) </rsp>
<rsp>MSN(BADNAME ) MBR(IMS1 ) CC( 10) CCTXT(NO RESOURCES FOUND)
</rsp>
<rsp>MSN(LINK12T3) MBR(IMS1 ) CC( 8D) CCTXT(RESOURCE IS NOT
STOPPED) </rsp>
<rsp>MSN(MSNV001 ) MBR(IMS1 ) CC( 8D) CCTXT(RESOURCE IS NOT
STOPPED) </rsp>
```

```
</cmdrspdata>
</imsout>
```

## DELETE MSPLINK command

Use the **DELETE MSPLINK** command to delete a Multiple Systems Coupling (MSC) physical link from an online IMS system.

Subsections:

- [“Environment” on page 410](#)
- [“Syntax” on page 410](#)
- [“Keywords” on page 410](#)
- [“Usage notes” on page 411](#)
- [“Output fields” on page 411](#)
- [“Return and reason codes” on page 412](#)
- [“Completion codes” on page 412](#)
- [“Examples” on page 413](#)

### Environment

The following table lists the environments (DB/DC, DBCTL, and DCCTL) in which you can use the command and keywords.

Table 221. Valid environments for the DELETE MSPLINK command and keywords

| Command / Keywords                    | DB/DC | DBCTL | DCCTL |
|---------------------------------------|-------|-------|-------|
| <b>DELETE MSPLINK</b> NAME() OPTION() | X     |       | X     |

### Syntax

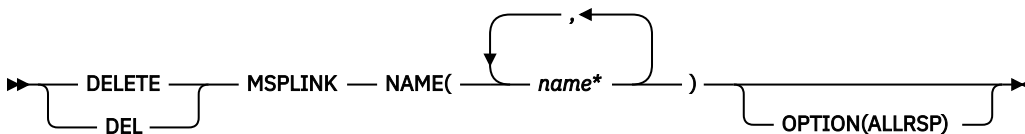

### Keywords

The following keywords are valid for the **DELETE MSPLINK** command:

#### NAME

Specify one or more 1 - 8 character names of MSC physical links. Wildcards are supported in the name. Examples of valid names are NAME(\*) and NAME(abc\*). If the NAME parameter specified is a specific or wildcard name, command responses are returned for all the resource names that are processed. For NAME(\*), command responses are returned only for the resource names that resulted in an error. OPTION(ALLRSP) can be specified with NAME(\*) to obtain the command responses for all the resource names that are processed.

#### OPTION

Specifies additional functions to be completed along with the command.

## ALLRSP

Indicates that the response lines are to be returned for all resources that are processed on the command. The default action is to return response lines only for the resources that result in an error. ALLRSP is valid only with NAME(\*). ALLRSP is ignored for other NAME values.

## Usage notes

Before you delete a physical link, make sure that the physical link is not in use and that any MSC logical link that are assigned to the physical link are deleted or reassigned to another physical link. If the physical link is in use or is referenced by a logical link, the delete fails.

- Issue the **QUERY MSPLINK** NAME(*msplinknm*) SHOW(STATUS) command to check the status of the link.
- Issue the **QUERY MSPLINK** NAME(*msplinknm*) SHOW(MSLINK) to see if any logical links are assigned to the link.

Changes that are made to MSC resources by the DELETE command are logged to save them across warm and emergency restarts. The changes are not saved across a cold start of IMS unless the MSC resources are also deleted from the stage-1 system definition macro input.

If your MSC resources are defined by using stage-1 system definition macros, delete the resource definition by removing the macro that defines the resource from the stage-1 system definition input and regenerate the MSC resources into the DFSCLL3x member in the IMS.SDFSRESL data set.

This command can be issued only through the OM API. This command applies to DB/DC systems and DCCTL systems.

The **DELETE MSPLINK** command is valid only when the dynamic definition of MSC resources is enabled (MSCRSCS=DYN is specified in the MSC section of the DFSDFxxx member). This command is recoverable.

The **DELETE MSPLINK** command is not valid on the XRF alternate or FDBR region.

In a Sysplex environment with multiple IMS systems, the delete might succeed on some IMS systems and fail on others.

## Output fields

The following table shows the **DELETE MSPLINK** output fields. The columns in the table are as follows:

### Short label

Contains the short label generated in the XML output.

### Long label

Contains the long label generated in the XML output.

### Keyword

Identifies keyword on the command that caused the field to be generated. N/A appears for output fields that are always returned. *error* appears for output fields that are returned only in case of an error.

### Meaning

Provides a brief description of the output field.

Table 222. Output fields for the DELETE MSPLINK command

| Short label | Long label | Keyword      | Meaning   |
|-------------|------------|--------------|---|
| CC          | CC         | N/A          | The completion code.  |
| CCTXT       | CCText     | <i>error</i> | The completion code text that briefly explains the nonzero completion code. |

Table 222. Output fields for the DELETE MSPLINK command (continued)

| Short label | Long label | Keyword      | Meaning   |
|-------------|------------|--------------|---|
| ERRT        | ErrorText  | <i>error</i> | Error text that provides diagnostic information. Error text can be returned for a nonzero completion code and further explains the completion code. |
| MBR         | MbrName    | N/A          | IMSplex member that built the output line.  |
| MSCP        | MSPLink    | N/A          | The name of the physical link.  |

## Return and reason codes

The following table includes the return and reason codes and a brief explanation of the codes. The return or reason code returned for the command might also indicate an error from a CSL request.

Table 223. Return and reason codes for the DELETE MSPLINK command

| Return code | Reason code | Meaning  |
|-------------|-------------|--|
| X'00000000' | X'00000000' | Command completed successfully. The command output contains a line for each resource, accompanied by its completion code. If NAME(*) is specified without OPTION(ALLRSP), no output lines are returned. See the completion code table for details.   |
| X'0000000C' | X'00003000' | Command was successful for some resources but failed for others. The command output contains a line for each resource, accompanied by its completion code. If NAME(*) is specified without OPTION(ALLRSP), only resources with nonzero completion codes are returned. See the completion code table for details. |
| X'0000000C' | X'00003004' | Command was not successful for any of the resources. The command output contains a line for each resource, accompanied by its completion code. See the completion code table for details.  |
| X'00000010' | X'0000400C' | Command is not valid on the XRF alternate.   |
| X'00000010' | X'0000402C' | Command is not valid because MSC is not enabled in the IMS system.   |
| X'00000010' | X'0000402D' | Command is not allowed because dynamic definition is not enabled for MSC. MSCRSCS=DYN is not specified in the MSC section of the DFSDFxxx member of the IMS PROCLIB data set.  |
| X'00000014' | X'00005004' | DFSOCMD response buffer could not be obtained.   |
| X'00000014' | X'00005008' | DFSPPOOL storage could not be obtained.  |
| X'00000014' | X'00005010' | Unable to obtain latch.  |

## Completion codes

Errors unique to the processing of this command are returned as completion codes. The following table includes an explanation of the completion codes.



Table 224. Completion codes for the DELETE MSPLINK command

| Completion code | Completion code text    | Meaning  |
|-----------------|-------------------------|--|
| 0               |                         | The command completed successfully for the resource.   |
| 10              | NO RESOURCES FOUND      | The resource name is invalid or the value that is specified on the NAME keyword does not match the name of any resource within this resource type.   |
| 17              | ANOTHER CMD IN PROGRESS | Another command (such as DELETE or UPDATE) is in progress for this program. This could also mean this command, if the resource is specified by more than one specific or wildcard parameter.     |
| 8D              | RESOURCE IS NOT STOPPED | The physical link cannot be deleted because the physical link is not stopped. To stop the link, issue the <b>/PSTOP MSPLINK</b> command or the type-2 <b>UPDATE MSPLINK STOP(LOGON)</b> command. |
| 209             | REFERENCED BY MSLINK    | The physical link cannot be deleted because a logical link is assigned to the physical link.   |

## Examples

### Example 1 for DELETE MSPLINK command

In the following example, a DELETE MSPLINK command is used to delete the physical links PLNK12V, BADNAME, and PLNK12VU. The delete fails for all of the physical links for different reasons. One line is issued for each MSC logical link that references the physical link. The DELETE fails for physical link BADNAME because there is no physical link that is named BADNAME. The DELETE fails for physical links PLNK12V because it is referenced by an MSC logical link. The DELETE fails for physical link PLNK12VU because it is not stopped.

TSO SPOC input:

```
DELETE MSPLINK NAME (PLNK12V ,BADNAME ,PLNK12VU)
```

TSO SPOC output:

```
BADNAME IMS1      10 NO RESOURCES FOUND
PLNK12V IMS1      8D RESOURCE IS NOT STOPPED
PLNK12V IMS1      209 REFERENCED BY MSLINK      LNK12V01
PLNK12V IMS1      209 REFERENCED BY MSLINK      LNK12V02
PLNK12V IMS1      209 REFERENCED BY MSLINK      LNK12V03
PLNK12V IMS1      209 REFERENCED BY MSLINK      DFSL0028
PLNK12VU IMS1     8D RESOURCE IS NOT STOPPED
```

OM API input:

```
CMD(DEL MSPLINK NAME (PLNK12V ,BADNAME ,PLNK12VU))
```

OM API output:

```
<imsout>
<ctl>
<omname>OM10M  </omname>
<omvsn>1.7.0</omvsn>
<xmlvsn>20  </xmlvsn>
<statime>2014.274 16:32:13.201064</statime>
```

```

<stotime>2014.274 16:32:13.201473</stotime>
<staseq>CDD6F538A2EA8600</staseq>
<stoseq>CDD6F538A3041D80</stoseq>
<rqsttkn1>USRT011 10093213</rqsttkn1>
<rc>0200000C</rc>
<rsn>00003008</rsn>
<rsnmsg>CSLN054I</rsnmsg>
<rsntxt>None of the clients were successful.</rsntxt>
</ctl>
<cmderr>
<mbr name="IMS1 ">
<typ>IMS </typ>
<styp>DBDC </styp>
<rc>0000000C</rc>
<rsn>00003004</rsn>
<rsntxt>No requests were successful</rsntxt>
</mbr>
</cmderr>
<cmd>
<master>IMS1 </master>
<userid>USRT011 </userid>
<verb>DEL </verb>
<kwd>MSPLINK </kwd>
<input>DELETE MSPLINK NAME(PLNK12V,BADNAME,PLNK12VU) </input>
</cmd>
<cmdrsphdr>
<hdr slbl="MSP" llbl="MSPLink" scope="LCL" sort="a" key="1" scroll="n
o" len="8" dtype="CHAR" align="left" />
<hdr slbl="MBR" llbl="MbrName" scope="LCL" sort="a" key="2" scroll="no"
len="8" dtype="CHAR" align="left" />
<hdr slbl="CC" llbl="CC" scope="LCL" sort="n" key="0" scroll="yes"
len="4" dtype="INT" align="right" skipb="no" />
<hdr slbl="CCTXT" llbl="CCText" scope="LCL" sort="n" key="0"
scroll="yes" len="*" dtype="CHAR" skipb="yes" align="left" />
<hdr slbl="ERRT" llbl="ErrorText" scope="LCL" sort="n" key="0"
scroll="yes" len="*" dtype="CHAR" skipb="yes" align="left" />
</cmdrsphdr>
<cmdrspdata>
<rsp>MSP(PLNK12V ) MBR(IMS1 ) CC( 8D) CCTXT(RESOURCE IS NOT
STOPPED) </rsp>
<rsp>MSP(BADNAME ) MBR(IMS1 ) CC( 10) CCTXT(NO RESOURCES FOUND)
</rsp>
<rsp>MSP(PLNK12VU) MBR(IMS1 ) CC( 8D) CCTXT(RESOURCE IS NOT
STOPPED) </rsp>
<rsp>MSP(PLNK12V ) MBR(IMS1 ) CC( 209) CCTXT(REFERENCED BY MSLINK)
ERRT(LNK12V01) </rsp>
<rsp>MSP(PLNK12V ) MBR(IMS1 ) CC( 209) CCTXT(REFERENCED BY MSLINK)
ERRT(LNK12V02) </rsp>
<rsp>MSP(PLNK12V ) MBR(IMS1 ) CC( 209) CCTXT(REFERENCED BY MSLINK)
ERRT(LNK12V03) </rsp>
<rsp>MSP(PLNK12V ) MBR(IMS1 ) CC( 209) CCTXT(REFERENCED BY MSLINK)
ERRT(DFSL0028) </rsp>
</cmdrspdata>
</imsout>

```

## DELETE OTMADESC command

Use the **DELETE OTMADESC** command to delete an existing OTMA destination descriptor without restarting IMS.

Subsections:

- [“Environment” on page 415](#)
- [“Syntax” on page 415](#)
- [“Keywords” on page 415](#)
- [“Usage notes” on page 415](#)
- [“Output fields” on page 415](#)
- [“Return, reason, and completion codes” on page 416](#)
- [“Examples” on page 417](#)

## Environment

The following table lists the environments (DB/DC, DBCTL, and DCCTL) in which you can use the commands and keywords.

Table 225. Valid environments for the **DELETE OTMADESC** command and keywords

| Command / Keywords     | DB/DC | DBCTL | DCCTL |
|------------------------|-------|-------|-------|
| <b>DELETE OTMADESC</b> | X     |       | X     |
| NAME                   | X     |       | X     |
| OPTION                 | X     |       | X     |

## Syntax

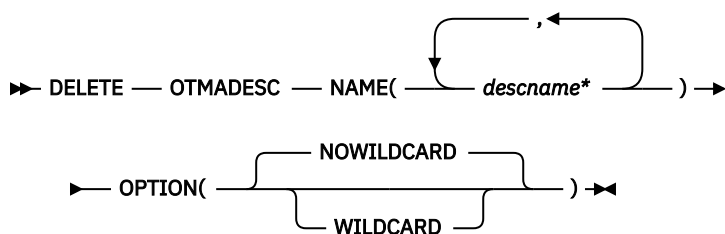

## Keywords

The following keywords are valid for the **DELETE OTMADESC** command:

### **NAME(descname\*)**

A required keyword parameter that specifies a 1- to 8-character destination routing descriptor name. The destination routing descriptor name can have an asterisk (\*) at the end to mask a group of names. The asterisk can be used by itself to mask all defined descriptor names in the system. Issuing the **DELETE** command with a name of asterisk only will delete all entries in the destination routing descriptors. If you intend to delete all entries in the table, you must specify **DELETE NAME(\*) OPTION(WILDCARD)**. All entries including the entry of asterisk are deleted.

### **OPTION(NOWILDCARD | WILDCARD)**

Specify **NOWILDCARD** to delete the descriptor having a name with an asterisk as an entry from the table of destination routing descriptors. Specify **WILDCARD** to delete the groups of names that the asterisk is masking. If the name with the asterisk is also an entry in the table, the name with the asterisk itself is deleted.

## Usage notes

The **DELETE OTMADESC** command requires only the **NAME** keyword. If the **NAME** keyword contains the masked character of asterisk, it will not delete the group of names it is masking. It will only delete the name with the asterisk as its own entry in the destination routing descriptors. If the **OPTION(WILDCARD)** keyword is specified, then the group of names under a masked destination routing descriptor name will also be deleted; the name with the asterisk is also deleted. Log records will be created to track the dynamic changes to destination routing descriptors on restart of IMS.

The **DELETE OTMADESC** command is not valid in an XRF alternate environment.

## Output fields

The following table shows the **DELETE OTMADESC** output fields. The columns in the table are:

**Short label**

Contains the short label generated in the XML output.

**Long label**

Contains the column heading for the output field in the formatted output.

**Keyword**

Identifies the keyword on the command that caused the field to be generated. N/A appears for output fields that are always returned. *error* appears for output fields that are returned only in case of an error.

**Meaning**

Provides a brief description of the output field.

*Table 226. Output fields for the DELETE OTMADESC command*

| Short label | Long label | Keyword | Meaning  |
|-------------|------------|---------|--|
| CC          | CC         | N/A     | Completion code for the line of output. The completion code indicates whether IMS was able to process the command for the specified resource. See <a href="#">“Return, reason, and completion codes”</a> on page 416 for more information. The completion code is always returned. |
| CCTXT       | CCText     | N/A     | Completion code text that briefly explains the meaning of the non-zero completion code. This field is returned only for an error completion code.  |
| DEST        | DestName   | NAME    | Destination name.  |
| MBR         | MbrName    | N/A     | Member name.   |

**Return, reason, and completion codes**

An IMS return and reason code is returned to OM by the **DELETE OTMADESC** command. The OM return and reason codes that may be returned as a result of the **DELETE OTMADESC** command are standard for all commands entered through the OM API.

The following table includes the return and reason codes and a brief explanation of the codes. The return or reason code returned for the command might also indicate an error from a CSL request.

*Table 227. Return and reason codes for the DELETE OTMADESC command*

| Return code | Reason code | Meaning  |
|-------------|-------------|--|
| X'00000000' | X'00000000' | Command completed successfully. The command output contains a line for each resource, accompanied by its completion code. See <a href="#">Table 228 on page 417</a> for details. |
| X'02000008' | X'00002000' | The command contains an invalid verb or no client is registered for the verb.  |
| X'02000008' | X'00002004' | The command contains an invalid primary keyword or no client is registered for the keyword.  |
| X'02000008' | X'00002028' | The command contains an invalid keyword.   |
| X'02000008' | X'0000202C' | The command contains an unknown positional parameter.  |
| X'02000008' | X'00002034' | The command contains an incomplete keyword parameter.  |
| X'02000008' | X'00002038' | The command is missing a required parameter.   |

Table 227. Return and reason codes for the DELETE OTMADESC command (continued)

| Return code | Reason code | Meaning  |
|-------------|-------------|--|
| X'02000008' | X'0000203C' | The command contains an invalid keyword parameter value. |

The following table includes an explanation of the completion codes. Errors unique to the processing of this command are returned as completion codes. A completion code is returned for each action against an individual resource.

Table 228. Completion codes for the DELETE OTMADESC command

| Completion code | Completion code text             | Meaning  |
|-----------------|----------------------------------|--|
| 0               | Command completed successfully   | The <b>DELETE OTMADESC</b> command completed successfully for the resource.  |
| 163             | Descriptor not available for del | During delete processing, the entry in the table of destination routing descriptors might have already been deleted by another user. |
| 166             | No entries found                 | Command failed for <b>DELETE OTMADESC</b> , because no entries were found in the table of destination routing descriptors.           |

### Examples

The following are examples of the **DELETE OTMADESC** command:

#### Example 1 for DELETE OTMADESC command

TSO SPOC input:

```
DELETE OTMADESC NAME(OTMACL*)
```

TSO SPOC output:

```
DestName  MbrName  CC
OTMACL*   IMSA      0
```

**Explanation:** The **DELETE** command will delete only OTMACL\* and not delete OTMACL99, because the default for the OPTION keyword is NOWILDCARD. It treats OTMACL\* as a standalone entry in the table of destination routing descriptors.

#### Example 2 for DELETE OTMADESC command

TSO SPOC input:

```
DELETE OTMADESC NAME(OTMACL*) OPTION(WILDCARD)
```

TSO SPOC output:

```
DestName  MbrName  CC
OTMACL99  IMSA      0
OTMACL*   IMSA      0
```

**Explanation:** The **DELETE** command will delete both OTMACL99 and OTMACL\*, because the OPTION keyword is coded with WILDCARD. It treats OTMACL\* as a mask for a group of names, so it includes OTMACL99 and OTMACL\* as an entry in itself in the table of destination routing descriptors.

## Related concepts

How to interpret CSL request return and reason codes (System Programming APIs)

## Related reference

“Command keywords and their synonyms” on page 59

All IMS command keywords and their synonyms, as well as keywords supported by the OM API, are listed. The list covers command keywords for the OM command processing clients such as IMS, ODBM, IMSCON, and RM.

## DELETE PGM command

Use the **DELETE PGM** command to delete program resources.

Subsections:

- “Environment” on page 418
- “Syntax” on page 418
- “Keywords” on page 418
- “Usage notes” on page 419
- “Output fields” on page 419
- “Return, reason, and completion codes” on page 420
- “Examples” on page 421

## Environment

The following table lists the environments (DB/DC, DBCTL, and DCCTL) in which you can use the command and keywords.

Table 229. Valid environments for the DELETE PGM command and keywords

| Command / Keywords | DB/DC | DBCTL | DCCTL |
|--------------------|-------|-------|-------|
| <b>DELETE PGM</b>  | X     | X     | X     |
| NAME               | X     | X     | X     |
| OPTION             | X     | X     | X     |

## Syntax

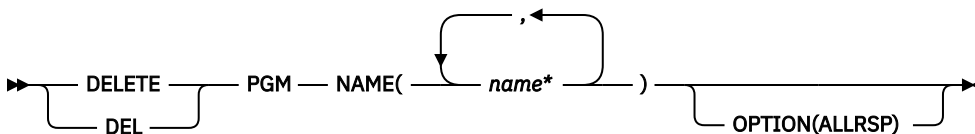

## Keywords

The following keywords are valid for the **DELETE PGM** command:

### NAME

Specifies the 1-8 character name of the program. Wildcards are supported in the name. Examples of valid names are NAME(\*) and NAME(abc\*). If the NAME parameter specified is a specific or wildcard name, command responses are returned for all the resource names that are processed. For NAME(\*), command responses are returned only for the resource names that resulted in an

error. OPTION(ALLRSP) can be specified with NAME(\*) to obtain the command responses for all the resource names that are processed.

### **OPTION**

Specifies additional functions to be performed along with the command.

### **ALLRSP**

Indicates that the response lines are to be returned for all resources that are processed on the command. The default action is to return response lines only for the resources that resulted in an error. It is valid only with NAME(\*). ALLRSP is ignored for other NAME values.

## **Usage notes**

This command can only be issued through the Operations Manager API. This command applies to DB/DC systems, DBCTL systems, and DCCTL systems.

The **DELETE PGM** command is not valid on the XRF alternate or FDBR region. The **DELETE PGM** command is not valid if online change for MODBLKS is enabled (DFSDFxxx or DFSCGxxx defined with MODBLKS=OLC or MODBLKS not defined).

This command is recoverable.

Each program is deleted individually, unlike the online change process where either all programs are deleted or no programs are deleted. The runtime resource definition for a program can be deleted only if the program is not in use. If the program is in use, the delete fails. In a sysplex environment with multiple IMS systems, the delete might succeed on some IMS systems and fail on others.

The **DELETE PGM** command removes ACB members from the 31-bit nonresident pool as well as the 64-bit storage pool.

The resources remain deleted across an IMS warm start or emergency restart. To ensure that the resources remain deleted across a cold start, the existing resource definitions must be exported to a system RDDS and then imported from the RDDS at cold start. Or, if the IMSRSC repository is enabled, the **DELETE DEFN** command must be issued to delete the definition from the repository. If the resource definitions are to be imported from the MODBLKS data set at cold start instead of from an RDDS, the resource definitions must be deleted from system definition and a new MODBLKS data set must be generated.

The **DELETE** command is not allowed for IMS resources that are identified with a definition type of IMS. For **DELETE PGM** commands, this means Fast Path utility program DBF#FPU0.

If the **DELETE** command is executed in an IMSplex using Resource Manager (RM) Structures, the program resources are not automatically removed from the structure. To remove the program resources, you can use the IMS Tools Resource Manager Structure utility that is included in IMS Tools Base v1.6 with APAR PH03561 or later. For more information, read the [IMS Tools Resource Manager Structure Utility](#) from the *IMS Tools Base* documentation. You can also use another vendor tool or write an RM client to delete resources from the resource structure.

## **Output fields**

The following table shows the **DELETE PGM** output fields. The columns in the table are as follows:

### **Short label**

Contains the short label generated in the XML output.

### **Long label**

Contains the long label generated in the XML output.

### **Keyword**

Identifies keyword on the command that caused the field to be generated. N/A appears for output fields that are always returned. *error* appears for output fields that are returned only in case of an error.

## Meaning

Provides a brief description of the output field.

Table 230. Output fields for the DELETE PGM command

| Short label | Long label | Keyword      | Meaning  |
|-------------|------------|--------------|--|
| CC          | CC         | N/A          | Completion code.   |
| CCTXT       | CCText     | <i>error</i> | Completion code text that briefly explains the meaning of the non-zero completion code.  |
| ERRT        | ErrorText  | <i>error</i> | Error text that provides diagnostic information. Error text can be returned for a non-zero completion code and further explains the completion code. |
| MBR         | MbrName    | N/A          | IMSplex member that built the output line.   |
| PGM         | PgmName    | PGM          | Program name.  |

## Return, reason, and completion codes

The following table includes the return and reason codes and a brief explanation of the codes. The return or reason code returned for the command might also indicate an error from a CSL request.

Table 231. Return and reason codes for the DELETE PGM command

| Return code | Reason code | Meaning   |
|-------------|-------------|---|
| X'00000000' | X'00000000' | Command completed successfully. The command output contains a line for each resource, accompanied by its completion code. If NAME(*) is specified without OPTION(ALLRSP), no output lines are returned. See the completion code table for details.  |
| X'0000000C' | X'00003000' | Command was successful for some resources but failed for others. The command output contains a line for each resource, accompanied by its completion code. If NAME(*) is specified without OPTION(ALLRSP), only resources with non-zero completion codes are returned. See the completion code table for details. |
| X'0000000C' | X'00003004' | Command was not successful for any of the resources. The command output contains a line for each resource, accompanied by its completion code. See the completion code table for details.   |
| X'00000010' | X'0000400C' | Command is not valid on the XRF alternate.  |
| X'00000010' | X'00004120' | Online change phase is in progress.   |
| X'00000010' | X'00004300' | Command is not allowed because online change for MODBLKS is enabled (DFSDFxxx or DFSCGxxx defined with MODBLKS=OLC, or MODBLKS not defined).  |
| X'00000014' | X'00005004' | DFSOCMD response buffer could not be obtained.  |
| X'00000014' | X'00005008' | DFSPPOOL storage could not be obtained.   |
| X'00000014' | X'0000500C' | AWE could not be obtained.  |



Errors unique to the processing of this command are returned as completion codes. The following table includes an explanation of the completion codes.

Table 232. Completion codes for the **DELETE PGM** command

| Completion code | Completion code text         | Meaning   | Error text           |
|-----------------|------------------------------|---|----------------------|
| 0               |                              | Command completed successfully for program.   |                      |
| 10              | NO RESOURCES FOUND           | Program name is invalid, or the wildcard parameter specified does not match any resource names.   |                      |
| 17              | ANOTHER CMD IN PROGRESS      | Another command (such as <b>DELETE</b> or <b>UPDATE</b> ) is in progress for this program. This could also mean this command, if the resource is specified by more than one specific or wildcard parameter.   |                      |
| 48              | NOT ALLOWED FOR IMS RESOURCE | <b>DELETE</b> command not allowed for IMS descriptor or resource. An example of an IMS resource include DBF#FPU0.   |                      |
| 73              | PROGRAM SCHEDULED            | Program is scheduled.   |                      |
| 7B              | REFERENCED BY RTCODE         | Routing code references the program to be deleted. The routing code name is returned as error text.<br><br><b>Suggested actions:</b><br><ul style="list-style-type: none"> <li>Issue <b>DELETE RTC</b> command to delete the routing code.</li> </ul> <i>or</i><br><ul style="list-style-type: none"> <li>Issue <b>UPDATE RTC</b> command to update the program to another name.</li> </ul> | rtcodename (8 chars) |
| 88              | REFERENCED BY TRAN           | Transaction references the program to be deleted. The transaction name is returned as error text.<br><br><b>Suggested actions:</b><br><ul style="list-style-type: none"> <li>Issue <b>DELETE TRAN</b> command to delete the transaction.</li> </ul> <i>or</i><br><ul style="list-style-type: none"> <li>Issue <b>UPDATE TRAN</b> command to update the program to another name.</li> </ul>  | tranname (8 char)    |
| 1D7             | IMPORT CHANGE LIST ERROR     | Resource is in the process of being imported from the change list in the IMSRSC repository, or the import from the change list failed. The resource cannot be deleted until it is successfully imported.  |                      |

### Examples

The following are examples of the **DELETE PGM** command:

### Example 1 for DELETE PGM command

TSO SPOC input:

```
DELETE PGM NAME(DFSSAM02,AUTPSB2,BADNAME,DFSSAM04)
```

TSO SPOC output:

```
Response for: DELETE PGM NAME(DFSSAM02,AUTPSB2,BADNAME,DFSSAM04)
PgmName  MbrName  CC CCText      ErrorText
AUTPSB2  IMS1      0
BADNAME  IMS1     10 NO RESOURCES FOUND
DFSSAM02 IMS1     88 REFERENCED BY TRAN PART
DFSSAM04 IMS1     88 REFERENCED BY TRAN ADDINV
DFSSAM04 IMS1     88 REFERENCED BY TRAN ADDPART
DFSSAM04 IMS1     88 REFERENCED BY TRAN DLETINV
DFSSAM04 IMS1     88 REFERENCED BY TRAN DLETPART
```

OM API input:

```
CMD(DEL PGM NAME(DFSSAM02,AUTPSB2,BADNAME,DFSSAM04))
```

OM API output:

```
<imsout>
<ctl>
<omname>OM10M </omname>
<omvsn>1.3.0</omvsn>
<xmlvsn>20 </xmlvsn>
<statime>2006.310 23:38:41.930125</statime>
<stotime>2006.310 23:38:41.931770</stotime>
<staseq>BFAACDEBAF38D540</staseq>
<stoseq>BFAACDEBAF9FA480</stoseq>
<rqsttkn1>USRT011 10153841</rqsttkn1>
<rc>0200000C</rc>
<rsn>00003008</rsn>
<rsnmsg>CSLN054I</rsnmsg>
<rsntxt>None of the clients were successful.</rsntxt>
</ctl>
<cmderr>
<mbr name="IMS1 ">
<typ>IMS </typ>
<styp>DBDC </styp>
<rc>0000000C</rc>
<rsn>00003000</rsn>
<rsntxt>At least one request successful</rsntxt>
</mbr>
</cmderr>
<cmd>
<master>IMS1 </master>
<userid>USRT011 </userid>
<verb>DEL </verb>
<kwd>PGM </kwd>
<input>DELETE PGM NAME(DFSSAM02,AUTPSB2,BADNAME,DFSSAM04) </input>
</cmd>
<cmdrsphdr>
<hdr slbl="PGM" llbl="PgmName" scope="LCL" sort="a" key="1" scroll="no"
  len="8" dtype="CHAR" align="left" />
<hdr slbl="MBR" llbl="MbrName" scope="LCL" sort="a" key="2" scroll="no"
  len="8" dtype="CHAR" align="left" />
<hdr slbl="CC" llbl="CC" scope="LCL" sort="n" key="0" scroll="yes"
  len="4" dtype="INT" align="right" skipb="no" />
<hdr slbl="CCTXT" llbl="CCText" scope="LCL" sort="n" key="0"
  scroll="yes" len="*" dtype="CHAR" skipb="yes" align="left" />
<hdr slbl="ERRT" llbl="ErrorText" scope="LCL" sort="n" key="0"
  scroll="yes" len="*" dtype="CHAR" skipb="yes" align="left" />
</cmdrsphdr>
<cmdrspdata>
<rsp>PGM(DFSSAM02) MBR(IMS1) CC( 88) CCTXT(REFERENCED BY TRAN)
  ERRT(PART ) </rsp>
<rsp>PGM(AUTPSB2 ) MBR(IMS1) CC( 0) </rsp>
<rsp>PGM(BADNAME ) MBR(IMS1) CC( 10) CCTXT(NO RESOURCES FOUND) </rsp>
<rsp>PGM(DFSSAM04) MBR(IMS1) CC( 88) CCTXT(REFERENCED BY TRAN)
  ERRT(ADDINV ) </rsp>
<rsp>PGM(DFSSAM04) MBR(IMS1) CC( 88) CCTXT(REFERENCED BY TRAN)
```

```

ERRR(ADDPART ) </isp>
<isp>PGM(DFSSAM04) MBR(IMS1) CC( 88) CCTXT(REFERENCED BY TRAN)
ERRR(DLETINV ) </isp>
<isp>PGM(DFSSAM04) MBR(IMS1) CC( 88) CCTXT(REFERENCED BY TRAN)
ERRR(DLETPART) </isp>
</cmdispdata>
</imsout>

```

**Explanation:** Delete programs DFSSAM02, AUTPSB2, BADNAME, and DFSSAM04. The delete is successful for program AUTPSB2, as shown by the completion code 0. The delete is rejected for DFSSAM02, because transaction PART refers to it. The delete fails for program DFSSAM04, because transactions ADDPART, ADDINV, DLETPART, and DLETINV refer to it. Transactions PART, ADDPART, ADDINV, DLETPART, and DLETINV must either be deleted or updated to refer to another program before deleting programs DFSSAM02 and DFSSAM04. The delete fails for BADNAME, because there is no program named BADNAME.

### Related concepts

[How to interpret CSL request return and reason codes \(System Programming APIs\)](#)

### Related tasks

[Deleting runtime application program resource and descriptor definitions with the DELETE command \(System Definition\)](#)

### Related reference

[“Command keywords and their synonyms” on page 59](#)

All IMS command keywords and their synonyms, as well as keywords supported by the OM API, are listed. The list covers command keywords for the OM command processing clients such as IMS, ODBM, IMSCON, and RM.

## DELETE PGMDESC command

Use the **DELETE PGMDESC** command to delete program descriptors.

Subsections:

- [“Environment” on page 423](#)
- [“Syntax” on page 423](#)
- [“Keywords” on page 424](#)
- [“Usage notes” on page 424](#)
- [“Output fields” on page 424](#)
- [“Return, reason, and completion codes” on page 425](#)
- [“Examples” on page 426](#)

### Environment

The following table lists the environments (DB/DC, DBCTL, and DCCTL) in which you can use the command and keywords.

*Table 233. Valid environments for the DELETE PGMDESC command and keywords*

| Command / Keywords    | DB/DC | DBCTL | DCCTL |
|-----------------------|-------|-------|-------|
| <b>DELETE PGMDESC</b> | X     | X     | X     |
| NAME                  | X     | X     | X     |
| OPTION                | X     | X     | X     |

### Syntax

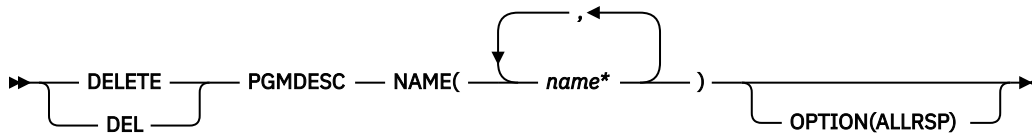

## Keywords

The following keywords are valid for the **DELETE PGMDESC** command:

### NAME

Specifies the 1-8 character name of the program descriptor. Wildcards are supported in the name. Examples of valid names are NAME(\*) and NAME(abc\*). If the NAME parameter specified is a specific or wildcard name, command responses are returned for all the descriptor names that are processed. For NAME(\*), command responses are returned only for the descriptor names that resulted in an error. OPTION(ALLRSP) can be specified with NAME(\*) to obtain the command responses for all the descriptor names that are processed.

### OPTION

Specifies additional functions to be performed along with the command.

#### ALLRSP

Indicates that the response lines are to be returned for all descriptors that are processed on the command. The default action is to return response lines only for the descriptors that resulted in an error. It is valid only with NAME(\*). ALLRSP is ignored for other NAME values.

## Usage notes

This command can only be issued through the Operations Manager API. This command applies to DB/DC systems, DBCTL systems, and DCCTL systems.

The **DELETE PGMDESC** command is not valid on the XRF alternate or FDBR region. The **DELETE PGMDESC** command is not valid if online change for MODBLKS is enabled (DFSDFxxx or DFSCGxxx defined with MODBLKS=OLC or MODBLKS not defined).

This command is recoverable.

Each descriptor is deleted individually. Individual deletion does not work like online change where either all descriptors are deleted or no descriptors are deleted. Descriptors can be successfully deleted if they are not currently in use. If a descriptor is in use, the delete fails. In a sysplex environment, the delete might succeed on some IMS systems and fail on others. A descriptor is in use if another command is in progress that references the descriptor.

The descriptors remain deleted across an IMS warm start or emergency restart. To ensure they remain deleted across a cold start, the existing descriptor definitions must be exported to an RDDS and imported from the RDDS at cold start.

The **DELETE PGMDESC** command is not allowed for IMS descriptors that are identified with a definition type of IMS. For **DELETE PGMDESC** commands, this means IMS-defined program descriptor DFSDSPG1.

## Output fields

The following table shows the **DELETE PGMDESC** output fields. The columns in the table are as follows:

### Short label

Contains the short label generated in the XML output.

### Long label

Contains the long label generated in the XML output.

**Keyword**

Identifies keyword on the command that caused the field to be generated. N/A appears for output fields that are always returned. *error* appears for output fields that are returned only in case of an error.

**Meaning**

Provides a brief description of the output field.

*Table 234. Output fields for the DELETE PGMDESC command*

| Short label | Long label | Keyword      | Meaning  |
|-------------|------------|--------------|--|
| CC          | CC         | N/A          | Completion code.   |
| CCTXT       | CCText     | <i>error</i> | Completion code text that briefly explains the meaning of the non-zero completion code.  |
| DESC        | DescName   | PGMDESC      | Program descriptor name.   |
| ERRT        | ErrorText  | <i>error</i> | Error text that provides diagnostic information. Error text can be returned for a non-zero completion code and further explains the completion code. |
| MBR         | MbrName    | N/A          | IMSplex member that built the output line.   |

**Return, reason, and completion codes**

The following table includes the return and reason codes and a brief explanation of the codes. The return or reason code returned for the command might also indicate an error from a CSL request.

*Table 235. Return and reason codes for the DELETE PGMDESC command*

| Return code | Reason code | Meaning  |
|-------------|-------------|--|
| X'00000000' | X'00000000' | Command completed successfully. The command output contains a line for each descriptor, accompanied by its completion code. If NAME(*) is specified without OPTION(ALLRSP), no output lines are returned. See the completion code table for details.   |
| X'0000000C' | X'00003000' | Command was successful for some descriptors but failed for others. The command output contains a line for each descriptor, accompanied by its completion code. If NAME(*) is specified without OPTION(ALLRSP), only descriptors with nonzero completion codes are returned. See the completion code table for details. |
| X'0000000C' | X'00003004' | Command was not successful for any of the descriptors. The command output contains a line for each descriptor, accompanied by its completion code. See the completion code table for details.  |
| X'00000010' | X'0000400C' | Command is not valid on the XRF alternate.   |
| X'00000010' | X'00004120' | Online change phase is in progress.  |
| X'00000010' | X'00004300' | Command is not allowed because online change for MODBLKS is enabled (DFSDFxxx or DFSCGxxx defined with MODBLKS=OLC, or MODBLKS not defined).   |
| X'00000014' | X'00005004' | DFSOCMD response buffer could not be obtained.   |

Table 235. Return and reason codes for the DELETE PGMDESC command (continued)

| Return code | Reason code | Meaning                                |
|-------------|-------------|--|
| X'00000014' | X'00005008' | DFSPool storage could not be obtained. |
| X'00000014' | X'0000500C' | AWE could not be obtained.             |

Errors unique to the processing of this command are returned as completion codes. The following table includes an explanation of the completion codes.

Table 236. Completion codes for the DELETE PGMDESC command

| Completion code | Completion code text            | Meaning  |
|-----------------|---------------------------------|--|
| 0               |                                 | Command completed successfully for program descriptor.   |
| 10              | NO RESOURCES FOUND              | Program name is invalid, or the wildcard parameter specified does not match any program descriptor names.  |
| 17              | ANOTHER CMD IN PROGRESS         | Another command (such as <b>DELETE</b> or <b>UPDATE</b> ) is in progress for this program descriptor. This could also mean this command, if the descriptor is specified by more than one specific or wildcard parameter. |
| 27              | REJECTED FOR DEFAULT DESCRIPTOR | <b>DELETE</b> command not allowed for user-defined default descriptor. You must issue an <b>UPDATE</b> command to set another descriptor as the default before deleting this descriptor.                                 |
| 48              | NOT ALLOWED FOR IMS RESOURCE    | <b>DELETE</b> command not allowed for IMS-defined descriptor. An example of an IMS-defined descriptor is DFSDSPG1.   |
| 1D7             | IMPORT CHANGE LIST ERROR        | Descriptor is in the process of being imported from the change list in the IMSRSC repository, or the import from the change list failed. The descriptor cannot be deleted until it is successfully imported.             |

## Examples

The following are examples of the **DELETE PGMDESC** command:

### Example 1 for DELETE PGMDESC command

TSO SPOC input:

```
DEL PGMDESC NAME(*) OPTION(ALLRSP)
```

TSO SPOC output:

```
Response for: DEL PGMDESC NAME(*) OPTION(ALLRSP)
DescName MbrName CC CText
DESC001 IMS1 0
DESC002 IMS1 0
DESC003 IMS1 0
```

```

DESC004 IMS1      0
DESC005 IMS1      0
DFS DSPG1 IMS1    48 NOT ALLOWED FOR IMS RESOURCE
DOPTDESC IMS1     0
FPEDESC  IMS1     0
GPSBDESC IMS1     0
PARLDESC IMS1     0
RESDESC  IMS1     0
TLSDESC  IMS1     27 REJECTED FOR DEFAULT DESCRIPTOR

```

OM API input:

```
CMD(DEL PGMDESC NAME(*) OPTION(ALLRSP))
```

OM API output:

```

<imsout>
<ctl>
<omname>OM10M  </omname>
<omvsn>1.3.0</omvsn>
<xmlvsn>20 </xmlvsn>
<stime>2006.310 23:09:24.532552</stime>
<stotime>2006.310 23:09:24.533243</stotime>
<staseq>BFAAC75FB314869E</staseq>
<stoseq>BFAAC75FB33FB7DE</stoseq>
<rqsttkn1>USRT011 10150924</rqsttkn1>
<rc>02000000C</rc>
<rsn>00003008</rsn>
<rsnmsg>CSLN054I</rsnmsg>
<rsntxt>None of the clients were successful.</rsntxt>
</ctl>
<cmderr>
<mbr name="IMS1  ">
<typ>IMS  </typ>
<styp>DBDC </styp>
<rc>00000000C</rc>
<rsn>00003000</rsn>
<rsntxt>At least one request successful</rsntxt>
</mbr>
</cmderr>
<cmd>
<master>IMS1  </master>
<userid>USRT011 </userid>
<verb>DEL </verb>
<kwd>PGMDESC  </kwd>
<input>DEL PGMDESC NAME(*) OPTION(ALLRSP) </input>
</cmd>
<cmdrsphdr>
<hdr slbl="DESC" llbl="DescName" scope="LCL" sort="a" key="1"
  scroll="no" len="8" dtype="CHAR" align="left" />
<hdr slbl="MBR" llbl="MbrName" scope="LCL" sort="a" key="2" scroll="no"
  len="8" dtype="CHAR" align="left" />
<hdr slbl="CC" llbl="CC" scope="LCL" sort="n" key="0" scroll="yes"
  len="4" dtype="INT" align="right" skipb="no" />
<hdr slbl="CCTXT" llbl="CCText" scope="LCL" sort="n" key="0"
  scroll="yes" len="*" dtype="CHAR" skipb="yes" align="left" />
<hdr slbl="ERRT" llbl="ErrorText" scope="LCL" sort="n" key="0"
  scroll="yes" len="*" dtype="CHAR" skipb="yes" align="left" />
</cmdrsphdr>
<cmdrspdata>
<rsp>DESC(DESC004 ) MBR(IMS1) CC( 0) </rsp>
<rsp>DESC(DESC005 ) MBR(IMS1) CC( 0) </rsp>
<rsp>DESC(DESC001 ) MBR(IMS1) CC( 0) </rsp>
<rsp>DESC(DOPTDESC) MBR(IMS1) CC( 0) </rsp>
<rsp>DESC(RESDESC ) MBR(IMS1) CC( 0) </rsp>
<rsp>DESC(DFS DSPG1) MBR(IMS1) CC( 48) CCTXT(NOT ALLOWED FOR IMS
  RESOURCE) </rsp>
<rsp>DESC(TLSDESC ) MBR(IMS1) CC( 27) CCTXT(REJECTED FOR DEFAULT
  DESCRIPTOR) </rsp>
<rsp>DESC(DESC002 ) MBR(IMS1) CC( 0) </rsp>
<rsp>DESC(PARLDESC) MBR(IMS1) CC( 0) </rsp>
<rsp>DESC(DESC003 ) MBR(IMS1) CC( 0) </rsp>
<rsp>DESC(FPEDESC ) MBR(IMS1) CC( 0) </rsp>
<rsp>DESC(GPSBDESC) MBR(IMS1) CC( 0) </rsp>
</cmdrspdata>
</imsout>

```

**Explanation:** A **DELETE PGMDESC** command is issued to delete all program descriptors from an active IMS system. Many program descriptors are successfully deleted, as indicated by the completion code 0. Because the **DELETE** command attempted to delete all of the program descriptors, **OPTION(ALLRSP)** is specified to display the successfully deleted program descriptors. Program descriptor **TLSDDESC** fails, because it is the default program descriptor. Program descriptor **DFSDSPG1** fails, because it is the IMS-defined program descriptor.

**Related concepts**

How to interpret CSL request return and reason codes (System Programming APIs)

**Related reference**

“Command keywords and their synonyms” on page 59

All IMS command keywords and their synonyms, as well as keywords supported by the OM API, are listed. The list covers command keywords for the OM command processing clients such as IMS, ODBM, IMSCON, and RM.

## DELETE RTC command

Use the **DELETE RTC** command to delete Fast Path routing codes.

Subsections:

- [“Environment” on page 428](#)
- [“Syntax” on page 428](#)
- [“Keywords” on page 428](#)
- [“Usage notes” on page 429](#)
- [“Output fields” on page 429](#)
- [“Return, reason, and completion codes” on page 430](#)
- [“Examples” on page 431](#)

**Environment**

The following table lists the environments (DB/DC, DBCTL, and DCCTL) in which you can use the command and keywords.

*Table 237. Valid environments for the DELETE RTC command and keywords*

| Command / Keywords | DB/DC | DBCTL | DCCTL |
|--------------------|-------|-------|-------|
| <b>DELETE RTC</b>  | X     |       | X     |
| NAME               | X     |       | X     |
| OPTION             | X     |       | X     |

**Syntax**

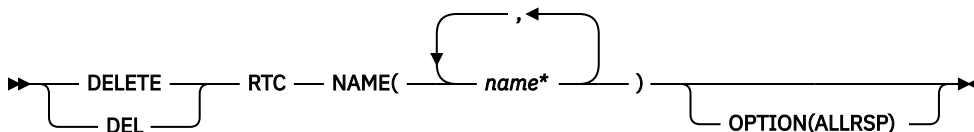

**Keywords**

The following keywords are valid for the **DELETE RTC** command:



**NAME**

Specifies the 1-8 character name of the routing code. Wildcards are supported in the name. Examples of valid names are NAME(\*) and NAME(abc\*). If the NAME parameter specified is a specific or wildcard name, command responses are returned for all the resource names that are processed. For NAME(\*), command responses are returned only for the resource names that resulted in an error. OPTION(ALLRSP) can be specified with NAME(\*) to obtain the command responses for all the resource names that are processed.

**OPTION**

Specifies additional functions to be performed along with the command.

**ALLRSP**

Indicates that the response lines are to be returned for all resources that are processed on the command. The default action is to return response lines only for the resources that resulted in an error. It is valid only with NAME(\*). ALLRSP is ignored for other NAME values.

**Usage notes**

This command can only be issued through the Operations Manager API. This command applies to DB/DC systems and DCCTL systems. The **DELETE RTC** command applies if Fast Path is installed.

The **DELETE RTC** command is not valid on the XRF alternate or FDBR region. The **DELETE RTC** command is not valid if online change for MODBLKS is enabled (DFSDFxxx or DFSCGxxx defined with MODBLKS=OLC or MODBLKS not defined).

This command is recoverable.

Each routing code is deleted individually, unlike the online change process where either all routing codes are deleted or no routing codes are deleted. The runtime resource definition for a routing code can only be deleted if the routing code is not in use. If the routing code is in use, the delete fails. In a sysplex environment with multiple IMSs, the delete might succeed on some IMSs and fail on others.

The resources remain deleted across an IMS warm start or emergency restart. To ensure that the resources remain deleted across a cold start, the existing resource definitions must be exported to a system RDDS and then imported from the RDDS at cold start. Or, if the IMSRSC repository is enabled, the **DELETE DEFN** command must be issued to delete the definition from the repository. If the resource definitions are to be imported from the MODBLKS data set at cold start instead of from an RDDS, the resource definitions must be deleted from system definition and a new MODBLKS data set must be generated.

**Output fields**

The following table shows the **DELETE RTC** output fields. The columns in the table are as follows:

**Short label**

Contains the short label generated in the XML output.

**Long label**

Contains the long label generated in the XML output.

**Keyword**

Identifies keyword on the command that caused the field to be generated. N/A appears for output fields that are always returned. *error* appears for output fields that are returned only in case of an error.

**Meaning**

Provides a brief description of the output field.

Table 238. Output fields for the DELETE RTC command

| Short label | Long label | Keyword      | Meaning  |
|-------------|------------|--------------|--|
| CC          | CC         | N/A          | Completion code.   |
| CCTXT       | CCText     | <i>error</i> | Completion code text that briefly explains the meaning of the non-zero completion code.  |
| ERRT        | ErrorText  | <i>error</i> | Error text that provides diagnostic information. Error text can be returned for a non-zero completion code and further explains the completion code. |
| MBR         | MbrName    | N/A          | IMSpIex member that built the output line.   |
| RTC         | RtcName    | RTC          | Routing code name.   |

### Return, reason, and completion codes

The following table includes the return and reason codes and a brief explanation of the codes. The return or reason code returned for the command might also indicate an error from a CSL request.

Table 239. Return and reason codes for the DELETE RTC command

| Return code | Reason code | Meaning   |
|-------------|-------------|---|
| X'00000000' | X'00000000' | Command completed successfully. The command output contains a line for each resource, accompanied by its completion code. If NAME(*) is specified without OPTION(ALLRSP), no output lines are returned. See the completion code table for details.  |
| X'0000000C' | X'00003000' | Command was successful for some resources but failed for others. The command output contains a line for each resource, accompanied by its completion code. If NAME(*) is specified without OPTION(ALLRSP), only resources with non-zero completion codes are returned. See the completion code table for details. |
| X'0000000C' | X'00003004' | Command was not successful for any of the resources. The command output contains a line for each resource, accompanied by its completion code. See the completion code table for details.   |
| X'00000010' | X'0000400C' | Command is not valid on the XRF alternate.  |
| X'00000010' | X'00004024' | No Fast Path defined.   |
| X'00000010' | X'00004120' | Online change phase is in progress.   |
| X'00000010' | X'00004300' | Command is not allowed because online change for MODBLKS is enabled (DFSDFxxx or DFSCGxxx defined with MODBLKS=OLC, or MODBLKS not defined).  |
| X'00000014' | X'00005004' | DFSOCMD response buffer could not be obtained.  |
| X'00000014' | X'00005008' | DFSPool storage could not be obtained.  |
| X'00000014' | X'0000500C' | AWE could not be obtained.  |

Errors unique to the processing of this command are returned as completion codes. The following table includes an explanation of the completion codes.

Table 240. Completion codes for the DELETE RTC command

| Completion code | Completion code text     | Meaning   |
|-----------------|--------------------------|---|
| 0               |                          | Command completed successfully for routing code.  |
| 10              | NO RESOURCES FOUND       | Routing code name is invalid, or the wildcard parameter specified does not match any routing code names.  |
| 17              | ANOTHER CMD IN PROGRESS  | Another command (such as <b>DELETE</b> or <b>UPDATE</b> ) is in progress for this routing code. This could also mean this command, if the resource is specified by more than one specific or wildcard parameter.                          |
| 39              | FP=E TRAN FOR RTC EXISTS | Routing code was created by IMS for a Fast Path exclusive transaction and cannot be deleted by a <b>DELETE RTC</b> command. The routing code can only be deleted by a <b>DELETE TRAN</b> command for the Fast Path exclusive transaction. |
| 73              | PROGRAM SCHEDULED        | Program is scheduled.   |
| 1D7             | IMPORT CHANGE LIST ERROR | Resource is in the process of being imported from the change list in the IMSRSC repository, or the import from the change list failed. The resource cannot be deleted until it is successfully imported.                                  |

## Examples

The following are examples of the **DELETE RTC** command:

### Example 1 for DELETE RTC command

TSO SPOC input:

```
DEL RTC NAME(OLCFR102,GFP1,BADNAME,EMHTX32,EMHTX32)
```

TSO SPOC output:

```
Response for: DEL RTC NAME(OLCFR102,GFP1,BADNAME,EMHTX32,EMHTXT32)
RtcName MbrName CC CText
BADNAME IMS1 10 NO RESOURCES FOUND
EMHTX32 IMS1 0
EMHTX32 IMS1 17 ANOTHER CMD IN PROGRESS
GFP1 IMS1 39 FP=E TRAN FOR RTC EXISTS
OLCFR102 IMS1 0
```

OM API input:

```
CMD(DEL RTC NAME(OLCFR102,GFP1,BADNAME,EMHTX32,EMHTX32))
```

OM API output:

```
<imsout>
<ctl>
<omname>OM10M </omname>
<omvsn>1.3.0</omvsn>
<xm1vsn>20 </xm1vsn>
```

```

<statime>2006.310 23:55:52.034690</statime>
<stotime>2006.310 23:55:52.035318</stotime>
<staseq>BFAAD1C2119824D2</staseq>
<stoseq>BFAAD1C211BF6E52</stoseq>
<rqsttkn1>USRT011 10155552</rqsttkn1>
<rc>02000000C</rc>
<rsn>00003008</rsn>
<rsnmsg>CSLN054I</rsnmsg>
<rsntxt>None of the clients were successful.</rsntxt>
</ctl>
<cmderr>
<mbr name="IMS1 ">
<typ>IMS </typ>
<styp>DBDC </styp>
<rc>0000000C</rc>
<rsn>00003000</rsn>
<rsntxt>At least one request successful</rsntxt>
</mbr>
</cmderr>
<cmd>
<master>IMS1 </master>
<userid>USRT011 </userid>
<verb>DEL </verb>
<kwd>RTC </kwd>
<input>DEL RTC NAME(OLCFR102,GFP1,BADNAME,EMHTX32,EMHTX32) </input>
</cmd>
<cmdrsphdr>
<hdr slbl="RTC" llbl="RtcName" scope="LCL" sort="a" key="1" scroll="no"
len="8" dtype="CHAR" align="left" />
<hdr slbl="MBR" llbl="MbrName" scope="LCL" sort="a" key="2" scroll="no"
len="8" dtype="CHAR" align="left" />
<hdr slbl="CC" llbl="CC" scope="LCL" sort="n" key="0" scroll="yes"
len="4" dtype="INT" align="right" />
<hdr slbl="CCTXT" llbl="CCText" scope="LCL" sort="n" key="0"
scroll="yes" len="32" dtype="CHAR" align="left" skipb="yes" />
</cmdrsphdr>
<cmdrspdata>
<rsp>RTC(OLCFR102) MBR(IMS1) CC( 0) </rsp>
<rsp>RTC(GFP1 ) MBR(IMS1) CC( 39) CCTXT(FP=E TRAN FOR RTC EXISTS)
</rsp>
<rsp>RTC(BADNAME ) MBR(IMS1) CC( 10) CCTXT(NO RESOURCES FOUND) </rsp>
<rsp>RTC(EMHTX32 ) MBR(IMS1) CC( 0) </rsp>
<rsp>RTC(EMHTX32 ) MBR(IMS1) CC( 17) CCTXT(ANOTHER CMD IN PROGRESS)
</rsp>
</cmdrspdata>
</imsout>

```

**Explanation:** A **DELETE RTC** command is issued to delete several Fast Path routing codes from a running IMS system. The delete succeeds for some routing codes, as shown by completion code 0. The delete fails for routing code BADNAME, because no such routing code exists. The delete fails for routing code GFP1, because it was created for a Fast Path exclusive transaction called GFP1 and can only be deleted by a **DELETE TRAN NAME(GFP1)** command. Routing code EMHTX32 is successfully deleted, but routing code EMHTX32 is specified again, which fails because the **DELETE RTC** command is already in progress for EMHTX32.

### Related concepts

[How to interpret CSL request return and reason codes \(System Programming APIs\)](#)

### Related tasks

[Deleting runtime Fast Path routing code resource and descriptor definitions with the DELETE command \(System Definition\)](#)

### Related reference

[“Command keywords and their synonyms” on page 59](#)

All IMS command keywords and their synonyms, as well as keywords supported by the OM API, are listed. The list covers command keywords for the OM command processing clients such as IMS, ODBM, IMSCON, and RM.

## DELETE RTCDESC command

Use the **DELETE RTCDESC** command to delete Fast Path routing code descriptors.

Subsections:

- [“Environment” on page 433](#)
- [“Syntax” on page 433](#)
- [“Keywords” on page 433](#)
- [“Usage notes” on page 433](#)
- [“Output fields” on page 434](#)
- [“Return, reason, and completion codes” on page 434](#)
- [“Examples” on page 436](#)

## Environment

The following table lists the environments (DB/DC, DBCTL, and DCCTL) in which you can use the command and keywords.

*Table 241. Valid environments for the DELETE RTCDESC command and keywords*

| Command / Keywords    | DB/DC | DBCTL | DCCTL |
|-----------------------|-------|-------|-------|
| <b>DELETE RTCDESC</b> | X     |       | X     |
| NAME                  | X     |       | X     |
| OPTION                | X     |       | X     |

## Syntax

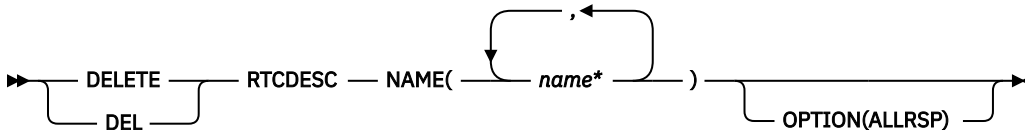

## Keywords

The following keywords are valid for the **DELETE RTCDESC** command:

### NAME

Specifies the 1-8 character name of the routing code descriptor. Wildcards are supported in the name. Examples of valid names are NAME(\*) and NAME(abc\*). If the NAME parameter specified is a specific or wildcard name, command responses are returned for all the descriptor names that are processed. For NAME(\*), command responses are returned only for the descriptor names that resulted in an error. OPTION(ALLRSP) can be specified with NAME(\*) to obtain the command responses for all the descriptor names that are processed.

### OPTION

Specifies additional functions to be performed along with the command.

### ALLRSP

Indicates that the response lines are to be returned for all descriptors that are processed on the command. The default action is to return response lines only for the descriptors that resulted in an error. It is valid only with NAME(\*). ALLRSP is ignored for other NAME values.

## Usage notes

This command can only be issued through the Operations Manager API. This command applies to DB/DC systems and DCCTL systems. The **DELETE RTCDESC** command applies if Fast Path is installed.

The **DELETE RTCDESC** command is not valid on the XRF alternate or FDBR region. The **DELETE RTCDESC** command is not valid if online change for MODBLKS is enabled (DFSDfxxx or DFSCGxxx defined with MODBLKS=OLC or MODBLKS not defined).

This command is recoverable.

Each descriptor is deleted individually. Individual deletion does not work like online change where either all descriptors are deleted or no descriptors are deleted. Descriptors can be successfully deleted if they are not currently in use. If a descriptor is in use, the delete fails. In a sysplex environment, the delete might succeed on some IMS systems and fail on others. A descriptor is in use if another command is in progress that references the descriptor.

The descriptors remain deleted across an IMS warm start or emergency restart. To ensure they remain deleted across a cold start, the existing descriptor definitions must be exported to an RDDS and then imported from the RDDS at cold start.

The IMS-defined routing code descriptor (DBFDSRT1) cannot be deleted with the **DELETE RTCDESC** command.

## Output fields

The following table shows the **DELETE RTCDESC** output fields. The columns in the table are as follows:

### Short label

Contains the short label generated in the XML output.

### Long label

Contains the long label generated in the XML output.

### Keyword

Identifies keyword on the command that caused the field to be generated. N/A appears for output fields that are always returned. *error* appears for output fields that are returned only in case of an error.

### Meaning

Provides a brief description of the output field.

Table 242. Output fields for the **DELETE RTCDESC** command

| Short label | Long label | Keyword      | Meaning  |
|-------------|------------|--------------|--|
| CC          | CC         | N/A          | Completion code.   |
| CCTXT       | CCText     | <i>error</i> | Completion code text that briefly explains the meaning of the non-zero completion code.  |
| DESC        | DescName   | RTCDESC      | Routing code descriptor name.  |
| ERRT        | ErrorText  | <i>error</i> | Error text that provides diagnostic information. Error text can be returned for a non-zero completion code and further explains the completion code. |
| MBR         | MbrName    | N/A          | IMSplex member that built the output line.   |

## Return, reason, and completion codes

The following table includes the return and reason codes and a brief explanation of the codes. The return or reason code returned for the command might also indicate an error from a CSL request.

Table 243. Return and reason codes for the DELETE RTCDESC command

| Return code | Reason code | Meaning   |
|-------------|-------------|---|
| X'00000000' | X'00000000' | Command completed successfully. The command output contains a line for each descriptor, accompanied by its completion code. If NAME(*) is specified without OPTION(ALLRSP), no output lines are returned. See the completion code table for details.  |
| X'0000000C' | X'00003000' | Command was successful for some descriptors but failed for others. The command output contains a line for each descriptor, accompanied by its completion code. If NAME(*) is specified without OPTION(ALLRSP), only descriptors with non-zero completion codes are returned. See the completion code table for details. |
| X'0000000C' | X'00003004' | Command was not successful for any of the descriptors. The command output contains a line for each descriptor, accompanied by its completion code. See the completion code table for details.   |
| X'00000010' | X'0000400C' | Command is not valid on the XRF alternate.  |
| X'00000010' | X'00004024' | No Fast Path defined.   |
| X'00000010' | X'00004120' | Online change phase is in progress.   |
| X'00000010' | X'00004300' | Command is not allowed because online change for MODBLKS is enabled (DFSDFxxx or DFSCGxxx defined with MODBLKS=OLC, or MODBLKS not defined).  |
| X'00000014' | X'00005004' | DFSOCMD response buffer could not be obtained.  |
| X'00000014' | X'00005008' | DFSPPOOL storage could not be obtained.   |
| X'00000014' | X'0000500C' | AWE could not be obtained.  |

Errors unique to the processing of this command are returned as completion codes. The following table includes an explanation of the completion codes.

Table 244. Completion codes for the DELETE RTCDESC command

| Completion code | Completion code text    | Meaning   |
|-----------------|-------------------------|---|
| 0               |                         | Command completed successfully for routing code descriptor.   |
| 10              | NO RESOURCES FOUND      | Routing code descriptor name is invalid, or the wildcard parameter specified does not match any routing code descriptor names.  |
| 17              | ANOTHER CMD IN PROGRESS | Another command (such as <b>DELETE</b> or <b>UPDATE</b> ) is in progress for this routing code descriptor. This could also mean this command, if the descriptor is specified by more than one specific or wildcard parameter. |

Table 244. Completion codes for the DELETE RTCDESC command (continued)

| Completion code | Completion code text            | Meaning  |
|-----------------|---------------------------------|--|
| 27              | REJECTED FOR DEFAULT DESCRIPTOR | <b>DELETE</b> command not allowed for user-defined default descriptor. You must issue an UPDATE command to set another descriptor as the default before deleting this descriptor.                            |
| 48              | NOT ALLOWED FOR IMS RESOURCE    | <b>DELETE</b> command not allowed for IMS descriptor. An example of an IMS descriptor is DBFDSRT1.   |
| 1D7             | IMPORT CHANGE LIST ERROR        | Descriptor is in the process of being imported from the change list in the IMSRSC repository, or the import from the change list failed. The descriptor cannot be deleted until it is successfully imported. |

### Examples

The following are examples of the **DELETE RTCDESC** command:

#### Example 1 for DELETE RTCDESC command

TSO SPOC input:

```
DEL RTCDESC NAME(*) OPTION(ALLRSP)
```

TSO SPOC output:

```
Response for: DEL RTCDESC NAME(*) OPTION(ALLRSP)
DescName MbrName CC CCText
DBFDSRT1 IMS1 48 NOT ALLOWED FOR IMS RESOURCE
DESC001 IMS1 0
DESC002 IMS1 0
DESC003 IMS1 0
DESC004 IMS1 0
DESC005 IMS1 0
RTCDESC1 IMS1 27 REJECTED FOR DEFAULT DESCRIPTOR
```

OM API input:

```
CMD(DEL RTCDESC NAME(*) OPTION(ALLRSP))
```

OM API output:

```
<imsout>
<ctl>
<omname>OM10M </omname>
<omvsn>1.3.0</omvsn>
<xmlvsn>20 </xmlvsn>
<statime>2006.310 22:57:13.782312</statime>
<stotime>2006.310 22:57:13.783073</stotime>
<staseq>BFAAC4A6CD428992</staseq>
<stoseq>BFAAC4A6CD721DC0</stoseq>
<rqsttkn1>USRT011 10145713</rqsttkn1>
<rc>0200000C</rc>
<rsn>00003008</rsn>
<rsnmsg>CSLN054I</rsnmsg>
<rsntxt>None of the clients were successful.</rsntxt>
</ctl>
<cmderr>
<mbr name="IMS1 ">
<typ>IMS </typ>
<styp>DBDC </styp>
```



```

<rc>0000000C</rc>
<rsn>00003000</rsn>
<rsntxt>At least one request successful</rsntxt>
</mbr>
</cmderr>
<cmd>
<master>IMS1 </master>
<userid>USRT011 </userid>
<verb>DEL </verb>
<kwd>RTCDESC </kwd>
<input>DEL RTCDESC NAME(*) OPTION(ALLRSP) </input>
</cmd>
<cmdrspHDR>
<hdr sbl="DESC" llbl="DescName" scope="LCL" sort="a" key="1"
  scroll="no" len="8" dtype="CHAR" align="left" />
<hdr sbl="MBR" llbl="MbrName" scope="LCL" sort="a" key="2" scroll="no"
  len="8" dtype="CHAR" align="left" />
<hdr sbl="CC" llbl="CC" scope="LCL" sort="n" key="0" scroll="yes"
  len="4" dtype="INT" align="right" />
<hdr sbl="CCTXT" llbl="CCText" scope="LCL" sort="n" key="0"
  scroll="yes" len="32" dtype="CHAR" align="left" skipb="yes" />
</cmdrspHDR>
<cmdrspdata>
<rsp>DESC(DESC004 ) MBR(IMS1) CC( 0) </rsp>
<rsp>DESC(DESC005 ) MBR(IMS1) CC( 0) </rsp>
<rsp>DESC(DESC001 ) MBR(IMS1) CC( 0) </rsp>
<rsp>DESC(RTCDESC1) MBR(IMS1) CC( 27) CCTXT(REJECTED FOR DEFAULT
  DESCRIPTOR) </rsp>
<rsp>DESC(DBFDSRT1) MBR(IMS1) CC( 48) CCTXT(NOT ALLOWED FOR IMS
  RESOURCE) </rsp>
<rsp>DESC(DESC002 ) MBR(IMS1) CC( 0) </rsp>
<rsp>DESC(DESC003 ) MBR(IMS1) CC( 0) </rsp>
</cmdrspdata>
</imsout>

```

**Explanation:** A **DELETE RTCDESC** command is issued to delete all routing code descriptors from an active IMS system. Many routing code descriptors are successfully deleted, as indicated by the completion code 0. Because the **DELETE** command attempted to delete all of the routing code descriptors, **OPTION(ALLRSP)** is specified to display the successfully deleted routing code descriptors. Routing code descriptor **RTCDESC1** fails, because it is the default routing code descriptor. Routing code descriptor **DBFDSRT1** fails, because it is the IMS-defined routing code descriptor.

### Related concepts

[How to interpret CSL request return and reason codes \(System Programming APIs\)](#)

### Related reference

[“Command keywords and their synonyms” on page 59](#)

All IMS command keywords and their synonyms, as well as keywords supported by the OM API, are listed. The list covers command keywords for the OM command processing clients such as IMS, ODBM, IMSCON, and RM.

## DELETE TRAN command

Use the **DELETE TRAN** command to delete transactions.

Subsections:

- [“Environment” on page 437](#)
- [“Syntax” on page 438](#)
- [“Keywords” on page 438](#)
- [“Usage notes” on page 438](#)
- [“Output fields” on page 439](#)
- [“Return, reason, and completion codes” on page 440](#)
- [“Examples” on page 442](#)

### Environment

The following table lists the environments (DB/DC, DBCTL, and DCCTL) in which you can use the command and keywords.

Table 245. Valid environments for the DELETE TRAN command and keywords

| Command / Keywords | DB/DC | DBCTL | DCCTL |
|--------------------|-------|-------|-------|
| <b>DELETE TRAN</b> | X     |       | X     |
| NAME               | X     |       | X     |
| OPTION             | X     |       | X     |

## Syntax

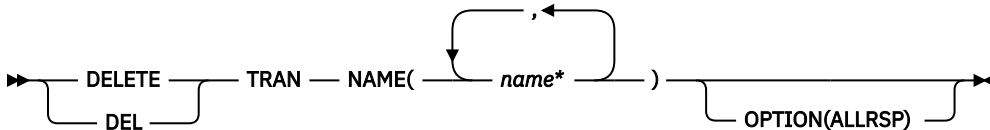

## Keywords

The following keywords are valid for the **DELETE TRAN** command:

### NAME

Specifies the 1-8 character name of the transaction. Wildcards are supported in the name. Examples of valid names are NAME(\*) and NAME(abc\*). If the NAME parameter specified is a specific or wildcard name, command responses are returned for all the resource names that are processed. For NAME(\*), command responses are returned only for the resource names that resulted in an error. OPTION(ALLRSP) can be specified with NAME(\*) to obtain the command responses for all the resource names that are processed.

### OPTION

Specifies additional functions to be performed along with the command.

### ALLRSP

Indicates that the response lines are to be returned for all resources that are processed on the command. The default action is to return response lines only for the resources that resulted in an error. It is valid only with NAME(\*). ALLRSP is ignored for other NAME values.

## Usage notes

This command can only be issued through the OM API. This command applies to DB/DC systems and DCCTL systems.

The **DELETE TRAN** command is not valid on the XRF alternate or FDBR region. The **DELETE TRAN** command is not valid if online change for MODBLKS is enabled (DFSDfxxx or DFSCGxxx defined with MODBLKS=OLC or MODBLKS not defined).

This command is recoverable.

Each transaction is deleted individually, unlike the online change process where either all transactions are deleted or no transactions are deleted. The runtime resource definition for a transaction can only be deleted if the transaction is not in use. If the transaction is in use, the delete fails. In a sysplex environment with multiple IMS systems, the delete might succeed on some IMS systems and fail on others.

The resources remain deleted across an IMS warm start or emergency restart. To ensure that the resources remain deleted across a cold start, the existing resource definitions must be exported to a

system RDDS and then imported from the RDDS at cold start. Or, if the IMSRSC repository is enabled, the **DELETE DEFN** command must be issued to delete the definition from the repository. If the resource definitions are to be imported from the MODBLKS data set at cold start instead of from an RDDS, the resource definitions must be deleted from system definition and a new MODBLKS data set must be generated.

The **DELETE TRAN** command stops all queuing and scheduling of the transaction.

If the transaction is a Fast Path exclusive transaction, the routing code by the same name is deleted as well.

If the **DELETE** command is executed in an IMSplex using Resource Manager (RM) Structures, the transaction is not automatically removed from the structure. To remove the transaction, you can use the IMS Tools Resource Manager Structure utility that is included in IMS Tools Base v1.6 with APAR PH03561 or later. For more information, read the [IMS Tools Resource Manager Structure Utility](#) from the *IMS Tools Base* documentation. You can also use another vendor tool or write an RM client to delete resources from the resource structure.

## Output fields

The following table shows the **DELETE TRAN** output fields. The columns in the table are as follows:

### Short label

Contains the short label generated in the XML output.

### Long label

Contains the long label generated in the XML output.

### Keyword

Identifies keyword on the command that caused the field to be generated. N/A appears for output fields that are always returned. *error* appears for output fields that are returned only in case of an error.

### Meaning

Provides a brief description of the output field.

Table 246. Output fields for the **DELETE TRAN** command

| Short label | Long label | Keyword      | Meaning  |
|-------------|------------|--------------|--|
| CC          | CC         | N/A          | Completion code.   |
| CCTXT       | CCText     | <i>error</i> | Completion code text that briefly explains the nonzero completion code.  |
| CONVID      | ConvID     | TRAN         | Conversation id of conversation associated with transaction that caused the delete to fail with a completion code of C'1A'. This information may be used to exit the conversation, before attempting the delete again. |
| ERRT        | ErrorText  | <i>error</i> | Error text that provides diagnostic information. Error text can be returned for a nonzero completion code and further explains the completion code.  |
| MBR         | MbrName    | N/A          | IMSplex member that built the output line.   |
| LU          | LUName     | TRAN         | APPC LU name associated with the transaction conversation that caused the delete to fail with a completion code of C'1A'. This information may be used to exit the conversation, before attempting the delete again.   |

Table 246. Output fields for the DELETE TRAN command (continued)

| Short label | Long label | Keyword | Meaning   |
|-------------|------------|---------|---|
| NODE        | NodeName   | TRAN    | Node name of static node associated with transaction conversation that caused the delete to fail with a completion code of C'1A'. This information may be used to exit the conversation, before attempting the delete again.      |
| TMEM        | TMember    | TRAN    | OTMA tmember name associated with transaction conversation that caused the delete to fail with a completion code of C'1A'. This information may be used to exit the conversation, before attempting the delete again.             |
| TPIP        | TPipe      | TRAN    | OTMA tpipe name associated with the transaction conversation that caused the delete to fail with a completion code of C'1A'. This information may be used to exit the conversation, before attempting the delete again.           |
| TRAN        | Trancode   | TRAN    | Transaction name.   |
| USER        | UserName   | TRAN    | User name of dynamic user associated with the transaction conversation that caused the delete to fail with a completion code of C'1A'. This information may be used to exit the conversation, before attempting the delete again. |

## Return, reason, and completion codes

The following table includes the return and reason codes and a brief explanation of the codes. The return or reason code returned for the command might also indicate an error from a CSL request.

Table 247. Return and reason codes for the DELETE TRAN command

| Return code | Reason code | Meaning  |
|-------------|-------------|--|
| X'00000000' | X'00000000' | Command completed successfully. The command output contains a line for each resource, accompanied by its completion code. If NAME(*) is specified without OPTION(ALLRSP), no output lines are returned. See the completion code table for details.   |
| X'0000000C' | X'00003000' | Command was successful for some resources but failed for others. The command output contains a line for each resource, accompanied by its completion code. If NAME(*) is specified without OPTION(ALLRSP), only resources with nonzero completion codes are returned. See the completion code table for details. |
| X'0000000C' | X'00003004' | Command was not successful for any of the resources. The command output contains a line for each resource, accompanied by its completion code. See the completion code table for details.  |
| X'00000010' | X'0000400C' | Command is not valid on the XRF alternate.   |
| X'00000010' | X'00004120' | Online change phase is in progress.  |

Table 247. Return and reason codes for the DELETE TRAN command (continued)

| Return code | Reason code | Meaning  |
|-------------|-------------|--|
| X'00000010' | X'00004300' | Command is not allowed because online change for MODBLKS is enabled (DFSDFxxx or DFSCGxxx defined with MODBLKS=OLC, or MODBLKS not defined). |
| X'00000014' | X'00005004' | DFSOCMD response buffer could not be obtained.   |
| X'00000014' | X'00005008' | DFSPPOOL storage could not be obtained.  |
| X'00000014' | X'0000500C' | AWE could not be obtained.   |

Errors unique to the processing of this command are returned as completion codes. The following table includes an explanation of the completion codes.

Table 248. Completion codes for the DELETE TRAN command

| Completion code | Completion code text    | Meaning  |
|-----------------|-------------------------|--|
| 0               |                         | Command completed successfully for transaction.  |
| 10              | NO RESOURCES FOUND      | Transaction name is invalid, or the wildcard parameter specified does not match any transaction names.   |
| 17              | ANOTHER CMD IN PROGRESS | Another command (such as <b>DELETE</b> or <b>UPDATE</b> ) is in progress for this transaction or routing code associated with this transaction, if it is Fast Path exclusive. This could also mean this command, if the resource is specified by more than one specific or wildcard parameter. |
| 1A              | IN CONVERSATION         | Transaction is in conversation.<br><br>The conversation ID and terminal in conversation are returned separately. The terminal can be a static node, node and user, dynamic user, APPC luname, or OTMA tmember and tpie.<br><br>Suggested actions: Terminate the conversation.                  |
| 4A              | IN USE                  | Transaction is in use. Queuing is in progress, either terminal input or a program-to-program switch.   |
| 73              | PROGRAM SCHEDULED       | Program is scheduled.  |
| 85              | SUSPENDED               | Transaction is on the suspend queue.   |
| 87              | TRAN QUEUEING           | Transaction has messages queued (non-shared-queues environment).   |
| 89              | TRAN SCHEDULED          | Transaction is scheduled.  |

Table 248. Completion codes for the DELETE TRAN command (continued)

| Completion code | Completion code text     | Meaning  |
|-----------------|--------------------------|--|
| B3              | ELIGIBLE FOR SCHEDULING  | Transaction is eligible for scheduling and cannot be deleted. You may need to stop the transaction with an <b>UPDATE TRAN STOP(Q,SCHD)</b> command before attempting the <b>DELETE</b> again.            |
| 1D7             | IMPORT CHANGE LIST ERROR | Resource is in the process of being imported from the change list in the IMSRSC repository, or the import from the change list failed. The resource cannot be deleted until it is successfully imported. |

### Examples

The following are examples of the **DELETE TRAN** command:

#### Example 1 for DELETE TRAN command

TSO SPOC input:

```
DEL TRAN NAME(AOP,BADNAME,APOL*,BAD*,AOP)
```

TSO SPOC output:

```
Response for: DEL TRAN NAME(AOP,BADNAME,APOL*,BAD*,AOP)
Trancode MbrName CC CCText
AOP IMS1 0
AOP IMS1 17 ANOTHER CMD IN PROGRESS
APOL11 IMS1 0
APOL12 IMS1 0
APOL13 IMS1 0
APOL14 IMS1 0
APOL15 IMS1 0
APOL16 IMS1 0
APOL17 IMS1 0
APOL18 IMS1 0
BAD* IMS1 10 NO RESOURCES FOUND
BADNAME IMS1 10 NO RESOURCES FOUND
```

OM API input:

```
CMD(DEL TRAN NAME(AOP,BADNAME,APOL*,BAD*,AOP))
```

OM API output:

```
<imsout>
<ctl>
<omname>OM10M </omname>
<omvsn>1.3.0</omvsn>
<xmlvsn>20 </xmlvsn>
<statime>2006.311 00:04:00.354581</statime>
<stotime>2006.311 00:04:00.355454</stotime>
<staseq>BFAAD393C4515645</staseq>
<stoseq>BFAAD393C487EF05</stoseq>
<rqsttkn1>USRT011 10160400</rqsttkn1>
<rc>02000000C</rc>
<rsn>00003008</rsn>
<rsnmsg>CSLN054I</rsnmsg>
<rsntxt>None of the clients were successful.</rsntxt>
</ctl>
<cmderr>
<mbr name="IMS1 ">
<typ>IMS </typ>
<styp>DBDC </styp>
<rc>0000000C</rc>
```

```

<rsn>00003004</rsn>
<rsntxt>No requests were successful</rsntxt>
</mbr>
</cmderr>
<cmd>
<master>IMS1      </master>
<userid>USRT011 </userid>
<verb>DEL </verb>
<kwd>TRAN          </kwd>
<input>DEL TRAN NAME(AOP,BADNAME,APOL*,BAD*,AOP) </input>
</cmd>
<cmdsphdr>
<hdr slbl="TRAN" llbl="Trancode" scope="LCL" sort="a" key="1"
  scroll="no" len="8" dtype="CHAR" align="left" />
<hdr slbl="MBR" llbl="MbrName" scope="LCL" sort="a" key="2" scroll="no"
  len="8" dtype="CHAR" align="left" />
<hdr slbl="CC" llbl="CC" scope="LCL" sort="n" key="0" scroll="yes"
  len="4" dtype="INT" align="right" skipb="no" />
<hdr slbl="CCTXT" llbl="CCText" scope="LCL" sort="n" key="0"
  scroll="yes" len="*" dtype="CHAR" skipb="yes" align="left" />
<hdr slbl="ERRT" llbl="ErrorText" scope="LCL" sort="n" key="0"
  scroll="yes" len="*" dtype="CHAR" skipb="yes" align="left" />
<hdr slbl="CONVID" llbl="ConvID" scope="LCL" sort="n" key="0"
  scroll="yes" len="4" dtype="CHAR" skipb="yes" align="left" />
<hdr slbl="NODE" llbl="NodeName" scope="LCL" sort="n" key="0"
  scroll="yes" len="8" dtype="CHAR" skipb="yes" align="left" />
<hdr slbl="USER" llbl="UserName" scope="LCL" sort="n" key="0"
  scroll="yes" len="8" dtype="CHAR" skipb="yes" align="left" />
<hdr slbl="LU" llbl="LUName" scope="LCL" sort="n" key="0"
  scroll="yes" len="24" dtype="CHAR" skipb="yes" align="left" />
<hdr slbl="TMEM" llbl="TMember" scope="LCL" sort="n" key="0"
  scroll="yes" len="16" dtype="CHAR" skipb="yes" align="left" />
<hdr slbl="TPIP" llbl="TPipe" scope="LCL" sort="n" key="0" scroll="yes"
  len="8" dtype="CHAR" skipb="yes" align="left" />
</cmdsphdr>
<cmdsdata>
<rsp>TRAN(AOP      ) MBR(IMS1) CC(   0) </rsp>
<rsp>TRAN(BADNAME ) MBR(IMS1) CC(  10) CCTXT(NO RESOURCES FOUND) </rsp>
<rsp>TRAN(APOL11  ) MBR(IMS1) CC(   0) </rsp>
<rsp>TRAN(BAD*    ) MBR(IMS1) CC(  10) CCTXT(NO RESOURCES FOUND) </rsp>
<rsp>TRAN(AOP     ) MBR(IMS1) CC(  17) CCTXT(ANOTHER CMD IN PROGRESS)
</rsp>
<rsp>TRAN(APOL12 ) MBR(IMS1) CC(   0) </rsp>
<rsp>TRAN(APOL13 ) MBR(IMS1) CC(   0) </rsp>
<rsp>TRAN(APOL14 ) MBR(IMS1) CC(   0) </rsp>
<rsp>TRAN(APOL15 ) MBR(IMS1) CC(   0) </rsp>
<rsp>TRAN(APOL16 ) MBR(IMS1) CC(   0) </rsp>
<rsp>TRAN(APOL17 ) MBR(IMS1) CC(   0) </rsp>
<rsp>TRAN(APOL18 ) MBR(IMS1) CC(   0) </rsp>
</cmdsdata>
</imsout>

```

**Explanation:** A **DELETE TRAN** command is issued to delete several transactions from a running IMS system. The delete succeeds for some transactions, as shown by completion code 0. The delete fails for transaction BADNAME, because no such transaction exists. The delete fails for transaction name BAD\*, because no transactions start with BAD. Transaction AOP is successfully deleted, but transaction AOP is specified again, which fails because the **DELETE TRAN** command is already in progress for transaction AOP.

### Related concepts

[How to interpret CSL request return and reason codes \(System Programming APIs\)](#)

### Related tasks

[Deleting runtime transaction resource and descriptor definitions with the DELETE command \(System Definition\)](#)

### Related reference

[“Command keywords and their synonyms” on page 59](#)

All IMS command keywords and their synonyms, as well as keywords supported by the OM API, are listed. The list covers command keywords for the OM command processing clients such as IMS, ODBM, IMSCON, and RM.

## DELETE TRANDESC command

Use the **DELETE TRANDESC** command to delete transaction descriptors.

Subsections:

- [“Environment” on page 444](#)
- [“Syntax” on page 444](#)
- [“Keywords” on page 444](#)
- [“Usage notes” on page 445](#)
- [“Output fields” on page 445](#)
- [“Return, reason, and completion codes” on page 446](#)
- [“Examples” on page 447](#)

### Environment

The following table lists the environments (DB/DC, DBCTL, and DCCTL) in which you can use the command and keywords.

Table 249. Valid environments for the DELETE TRANDESC command and keywords

| Command / Keywords     | DB/DC | DBCTL | DCCTL |
|------------------------|-------|-------|-------|
| <b>DELETE TRANDESC</b> | X     |       | X     |
| NAME                   | X     |       | X     |
| OPTION                 | X     |       | X     |

### Syntax

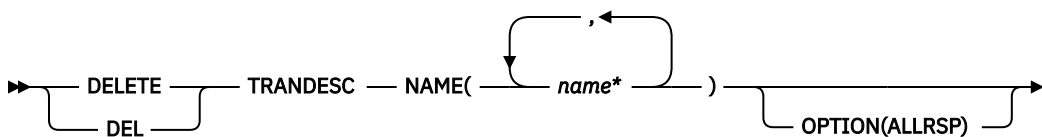

### Keywords

The following keywords are valid for the **DELETE TRANDESC** command:

#### NAME

Specifies the 1-8 character name of the transaction descriptor. Wildcards are supported in the name. Examples of valid names are NAME(\*) and NAME(abc\*). If the NAME parameter specified is a specific or wildcard name, command responses are returned for all the descriptor names that are processed. For NAME(\*), command responses are returned only for the descriptor names that resulted in an error. OPTION(ALLRSP) can be specified with NAME(\*) to obtain the command responses for all the descriptor names that are processed.

#### OPTION

Specifies additional functions to be performed along with the command.



## ALLRSP

Indicates that the response lines are to be returned for all descriptors that are processed on the command. The default action is to return response lines only for the descriptors that resulted in an error. It is valid only with NAME(\*). ALLRSP is ignored for other NAME values.

## Usage notes

This command can only be issued through the Operations Manager API. This command applies to DB/DC systems and DCCTL systems.

The **DELETE TRANDESC** command is not valid on the XRF alternate or FDBR region. The **DELETE TRANDESC** command is not valid if online change for MODBLKS is enabled (DFSDfxxx or DFSCGxxx defined with MODBLKS=OLC or MODBLKS not defined). This command is recoverable.

Each descriptor is deleted individually. Individual deletion does not work like online change where either all descriptors are deleted or no descriptors are deleted. Descriptors can be successfully deleted if they are not currently in use. If a descriptor is in use, the delete fails. In a sysplex environment, the delete might succeed on some IMS systems and fail on others. A descriptor is in use if another command is in progress that references the command.

The descriptors remain deleted across an IMS warm start or emergency restart. To ensure they remain deleted across a cold start, the existing descriptor definitions must be exported to an RDDS and then imported from the RDDS at cold start.

The **DELETE TRANDESC** command is not allowed for IMS descriptors that are identified with a definition type of IMS. For **DELETE TRANDESC** commands, this means IMS transaction descriptor DFSDSTR1.

## Output fields

The following table shows the **DELETE TRANDESC** output fields. The columns in the table are as follows:

### Short label

Contains the short label generated in the XML output.

### Long label

Contains the long label generated in the XML output.

### Keyword

Identifies keyword on the command that caused the field to be generated. N/A appears for output fields that are always returned. *error* appears for output fields that are returned only in case of an error.

### Meaning

Provides a brief description of the output field.

Table 250. Output fields for the DELETE TRANDESC command

| Short label | Long label | Keyword      | Meaning   |
|-------------|------------|--------------|---|
| CC          | CC         | N/A          | Completion code.  |
| CCTXT       | CCText     | <i>error</i> | Completion code text that briefly explains the nonzero completion code.   |
| DESC        | DescName   | TRANDESC     | Transaction descriptor name.  |
| ERRT        | ErrorText  | <i>error</i> | Error text that provides diagnostic information. Error text can be returned for a nonzero completion code and further explains the completion code. |
| MBR         | MbrName    | N/A          | IMSplex member that built the output line.  |

## Return, reason, and completion codes

The following table includes the return and reason codes and a brief explanation of the codes. The return or reason code returned for the command might also indicate an error from a CSL request.

*Table 251. Return and reason codes for the DELETE TRANDESC command*

| Return code | Reason code | Meaning  |
|-------------|-------------|--|
| X'00000000' | X'00000000' | Command completed successfully. The command output contains a line for each descriptor, accompanied by its completion code. If NAME(*) is specified without OPTION(ALLRSP), no output lines are returned. See the completion code table for details.   |
| X'0000000C' | X'00003000' | Command was successful for some descriptors but failed for others. The command output contains a line for each descriptor, accompanied by its completion code. If NAME(*) is specified without OPTION(ALLRSP), only descriptors with nonzero completion codes are returned. See the completion code table for details. |
| X'0000000C' | X'00003004' | Command was not successful for any of the descriptors. The command output contains a line for each descriptor, accompanied by its completion code. See the completion code table for details.  |
| X'00000010' | X'0000400C' | Command is not valid on the XRF alternate.   |
| X'00000010' | X'00004120' | Online change phase is in progress.  |
| X'00000010' | X'00004300' | Command is not allowed because online change for MODBLKS is enabled (DFSDFxxx or DFSCGxxx defined with MODBLKS=OLC, or MODBLKS not defined).   |
| X'00000014' | X'00005004' | DFSOCMD response buffer could not be obtained.   |
| X'00000014' | X'00005008' | DFSPPOOL storage could not be obtained.  |
| X'00000014' | X'0000500C' | AWE could not be obtained.   |

Errors unique to the processing of this command are returned as completion codes. The following table includes an explanation of the completion codes.

*Table 252. Completion codes for the DELETE TRANDESC command*

| Completion code | Completion code text    | Meaning  |
|-----------------|-------------------------|--|
| 0               |                         | Command completed successfully for transaction descriptor.   |
| 10              | NO RESOURCES FOUND      | Transaction descriptor name is invalid, or the wildcard parameter specified does not match any transaction descriptor names.   |
| 17              | ANOTHER CMD IN PROGRESS | Another command (such as <b>DELETE</b> or <b>UPDATE</b> ) is in progress for this transaction descriptor. This could also mean this command, if the descriptor is specified by more than one specific or wildcard parameter. |

Table 252. Completion codes for the DELETE TRANDESC command (continued)

| Completion code | Completion code text            | Meaning  |
|-----------------|---------------------------------|--|
| 27              | REJECTED FOR DEFAULT DESCRIPTOR | <b>DELETE</b> command not allowed for user-defined default descriptor. You must issue an <b>UPDATE</b> command to set another descriptor as the default before deleting this descriptor.                     |
| 48              | NOT ALLOWED FOR IMS RESOURCE    | <b>DELETE</b> command not allowed for IMS descriptor. An example of an IMS descriptor is DFSDSTR1.   |
| 1D7             | IMPORT CHANGE LIST ERROR        | Descriptor is in the process of being imported from the change list in the IMSRSC repository, or the import from the change list failed. The descriptor cannot be deleted until it is successfully imported. |

### Examples

The following are examples of the **DELETE TRANDESC** command:

#### Example 1 for DELETE TRANDESC command

TSO SPOC input:

```
DEL TRANDESC NAME(*) OPTION(ALLRSP)
```

TSO SPOC output:

```
Response for: DEL TRANDESC NAME(*) OPTION(ALLRSP)
DescName MbrName CC CCText
CONVDESC IMS1 0
DESC001 IMS1 0
DESC002 IMS1 0
DESC003 IMS1 0
DESC004 IMS1 0
DESC005 IMS1 0
DESC101 IMS1 0
DESC102 IMS1 0
DESC103 IMS1 0
DESC104 IMS1 0
DESC105 IMS1 0
DESC201 IMS1 0
DESC202 IMS1 0
DESC203 IMS1 0
DESC204 IMS1 0
DESC205 IMS1 0
DFSDSTR1 IMS1 48 NOT ALLOWED FOR IMS RESOURCE
FPEDESC IMS1 27 REJECTED FOR DEFAULT DESCRIPTOR
FPPDESC IMS1 0
MSCDESC IMS1 0
```

OM API input:

```
CMD(DEL TRANDESC NAME(*) OPTION(ALLRSP))
```

OM API output:

```
<imsout>
<ctl>
<omname>OM10M </omname>
<omvsn>1.3.0</omvsn>
<xmlvsn>20 </xmlvsn>
<statime>2006.310 22:43:49.648480</statime>
```

```

<stotime>2006.310 22:43:49.650611</stotime>
<staseq>BFAAC1A7EB860302</staseq>
<stoseq>BFAAC1A7EC0B37D2</stoseq>
<rqsttkn1>USRT011 10144349</rqsttkn1>
<rc>0200000C</rc>
<rsn>00003008</rsn>
<rsnmsg>CSLN054I</rsnmsg>
<rsntxt>None of the clients were successful.</rsntxt>
</ctl>
<cmderr>
<mbr name="IMS1 ">
<typ>IMS </typ>
<styp>DBDC </styp>
<rc>0000000C</rc>
<rsn>00003004</rsn>
<rsntxt>No requests were successful</rsntxt>
</mbr>
</cmderr>
<cmd>
<master>IMS1 </master>
<userid>USRT011 </userid>
<verb>DEL </verb>
<kwd>TRANDESC </kwd>
<input>DEL TRANDESC NAME(*) OPTION(ALLRSP) </input>
</cmd>
<cmdrsphdr>
<hdr slbl="DESC" llbl="DescName" scope="LCL" sort="a" key="1"
  scroll="no" len="8" dtype="CHAR" align="left" />
<hdr slbl="MBR" llbl="MbrName" scope="LCL" sort="a" key="2" scroll="no"
  len="8" dtype="CHAR" align="left" />
<hdr slbl="CC" llbl="CC" scope="LCL" sort="n" key="0" scroll="yes"
  len="4" dtype="INT" align="right" skipb="no" />
<hdr slbl="CCTXT" llbl="CCText" scope="LCL" sort="n" key="0"
  scroll="yes" len="*" dtype="CHAR" skipb="yes" align="left" />
<hdr slbl="ERRT" llbl="ErrorText" scope="LCL" sort="n" key="0"
  scroll="yes" len="*" dtype="CHAR" skipb="yes" align="left" />
<hdr slbl="CONVID" llbl="ConvID" scope="LCL" sort="n" key="0"
  scroll="yes" len="4" dtype="CHAR" skipb="yes" align="left" />
<hdr slbl="NODE" llbl="NodeName" scope="LCL" sort="n" key="0"
  scroll="yes" len="8" dtype="CHAR" skipb="yes" align="left" />
<hdr slbl="USER" llbl="UserName" scope="LCL" sort="n" key="0"
  scroll="yes" len="8" dtype="CHAR" skipb="yes" align="left" />
<hdr slbl="LU" llbl="LUName" scope="LCL" sort="n" key="0"
  scroll="yes" len="24" dtype="CHAR" skipb="yes" align="left" />
<hdr slbl="TMEM" llbl="TMember" scope="LCL" sort="n" key="0"
  scroll="yes" len="16" dtype="CHAR" skipb="yes" align="left" />
<hdr slbl="TPIP" llbl="TPipe" scope="LCL" sort="n" key="0" scroll="yes"
  len="8" dtype="CHAR" skipb="yes" align="left" />
</cmdrsphdr>
<cmdrspdata>
<rsp>DESC(DESC102 ) MBR(IMS1) CC( 0) </rsp>
<rsp>DESC(DESC004 ) MBR(IMS1) CC( 0) </rsp>
<rsp>DESC(DESC205 ) MBR(IMS1) CC( 0) </rsp>
<rsp>DESC(DFSDSTR1) MBR(IMS1) CC( 48) CCTXT(NOT ALLOWED FOR IMS
  RESOURCE) </rsp>
<rsp>DESC(DESC201 ) MBR(IMS1) CC( 0) </rsp>
<rsp>DESC(FPPDESC ) MBR(IMS1) CC( 0) </rsp>
<rsp>DESC(DESC103 ) MBR(IMS1) CC( 0) </rsp>
<rsp>DESC(DESC005 ) MBR(IMS1) CC( 0) </rsp>
<rsp>DESC(DESC001 ) MBR(IMS1) CC( 0) </rsp>
<rsp>DESC(DESC202 ) MBR(IMS1) CC( 0) </rsp>
<rsp>DESC(DESC104 ) MBR(IMS1) CC( 0) </rsp>
<rsp>DESC(CONVDESC) MBR(IMS1) CC( 0) </rsp>
<rsp>DESC(DESC002 ) MBR(IMS1) CC( 0) </rsp>
<rsp>DESC(DESC203 ) MBR(IMS1) CC( 0) </rsp>
<rsp>DESC(MSCDESC ) MBR(IMS1) CC( 0) </rsp>
<rsp>DESC(DESC105 ) MBR(IMS1) CC( 0) </rsp>
<rsp>DESC(DESC101 ) MBR(IMS1) CC( 0) </rsp>
<rsp>DESC(FPEDESC ) MBR(IMS1) CC( 27) CCTXT(REJECTED FOR DEFAULT
  DESCRIPTOR) </rsp>
<rsp>DESC(DESC003 ) MBR(IMS1) CC( 0) </rsp>
<rsp>DESC(DESC204 ) MBR(IMS1) CC( 0) </rsp>
</cmdrspdata>
</imsout>

```

**Explanation:** A **DELETE TRANDESC** command is issued to delete all transaction descriptors from an active IMS system. Many transaction descriptors are successfully deleted, as indicated by the completion code 0. Because the **DELETE** command attempted to delete all of the transaction descriptors, **OPTION(ALLRSP)** is specified to display the successfully deleted transaction descriptors. The delete for

transaction descriptor FPEDESC fails, because it is the default transaction descriptor. The delete for transaction descriptor DFSDSTR1 fails, because it is the IMS-defined transaction descriptor.

**Related concepts**

[How to interpret CSL request return and reason codes \(System Programming APIs\)](#)

**Related reference**

[“Command keywords and their synonyms” on page 59](#)

All IMS command keywords and their synonyms, as well as keywords supported by the OM API, are listed. The list covers command keywords for the OM command processing clients such as IMS, ODBM, IMSCON, and RM.



## Chapter 24. /DEQUEUE command

The **/DEQUEUE** command with any of the following keywords is used to cancel a message that is being processed: LINE, LTERM, LUNAME, MSNAME, NODE, TRAN, or USER.

Also, a **/DEQUEUE** command dequeues messages from either the local queues, or in a shared-queues environment, the shared queues. An output message displays the total count of all messages dequeued.

Subsections:

- [“Environment” on page 451](#)
- [“Syntax” on page 451](#)
- [“Keywords” on page 452](#)
- [“Usage notes” on page 456](#)
- [“Examples” on page 456](#)

### Environment

The following table lists the environments (DB/DC, DBCTL, and DCCTL) in which you can use the command and keywords.

*Table 253. Valid environments for the /DEQUEUE command and keywords*

| Command / Keywords | DB/DC | DBCTL | DCCTL |
|--------------------|-------|-------|-------|
| /DEQUEUE           | X     | X     | X     |
| AOITKN             | X     | X     | X     |
| LINE               | X     |       | X     |
| LTERM              | X     |       | X     |
| LUNAME             | X     |       | X     |
| MSNAME             | X     |       | X     |
| NODE               | X     |       | X     |
| PTERM              | X     |       | X     |
| PURGE              | X     |       | X     |
| PURGE1             | X     |       | X     |
| SUSPEND            | X     |       | X     |
| TMEM               | X     |       | X     |
| TPIPE              | X     |       | X     |
| TPNAME             | X     |       | X     |
| TRAN               | X     |       | X     |
| USER               | X     |       | X     |

### Syntax

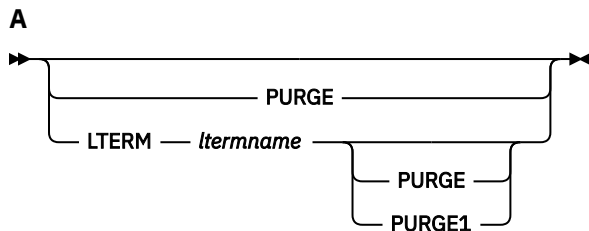
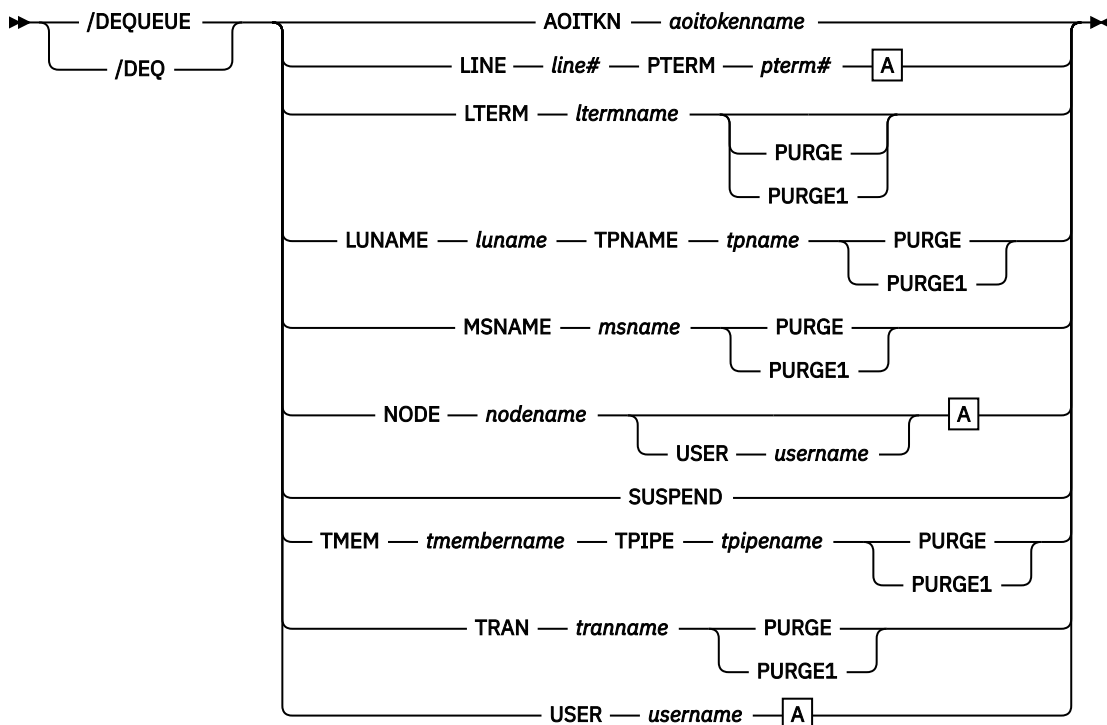

## Keywords

The following keywords are valid for the **/DEQUEUE** command:

### AOITOKEN

Dequeues and discards all messages associated with the specified AOI token name.

### LINE PTERM

Cancels the output message currently being sent to the specified physical terminal on the specified communication line.

### LTERM

Cancels the output message currently being sent to the specified logical terminal.

**/DEQUEUE NODE nodename LTERM** is not valid for nodes with users. The user that contains the LTERM must be allocated and the session must be active.

If the PURGE or PURGE1 keyword is specified and the LTERM is associated with a user with DEADQ status, the DEADQ status will be reset.

If the DEADQ status is on, the following command turns it off for the user associated with LTERM ltermname:

```
/DEQUEUE LTERM ltermname (PURGE/PURGE1)
```

The DEADQ status is removed by signing the user on or by issuing the **/DEQUEUE** command to dequeue one or more messages.



**Important:** Both the USER and the LTERM blocks must exist in either the IMS system or the Resource Manager (RM) resource structure. Otherwise, a DFS189 error message might occur when the **/DEQUEUE LTERM ltermname (PURGE/PURGE1)** command is issued for a dynamic LTERM in a shared-queue environment with STM=YES specified. To solve this problem, see the instructions in [DFS189 \(Messages and Codes\)](#).

When the **/DEQUEUE LTERM ltermname (PURGE/PURGE1)** command is successfully completed, issue a **/START USER** command to reset the user status so that the user structure can be deleted at the next checkpoint.

### LUNAME TPNAME

Specifies the LU name and TP name of the LU 6.2 destination from which messages are discarded. A normal (non-qualified) or fully network qualified LUNAME is required for the LUNAME keyword.

**Note:** A fully qualified LU name must be specified in single quotation marks.

Either the PURGE or PURGE1 option must be specified, and the LU 6.2 destination must be stopped and not active; if both actions are not taken, error messages are issued.

In a shared-queues environment, only messages that are owned by the command processing IMS are dequeued. Inflight synchronous output messages are not dequeued. Any stranded synchronous output messages with affinity to the command processing IMS are dequeued.

If you used a side information entry name to place messages on the queues, to dequeue those messages, specify the side information entry name for the LU name and the character string DFSSIDE for the TP name.

### MSNAME

Cancels the output message currently being sent to the specified MSC link. Either PURGE or PURGE1 is required for this link. The MSC link must be stopped by the **/PSTOP LINK** command before issuing the **/DEQUEUE MSNAME** command.

### NODE

Cancels the output message currently being sent to the specified VTAM node.

The following command is not valid for nodes with users:

```
/DEQUEUE NODE nodename
```

```
/DEQUEUE NODE nodename LTERM ltermname
```

The following command cancels the output message currently being sent to the specified ISC session, and the user must be allocated to the node and the session must be active:

```
/DEQUEUE NODE nodename USER useiname
```

### Restrictions for using NODE and USER parameters together:

- Commands with the NODE USER keyword pair are valid only if:
  - The USER is signed on to the NODE
  - In an ISC environment, the USER is allocated to the NODE
  - The nodes and users already exist
- **/DEQUEUE NODE USER LTERM** commands are valid for ISC and non-ISC nodes and users.
- **/DEQUEUE NODE USER PURGE** commands and **/DEQUEUE NODE USER LTERM PURGE1** commands are valid for ISC, LUP, and 3600 nodes only.

If PURGE or PURGE1 is specified, the node must be stopped and idle. Without PURGE and PURGE1, if an ETO node or an ISC static parallel session, the USER keyword is required.

If the PURGE keyword is specified, and the NODE is associated with a user with DEADQ status, the DEADQ status will be reset.

## PURGE

Cancels all output messages enqueued to the specified LINE, LTERM, LUNAME, MSNAME, NODE, TMEM, TPIPE, or USER. The PURGE keyword allows cancellation of all output messages enqueued to an LTERM, or to a PTERM without regard to the LTERM. A **/DEQUEUE** command without PURGE cancels an in-progress output message on the specified terminal and, optionally, LTERM. If the NODE and LTERM keywords have both been supplied, the LTERM must be a valid LTERM of the user currently associated with the node.

Messages cannot be canceled with PURGE if they are destined for the MTO or for terminals or users in response mode or conversation mode. The **/DEQUEUE PURGE** command does not cancel messages destined for the master terminal operator because the master terminal cannot be stopped, disconnected, or idled. The **/EXIT** command should be used for a terminal in conversation mode.

If the terminal is a dynamic 3600/FINANCE, SLU P, or ISC terminal, the NODE keyword is valid only if the session is stopped and idle, and the LTERMs are still allocated to the terminal pending message resynchronization. For example, the following command is valid for the allocated user only if the specified ISC session is stopped and idled.

```
/DEQUEUE NODE nodename USER username (LTERM ltermname) PURGE
```

Messages queued to LTERMs associated with users that are not signed on can be purged by specifying the LTERM keyword without the NODE keyword. NODE with the USER keyword applies to ISC sessions and dynamic terminals and is valid only if the user is still allocated to the node. However, the line or node must be stopped and idled.

If USER is specified and the user had DEADQ status, the DEADQ status is removed. If LTERM or NODE is specified and the LTERM or node is associated with a user with DEADQ status, the DEADQ status is removed.

## PURGE1

Cancels the first message queued to the specified LTERM. The PURGE1 and PURGE keywords are mutually exclusive.

The **/DEQUEUE LTERM PURGE1** command removes the first message from the queue. The order of search for messages to be removed is:

1. Fast Path
2. Response mode
3. Exclusive mode messages
4. System messages
5. All other messages

Using a synonym for PURGE1 avoids the potential danger of omitting the trailing digit on PURGE1 and canceling all the messages enqueued. Synonyms for PURGE1 are SINGLE, SNGL, and FIRST.

When PURGE1 is specified, the terminal must be stopped and idle and not in conversation mode. If the message is in the process of being actively sent, The **/DEQUEUE** command without PURGE1 cancels the message.

## SUSPEND

Reschedules transactions that have been suspended by IMS. SUSPEND applies to IMS systems sharing data at the block level and to connected external subsystems (not CCTL subsystems). The **/DEQUEUE SUSPEND** command causes all message-driven transactions that have been suspended to be rescheduled. When a failed IMS system is restarted, the **/DEQUEUE SUSPEND** command informs the currently running IMS system to reschedule any message-driven transactions on its SUSPEND queue. However, when the failed subsystem has global locks retained and cannot communicate the release of those locks to the other subsystems, the **/DEQUEUE SUSPEND** command is used to reschedule these message-driven transactions in the other subsystems. This can occur when:

- The still-running IMS has transactions on its SUSPEND queue and the failed IMS has been restarted using the **/ERESTART COLDSYS** command.

- The still-running IMS terminates before the failed IMS is restarted. Thus, when the failed system is restarted, the other system, which has now terminated, is unable to receive the message to reschedule the transactions on its SUSPEND queue. The operator must issue the **/DEQUEUE SUSPEND** command to reschedule them.

Another use for the **/DEQUEUE SUSPEND** command is to release those transactions queued because the installation specified the requeue region error option in the external subsystem PROCLIB member for a particular subsystem. Transactions will be queued if the subsystem connection terminates in an abnormal fashion (for example, dependent region abend, subsystem abnormal termination).

In a shared-queues environment, a **/DEQUEUE SUSPEND** command moves all transactions on the Transaction Suspend queue to the Transaction Ready queue and makes them eligible for rescheduling. The "suspend" status for the transactions is also reset locally (on the IMS subsystem that entered the command), but is not reset across the sysplex. To reset the "suspend" status across a sysplex, use the **/START TRAN** command on each IMS subsystem.

You can also use the **/START TRAN** command to reschedule a specific transaction that has been suspended.

The **/DISPLAY TRAN** and **/DISPLAY STATUS** commands can be used to determine whether a transaction has messages on its suspend queue.

### TMEM TPIPE

Dequeues messages from the specified IMS Open Transaction Manager Access (OTMA) member and transaction pipe. Using the **/DEQ** command can make OTMA message resynchronization impossible. If resynchronization is in progress for the specified transaction pipe, IMS rejects the command and issues message DFS2392I.

In a shared-queues environment, only messages that are owned by the command processing IMS are dequeued. Inflight synchronous output messages are not dequeued. Any stranded synchronous output messages with affinity to the command processing IMS are dequeued.

### TRAN

Dequeues one or more messages from the transaction specified. The transaction name is a 1- to 8-byte name. The transaction must be stopped for messages to be dequeued.

**Restriction:** This keyword is valid only in a shared-queues environment. In a non-shared-queues environment, the equivalent type-2 commands **QUEUE TRAN NAME(xxxx) OPTION(DEQ1)** and **QUEUE TRAN NAME(xxxx) OPTION(DEQALL)** are valid. To learn more, see [QUEUE TRAN command \(Commands\)](#).

**Recommendation:** Stop the transaction on all IMS subsystems in the shared queues group before issuing the **/DEQUEUE TRAN** command. If you do not, the IMS subsystem that processes the **/DEQUEUE** could dequeue a message it does not own and that another IMS subsystem might need.

A **/DEQUEUE TRAN** command does not dequeue messages enqueued for suspended transactions.

In a shared-queues environment, a **/DEQUEUE TRAN** command can dequeue transaction messages queued to the transaction from APPC or OTMA Clients. The command only dequeues the transaction messages. The APPC or OTMA transaction instance blocks (TIB) created at the IMS system are not deleted and the storage may remain allocated until the next IMS restart. For APPC, the TIB is not released and the APPC conversation (the client) hangs if there is no timeout value specified. The **APPCIoT=(x,Y)** timeout value for APPC would deallocate the APPC conversation and release the TIB after the timeout limit has been reached.

### USER (LTERM)

Dequeues all messages associated with all LTERMs (or a specific) LTERM assigned to that USER. The user must be stopped and not in conversation in order to enter **/DEQUEUE USER** with PURGE and PURGE1. The **/DEQUEUE USER** command with PURGE1 or the **/DEQUEUE USER LTERM** command without PURGE or PURGE1 requires the LTERM keyword. If a user is signed on, the **/DEQUEUE USER LTERM** command can be used to cancel an output message that is currently being processed. When the purge options are used, messages destined for the MTO and users in response mode, Fast Path, and conversation cannot be canceled. If the USER and LTERM keywords have both been supplied, the LTERM must be a valid LTERM of the specified USER.

If the user has DEADQ status, the DEADQ status is removed.

## Usage notes

The **DEQUEUE** command dequeues messages from an OTMA transaction pipe. CMO output messages can be placed on the OTMA tpipe using multiple output queue names. A different queue name is used to queue I/O PCB output messages than is used to queue hold queue messages. In the non-super member environment, a CMO output message could be on the I/O PCB output queue or the member's tpipe hold queue. In the super member environment, a CMO output message could be on I/O PCB output queue or the super member hold queue.

If the member specified is a regular member, CMO output messages are dequeued from the member's tpipe hold queue and the member's I/O PCB output queue. If the member specified is a super member, CMO output messages are dequeued from the super member's output hold queue. The number of messages dequeued depends on whether PURGE or PURGE1 is specified. In the non-shared-queues environment, if the member specified is a regular member, messages are dequeued from the regular member's hold queue first, then from the regular member's I/O PCB output queue. In the shared-queues environment the order in which messages for the same destination are dequeued is not guaranteed. Hold queue messages may be dequeued before I/O PCB output messages one time and I/O PCB output messages may be dequeued before hold queue messages the next.

If IMS cold starts and messages are queued to the same tpipe destination following the cold start, a new set of queue names is used to queue I/O PCB output messages and hold queue messages. In the shared-queues environment with super member enabled, all messages queued to a super member, are placed on the shared queues using the same queue name, even after a cold start of IMS. Messages on the super member's output queue do not have affinity to any IMS. They can be dequeued from any IMS in the IMSplex.

This command can be issued to an IMSplex using the Batch SPOC utility.

A **/DEQUEUE** command with any of the following keywords activates the Message Control Error exit routine, DFSCMUX0, before processing each message: LTERM, LUNAME TPNAME, NODE, or MSNAME. The user exit routine can request IMS to:

- Proceed with the command and purge the message. This is the default action for the Message Control Error exit routine.
- Suppress the command.
- Suppress the command and send an informational message to the entering terminal.
- Route the message to a different destination.

The **/DEQUEUE NODE** command dequeues messages from the local or shared queues for statically defined terminals. Without PURGE or PURGE1, the message actively being sent is dequeued.

The **/DEQUEUE LTERM** command dequeues messages from the local or shared queues. The user must be stopped (by a **/STOP USER** command), and not in conversation, in order to enter **/DEQUEUE USER** or **/DEQUEUE LTERM** with PURGE or PURGE1. In a shared queues and ETO environment where the user does not exist, **/DEQUEUE LTERM** with PURGE or PURGE1 creates a user structure in order to dequeue messages from the shared queues.

## Examples

The following are examples of the **/DEQUEUE** command:

### **Example 1 for /DEQUEUE command**

Entry ET:

```
/DEQUEUE AOITOKEN ABCDE
```

Response ET:

```
DFS058I DEQUEUE COMMAND COMPLETED
```

Explanation: The messages on AOITOKEN ABCDE are dequeued and discarded.

**Example 2 for /DEQUEUE command**

Entry ET:

```
/DEQUEUE LINE 5 PTERM 2
```

Response ET:

```
DFS058I DEQUEUE COMMAND COMPLETED
```

Explanation: The message is terminated on successful completion of the current transmission.

**Example 3 for /DEQUEUE command**

Entry ET:

```
/DEQUEUE LTERM ABCDE PURGE
```

Response ET:

```
DFS976I 2 MESSAGE(S) PURGED
```

Explanation: Two messages are dequeued for LTERM ABCDE (the line is stopped and idle as required).

**Example 4 for /DEQUEUE command**

Entry ET:

```
/DEQUEUE LTERM ABCDE PURGE1
```

Response ET:

```
DFS058I DEQUEUE COMMAND COMPLETED
```

Explanation: The message is dequeued for LTERM ABCDE.

**Example 5 for /DEQUEUE command**

Entry ET:

```
/DEQ LUNAME 'NETWORK1.LUNAME1' TPNAME TPNAME1 PURGE
```

Response ET:

```
DFS1952 10:51:35 DESTINATION NOT FOUND
```

Explanation: An invalid APPC destination was entered.

**Example 6 for /DEQUEUE command**

Entry ET:

```
/DEQ LUNAME 'CICSNET.SERVER1' TPNAME DFSASYNCR PURGE1
```

Response ET:

```
DFS976I 14:10:25 1 MESSAGE(S) PURGED
```

Explanation: The message was dequeued from the APPC destination LUNAME CICSNET.SERVER, TPNAME DFSASYNC.

**Related reference**

[“Command keywords and their synonyms” on page 59](#)

All IMS command keywords and their synonyms, as well as keywords supported by the OM API, are listed. The list covers command keywords for the OM command processing clients such as IMS, ODBM, IMSCON, and RM.

---

## Chapter 25. /DFSTCF LOAD command

You can process a new time-controlled operation (TCO) script without stopping (and restarting) IMS or TCO by sending a message switch to the TCO LTERM, DFSTCF. An operator, a program, or an exit routine can issue the command to load a new script.

When you loaded a new script, and IMS processes it, IMS disregards all previous schedule requests. Being able to load TCO scripts dynamically allows you to do these tasks:

- Change or correct TCO scripts without stopping IMS
- Chain multiple scripts, so that they are processed on different days

For more information on the command format and parameters, see [LOAD command and processing a TCO script \(Operations and Automation\)](#).

### **Related reference**

[“Command keywords and their synonyms” on page 59](#)

All IMS command keywords and their synonyms, as well as keywords supported by the OM API, are listed. The list covers command keywords for the OM command processing clients such as IMS, ODBM, IMSCON, and RM.





## Chapter 26. /DIAGNOSE commands

Use the **/DIAGNOSE SNAP** command to retrieve diagnostic information for system resources such as IMS control blocks, user-defined nodes, or user-defined transactions at any time without creating a console dump. Use the **/DIAGNOSE SET** command to enable or disable diagnostic features such as the logging facility that captures events related to APPC and OTMA synchronous transactions in a shared-queues environment.

The SET and SNAP keywords are mutually exclusive.

### Related concepts

[/DIAGNOSE command SNAP function \(Diagnosis\)](#)

## /DIAGNOSE SET command

Use the **/DIAGNOSE SET** command to enable or disable diagnostic features such as the logging facility that captures events related to APPC and OTMA synchronous transactions in a shared-queues environment.

Subsections:

- [“Environment” on page 461](#)
- [“Syntax” on page 461](#)
- [“Keywords” on page 461](#)
- [“Examples” on page 462](#)

### Environment

The following table lists the environments (DB/DC, DBCTL, and DCCTL) from which the command can be issued.

Table 254. Valid environments for the /DIAGNOSE SET command and keywords

| Command / Keywords   | DB/DC | DBCTL | DCCTL |
|----------------------|-------|-------|-------|
| <b>/DIAGNOSE SET</b> | X     | X     | X     |
| AOSLOG               | X     |       | X     |
| SYSOUT               | X     | X     | X     |

### Syntax

```
→ /DIAGNOSE SET AOSLOG( ON ) SYSOUT( ON ) →  
   /DIAG OFF OFF
```

### Keywords

You can use the **/DIAGNOSE SET** command to change the values of various IMS diagnostic options. The option to change is identified by the command keyword, and the desired state of the option is specified by the keyword value. For detailed information about option processing, see the specific keyword documentation. The SET keyword is mutually exclusive with the SNAP keyword.

The following keywords are valid for the **/DIAGNOSE SET** command:

## AOSLOG

Specifies whether events related to APPC and OTMA synchronous transactions in a shared-queues environment are logged. Logged events are written to the OLDS as type X'6701' records.

If AOSLOG(ON) is specified in a non-shared-queues environment or when AOS=N is specified in the DFSDCxxx PROCLIB member, the command is rejected with a DFS2859I message.

### ON

Enables AOS logging.

### OFF

Disables AOS logging.

## SYSOUT

Enables or disables SYSOUT processing by the Diagnostic Services AWE server. If enabled, SYSOUT requests that are queued to the Diagnostic Services AWE server by the **/DIAGNOSE** command SYSOUT option are processed, and **/DIAGNOSE SNAP** command output is written to a SYSOUT data set. If disabled, SYSOUT requests that are queued to the Diagnostic Services AWE server are rejected.

### ON

Enables SYSOUT processing by the Diagnostic Services AWE server.

### OFF

Disables SYSOUT processing by the Diagnostic Services AWE server.

## Examples

The following example shows the **/DIAGNOSE SET** command.

Entry ET:

```
/DIAGNOSE SET AOSLOG(ON)
```

Response ET:

```
DFS058I DIAGNOSE COMMAND COMPLETED
```

**Explanation:** The logging of events related to APPC and OTMA synchronous transactions in the shared-queues environment is enabled. The X'6701' records are captured and written to the IMS log.

### Related information

[DFS2859I \(Messages and Codes\)](#)

## **/DIAGNOSE SNAP** command

---

Use the **/DIAGNOSE SNAP** command to capture storage information, and then format and display that information on the issuing LTERM. Optionally, the information can be written to the OLDS, trace data sets as type X'6701' records, or a SYSOUT data set. Storage information can be captured for IMS control blocks, user-defined nodes, transactions, programs, and database resources.

Subsections:

- [“Environment” on page 462](#)
- [“Syntax” on page 463](#)
- [“Keywords” on page 466](#)
- [“Usage notes” on page 493](#)
- [“Examples” on page 494](#)

## Environment

The following table lists the environments (DB/DC, DBCTL, and DCCTL) from which the command can be issued.

*Table 255. Valid environments for the /DIAGNOSE SNAP command and keywords*

| Command / Keywords    | DB/DC | DBCTL | DCCTL |
|-----------------------|-------|-------|-------|
| <b>/DIAGNOSE SNAP</b> | X     | X     | X     |
| ADDRESS               | X     | X     | X     |
| AREA                  | X     | X     |       |
| BLOCK                 | X     | X     | X     |
| DB                    | X     | X     |       |
| JOBNAME               | X     | X     | X     |
| LINE                  | X     |       | X     |
| LINK                  | X     |       | X     |
| LTERM                 | X     |       | X     |
| MODULE                | X     | X     | X     |
| MSNAME                | X     |       | X     |
| NODE                  | X     |       | X     |
| OPTION                | X     | X     | X     |
| PGM                   | X     | X     | X     |
| REGION                | X     | X     | X     |
| RM                    | X     |       | X     |
| SHOW                  | X     | X     | X     |
| STRUCTURE             | X     |       | X     |
| TRAN                  | X     |       | X     |
| USER                  | X     |       | X     |

## Syntax

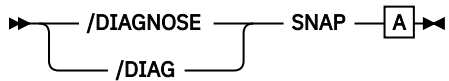

**A**

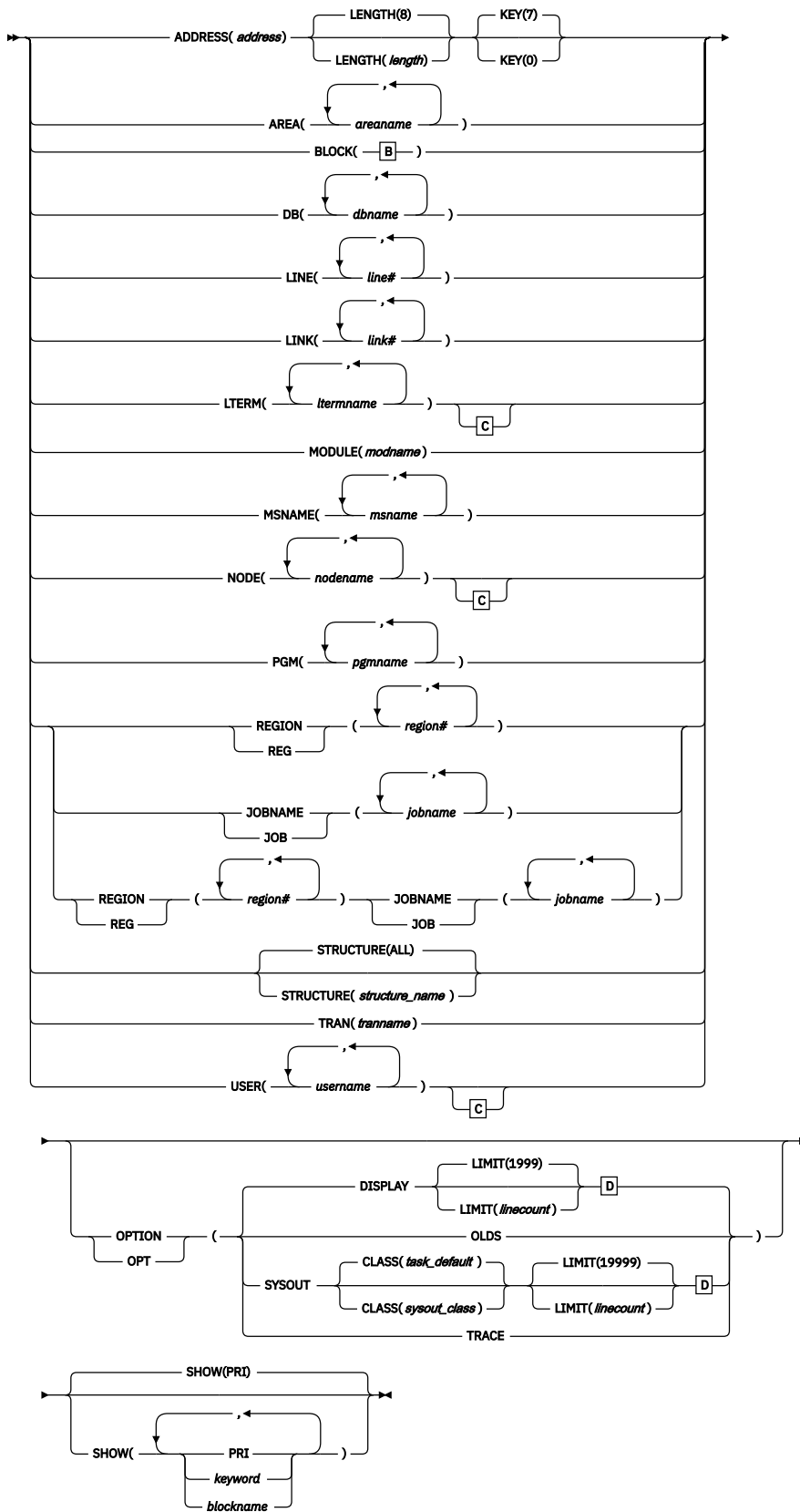

**B**

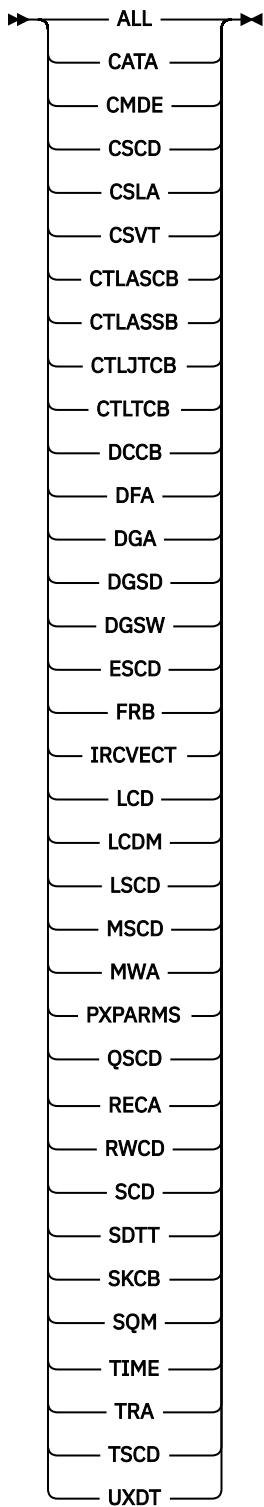

**C**

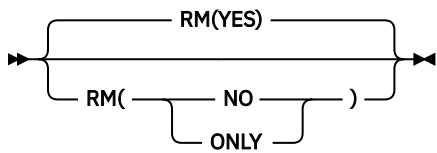

**D**

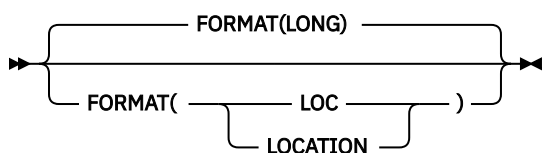

## Keywords

The following keywords are valid for the **/DIAGNOSE SNAP** command:

### ADDRESS

Captures information about a specific area of storage. The *address* value identifies the area and must specify a hexadecimal value between 0 and 7FFFFFFF.

### LENGTH

Specifies the length of the area of storage to capture. The LENGTH parameter is optional and has a default value of 8. If the LENGTH parameter is specified, the *length* value must be a numeric value from 1 to 65536.

### KEY

Specifies the key of the storage to capture. If the KEY parameter is included, the PSW key is changed to the value specified before accessing the storage. The KEY parameter is optional. Valid values for the KEY parameter are 0 and 7.

### AREA

Captures control block information for the Fast Path area specified in the *areaname* parameter. The *areaname* must be alphanumeric, no longer than 8 characters, and identify a currently defined Fast Path area. Multiple *areaname* parameters can be specified with each parameter separated by a comma or a blank.

The control blocks that can be captured for a Fast Path area are listed in the following table. Primary control blocks for an area, which are always present and available for capture, are identified by the column labeled "Primary". Optional control blocks for an area, which might be present and available for capture based on workload and other factors, are identified by the column labeled "Optional".

The **/DIAGNOSE SNAP AREA()** command is available in a DB/DC or DBCTL environment where Fast Path is defined.

Table 256. /DIAGNOSE SNAP AREA() control blocks

| Name | Block description                | Macro    | Primary | Optional |
|------|----------------------------------|----------|---------|----------|
| ALDS | DEDB Area Name List Entry        | DBFAREA  | X       |          |
| DMAC | DEDB Area Control Block          | DBFDMAC  | X       |          |
| ADSC | DEDB Area Data Set Control Block | DBFADSC  |         | X        |
| DMHR | DEDB Buffer Header (SDEP)        | DBFDMHR  |         | X        |
| DDIR | Database Directory Block         | DFSDDIR  |         | X        |
| DMCB | DEDB Master Control Block        | DBFDMCB  |         | X        |
| MRMB | DEDB Randomizing Module Block    | DBFDMRMB |         | X        |
| DMSL | Data Space Map List              | DBFDMSL  |         | X        |
| DSME | Data Space Mapping Entry         | DBFDSME  |         | X        |

Table 256. /DIAGNOSE SNAP AREA() control blocks (continued)

| Name | Block description        | Macro   | Primary | Optional |
|------|--------------------------|---------|---------|----------|
| DMAX | DMAC ERE Extension Block | DBFDMHV |         | X        |

**SHOW keyword parameters for the /DIAGNOSE SNAP AREA command**

**SHOW**

Used as a filtering mechanism to control which blocks are returned. Using the SHOW() option, a single block, list of blocks, or group of blocks identified by the keyword can be returned. The following example code shows this command option: /DIAG SNAP AREA(DEDDB01D1) SHOW(OPT).

If the SHOW() option is omitted from the /DIAGNOSE SNAP AREA() command, only the primary control blocks for the area are captured by default. The SNAP AREA() resource type supports the ALL, PRI, and OPT keywords, and all block names listed in Table 256 on page 466 as parameters to the SHOW() option. Multiple SHOW() option parameters can be specified with each parameter separated by a comma or a blank. A maximum of 16 SHOW() option parameters can be specified.

**ALL**

Captures all control blocks listed in Table 256 on page 466 that are available. Example: /DIAG SNAP AREA(DEDDB01D1) SHOW(ALL).

**PRI**

Captures the primary control blocks for the area. Primary control blocks are identified by the Primary column in Table 256 on page 466. Example: /DIAG SNAP AREA(DEDDB01D1) SHOW(PRI).

**OPT**

Captures all optional control blocks that are available. Optional control blocks are identified by the Optional column in Table 256 on page 466. Example: /DIAG SNAP AREA(DEDDB01D1) SHOW(OPT).

**blockname**

Captures the specified block by block name. Block names are defined in the Name column in Table 256 on page 466. Example: /DIAG SNAP AREA(DEDDB01D1) SHOW(ALDS).

**blockname,blockname**

Captures multiple blocks by block name. Example: /DIAG SNAP AREA(DEDDB01D1) SHOW(ALDS,DMAC).

**keyword,blockname**

Captures a group of blocks by keyword and individual blocks by block name. Example: /DIAG SNAP AREA(DEDDB01D1) SHOW(PRI,PDIR).

**BLOCK**

Captures information for a specific IMS control block. A control block name or ALL is required.

Multiple control block name parameters can be specified with each parameter separated by a comma or a blank.

Valid control block names include:

**ALL**

Captures information for all valid control blocks currently available.

**CATA**

Captures information for the Catalog Anchor control block. CATA is available only in a DB/DC or DBCTL environment.

**CMDE**

Captures information for the Commands SCD Extension control block.

**CSCD**

Captures storage information for the APPC/OTMA SMQ SCD Extension control block. CSCD is available only in a DB/DC or DCCTL environment.

**CSLA**

Captures information for the Common Service Layer Anchor control block.

**CSV**

Captures information for the Common Callable Services Vector Table control block.

**CTLASCB**

Captures information for the IMS control region Address Space Control control block.

**CTLASSB**

Captures information for the IMS control region Address Space Secondary control block.

**CTLJTCB**

Captures information for the IMS control region Job Step Task Control Block.

**CTLTCB**

Captures information for the IMS control region Primary Task Control Block.

**DCCB**

Captures information for the Data Communications control block. DCCB is available only in a DB/DC or DCCTL environment.

**DFA**

Captures information for the Definition Anchor control block.

**DGA**

Captures information for the Diagnostics Anchor control block.

**DGSD**

Captures information for the Diagnostic Data Set Structures control block.

**DGSW**

Captures information for the Diagnose Work Area Storage control block.

**ESCD**

Captures information for the Extended System Contents Directory control block. ESCD is available only in an IMS system where Fast Path is defined.

**FRB**

Captures information for the Fast Restart control block. FRB is available only in a DB/DC or DBCTL environment.

**IRCVET**

Captures information for the Log SVC Vector Table control block.

**LCD**

Captures information for the Log Control Directory (Journal) control block.

**LCDM**

Captures information for the Log Control Directory (Monitor) control block.

**LSCD**

Captures information for the APPC SCD Extension control block. LSCD is available only in a DB/DC or DCCTL environment.

**MSCD**

Captures information for the MSC SCD Extension control block. MSCD is available only in a DB/DC or DCCTL environment.

**MWA**

Captures information for the Modify Work Area control block.

**PXPARMS**

Captures information for the Modify Parameter Anchor control block.

**QSCD**

Captures information for the Queue Manager SCD Extension control block. QSCD is available only in a DB/DC or DCCTL environment.

**RECA**

Captures information for the VTAM Receive Any I/O Buffers control blocks. RECA is available only in a DB/DC or DCCTL environment.



Because of the volume of data that can be produced by capturing the VTAM Receive Any I/O Buffers, the RECA option is not included in the BLOCK(ALL) option.

**RWCD**

Captures information for the Database Recovery 2 Anchor control block. RWCD is available only in a DB/DC or DBCTL environment.

**SCD**

Captures information for the System Contents Directory control block.

**SDTT**

Captures information for the Shutdown Trace Table control block.

**SKCB**

Captures information for the Stack Control Block.

**SQM**

Captures information for the Shared Queues Master control block. SQM is available only in a shared-queues environment.

**TIME**

Captures information for the Timer Services SCD Extension control block.

**TRA**

Captures information for the Table Trace control block.

**TSCD**

Captures information for the OTMA SCD Extension control block. TSCD is available only in a DB/DC or DCCTL environment.

**UXDT**

Captures information for the User Exit Definition Table control block.

The following table shows BLOCK() resources listed by the area.

*Table 257. /DIAGNOSE SNAP BLOCK() - System control blocks*

| <b>Name</b> | <b>Block description</b>          | <b>Macro</b> |
|-------------|-----------------------------------|--------------|
| CMDE        | Commands SCD Extension            | DFSCMDE      |
| CSLA        | Common Service Layer Anchor Block | DFSCSLA      |
| CSVV        | Callable Services Vector Table    | DFSCSVT      |
| CTLASCB     | CTL Address Space Control Block   | IHAASCB      |
| CTLASSB     | CTL Address Space Secondary Block | IHAASSB      |
| CTLJTCB     | CTL Job Step Task Control Block   | IKJTCB       |
| CTLTCB      | CTL Primary Task Control Block    | IKJTCB       |
| DFA         | Definition Anchor Block           | DFSDFA       |
| DGA         | Diagnostics Anchor Block          | DFSDGA       |
| DGSD        | Diagnostic Data Set Structures    | DFSDGSWA     |
| DGSW        | Diagnose Work Area Storage        | DFSDGSWA     |
| IRCVECT     | SVC Vector Table                  | IRCVECT      |
| LCD         | Log Control Directory (Journal)   | LCDSECT      |
| LCDM        | Log Control Directory (Monitor)   | LCDSECT      |
| MWA         | Modify Work Area                  | DFSMWA       |

Table 257. /DIAGNOSE SNAP BLOCK() - System control blocks (continued)

| Name    | Block description            | Macro    |
|---------|------------------------------|----------|
| PXPARMS | Parameter Anchor Block       | PARMBLK  |
| SCD     | System Contents Directory    | ISCD     |
| SDTT    | Shutdown Trace Table         | DFSSDTT  |
| SKCB    | Stack Control Block          | DFSSKCB  |
| TIME    | Timer Services SCD Extension | DFSTIME  |
| TRA     | Table Trace Control Block    | DFSTRABK |
| UXDT    | User Exit Definition Table   | DFSUSRXD |

Table 258. /DIAGNOSE SNAP BLOCK() - DB control blocks

| Name | Block description                  | Macro   |
|------|------------------------------------|---------|
| CATA | Catalog Anchor Block               | DFS3ACH |
| ESCD | Extended System Contents Directory | DBFESCD |
| FRB  | Fast Restart Block                 | DFSFRB  |
| RWCD | Database Recovery 2 Anchor Block   | DFSRWCD |

Table 259. /DIAGNOSE SNAP BLOCK() - TM control blocks

| Name | Block description                  | Macro    |
|------|------------------------------------|----------|
| CSCD | APPC/OTMA SMQ SCD Extension        | DFSCSCD  |
| DCCB | Data Communications Control Block  | DFSDCCB  |
| LSCD | APPC SCD Extension                 | DFSLSCD  |
| MSCD | MSC SCD Extension                  | DFSMSCD  |
| QSCD | Queue Manager SCD Extension        | DFSQSCD  |
| RECA | VTAM Receive Any I/O Buffers       | BUFVTPRE |
| SQM  | Shared Queues Master Control Block | DFSSQM   |
| TSCD | OTMA SCD Extension                 | DFSTSCD  |

## DB

Captures control block information for the database specified in the *dbname* parameter. The *dbname* parameter specified must be alphanumeric, no longer than 8 characters, and identify a currently defined database. Multiple *dbname* parameters can be specified with each parameter separated by a comma or a blank.

The control blocks that can be captured for a database are listed in the following table. Primary control blocks for a database, which are always present and available for capture, are identified by the column labeled "Primary". Optional control blocks for a database, which might or might not be present and available for capture depending on workload, database type and other factors, are identified by the column labeled "Optional".

Table 260. /DIAGNOSE SNAP DB() control blocks

| Name     | Block description                  | Macro        | Primary | Optional |
|----------|------------------------------------|--------------|---------|----------|
| DDIR     | Database Directory Block           | DFSDDIR      | X       |          |
| DDIREXT  | Database Directory Block Extension | DFSDDIR      |         | X        |
| RSCX     | Resource Extension Block           | DFSRSCX      |         | X        |
| DYNALMBR | Dynamic Allocate Member            | DFSMDA       |         | X        |
| DBQLE    | Database Quiesce List Entry        | DFSDBQQ<br>L |         | X        |
| EEQE     | Error Queue Element                | DFSEEQE      |         | X        |
| RRE      | Residual Recovery Element          | DFSRRE       |         | X        |
| SDTE     | Segment Delta Block Table Entry    | DFS5FLDD     |         | X        |
| DMB      | Data Management Block              | DFSDMB       |         | X        |
| PSDB     | Physical Segment Descriptor Block  | DFSDMB       |         | X        |
| SDB      | Segment Descriptor Block           | DFSSDBM      |         | X        |
| FDB      | Field Descriptor Block             | DFSFDB       |         | X        |
| DMBCPAC  | Segment Edit/Compression Block     | DFSDMB       |         | X        |
| DMBSEC   | DMB Secondary List                 | DFSDMB       |         | X        |
| DMBDACS  | Randomizer Control Block           | DFSDMB       |         | X        |
| DMBAMPPR | Access Method Prefix Block Prefix  | DFSDMB       |         | X        |
| DMBAMP   | Access Method Prefix Block         | DFSDMB       |         | X        |
| DCBACBP  | Primary DCB/ACB Block              | DCBD         |         | X        |
| DCBACBS  | Overflow DCB/ACB Block             | DCBD         |         | X        |
| DMBXBLCK | Data Management Exit Block         | DFSDMB       |         | X        |
| DMBXARRY | Exit Array Entry Block             | DFSDMB       |         | X        |
| DMBXT    | Exit Description Block             | DFSDMB       |         | X        |
| DMCB     | DEDB Master Control Block          | DBFDMCB      |         | X        |
| BHDR     | Main Storage Database Header       | DBFBMSD<br>B |         | X        |

**SHOW keyword parameters for the /DIAGNOSE SNAP DB command**

**SHOW**

Specifies which blocks are returned. Using the SHOW() option, a single block, list of blocks, or group of blocks identified by the keyword can be returned. Example: /DIAG SNAP DB(IVPDB1) SHOW(DDIR)

If the SHOW keyword is omitted from the /DIAGNOSE SNAP DB command, only the primary control blocks for the database are captured by default.

The SNAP DB() resource type supports the ALL, OPT, and PRI keywords, and all block names listed in Table 260 on page 471 as parameters for the SHOW keyword. Multiple SHOW parameters can be specified with each parameter separated by a comma or a blank. A maximum of 16 SHOW parameters can be specified.

The effects of the SHOW option on the data captured by the **/DIAGNOSE SNAP DB** command are described in the following list:

**ALL**

Captures all control blocks listed in [Table 260 on page 471](#) that are available. Example: `/DIAG SNAP DB (IVPDB1) SHOW (ALL)`.

**OPT**

Captures all optional control blocks that are available. Optional control blocks are identified by the Optional column in [Table 260 on page 471](#). Example: `/DIAG SNAP DB (IVPDB1) SHOW (OPT)`.

**PRI**

Captures the primary control blocks for the database. Primary control blocks are identified by the Primary column in [Table 260 on page 471](#). Example: `/DIAG SNAP DB (IVPDB1) SHOW (PRI)`.

**blockname**

Captures the specified block by block name. Block names are defined in the Name column in [Table 260 on page 471](#). Example: `/DIAG SNAP DB (IVPDB1) SHOW (DDIR)`.

**blockname,blockname**

Captures multiple blocks by block name. Example: `/DIAG SNAP DB (IVPDB1) SHOW (DDIR,DMCB)`.

**keyword,blockname**

Captures a group of blocks by keyword and individual blocks by block name. Example: `/DIAG SNAP DB (IVPDB1) SHOW (PRI,DDIR)`.

**Usage notes for the /DIAGNOSE SNAP DB command**

The **/DIAGNOSE SNAP DB** command is available only in a DB/DC or DBCTL environment.

**LINE**

Captures control block information for the communication line specified in the *line#* parameter. The *line#* parameter specified must be numeric, in the range 1 - 1000, and identify a currently defined communication line. Multiple *line#* parameters can be specified with each parameter separated by a comma or a blank.

The control blocks that can be captured for a communication line are listed in the following table. Primary control blocks for a communication line, which are always present and available for capture, are identified by the column labeled "Primary". Optional control blocks for a communication line, which might be present and available for capture depending on workload and other factors, are identified by the column labeled "Optional".

*Table 261. /DIAGNOSE SNAP LINE() control blocks*

| <b>Name</b> | <b>Block description</b>      | <b>Macro</b> | <b>Primary</b> | <b>Optional</b> |
|-------------|-------------------------------|--------------|----------------|-----------------|
| EPF         | Event Control Block Prefix    | IEPF         | X              |                 |
| CULE        | Common Use List Element Block | DFSCULE      |                | X               |
| DSPWRK1     | Dispatcher Work Area          | IDSPWRK      |                | X               |
| SAP         | Save Area Prefix              | ISAP         |                | X               |
| SAVEAREA    | Save Area Set                 | REQUATE      |                | X               |
| PROLOG      | Module Prolog Information     | N/A          |                | X               |
| CLB         | Communication Line Block      | ICLI         | X              |                 |
| CTB         | Communication Terminal Block  | ICLI         |                | X               |
| CTT         | Communication Translate Table | ICLI         |                | X               |
| CRB         | Communications Restart Block  | ICLI         |                | X               |

Table 261. /DIAGNOSE SNAP LINE() control blocks (continued)

| Name        | Block description  | Macro             | Primary | Optional |
|-------------|--|-------------------|---------|----------|
| SPQB        | Subpool Queue Block  | ICLI              |         | X        |
| SPQBEXT     | Subpool Queue Extension Block                                      | ICLI              |         | X        |
| EMHB        | Expedited Message Handler Block                                    | DBFEMHB           |         | X        |
| SMB         | Scheduler Message Block  | IAPS              |         | X        |
| TIB<br>YTIB | APPC Transaction Instance Block<br>OTMA Transaction Instance Block | DFSTIB<br>DFSYTIB |         | X        |
| CNT         | Communication Name Table   | ICLI              |         | X        |
| ECNT        | Extended Communication Name Table                                  | DBFECNT           |         | X        |
| CRTCN       | Command CART & 4-Byte Console ID                                   | DFSMCSC           |         | X        |
| CCB         | Conversational Control Block                                       | ICLI              |         | X        |
| CIB         | Communication Interface Block                                      | ICLI              |         | X        |
| MSGBP       | Basic 01/03 Message Prefix   | QLOGMSGP          |         | X        |
| UOWE        | Unit of Work Table Entry   | DFSUOWE           |         | X        |
| INBUF       | Input Line Buffer  | N/A               |         | X        |
| OUTBUF      | Output Line Buffer   | N/A               |         | X        |
| RAQE        | VTAM Receive Any IO Buffer (In)                                    | BUFVTPRE          |         | X        |
| RAQERES     | VTAM Receive Any IO Buffer (Out)                                   | BUFVTPRE          |         | X        |

**SHOW keyword parameters for the /DIAGNOSE SNAP LINE command**

**SHOW**

Used as a filtering mechanism to control which blocks are returned. Using the SHOW() option, a single block, list of blocks, or group of blocks identified by the keyword can be returned.

Example: /DIAG SNAP LINE(1)

If the SHOW() option is omitted from the /DIAGNOSE SNAP LINE() command, only the primary control blocks for the communication line are captured by default. The SNAP LINE() resource type supports the ALL, PRI, and OPT keywords, and all block names listed in Table 261 on page 472 as parameters to the SHOW() option. Multiple SHOW() option parameters can be specified with each parameter separated by a comma or a blank. A maximum of 16 SHOW() option parameters can be specified.

**ALL**

Captures all control blocks listed in Table 261 on page 472 that are available. Example: /DIAG SNAP LINE(1) SHOW(ALL)

**PRI**

Captures the primary control blocks for the communication line. Primary control blocks are identified by the Primary column in Table 261 on page 472. Example: /DIAG SNAP LINE(9) SHOW(PRI)

**OPT**

Captures all optional control blocks that are available. Optional control blocks are identified by the Optional column in Table 261 on page 472. Example: /DIAG SNAP LINE(9) SHOW(OPT)

**blockname**

Captures the specified block by block name. Block names are defined in the Name column in Table 261 on page 472. Example: /DIAG SNAP LINE(1) SHOW(CLB)

**blockname,blockname**

Captures multiple blocks by block name. Example: /DIAG SNAP LINE(1) SHOW(CLB,CTT)

**keyword,blockname**

Captures a group of blocks by keyword and individual blocks by block name. Example: /DIAG SNAP LINE(1) SHOW(PRI,PDIR)

**Usage notes for the /DIAGNOSE SNAP LINE command**

The /DIAGNOSE SNAP LINE command is available in a DB/DC or DCCTL environment.

The SHOW(PROLOG) option displays information about the modules that are associated with the save areas in the chain. The module entry point is obtained from the saved register 15 value of the previous save area. If SHOW(SAVEAREA) is combined with SHOW(PROLOG), the display consists of a save area followed by the related prolog of the module that uses the save area.

The following control blocks are available only in an IMS system where Fast Path is defined.

- ECNT (Extended Communication Name Table)
- EMHB (Expedited Message Handler Block)
- SMB (Scheduler Message Block)
- TIB (APPC Transaction Instance Block)
- YTIB (OTMA Transaction Instance Block)

If the SHOW(ALL) or SHOW(OPT) option is specified in a non-Fast Path environment, these blocks are ignored. If the SHOW(ECNT), SHOW(EMHB), SHOW(SMB), SHOW(TIB), or SHOW(YTIB) option is specified in a non-Fast Path environment, a DFS154I message is issued in response.

UOWE (Unit of Work Table Entry) block is available only in an IMS system where shared queues are defined. If the SHOW(ALL) or SHOW(APP) option is specified in a non-shared-queues environment, UOWE is ignored. If the SHOW(UOWE) option is specified in a non-shared-queues environment, a DFS154I message is issued in response.

TIB (APPC Transaction Instance Block) and YTIB (OTMA Transaction Instance Block) are mutually exclusive; only one is present at any given time. For SHOW() purposes, TIB and YTIB are treated as synonyms. Specifying either TIB or YTIB displays, if available, whichever of the two blocks is present.

The SHOW(RECANY) option displays information about both RAQE (VTAM Receive Any IO Buffer (In)) and RAQERES (VTAM Receive Any IO Buffer (Out)) control blocks.

The SHOW(SA) option is a synonym for the SHOW(SAVEAREA) option.

**LINK**

Captures control block information for the logical link specified in the *link#* parameter. The *link#* parameter specified must be numeric, in the range 1 - 936, and identify a currently defined logical link. Multiple *link#* parameters can be specified with each parameter separated by a comma or a blank.

The control blocks that can be captured for a logical link are listed in the following table. Primary control blocks for a logical link, which are always present and available for capture, are identified by the column labeled "Primary". Optional control blocks for a logical link, which might be present and available for capture depending on workload and other factors, are identified by the column labeled "Optional".

Table 262. /DIAGNOSE SNAP LINK() control blocks

| Name | Block description             | Macro   | Primary | Optional |
|------|-------------------------------|---------|---------|----------|
| EPF  | Event Control Block Prefix    | IEPF    | X       |          |
| CULE | Common Use List Element Block | DFSCULE |         | X        |

Table 262. /DIAGNOSE SNAP LINK() control blocks (continued)

| Name     | Block description                 | Macro    | Primary | Optional |
|----------|-----------------------------------|----------|---------|----------|
| DSPWRK1  | Dispatcher Work Area              | IDSPWRK  |         | X        |
| SAP      | Save Area Prefix                  | ISAP     |         | X        |
| SAVEAREA | Save Area Set                     | REQUATE  |         | X        |
| PROLOG   | Module Prolog Information         | N/A      |         | X        |
| LLB      | Link Line Block                   | ICLI     | X       |          |
| LTB      | Link Terminal Block               | ICLI     |         | X        |
| CTT      | Communication Translate Table     | ICLI     |         | X        |
| CRB      | Communications Restart Block      | ICLI     |         | X        |
| SPQB     | Subpool Queue Block               | ICLI     |         | X        |
| SPQBEXT  | Subpool Queue Extension Block     | ICLI     |         | X        |
| EMHB     | Expedited Message Handler Block   | DBFEMHB  |         | X        |
| SMB      | Scheduler Message Block           | IAPS     |         | X        |
| TIB      | APPC Transaction Instance Block   | DFSTIB   |         |          |
| YTIB     | OTMA Transaction Instance Block   | DFSYTIB  |         | X        |
| LNB      | Link Name Block                   | ICLI     |         | X        |
| ECNT     | Extended Communication Name Table | DBFECNT  |         | X        |
| CRTCN    | Command CART & 4-Byte Console ID  | DFSMCSC  |         | X        |
| CCB      | Conversational Control Block      | ICLI     |         | X        |
| CIB      | Communication Interface Block     | ICLI     |         | X        |
| MSGBP    | Basic 01/03 Message Prefix        | QLOGMSGP |         | X        |
| UOWE     | Unit of Work Table Entry          | DFSUOWE  |         | X        |
| INBUF    | Input Line Buffer                 | N/A      |         | X        |
| OUTBUF   | Output Line Buffer                | N/A      |         | X        |
| LCB      | Link Control Block                | LCB      |         | X        |
| LXB      | Link Extension Block              | LXB      |         | X        |

**SHOW keyword parameters for the /DIAGNOSE SNAP LINK command**

**SHOW**

Used as a filtering mechanism to control which blocks are returned. Using the SHOW() option, a single block, list of blocks, or group of blocks identified by the keyword can be returned. The following example code shows this command option: /DIAG SNAP LINK(9)

If the SHOW() option is omitted from the /DIAGNOSE SNAP LINK() command, only the primary control blocks for the logical line are captured by default. The SNAP LINK() resource type supports the ALL, PRI, and OPT keywords, and all block names that are listed in [Table 262 on page 474](#) as parameters to the SHOW() option. Multiple SHOW() option parameters can be specified with each parameter separated by a comma or a blank. A maximum of 16 SHOW() option parameters can be specified.

**ALL**

Captures all control blocks listed in [Table 262 on page 474](#) that are available. Example: /DIAG SNAP LINK(9) SHOW(ALL)

**PRI**

Captures the primary control blocks for the logical line. Primary control blocks are identified by the Primary column in [Table 262 on page 474](#). Example: /DIAG SNAP LINK(9) SHOW(PRI)

**OPT**

Captures all optional control blocks that are available. Optional control blocks are identified by the Optional column in [Table 262 on page 474](#). Example: /DIAG SNAP LINE(9) SHOW(OPT)

**blockname**

Captures the specified block by block name. Block names are defined in the Name column in [Table 262 on page 474](#). Example: /DIAG SNAP LINK(9) SHOW(CLB)

**blockname,blockname**

Captures multiple blocks by block name. Example: /DIAG SNAP LINK(9) SHOW(LLB,CTT)

**keyword,blockname**

Captures a group of blocks by keyword and individual blocks by block name. Example: /DIAG SNAP LINK(9) SHOW(PRI, PDIR)

**Usage notes for the /DIAGNOSE SNAP LINK command**

The **/DIAGNOSE SNAP LINK()** command is available only in a DB/DC or DCCTL environment.

The SHOW(PROLOG) option displays information about the modules that are associated with the save areas in the chain. The module entry point is obtained from the saved register 15 value of the previous save area. If SHOW(SAVEAREA) is combined with SHOW(PROLOG), the display consists of a save area followed by the related prolog of the module that uses the save area.

The following control blocks are available only in an IMS system where Fast Path is defined.

- ECNT (Extended Communication Name Table)
- EMHB (Expedited Message Handler Block)
- SMB (Scheduler Message Block)
- TIB (APPC Transaction Instance Block)
- YTIB (OTMA Transaction Instance Block)

If the SHOW(ALL) or SHOW(OPT) option is specified in a non-Fast Path environment, these blocks are ignored. If the SHOW(ECNT), SHOW(EMHB), SHOW(SMB), SHOW(TIB), or SHOW(YTIB) option is specified in a non-Fast Path environment, a DFS154I message is issued in response.

UOWE (Unit of Work Table Entry) block is available only in an IMS system where shared queues are defined. If the SHOW(ALL) or SHOW(APP) option is specified in a non-shared-queues environment, UOWE is ignored. If the SHOW(UOWE) option is specified in a non-shared-queues environment, a DFS154I message is issued in response.

TIB (APPC Transaction Instance Block) and YTIB (OTMA Transaction Instance Block) are mutually exclusive; only one is present at any given time. For SHOW() purposes, TIB and YTIB are treated as synonyms. Specifying either TIB or YTIB displays, if available, whichever of the two blocks is present.

The SHOW(SA) option is a synonym for the SHOW(SAVEAREA) option.

**LTERM**

Captures control block information for the logical terminal specified in the *ltermname* parameter. The *ltermname* parameter specified must be alphanumeric, no longer than 8 characters, and identify a currently defined logical terminal. Multiple *ltermname* parameters can be specified with each parameter separated by a comma or a blank.

The control blocks that can be captured for logical terminals are listed in the following table. Primary control blocks for a logical terminal, which are always present and available for capture, are identified by the column labeled "Primary". Optional control blocks for a logical terminal, which might or might



not be present and available for capture depending on workload and other factors, are identified by the column labeled "Optional".

Table 263. /DIAGNOSE SNAP LTERM() control blocks

| Name        | Block description  | Macro             | Primary        | Optional |
|-------------|--|-------------------|----------------|----------|
| CNT         | Communication Name Table (Target)                                  | ICLI              | X <sup>1</sup> |          |
| RCNT        | Remote Communication Name Table                                    | RCNT              | X <sup>2</sup> |          |
| LNB         | Link Name Block  | LNB               | X <sup>2</sup> |          |
| EPF         | Event Control Block Prefix   | IEPF              |                | X        |
| CULE        | Common Use List Element Block                                      | DFSCULE           |                | X        |
| DSPWRK1     | Dispatcher Work Area   | IDSPWRK           |                | X        |
| SAP         | Save Area Prefix   | ISAP              |                | X        |
| SAVEAREA    | Save Area Set  | REQUATE           |                | X        |
| PROLOG      | Module Prolog Information  | N/A               |                | X        |
| CLB         | Communication Line Block   | ICLI              |                | X        |
| CTB         | Communication Terminal Block                                       | ICLI              |                | X        |
| CTT         | Communication Translate Table                                      | ICLI              |                | X        |
| CRB         | Communications Restart Block                                       | ICLI              |                | X        |
| SPQB        | Subpool Queue Block  | ICLI              |                | X        |
| SPQBEXT     | Subpool Queue Extension Block                                      | ICLI              |                | X        |
| EMHB        | Expedited Message Handler Block                                    | DBFEMHB           |                | X        |
| SMB         | Scheduler Message Block  | IAPS              |                | X        |
| TIB<br>YTIB | APPC Transaction Instance Block<br>OTMA Transaction Instance Block | DFSTIB<br>DFSYTIB |                | X        |
| CNT         | Communication Name Table   | ICLI              |                | X        |
| ECNT        | Extended Communication Name Table                                  | DBFECNT           |                | X        |
| CRTCN       | Command CART & 4-Byte Console ID                                   | DFSMCSC           |                | X        |
| CCB         | Conversational Control Block                                       | ICLI              |                | X        |
| CIB         | Communication Interface Block                                      | ICLI              |                | X        |
| MSGBP       | Basic 01/03 Message Prefix   | QLOGMSGP          |                | X        |
| UOWE        | Unit of Work Table Entry   | DFSUOWE           |                | X        |
| INBUF       | Input Line Buffer  | N/A               |                | X        |
| OUTBUF      | Output Line Buffer   | N/A               |                | X        |
| RAQE        | VTAM Receive Any IO Buffer (In)                                    | BUFVTPRE          |                | X        |
| RAQERES     | VTAM Receive Any IO Buffer (Out)                                   | BUFVTPRE          |                | X        |

<sup>1</sup> Primary blocks for a local logical terminal

<sup>2</sup> Primary blocks for a remote logical terminal

## ***SHOW keyword parameters for the /DIAGNOSE SNAP LTERM command***

### **SHOW**

Specifies which blocks are returned. If the SHOW keyword is omitted from the **/DIAGNOSE SNAP LTERM** command, only the primary control blocks for the logical terminal are captured by default. The SNAP LTERM() resource type supports the ALL, DEF (or DEFAULT), OPT, PRI, and TAR (or TARGET) keywords, and all block names that are listed in [Table 263 on page 477](#) as parameters for the SHOW keyword. Multiple SHOW parameters can be specified with each parameter separated by a comma or a blank. A maximum of 32 SHOW parameters can be specified.

The effects of the SHOW option on the data that is captured by the **/DIAGNOSE SNAP LTERM** command are described in the following list:

#### **ALL**

Captures all control blocks listed in [Table 263 on page 477](#) that are available. Example: `/DIAG SNAP LTERM(MTRL) SHOW(ALL)`.

#### **DEF**

Captures information about default blocks for the current logical terminal. DEF, or DEFAULT, is equivalent to the PRI keyword or without any SHOW parameter. Example: `/DIAGNOSE SNAP LTERM(MTRL) SHOW(DEF)`.

#### **OPT**

Captures all optional control blocks that are available. Optional control blocks are identified by the Optional column in [Table 263 on page 477](#). Example: `/DIAG SNAP LTERM(MTRL) SHOW(OPT)`.

#### **PRI**

Captures the primary control blocks for the logical terminal. Primary control blocks are identified by the Primary column in [Table 263 on page 477](#). Example: `/DIAG SNAP LTERM(MTRL) SHOW(PRI)`.

#### **TARGET**

Captures the target CNT (Communication Name Table) for a local logical terminal (LTERM). TARGET can be abbreviated as TAR.

If the SHOW(TARGET) option is specified and the only resource specified is a remote logical terminal, a DFS2859I informational message is issued with the following reason text: NO VALID BLOCKS SPECIFIED FOR LTERM(*Ltermname*). If other SHOW() options are included that are applicable to a remote logical terminal, those blocks are displayed, and the TARGET option is ignored.

If the SHOW(TARGET) option is specified and both local and remote logical terminal resources are specified, a DFS2859I message is issued for the remote logical terminal.

Example: `/DIAGNOSE SNAP LTERM(MTRL) SHOW(TAR)`.

#### ***blockname***

Captures the specified block by block name. Block names are defined in the Name column in [Table 263 on page 477](#). Example: `/DIAG SNAP LTERM(MTRL) SHOW(CLB)`.

#### ***blockname,blockname***

Captures multiple blocks by block name. Example: `/DIAG SNAP LTERM(MTRL) SHOW(CLB,CTB)`.

#### ***keyword,blockname***

Captures a group of blocks by keyword and individual blocks by block name. Example: `/DIAG SNAP LTERM(MTRL) SHOW(PRI,CTB)`.

### ***Usage notes for the /DIAGNOSE SNAP LTERM command***

The **/DIAGNOSE SNAP LTERM** command is available in a DB/DC or DCCTL environment.

The SHOW(PROLOG) option displays information about the modules that are associated with the save areas in the chain. The module entry point is obtained from the saved register 15 value of the previous

save area. If SHOW(SAVEAREA) is combined with SHOW(PROLOG), the display consists of a save area followed by the related prolog of the module that uses the save area.

The following control blocks are available only in an IMS system where Fast Path is defined.

- ECNT (Extended Communication Name Table)
- EMHB (Expedited Message Handler Block)
- SMB (Scheduler Message Block)
- TIB (APPC Transaction Instance Block)
- YTIB (OTMA Transaction Instance Block)

If the SHOW(ALL) or SHOW(OPT) option is specified in a non-Fast Path environment, these blocks are ignored. If the SHOW(ECNT), SHOW(EMHB), SHOW(SMB), SHOW(TIB), or SHOW(YTIB) option is specified in a non-Fast Path environment, a DFS154I message is issued in response.

UOWE (Unit of Work Table Entry) block is available only in an IMS system where shared queues are defined. If the SHOW(ALL) or SHOW(APP) option is specified in a non-shared-queues environment, UOWE is ignored. If the SHOW(UOWE) option is specified in a non-shared-queues environment, a DFS154I message is issued in response.

If the SHOW(RCNT), SHOW(LNB), or SHOW(RCNT,LNB) option is specified and the only resource specified is a local logical terminal, a DFS2859I informational message is issued. If other SHOW() options are included that are applicable to a local logical terminal, those blocks are displayed, and the RCNT or LNB option is ignored.

If the SHOW(RCNT), SHOW(LNB), or SHOW(RCNT,LNB) option is specified and both local and remote logical terminal resources are specified, a DFS2859I message is issued for the local logical terminal.

TIB (APPC Transaction Instance Block) and YTIB (OTMA Transaction Instance Block) are mutually exclusive; only one is present at any given time. For SHOW() purposes, TIB and YTIB are treated as synonyms. Specifying either TIB or YTIB displays, if available, whichever of the two blocks is present.

The SHOW(RECANY) option displays information about both RAQE (VTAM Receive Any IO Buffer (In)) and RAQERES (VTAM Receive Any IO Buffer (Out)) control blocks.

The SHOW(SA) option is a synonym for the SHOW(SAVEAREA) option.

## MODULE

Returns the entry point address and captures in-storage prolog information about the IMS module specified in the *modname* parameter. The standard IMS module in-storage prolog information contains the module name, product level, assembly date and time, last APAR ID, module maintenance level, BPE version, and release (for BPE-based modules), and copyright statement.

**Note:** The name of the IMS module that appears in the in-storage prolog information might not be the same as the loaded module name if binder options were used to declare a different name for the loaded module.

MODULE(*modname*) enables IBM Software Support representatives to see the maintenance level of the installed software.

## MSNAME

Captures control block information for the MSNAME specified in the *msname* parameter. The *msname* parameter specified must be alphanumeric, no longer than 8 characters, and identify a currently defined MSNAME. Multiple *msname* parameters can be specified with each parameter separated by a comma or a blank.

The control blocks that can be captured for MSNAMEs are listed in the following table. Primary control blocks for an MSNAME, which are always present and available for capture, are identified by the column labeled "Primary". Optional control blocks for an MSNAME, which might or might not be present and available for capture depending on workload and other factors, are identified by the column labeled "Optional".

Table 264. /DIAGNOSE SNAP MSNAME() control blocks

| Name     | Block description                 | Macro    | Primary | Optional |
|----------|-----------------------------------|----------|---------|----------|
| LNB      | Link Name Block (Target)          | LNB      | X       |          |
| EPF      | Event Control Block Prefix        | IEPF     |         | X        |
| CULE     | Common Use List Element Block     | DFSCULE  |         | X        |
| DSPWRK1  | Dispatcher Work Area              | IDSPWRK  |         | X        |
| SAP      | Save Area Prefix                  | ISAP     |         | X        |
| SAVEAREA | Save Area Set                     | REQUATE  |         | X        |
| PROLOG   | Module Prolog Information         | N/A      |         | X        |
| LLB      | Link Line Block                   | ICLI     |         | X        |
| LTB      | Link Terminal Block               | ICLI     |         | X        |
| CTT      | Communication Translate Table     | ICLI     |         | X        |
| CRB      | Communications Restart Block      | ICLI     |         | X        |
| SPQB     | Subpool Queue Block               | ICLI     |         | X        |
| SPQBEXT  | Subpool Queue Extension Block     | ICLI     |         | X        |
| EMHB     | Expedited Message Handler Block   | DBFEMHB  |         | X        |
| SMB      | Scheduler Message Block           | IAPS     |         | X        |
| TIB      | APPC Transaction Instance Block   | DFSTIB   |         |          |
| YTIB     | OTMA Transaction Instance Block   | DFSYTIB  |         | X        |
| LNB      | Link Name Block                   | ICLI     |         | X        |
| ECNT     | Extended Communication Name Table | DBFECNT  |         | X        |
| CRTCN    | Command CART & 4-Byte Console ID  | DFSMCSC  |         | X        |
| CCB      | Conversational Control Block      | ICLI     |         | X        |
| CIB      | Communication Interface Block     | ICLI     |         | X        |
| MSGBP    | Basic 01/03 Message Prefix        | QLOGMSGP |         | X        |
| UOWE     | Unit of Work Table Entry          | DFSUOWE  |         | X        |
| INBUF    | Input link buffer                 | N/A      |         | X        |
| OUTBUF   | Output link buffer                | N/A      |         | X        |
| LCB      | Link Control Block                | LCB      |         | X        |
| LXB      | Link Extension Block              | LXB      |         | X        |

**SHOW keyword parameters for the /DIAGNOSE SNAP MSNAME command**

**SHOW**

Specifies which blocks are to be returned. If the SHOW keyword is omitted from the /DIAGNOSE SNAP NODE command, only the primary control blocks for the MSNAME are captured by default. The SNAP MSNAME resource type supports the ALL, PRI, OPT, and TAR (or TARGET) keywords, and all block names that are listed in [Table 264 on page 480](#) as parameters for the SHOW

keyword. Multiple SHOW parameters can be specified with each parameter separated by a comma or a blank. A maximum of 32 SHOW parameters can be specified.

The effects of the SHOW option on the data that is captured by the **/DIAGNOSE SNAP MSNAME** command are described in the following list:

**ALL**

Captures all control blocks listed in [Table 264 on page 480](#) that are available. Example: `/DIAGNOSE SNAP MSNAME(MSN1) SHOW(ALL)`.

**OPT**

Captures all optional control blocks that are available. Optional control blocks are identified by the Optional column in [Table 264 on page 480](#). Example: `/DIAGNOSE SNAP MSNAME(MSN1) SHOW(OPT)`.

**PRI**

Captures the primary control blocks for the MSNAME. Primary control blocks are identified by the Primary column in [Table 264 on page 480](#). Example: `/DIAGNOSE SNAP MSNAME(MSN1) SHOW(PRI)`.

**TARGET**

Captures the target LNB (Link Name Block) for the MSNAME. TARGET can be abbreviated as TAR. Example: `/DIAGNOSE SNAP MSNAME(MTR1) SHOW(TAR)`.

***blockname***

Captures the specified block by block name. Block names are defined in the Name column in [Table 264 on page 480](#). Example: `/DIAGNOSE SNAP MSNAME(MSN1) SHOW(CLB)`.

***blockname,blockname***

Captures multiple blocks by block name. Example: `/DIAGNOSE SNAP MSNAME(MSN1) SHOW(CLB,CTB)`.

***keyword,blockname***

Captures a group of blocks by keyword and individual blocks by block name. Example: `/DIAGNOSE SNAP MSNAME(MSN1) SHOW(PRI,CTB)`.

***Usage notes for the /DIAGNOSE SNAP MSNAME command***

The **/DIAGNOSE SNAP MSNAME** command is available only in a DB/DC or DCCTL environment.

The following control blocks are available only in an IMS system where Fast Path is defined.

- ECNT (Extended Communication Name Table)
- EMHB (Expedited Message Handler Block)
- SMB (Scheduler Message Block)
- TIB (APPC Transaction Instance Block)
- YTIB (OTMA Transaction Instance Block)

If the SHOW(ALL) or SHOW(OPT) option is specified in a non-Fast Path environment, these blocks are ignored. If the SHOW(ECNT), SHOW(EMHB), SHOW(SMB), SHOW(TIB), or SHOW(YTIB) option is specified in a non-Fast Path environment, a DFS154I message is issued in response.

UOWE (Unit of Work Table Entry) block is available only in an IMS system where shared queues are defined. If the SHOW(ALL) or SHOW(APP) option is specified in a non-shared-queues environment, UOWE is ignored. If the SHOW(UOWE) option is specified in a non-shared-queues environment, a DFS154I message is issued in response.

TIB (APPC Transaction Instance Block) and YTIB (OTMA Transaction Instance Block) are mutually exclusive; only one is present at any given time. For SHOW() purposes, TIB and YTIB are treated as synonyms. Specifying either TIB or YTIB displays, if available, whichever of the two blocks is present.

The SHOW(PROLOG) option displays information about the modules that are associated with the save areas in the chain. The module entry point is obtained from the saved register 15 value of the previous save area. If SHOW(SAVEAREA) is combined with SHOW(PROLOG), the display consists of a save area followed by the related prolog of the module that uses the save area.

The SHOW(SA) option is a synonym for the SHOW(SAVEAREA) option.

## NODE

Captures control block information for the node name specified in the *nodename* parameter. The *nodename* parameter specified must be alphanumeric, no longer than 8 characters, and identify a currently defined node name. Multiple *nodename* parameters can be specified with each parameter separated by a comma or a blank.

The control blocks that can be captured for node names are listed in Table 265 on page 482. Primary control blocks for a node name, which are always present and available for capture, are identified by the column labeled "Primary". Optional control blocks for a node name, which might or might not be present and available for capture depending on workload and other factors, are identified by the column labeled "Optional".

Table 265. /DIAGNOSE SNAP NODE() control blocks

| Name     | Block description                 | Macro    | Primary | Optional |
|----------|-----------------------------------|----------|---------|----------|
| EPF      | Event Control Block Prefix        | IEPF     | X       |          |
| CULE     | Common Use List Element Block     | DFSCULE  |         | X        |
| DSPWRK1  | Dispatcher Work Area              | IDSPWRK  |         | X        |
| SAP      | Save Area Prefix                  | ISAP     |         | X        |
| SAVEAREA | Save Area Set                     | REQUATE  |         | X        |
| PROLOG   | Module Prolog Information         | N/A      |         | X        |
| CLB      | Communication Line Block          | ICLI     | X       |          |
| CTB      | Communication Terminal Block      | ICLI     |         | X        |
| CTT      | Communication Translate Table     | ICLI     |         | X        |
| CRB      | Communications Restart Block      | ICLI     |         | X        |
| SPQB     | Subpool Queue Block               | ICLI     |         | X        |
| SPQBEXT  | Subpool Queue Extension Block     | ICLI     |         | X        |
| EMHB     | Expedited Message Handler Block   | DBFEMHB  |         | X        |
| SMB      | Scheduler Message Block           | IAPS     |         | X        |
| TIB      | APPC Transaction Instance Block   | DFSTIB   |         |          |
| YTIB     | OTMA Transaction Instance Block   | DFSYTIB  |         | X        |
| CNT      | Communication Name Table          | ICLI     |         | X        |
| ECNT     | Extended Communication Name Table | DBFECNT  |         | X        |
| CRTCN    | Command CART & 4-Byte Console ID  | DFSMCSC  |         | X        |
| CCB      | Conversational Control Block      | ICLI     |         | X        |
| CIB      | Communication Interface Block     | ICLI     |         | X        |
| MSGBP    | Basic 01/03 Message Prefix        | QLOGMSGP |         | X        |
| UOWE     | Unit of Work Table Entry          | DFSUOWE  |         | X        |
| INBUF    | Input Line Buffer                 | N/A      |         | X        |
| OUTBUF   | Output Line Buffer                | N/A      |         | X        |

Table 265. /DIAGNOSE SNAP NODE() control blocks (continued)

| Name    | Block description                | Macro    | Primary | Optional |
|---------|----------------------------------|----------|---------|----------|
| RAQE    | VTAM Receive Any IO Buffer (In)  | BUFVTPRE |         | X        |
| RAQERES | VTAM Receive Any IO Buffer (Out) | BUFVTPRE |         | X        |

**SHOW keyword parameters for the /DIAGNOSE SNAP NODE command**

**SHOW**

Specifies which blocks are returned. If the SHOW keyword is omitted from the /DIAGNOSE SNAP NODE command, only the primary control blocks for the node name are captured by default. The SNAP NODE resource type supports the ALL, OPT, and PRI keywords, and all block names that are listed in Table 265 on page 482 as parameters for the SHOW keyword. Multiple SHOW parameters can be specified with each parameter separated by a comma or a blank. A maximum of 32 SHOW parameters can be specified.

The effects of the SHOW option on the data that is captured by the /DIAGNOSE SNAP NODE command are described in the following list:

**ALL**

Captures all control blocks listed in Table 265 on page 482 that are available. Example: /DIAGNOSE SNAP NODE(L3270A) SHOW(ALL).

**OPT**

Captures all optional control blocks that are available. Optional control blocks are identified by the Optional column in Table 265 on page 482. Example: /DIAGNOSE SNAP NODE(L3270A) SHOW(OPT).

**PRI**

Captures the primary control blocks for the node. Primary control blocks are identified by the Primary column in Table 265 on page 482. Example: /DIAGNOSE SNAP NODE(L3270A) SHOW(PRI).

**blockname**

Captures the specified block by block name. Block names are defined in the Name column in Table 265 on page 482. Example: /DIAGNOSE SNAP NODE(L3270A) SHOW(CLB).

**blockname,blockname**

Captures multiple blocks by block name. Example: /DIAGNOSE SNAP NODE(L3270A,L3270B) SHOW(CLB,CTB).

**keyword,blockname**

Captures a group of blocks by keyword and individual blocks by block name. Example: /DIAG SNAP LTERM(MTRL) SHOW(PRI,CTB).

**Usage notes for the /DIAGNOSE SNAP NODE command**

The /DIAGNOSE SNAP NODE command is available only in a DB/DC or DCCTL environment.

The following control blocks are available only in an IMS system where Fast Path is defined.

- ECNT (Extended Communication Name Table)
- EMHB (Expedited Message Handler Block)
- SMB (Scheduler Message Block)
- TIB (APPC Transaction Instance Block)
- YTIB (OTMA Transaction Instance Block)

If the SHOW(ALL) or SHOW(OPT) option is specified in a non-Fast Path environment, these blocks are ignored. If the SHOW(ECNT), SHOW(EMHB), SHOW(SMB), SHOW(TIB), or SHOW(YTIB) option is specified in a non-Fast Path environment, a DFS154I message is issued in response.

UOWE (Unit of Work Table Entry) block is available only in an IMS system where shared queues are defined. If the SHOW(ALL) or SHOW(APP) option is specified in a non-shared-queues environment,

UOWE is ignored. If the SHOW(UOWE) option is specified in a non-shared-queues environment, a DFS154I message is issued in response.

TIB (APPC Transaction Instance Block) and YTIB (OTMA Transaction Instance Block) are mutually exclusive; only one is present at any given time. For SHOW() purposes, TIB and YTIB are treated as synonyms. Specifying either TIB or YTIB displays, if available, whichever of the two blocks is present.

The SHOW(PROLOG) option displays information about the modules that are associated with the save areas in the chain. The module entry point is obtained from the saved register 15 value of the previous save area. If SHOW(SAVEAREA) is combined with SHOW(PROLOG), the display consists of a save area followed by the related prolog of the module that uses the save area.

The SHOW(RECANY) option displays information about both RAQE (VTAM Receive Any IO Buffer (In)) and RAQERES (VTAM Receive Any IO Buffer (Out)) control blocks.

The SHOW(SA) option is a synonym for the SHOW(SAVEAREA) option.

## **OPTION**

Specifies the destination for the resource information captured by the SNAP function. The OPTION parameter is optional.

### **DISPLAY**

SNAP output is formatted and displayed on the issuing LTERM. DISPLAY is the default.

You can specify the following keywords with the DISPLAY option:

#### **LIMIT**

Specifies a limit for the number of lines of formatted SNAP data to display in response to the command. LIMIT is a subparameter of the DISPLAY option. The LIMIT parameter is optional and has a default value of 1999. The *linecount* parameter must be numeric and in the range 1 - 9999.

#### **FORMAT**

Specifies the format of the output to be produced. The default is FORMAT(LONG). Valid values for the FORMAT() parameter are:

#### **LOC**

#### **LOCATION**

Only the block name, description, and location are displayed.

#### **LONG**

The complete display is produced, which includes the block name, description, location, and a dump of the complete storage area for the block in both hexadecimal and character format.

## **OLDS**

SNAP data is written to the OLDS.

## **SYSOUT**

SNAP data is queued to the diagnostic asynchronous work element (AWE) service and written to a SYSOUT data set.

You can specify the following keywords with the SYSOUT option:

### **CLASS**

Specifies an output class for the SYSOUT data set. The attributes of each output class are installation-specific and defined during JES initialization. The *sysout\_class* parameter must be a single alphanumeric character A - Z or 0 - 9. Any defined, valid JES output class can be specified. The characteristics of the SYSOUT data set are: DSORG=PS, RECFM=FB, LRECL=80, BLKSIZE=4080. The CLASS parameter is optional and defaults to the default SYSOUT class assigned to the IMS control region.

### **LIMIT**

Specifies a limit for the number of lines of formatted SNAP data to process.

The LIMIT parameter is optional and has a default value of 19999. If specified, the *linecount* parameter must be numeric and in the range 1 - 99999.



## FORMAT

Specifies the format of the output to be produced. The default is FORMAT(LONG). Valid values for the FORMAT() parameter are:

### LOC

#### LOCATION

Only the block name, description, and location are displayed.

### LONG

The complete display is produced, which includes the block name, description, location, and a dump of the complete storage area for the block in both hexadecimal and character format.

## TRACE

If TRACE is specified, SNAP data is written to the trace data sets.

**Important:** If you do not issue the **/TRACE SET ON TABLE DIAG OPTION LOG** command before issuing the **/DIAGNOSE** command with the TRACE option, the **/DIAGNOSE** command automatically turns on the DIAG trace tables, writes the output to the trace tables, and then turns off the DIAG trace tables. One disadvantage of this method is that the output from only one **/DIAGNOSE** command can be written to the trace data sets; that is, each new command overwrites the data from the last command. To capture data from a series of **/DIAGNOSE** commands in a trace data set, issue the commands in this order:

1. **/TRACE SET ON TABLE DIAG OPTION LOG** command
2. **/DIAGNOSE** commands
3. **/TRACE SET OFF TABLE DIAG** command

## PGM

Captures control block information for the program specified in the *pgmname* parameter. The *pgmname* parameter specified must be alphanumeric, no longer than eight characters, and identify a currently defined program. Multiple *pgmname* parameters can be specified with each parameter separated by a comma or a blank.

The control blocks that can be captured for a program are listed in the following table. Primary control blocks for a logical line, which are always present and available for capture, are identified by the column labeled "Primary". Optional control blocks for a logical link, which might be present and available for capture based on workload and other factors, are identified by the column labeled "Optional".

Table 266. /DIAGNOSE SNAP PGM() control blocks

| Name    | Block description                             | Macro   | Primary | Optional | Work | No Work |
|---------|---|---------|---------|----------|------|---------|
| PDIR    | Program Directory Block                       | DFSPDIR | X       |          |      | X       |
| RSCX    | Resource Extension Block                      | DFSRSCX |         | X        |      | X       |
| INTLIST | Intent List                                   | INTLIST |         | X        |      | X       |
| PSB     | Program Specification Block                   | DFSPSB  |         | X        |      | X       |
| PST     | Partition Specification Table                 | IPST    |         | X        |      | X       |
| CNT     | Communication Name Table                      | ICLI    |         | X        |      | X       |
| SMB     | Scheduler Message Block                       | IAPS    |         | X        |      | X       |
| DMBL    | Data management Block List                    | DFSDMBL |         | X        |      | X       |
| XPCB    | Program Communication Block Index Maintenance | DFSPCBS |         | X        |      | X       |
| PCB     | Program Communication Block                   | DFSPCBS |         | X        |      | X       |

Table 266. /DIAGNOSE SNAP PGM() control blocks (continued)

| Name   | Block description                     | Macro    | Primary | Optional | Work | No Work |
|--------|---------------------------------------|----------|---------|----------|------|---------|
| PCBX   | Program Communication Extension Block | DFSPCBS  |         | X        |      | X       |
| EPCB   | Program Communication Block Extension | DBFEPCB  |         | X        |      | X       |
| MSG6P  | Message Prefix (LU62)                 | DFS62PRE |         | X        |      | X       |
| MSGOP  | Message Prefix (OTMA)                 | DFSYPRE  |         |          |      |         |
| PSBPRM | User Parameter List Block             | IDLI     |         | X        |      | X       |
| WKCDSD | Data Capture Segment Work Area        | N/A      |         | X        | X    |         |
| WKNDX  | Index Maintenance Work Area           | N/A      |         | X        | X    |         |
| WKXIO  | Index I/O Work Area                   | N/A      |         | X        | X    |         |
| WKSEG  | Segment Work Area                     | N/A      |         | X        | X    |         |
| WKIOA  | I/O Work Area                         | N/A      |         | X        | X    |         |
| WKSSA  | Segment Search Argument Work Area     | N/A      |         | X        | X    |         |
| WKIFP  | Fast Path Control Block Work Area     | N/A      |         | X        | X    |         |

**SHOW keyword parameters for the /DIAGNOSE SNAP PGM command**

**SHOW**

Specifies which blocks are returned. Using the SHOW() option, a single block, list of blocks, or group of blocks identified by the keyword can be returned. Example: /DIAG SNAP PGM(APOL1)

If the SHOW() option is omitted from the /DIAGNOSE SNAP PGM() command, only the primary control blocks for the program are captured by default. The SNAP PGM() resource type supports the ALL, OPT, PRI, WORK, and NOWORK keywords, and all block names that are listed in [Table 266 on page 485](#) as parameters to the SHOW() option. Multiple SHOW() option parameters can be specified with each parameter separated by a comma or a blank. A maximum of 32 SHOW() option parameters can be specified.

**ALL**

Captures all control blocks listed in [Table 266 on page 485](#) that are available. Example: /DIAG SNAP PGM(APOL1) SHOW(ALL)

**PRI**

Captures the primary control blocks for the program. Primary control blocks are identified by the Primary column in [Table 266 on page 485](#). Example: /DIAG SNAP PGM(APOL1) SHOW(PRI)

**OPT**

Captures all optional control blocks that are available. Optional control blocks are identified by the Optional column in [Table 266 on page 485](#). Example: /DIAG SNAP PGM(APOL1) SHOW(OPT)

**blockname**

Captures the specified block by block name. Block names are defined in the Name column in [Table 266 on page 485](#). Example: /DIAG SNAP PGM(APOL1) SHOW(PDIR)

**blockname,blockname**

Captures multiple blocks by block name. Example: /DIAG SNAP PGM(APOL1)  
SHOW(PDIR,PSB)

**keyword,blockname**

Captures a group of blocks by keyword and individual blocks by block name. Example: /DIAG SNAP PGM(APOL1) SHOW(PRI,PDIR)

**WORK**

Captures all working storage blocks that are available. Working storage blocks are identified by the Work column in [Table 266 on page 485](#). Example: /DIAG SNAP PGM(APOL1)  
SHOW(WORK)

**NOWORK**

Captures all non-work control blocks that are available. Non-work control blocks are identified by the No Work column in [Table 266 on page 485](#). Example: /DIAG SNAP PGM(APOL1)  
SHOW(NOWORK)

**Usage notes for the /DIAGNOSE SNAP PGM command**

EPCB (Program Communication Block Extension) is available only in an IMS system where Fast Path is defined. If the SHOW(ALL) or SHOW(OPT) option is specified in a non-FP environment, the EPCB is ignored. If the SHOW(EPCB) option is specified in a non-FP environment, a DFS154I error message is issued in response

MSG6P (Message Prefix for LU62) and MSGOP (Message Prefix for OTMA) are mutually exclusive. Only one is present at any point. For SNAP PGM() SHOW() purposes, the MSG6P and MSGOP are treated as synonyms. Specifying either MSG6P or MSGOP displays, if available, whichever of the two blocks is present.

**REGION**

Captures control block information for the dependent region specified in the *region#* parameter. The *region#* parameter specified must be numeric, in the range 1 - 999, and identify a currently active dependent region. Multiple *region#* parameters can be specified with each parameter separated by a comma or a blank.

The dependent region might also be identified using the SNAP JOBNAME(*jobname*) format of the SNAP REGION() resource type. The *jobname* parameter specified must be alphanumeric, no longer than eight characters, and identify a currently active dependent region. Multiple *jobname* parameters can be specified with each parameter separated by a comma or a blank. The REGION(*region#*) and JOBNAME(*jobname*) formats can both be specified on the same command.

The control blocks that can be captured for a dependent region are listed in the following table. Primary control blocks for a dependent region, which are always present and available for capture, are identified by the column labeled "Primary". Optional control blocks for a dependent region, which might be present and available for capture based on workload and other factors, are identified by the column labeled "Optional".

Table 267. /DIAGNOSE SNAP REGION() control blocks

| Name  | Block description                      | Macro    | Primary | Optional | System | Application |
|-------|--|----------|---------|----------|--------|-------------|
| VTD   | SVC Vector Table Directory Entry       | DFSVDIR  | X       |          | X      |             |
| ASCB  | MVS Address Space Control Block        | IHAASCB  |         | X        | X      |             |
| ASSB  | MVS Address Space Secondary Block      | IHAASSB  |         | X        | X      |             |
| DPDIR | Dependent Region Directory Block       | DFSDPDIR |         | X        | X      |             |
| IWALE | Internal Work Area List Elements Block | DFSIQALE |         | X        | X      |             |

Table 267. /DIAGNOSE SNAP REGION() control blocks (continued)

| Name    | Block description                          | Macro    | Primary | Optional | System | Application |
|---------|--|----------|---------|----------|--------|-------------|
| LESEP   | Local External Entry Table Prefix Block    | DFSLESEP |         | X        | X      |             |
| DRAT    | DRA Thread Control Block                   | DFSDRAT  |         | X        | X      |             |
| IDT     | Identify Table Entry                       | DFSIDT   | X       |          | X      |             |
| TCB     | MVS Task Control Block (IDT)               | IKJTCB   |         | X        | X      |             |
| TCB     | Task Control Block (PST)                   | IKJTCB   |         | X        | X      |             |
| SAP     | Save Area Prefix block                     | ISAP     | X       |          | X      |             |
| DSPWRK1 | Dispatch Block: Work Area Part 1 (current) | IDSPWRK  |         | X        | X      |             |
| DSPWRK2 | Dispatch Block: Work Area Part 2 (current) | IDSPWRK  |         | X        | X      |             |
| TCB     | MVS Task Control Block (CDSP)              | IKJTCB   |         | X        | X      |             |
| RB      | MVS Associated Request Block (CDSP)        | IHARB    |         | X        | X      |             |
| RBP     | MVS Associated Request Block Prefix (CDSP) | IHARB    |         | X        | X      |             |
| XSB     | MVS Extended Status Block (CDSP)           | IHAXSB   |         | X        | X      |             |
| DSPWRK1 | Dispatcher Block: Work Area Part 1 (home)  | IDSPWRK  |         | X        | X      |             |
| DSPWRK2 | Dispatcher Block: Work Area Part 2 (home)  | IDSPWRK  |         | X        | X      |             |
| DSPPST  | PST Dispatching Control Block              | IDSPWRK  |         | X        | X      |             |
| XMCI    | Cross-Memory Control Block, ITASK Level    | DFSXMC   |         | X        | X      |             |
| SSVPL   | System Service Parameter List Block        | DFSSSVPL |         | X        | X      |             |
| DMIB    | Directed Message Manager Interface Block   | DFSDMIB  |         | X        | X      |             |
| CULE    | Common Use List Element Block              | DFSCULE  |         | X        | X      |             |
| CLLE    | Common Latch List Element Block            | DFSCLLE  |         | X        | X      |             |
| LSMB    | Logging Secondary Master Block             | DFSLSMB  |         | X        | X      |             |
| SSIDX   | Subsystem Status Index Entry               | DFSSSIE  | X       |          | X      | X           |
| LCRE    | Local Current Recovery Entry               | DFSLCRE  | X       |          | X      | X           |
| RRE     | Residual Recovery Element Block (LCRE)     | DFSRRE   |         | X        |        | X           |
| TIB     | APPC Transaction Instance Block            | DFSTIB   |         | X        |        | X           |
| YTIB    | OTMA Transaction Instance Block            | DFSYTIB  |         |          |        |             |

Table 267. /DIAGNOSE SNAP REGION() control blocks (continued)

| Name    | Block description                           | Macro    | Primary | Optional | System | Application |
|---------|---|----------|---------|----------|--------|-------------|
| PCENTRY | Protected Conversation Task Table Entry     | DFSRRSIB |         | X        |        | X           |
| RRE     | Residual Recovery Element Block (PC)        | DFSRRE   |         | X        |        | X           |
| PST     | Partition Specification Table               | IPST     | X       |          | X      | X           |
| CNT     | Communication Name Table                    | ICLI     |         | X        |        | X           |
| SMB     | Scheduler Message Block                     | IAPS     |         | X        |        | X           |
| SQPST   | Scheduler Queue Element                     | ISQPST   |         | X        |        | X           |
| UOW     | Unit of Work Value (QMGR)                   | DFSUOWE  |         | X        |        | X           |
| UOWE    | Unit of Work Table Entry                    | DFSUOWE  |         | X        |        | X           |
| EPFXH   | Extended Message Prefix Header              | DFSEPFXH |         | X        |        | X           |
| MSGBP   | Basic 01/03 Message Prefix                  | QLOGMSGP |         | X        |        | X           |
| BSGEP   | Extended Message Prefix                     | QLOGMSGP |         | X        |        | X           |
| PDIR    | Program Directory Block                     | DFSPDIR  |         | X        |        | X           |
| PSB     | Program Specification Block                 | DFSPSB   |         | X        |        | X           |
| TLS     | Transaction Level Statistics Area           | DFSTLS   |         | X        |        | X           |
| DACCT   | DL/I Call Statistics Area                   | DFSDACCT |         | X        |        | X           |
| MSCEB   | MSC Message Routing Exit Interface Block    | DFSMSCEB |         | X        |        | X           |
| D2AFB   | DB2 RRS Attach Facility Interface Block     | DFSD2AF  |         | X        |        | X           |
| OLRW    | Online Reorganization Work Area Block       | DFSOLRW  |         | X        |        | X           |
| ISIT    | Intersubsystem Interface Table              | IPST     |         | X        |        | X           |
| DIRCA   | Interregion Communication Area Block        | IRC      |         | X        |        | X           |
| EPST    | Extended Partition Specification Table      | DBFEPST  |         | X        |        | X           |
| DSTA    | DBCTL Statistics Area Block                 | DFSDSTA  |         | X        |        | X           |
| RRE     | Residual Recovery Element Block (PST)       | DFSRRE   |         | X        |        | X           |
| P62XT   | LU 6.2 PST Extension Block                  | DFSP62XT |         | X        |        | X           |
| WLM     | Workload Manager Work Area Block            | DFSWLMWK |         | X        |        | X           |
| RSSMP   | RAS System Security Message Prevention List | DFSRSSMP |         | X        |        | X           |

**SHOW keyword parameters for the /DIAGNOSE SNAP REGION command**

## **SHOW**

Specifies which blocks are returned. Using the SHOW() option, a single block, list of blocks, or group of blocks identified by the keyword can be returned. Example: **/DIAG SNAP REG(1)**

If the SHOW() option is omitted from the **/DIAGNOSE SNAP REGION()** command, only the primary control blocks for the dependent region are captured by default. The SNAP REGION() resource type supports the ALL, PRI, OPT, APP, and SYS keywords, and all block names listed in [Table 267 on page 487](#) as parameters to the SHOW() option.

### **ALL**

Captures all control blocks listed in [Table 267 on page 487](#) that are available. Example: **/DIAG SNAP REG(1) SHOW(ALL)**

### **PRI**

Captures the primary control blocks for the region. Primary control blocks are identified by the Primary column in [Table 267 on page 487](#). Example: **/DIAG SNAP REG(1) SHOW(PRI)**

### **OPT**

Captures all optional control blocks that are available. Optional control blocks are identified by the Optional column in [Table 267 on page 487](#). Example: **/DIAG SNAP REG(1) SHOW(OPT)**

### **APP**

Captures all application control blocks that are available. Control blocks that are part of the application group are identified by the Application column in [Table 267 on page 487](#). Example: **/DIAG SNAP REG(1) SHOW(APP)**

### **SYS**

Captures all system control blocks that are available. Control blocks that are part of the system group are identified in the System column in [Table 267 on page 487](#). Example: **/DIAG SNAP REG(1) SHOW(SYS)**

### ***blockname***

Captures the specified block by block name. Block names are defined in the Name column in [Table 267 on page 487](#). Example: **/DIAG SNAP REG(1) SHOW(IDT)**

### ***blockname,blockname***

Captures multiple blocks by block name. Example: **/DIAG SNAP REG(1) SHOW(VTD,SAP)**

### ***keyword,blockname***

Captures a group of blocks by keyword and individual blocks by block name. Example: **/DIAG SNAP REG(1) SHOW(SYS,PDIR)**

## **Usage notes for the /DIAGNOSE SNAP REGION command**

DRAT (DRA Thread Control Block) is available only in a DBCTL environment. If the SHOW(ALL) or SHOW(SYS) option is specified in a non-DBCTL environment, the DRAT is ignored. If the SHOW(DRAT) option is specified in a non-DBCTL environment, a DFS110I message is issued.

DSTA (DBCTL Statistics Area Block) is available only in a DBCTL environment. If the SHOW(ALL) or SHOW(SYS) option is specified in a non-DBCTL environment, the DSTA is ignored. If the SHOW(DSTA) option is specified in a non-DBCTL environment, a DFS110I message is issued.

EPST (Extended Partition Specification Table) is available only in an IMS system where Fast Path is defined. If the SHOW(ALL) or SHOW(APP) option is specified in a non-Fast Path environment, the EPST is ignored. If the SHOW(EPST) option is specified in a non-Fast Path environment, a DFS154I message is issued.

TIB (APPC Transaction Instance Block) and YTIB (OTMA Transaction Instance Block) are mutually exclusive. Only one is present at any time. For SNAP REGION() SHOW () purposes, TIB and YTIB are treated as synonyms. Specifying either TIB or YTIB displays whichever of the two blocks is present.

The SNAP JOBNAME(*jobname*) format of the SNAP REGION() resource type cannot be used to identify a CCTL thread. All CCTL threads have the same job name and the CICS region, and therefore it is impossible to identify the correct thread by the job name.

If multiple regions are started with the same job name, only the first region will be found using the SNAP JOBNAME(*jobname*) format of the SNAP REGION() resource type.

VTD, ASCB, ASSB, DPDIR, IWALE, LESEP, DRAT, and IDT are not available for an OLR region. If the SHOW(ALL), SHOW(PRI), or SHOW(SYS) option is specified for an OLR region, these blocks are ignored. If any of these blocks are explicitly specified with the SHOW option for an OLR region, a DFS2859I message is issued.

## RM

Specifies the scope of the resource search for certain resource types. The RM() parameter is optional and applicable only to the LTERM(), NODE(), and USER() resource types.

Valid values for the RM() parameter are:

### YES

If YES is specified or the RM() parameter is omitted, a local search is performed for the requested resource. If a local copy of the resource is found, that copy is used. If a local copy of the resource is not found, and a Resource Manager is available, a second search is performed on the RM for the resource. If a global copy of the resource is found, that copy is used.

### NO

If NO is specified, only a local search for the resource is performed.

### ONLY

If ONLY is specified, only a global search on the Resource Manager is performed. If RM(ONLY) is specified and a Resource Manager is not available, a DFS2859I message is issued with reason text RM(ONLY) INVALID, RM UNAVAILABLE, and the command is not processed.

## SHOW

Specifies which control blocks are captured by the SNAP function. The SHOW parameter is optional. Valid filtering values for the *keyword* and *blockname* parameters are listed in each section that describes a SNAP resource type. SHOW(PRI) is the default.

## STRUCTURE

Captures information about the DFSSQS control block storage for the specified shared queues structure. STRUCTURE(ALL) is the default.

## TRAN

Captures information about the transaction specified in the *traname* parameter. This keyword captures the SMB data for a specified transaction.

## USER

Captures control block information about the user name specified in the *username* parameter. The *username* parameter specified must be alphanumeric, no longer than 8 characters, and identify a currently defined user name. Multiple *username* parameters can be specified with each parameter separated by a comma or a blank.

The control blocks that can be captured for user names are listed in the following table. Primary control blocks for a user name, which are always present and available for capture, are identified by the column labeled "Primary". Optional control blocks for a user name, which might or might not be present and available for capture depending on workload and other factors, are identified by the column labeled "Optional".

Table 268. /DIAGNOSE SNAP USER() control blocks

| Name     | Block description             | Macro   | Primary | Optional |
|----------|-------------------------------|---------|---------|----------|
| SPQB     | Subpool Queue Block           | ICLI    | X       |          |
| EPF      | Event Control Block Prefix    | IEPF    |         | X        |
| CULE     | Common Use List Element Block | DFSCULE |         | X        |
| DSPWRK1  | Dispatcher Work Area          | IDSPWRK |         | X        |
| SAP      | Save Area Prefix              | ISAP    |         | X        |
| SAVEAREA | Save Area Set                 | REQUATE |         | X        |
| PROLOG   | Module Prolog Information     | N/A     |         | X        |

Table 268. /DIAGNOSE SNAP USER() control blocks (continued)

| Name    | Block description                 | Macro    | Primary | Optional |
|---------|-----------------------------------|----------|---------|----------|
| CLB     | Communication Line Block          | ICLI     |         | X        |
| CTB     | Communication Terminal Block      | ICLI     |         | X        |
| CTT     | Communication Translate Table     | ICLI     |         | X        |
| CRB     | Communications Restart Block      | ICLI     |         | X        |
| SPQBEXT | Subpool Queue Extension Block     | ICLI     |         | X        |
| EMHB    | Expedited Message Handler Block   | DBFEMHB  |         | X        |
| SMB     | Scheduler Message Block           | IAPS     |         | X        |
| TIB     | APPC Transaction Instance Block   | DFSTIB   |         |          |
| YTIB    | OTMA Transaction Instance Block   | DFSYTIB  |         | X        |
| CNT     | Communication Name Table          | ICLI     |         | X        |
| ECNT    | Extended Communication Name Table | DBFECNT  |         | X        |
| CRTCN   | Command CART & 4-Byte Console ID  | DFSMCSC  |         | X        |
| CCB     | Conversational Control Block      | ICLI     |         | X        |
| CIB     | Communication Interface Block     | ICLI     |         | X        |
| MSGBP   | Basic 01/03 Message Prefix        | QLOGMSGP |         | X        |
| UOWE    | Unit of Work Table Entry          | DFSUOWE  |         | X        |
| INBUF   | Input Line Buffer                 | N/A      |         | X        |
| OUTBUF  | Output Line Buffer                | N/A      |         | X        |
| RAQE    | VTAM Receive Any IO Buffer (In)   | BUFVTPRE |         | X        |
| RAQERES | VTAM Receive Any IO Buffer (Out)  | BUFVTPRE |         | X        |

**SHOW keyword parameters for the /DIAGNOSE SNAP USER command**

**SHOW**

Specifies which blocks are returned. If the SHOW keyword is omitted from the /DIAGNOSE SNAP USER command, only the primary control blocks for the user name are captured by default. The SNAP USER() resource type supports the ALL, OPT, and PRI keywords, and all block names that are listed in [Table 268 on page 491](#) as parameters for the SHOW keyword. Multiple SHOW parameters can be specified with each parameter separated by a comma or a blank. A maximum of 32 SHOW parameters can be specified.

The effects of the SHOW option on the data that is captured by the /DIAGNOSE SNAP USER command are described in the following list:

**ALL**

Captures all control blocks listed in [Table 268 on page 491](#) that are available. Example: /DIAGNOSE SNAP USER(IMSUS04) SHOW(ALL).

**OPT**

Captures all optional control blocks that are available. Optional control blocks are identified by the Optional column in [Table 268 on page 491](#). Example: /DIAGNOSE SNAP USER(IMSUS04) SHOW(OPT).



**PRI**

Captures the primary control blocks for the user. Primary control blocks are identified by the Primary column in [Table 268 on page 491](#). Example: `/DIAG SNAP USER(IMSUS04) SHOW(PRI)`.

**blockname**

Captures the specified block by block name. Block names are defined in the Name column in [Table 268 on page 491](#). Example: `/DIAGNOSE SNAP USER(IMSUS04) SHOW(SPQB)`.

**blockname,blockname**

Captures multiple blocks by block name. Example: `/DIAGNOSE SNAP USER(IMSUS04) SHOW(SPQB,EPF)`.

**keyword,blockname**

Captures a group of blocks by keyword and individual blocks by block name. Example: `/DIAG SNAP USER(IMSUS04) SHOW(PRI,EPF)`.

**Usage notes for the /DIAGNOSE SNAP USER command**

The **/DIAGNOSE SNAP USER** command is available only in a DB/DC or DCCTL environment.

The following control blocks are available only in an IMS system where Fast Path is defined.

- ECNT (Extended Communication Name Table)
- EMHB (Expedited Message Handler Block)
- SMB (Scheduler Message Block)
- TIB (APPC Transaction Instance Block)
- YTIB (OTMA Transaction Instance Block)

If the SHOW(ALL) or SHOW(OPT) option is specified in a non-Fast Path environment, these blocks are ignored. If the SHOW(ECNT), SHOW(EMHB), SHOW(SMB), SHOW(TIB), or SHOW(YTIB) option is specified in a non-Fast Path environment, a DFS154I message is issued in response.

UOWE (Unit of Work Table Entry) block is available only in an IMS system where shared queues are defined. If the SHOW(ALL) or SHOW(APP) option is specified in a non-shared-queues environment, UOWE is ignored. If the SHOW(UOWE) option is specified in a non-shared-queues environment, a DFS154I message is issued in response.

TIB (APPC Transaction Instance Block) and YTIB (OTMA Transaction Instance Block) are mutually exclusive; only one is present at any given time. For SHOW() purposes, TIB and YTIB are treated as synonyms. Specifying either TIB or YTIB displays, if available, whichever of the two blocks is present.

The SHOW(PROLOG) option displays information about the modules that are associated with the save areas in the chain. The module entry point is obtained from the saved register 15 value of the previous save area. If SHOW(SAVEAREA) is combined with SHOW(PROLOG), the display consists of a save area followed by the related prolog of the module that uses the save area.

The SHOW(RECANY) option displays information about both RAQE (VTAM Receive Any IO Buffer (In)) and RAQERES (VTAM Receive Any IO Buffer (Out)) control blocks.

The SHOW(SA) option is a synonym for the SHOW(SAVEAREA) option.

**Usage notes**

One of the key uses for the **/DIAGNOSE SNAP MODULE(modname)** command is to return the entry point address of a module. With the **/DIAGNOSE SNAP MODULE(modname)** command, users can determine the entry point address of the target module without having to create a console dump to set an MVS SLIP trap.

Another important use for the **/DIAGNOSE SNAP MODULE(modname)** command is to extract the prolog information for a module. The prolog information for a module contains information about the current maintenance level of the module on your system. This can be useful to find out if there is any missing maintenance on your module. Establishing a common, or baseline, maintenance level can be useful in diagnosing difficult or complex problems.

## Examples

### Example 1 for /DIAGNOSE command

Entry ET:

```
/DIAGNOSE SNAP TRAN(tranname)
```

Response ET:

```
DFS058I DIAGNOSE COMMAND COMPLETED
```

**Explanation:** Diagnostic information about transaction *tranname* is captured and written to the IMS log.

### Example 2 for /DIAGNOSE command

Entry ET:

```
/DIAGNOSE SNAP BLOCK(ALL) OPTION(TRACE)
```

Response ET:

```
DFS058I DIAGNOSE COMMAND COMPLETED
```

**Explanation:** Diagnostic information about IMS control blocks is captured and written to the trace data sets.

### Example 3 for /DIAGNOSE command

Entry ET:

```
/DIAGNOSE SNAP BLOCK(CSCD)OPTION(OLDS)
```

Response ET:

```
DFS058I DIAGNOSE COMMAND COMPLETED
```

**Explanation:** Diagnostic information about APPC/OTMA SMQ SCD Extension control block is captured and written to the IMS log.

### Example 4 for /DIAGNOSE command

Entry ET:

```
/DIAGNOSE SNAP AREA(00010001)
```

Response ET:

```
/DIAGNOSE SNAP STORAGE DISPLAY
Resource: AREA(D0010001)

ALDS      DEDB Area Name List Entry      Loc: 09E0A590
-----
0000 C4F0F0F1 F0F0F0F1 09BF7E90 09B26A30 |D0010001..=.....|

DMAC      DEDB Area Control Block        Loc: 09B26A30
-----
0000 F1F2F1F8 C4C5C4C2 D1F0F0F1 C4F0F0F1 |1218DEDBJ001D001|
0010 F0F0F0F1 0010213F 2217081F 00000000 |0001.....|
0020 00000000 000001EF 00008000 00000E5B |.....$.|
0030 00000000 00000000 00000000 00000000 |.....|
0040 00000000 00000000 00000000 00000000 |.....|
0050 00000000 00000000 00000000 00000000 |.....|
0060 00000000 00000000 00000403 00000000 |.....|
0070 01C1000A 000F0019 00780002 00000200 |.A.....|
0080 000001F6 000003EA 00000005 00000000 |...6.....|
0090 00000000 00018000 00000000 01000101 |.....|
00A0 06088001 00000001 00000000 00000002 |.....|
```

```

00B0 00000000 00000000 40000000 00000000 | .....
00C0 00000000 00000000 00000000 09B267A0 | .....
00D0 00000000 00000000 00000000 40404040 | .....
00E0 001CB600 000001C7 00000000 00000000 | ..... G .....
00F0 00000000 00080600 00000000 0A12F618 | ..... 6 .....
0100 09A5B0FC 00000000 00010000 00000000 | . v .....
0110 00000000 00000000 00000000 00000000 | .....
0120 09A5B0FC 00000100 00401800 00000000 | . v .....
0130 00000000 00000000 00000000 00000000 | .....
0140 00000000 00000000 00000000 00000000 | .....
0150 00000000 00000000 00000000 00000000 | .....
0160 00000000 00000000 00000000 00000000 | .....
0170 00000000 00000000 00000000 00000000 | .....
0180 00000000 0000FFA6 000001EF 00000000 | ..... w .....
0190 00000000 00000000 00000000 00000000 | .....
01A0 00000000 00000000 00000000 00000000 | .....
01B0 00000000 00000000 00000000 00000000 | .....
01C0 00000000 00000000 00000000 00000000 | .....
01D0 00000000 00000000 00000000 00000000 | .....
01E0 00000000 00000000 00000000 00000000 | .....
01F0 00000000 00000000 00000000 00000000 | .....
0200 00000000 00000000 00000000 00000000 | .....
0210 00000000 00000000 00000000 00000000 | .....
0220 00000000 00000000 00000000 00000000 | .....
0230 00000000 00000000 00000000 00000000 | .....
0240 00000000 00000000 00000000 00000000 | .....
0250 00000000 00000000 00000000 00000000 | .....
0260 00000000 00000000 00000000 00000000 | .....
0270 00000000 00000000 00000000 00000000 | .....
0280 00000000 00000000 00000000 00000000 | .....
0290 00000000 00000000 00000000 25262D2E | .....
02A0 34142B20 D5D6E5FF 00161718 00000000 | ..... NOV .....
02B0 00010000 09A5C090 00000000 00000000 | ..... v .....
02D0 00000000 00000000 00000000 00000000 | .....
02E0 00000000 00000000 00000000 00000000 | .....
02F0 00000000 00000000 00000000 00000000 | .....
0300 00000000 00000000 00000000 00000000 | .....
0310 00000000 00000000 00000000 00000000 | .....
0320 00000000 00000000 00000000 00000000 | .....
0330 00000000 00000000 00000000 00000000 | .....
0340 00000000 00000000 00000000 00000000 | .....
0350 00000000 00000000 00000000 00000000 | .....
0360 09A5B0FC 00000000 00000000 00000000 | . v .....
0370 00000000 00000000 00000000 00000000 | .....
0380 00000000 00000000 00000000 00000000 | .....
0390 00000000 00000000 00000000 00000000 | .....
03A0 00000000 00000000 00000000 00000000 | .....
03B0 00000000 00000000 00000000 00000000 | .....
03C0 00000000 40404040 40404040 40404040 | .....
03D0 40404040 40404040 40404040 40404040 | .....
03E0 40404040 00000000 00000000 00000000 | .....
03F0 00000000 00000000 00000000 00000000 | .....
0400 00000000 00000000 00000000 00000000 | .....
0410 00000000 00000000 00000000 00000000 | .....
0420 00000000 00000000 00000000 00000000 | .....
0430 00000000 00000000 00000000 00000000 | .....
0440 00000000 00000000 00000000 00000000 | .....
0450 2010213F 22193984 2034028D 00000000 | ..... d .....
0460 00000000 00000000 00000000 00000000 | .....
0470 00000000 00000008 00000000 00000000 | .....
0480 00000000 00000000 C65DAC50 F91B8BE0 | ..... F) .&9 ...
0490 00000000 00000000 00000000 00000000 | .....
04A0 00000000 00000000 00000000 00000000 | .....
04B0 00000000 00000000 00000000 00000000 | .....
04C0 00000000 00000000 09B0D000 00000000 | .....
04D0 00000000 00000000 00000000 00000000 | .....
04E0 00000000 00000000 00000000 00000000 | .....
04F0 00000000 00000000 00000000 00000000 | .....
0500 00000000 00000000 | .....
*10213/152244*

```

**Explanation:** Diagnostic information about the primary control blocks for the area is captured, formatted, and displayed on the issuing LTERM.

**Example 5 for /DIAGNOSE command**

Entry ET:

```
/DIAGNOSE SNAP AREA(D0010001) SHOW(ALDS)
```

Response ET:

```
/DIAGNOSE SNAP STORAGE DISPLAY
Resource: AREA(D0010001)

ALDS      DEDB Area Name List Entry      Loc: 09E0A590
-----
0000 C4F0F0F1 F0F0F0F1 09BF7E90 09B26A30 |D0010001..=.....|
*10213/152259*
```

**Explanation:** Diagnostic information about the ALDS control block for the area is captured, formatted, and displayed on the issuing LTERM.

**Example 6 for /DIAGNOSE command**

Entry ET:

```
/DIAGNOSE SNAP AREA(D0010001,D0010002) SHOW(ALDS)
```

Response ET:

```
/DIAGNOSE SNAP STORAGE DISPLAY
Resource: AREA(D0010001)

ALDS      DEDB Area Name List Entry      Loc: 09E0A590
-----
0000 C4F0F0F1 F0F0F0F1 09BF7E90 09B26A30 |D0010001..=.....|

Resource: AREA(D0010002)

ALDS      DEDB Area Name List Entry      Loc: 09E0A5A0
-----
0000 C4F0F0F1 F0F0F0F2 09BF7E90 09B26F38 |D0010002..=...?.|
*10213/152311*
```

**Explanation:** Diagnostic information about the ALDS control block for areas D0010001 and D0010002 is captured, formatted, and displayed on the issuing LTERM.

**Example 7 for /DIAGNOSE command**

Entry ET:

```
/DIAGNOSE SNAP AREA(D0010001) SHOW(ALDS,ADSC)
```

Response ET:

```
/DIAGNOSE SNAP STORAGE DISPLAY
Resource: AREA(D0010001)

ALDS      DEDB Area Name List Entry      Loc: 09E0A590
-----
0000 C4F0F0F1 F0F0F0F1 09BF7E90 09B26A30 |D0010001..=.....|

ADSC      DEDB Area Data Set Control Block Loc: 09A5B0FC
-----
0000 C4F0F0F1 F0F0F0F1 C9D4E2E3 C5E2E3D3 |D0010001IMSTESTL|
0010 4BC4F0F0 F1F0F0F0 F1404040 40404040 |.D0010001
0020 40404040 40404040 40404040 40404040 |
0030 40404040 00008003 08000000 10000000 |
0040 09B26A30 09A5B040 00000000 F9000000 |.....v. ....9...|
0050 00000000 00000000 00000000 01CF1380 |
0060 00000000 00000000 00000200 00000200 |
0070 00000000 00000000 00000000 00000000 |
0080 00000000 00000000 00000000 00000000 |
0090 00000000 00000000 00000000 00000000 |
00A0 00000000 00000000 00000000 00000000 |
00B0 00000000 00000000 00000000 |
*10213/152558*
```

**Explanation:** Diagnostic information about the ALDS and ADSC control blocks for the area is captured, formatted, and displayed on the issuing LTERM.

**Example 8 for /DIAGNOSE command**

Entry ET:

```
/DIAGNOSE SNAP MSNAME(LINK31V6) SHOW(PRI)
```

Response ET:

```
/DIAGNOSE SNAP STORAGE DISPLAY
Resource: MSNAME(LINK31V6)

LNB      Link Name Block                               Loc: 0C67C800
-----
0000 00000000 00000000 00000000 00000000 |.....|
0010 00000000 00820084 00000000 D3C9D5D2 |...b.d...LINK|
0020 F3F1E5F6 00100021 00053D30 00000000 |31V6.....|
0030 00000000 00000000 00000000 00000000 |.....|
0040 0C67C878 00000000 0004F150 00000000 |.H.....1&...|
0050 013F01B7 00000000 00000000 00000000 |.....|
0060 00000000 00000000 00000000 00000000 |.....|
*12216/072150*
```

**Explanation:** Diagnostic information about the primary control blocks for MSNAME LINK31V6 is captured, formatted, and displayed on the issuing LTERM.

**Related concepts**

[/DIAGNOSE command SNAP function \(Diagnosis\)](#)



---

## Chapter 27. /DISPLAY commands

Use the IMS **/DISPLAY** commands to display the processing status of IMS message queues and processing resources.

The **/DISPLAY** commands can provide helpful information for controlling IMS operations.

These commands can be issued to an IMSplex using the Batch SPOC utility.

The output from a **/DISPLAY** command consists of headings that describe the display, the information requested, and a time stamp showing Julian date and time, in one of the following two formats:

```
yyddd/hhmmss  
yyyyddd/hhmmss
```

You control the time stamp format by specifying the YEAR4= execution parameter.

The value shown in the QCNT column of the command output has different meanings for different commands, as described in individual **/DISPLAY** command topics.

If the command includes a generic parameter that does not match any existing resource, an error message results.

In an IMSplex, when status is copied to RM at signoff/logoff time, the status (and control blocks if the resource is dynamic) is deleted from the local system. An Automated Operator Interface (AOI) application program that issues a **/DISPLAY** command will not see some status information that is kept in RM if the IMS system on which the AOI program runs is not using RM services. When a **/DISPLAY** command is issued for NODE, USER, and LTERM resources from the command master, global status from RM might be displayed. The output of the display command will be dependent on the following guidelines:

### Command master IMS system

- Displays information from the local system
- Displays information from RM that is not owned, or is owned by a failed system

### Other IMS systems

Displays information from the local system



**Attention:** Using ALL, generic parameters, the **/DISPLAY STATUS** command, and the **/DISPLAY CONVERSATION** command without a specific resource name will result in extensive accesses to the Resource Manager for global information, and their use should be carefully considered.

Subsections:

- [“Status and attributes for the /DISPLAY command” on page 501](#)
- [“/DISPLAY ACT command” on page 514](#)
- [“/DISPLAY AFFIN command” on page 529](#)
- [“/DISPLAY AOITKN command” on page 531](#)
- [“/DISPLAY APPC command” on page 532](#)
- [“/DISPLAY AREA command” on page 534](#)
- [“/DISPLAY ASMT command” on page 540](#)
- [“/DISPLAY CCTL command” on page 549](#)
- [“/DISPLAY CONV command” on page 552](#)
- [“/DISPLAY CPLOG command” on page 556](#)
- [“/DISPLAY CQS command” on page 557](#)
- [“/DISPLAY DB command” on page 557](#)
- [“/DISPLAY DBD command” on page 567](#)

- [“/DISPLAY DESC command” on page 568](#)
- [“/DISPLAY FDR command” on page 569](#)
- [“/DISPLAY FPV command” on page 570](#)
- [“/DISPLAY HSSP command” on page 572](#)
- [“/DISPLAY LINE command” on page 574](#)
- [“/DISPLAY LINK command” on page 578](#)
- [“/DISPLAY LTERM command” on page 581](#)
- [“/DISPLAY LUNAME command” on page 585](#)
- [“/DISPLAY MASTER command” on page 590](#)
- [“/DISPLAY MODIFY command” on page 591](#)
- [“/DISPLAY MSNAME command” on page 603](#)
- [“/DISPLAY NODE command” on page 605](#)
- [“/DISPLAY OASN SUBSYS command” on page 616](#)
- [“/DISPLAY OLDS command” on page 617](#)
- [“/DISPLAY OTMA command” on page 620](#)
- [“/DISPLAY OVERFLOWQ command” on page 625](#)
- [“/DISPLAY PGM command” on page 628](#)
- [“/DISPLAY POOL command” on page 630](#)
- [“/DISPLAY PSB command” on page 648](#)
- [“/DISPLAY PTERM command” on page 650](#)
- [“/DISPLAY Q command” on page 652](#)
- [“/DISPLAY QCNT command” on page 656](#)
- [“/DISPLAY RECOVERY command” on page 660](#)
- [“/DISPLAY RTCODE command” on page 666](#)
- [“/DISPLAY SHUTDOWN STATUS command” on page 667](#)
- [“/DISPLAY STATUS command” on page 672](#)
- [“/DISPLAY STRUCTURE command” on page 679](#)
- [“/DISPLAY SUBSYS command” on page 680](#)
- [“/DISPLAY SYSID TRANSACTION command” on page 683](#)
- [“/DISPLAY TIMEOVER command” on page 684](#)
- [“/DISPLAY TMEMBER command” on page 685](#)
- [“/DISPLAY TRACE command” on page 697](#)
- 
- [“/DISPLAY TRAN command” on page 707](#)
- [“/DISPLAY UOR command” on page 711](#)
- [“/DISPLAY USER command” on page 715](#)

### **Related concepts**

[Displaying components and resources \(System Administration\)](#)



## Status and attributes for the /DISPLAY command

A list of the attributes and status shown in the **/DISPLAY** command are described in the following table.

Table 269. Attributes and status in the /DISPLAY command

| Status or attribute    | Meaning  |
|------------------------|--|
|                        | Indicates no status for the resource.  |
| ACCEPT TRAFFIC         | OTMA is ready to accept messages from this member.   |
| ACT MODETBL            | Indicates the mode table name actually used to initiate mode.  |
| ACTIV                  | Indicates that this node is in an XRF session, on the active system.   |
| ACTIVE, A              | Indicates one of the following: <ul style="list-style-type: none"> <li>• Conversation in progress.</li> <li>• For <b>/DISPLAY MODIFY</b>, the routing code (RTCODE) named is active or that the library is active.</li> <li>• The IMS subsystem is the active subsystem.</li> <li>• The current XRF surveillance mechanism is active.</li> <li>• The OTMA member is in an active z/OS cross-system coupling facility (XCF) group.</li> <li>• The secondary master terminal is active.</li> </ul> |
| ACTIVE-DBCMD           | Indicates an <b>/DBD</b> or <b>/DBR</b> command is in progress and waiting for the region to terminate before the <b>/DBD</b> or <b>/DBR</b> can complete.   |
| ACTIVE-RRS             | The APPC/OTMA shared queues enablement is active, and z/OS Resource Recovery Services (RRS) is used for communication between front-end and back-end systems for all synchronization levels.   |
| ACTIVE-RRS/XCF         | The APPC/OTMA shared queues enablement is active, and z/OS cross-system coupling facility (XCF) is used for communication between front-end and back-end systems if synchronization level is NONE or CONFIRM. For synchronization level SYNCPOINT, RRS is used for communication between front-end and back-end systems.   |
| ACTIVE-XCF             | The APPC/OTMA shared queues enablement is active, and XCF is used for communication between front-end and back-end if synchronization level is set to NONE or CONFIRM. Transactions of synchronization level SYNCPOINT are queued with affinity to the front-end system.   |
| ACTV                   | Indicates, for a logical link, that link startup processing is complete and the line is available for message transfer.  |
| ALLOC                  | Indicates that an ISC user is allocated. The node name to which the user is allocated or signed on follows in parentheses.   |
| ALLOCATION IN PROGRESS | Indicates that a conversation is in the process of being allocated.  |
| ALLOCF                 | Indicates that database allocation failed.   |
| ALLOCS                 | Indicates that database allocation was successful.   |
| AREA                   | The subset of a DEDB.  |
| AUTOSR                 | Indicates a session initiation option of ASR.  |

Table 269. Attributes and status in the /DISPLAY command (continued)

| Status or attribute            | Meaning  |
|--------------------------------|--|
| AVAILABLE                      | Indicates one of the following: <ul style="list-style-type: none"> <li>• The OLDS can be reused.</li> <li>• A region is available to schedule an application.</li> <li>• A coupling facility structure is available for use by IMS.</li> </ul>   |
| AWAITING RESPONSE              | Indicates that an active terminal is waiting for a response.   |
| AWAITING SNAPQ                 | Indicates that the alternate subsystem is waiting for <b>/CHE SNAPQ</b> from the active subsystem.   |
| BACKOUT                        | Indicates that the OLDS is potentially required for backout or, in the case of a database, there are incomplete backouts that prevent the use of the database.   |
| BACKUP                         | Indicates that the IMS subsystem is the alternate subsystem.   |
| BAL                            | Identifies a transaction eligible for load balancing (for example, with parallel limits specified). The current maximum number of regions that can be simultaneously scheduled to process the transaction follows in parentheses.  |
| BCKUP                          | Indicates that this node is in an XRF session, on the alternate system.  |
| C1INOP, C2INOP, C3INOP, C4INOP | Indicates the inoperable node or terminal component, where C1, C2, C3, and C4 refer to different components as defined by system definition. (See the <b>/COMPT</b> and <b>/RCOMPT</b> commands for details on how to ready inoperable components.)  |
| CANCEL                         | Indicates that an APPC connection was stopped by the <b>/STOP APPC CANCEL</b> command.   |
| CHECK                          | Indicates that the OTMA client is using RACF for security verification.  |
| CLSER                          | Indicates that an error occurred while closing the OLDS.   |
| CLSDST                         | Indicates that a <b>/CLSDST</b> or <b>/STOP</b> command has been entered for a VTAM node but has not yet taken effect. This condition can occur because of an outstanding input or output operation that has not completed. The VTAM network operator can issue a z/OS <b>VARY</b> command to clear the condition. |
| COLD                           | For an MSC logical link, indicates that link startup processing is not complete.<br><br>For a SLUP or FINANCE terminal, indicates that the next session initiation is cold (message sequence numbers are initialized to 0.)  |
| COMPINOP                       | Indicates an inoperable terminal component. For 3270 terminals, this is an indication that either the display or the printer is not ready.   |
| CON                            | Indicates that a node is connected, or in session, with IMS.   |
| CONN                           | Subsystem connection.  |
| CONN, ACTIVE                   | Indicates that an application program has established communication with a subsystem.  |
| CONNECTED                      | Indicates that IMS is connected to a coupling facility structure.  |
| CONN IN PROGRESS               | Subsystem connection in progress.  |

Table 269. Attributes and status in the /DISPLAY command (continued)

| Status or attribute      | Meaning   |
|--------------------------|---|
| CONVACT, CONV-ACT        | Indicates an active conversation on this terminal, node, or user.   |
| CONVERSATION TERM/USER   | <p>Indicates for <b>/DISPLAY MODIFY</b> that the transaction to be changed or deleted or the transaction that references a program or database to be changed or deleted is in conversation. The terminal originating the conversational transaction and the conversation ID are also displayed.</p> <p>The terminal displayed is:</p> <ul style="list-style-type: none"> <li>• <b>nodename</b> for VTAM terminals</li> <li>• <b>nodename</b> and <b>username</b> if an ETO user is signed on to the node</li> <li>• <b>username</b> for ETO users who signed off while in conversation</li> <li>• <b>lin#-pte#</b> (line and pterm number) for non-VTAM terminals</li> <li>• <b>1- SC</b> for the system console</li> </ul> |
| CONVHLD, CONV-HLD        | Indicates a held conversation on this terminal, node, or user.  |
| COPY-PHASE               | Indicates that the CREATE utility is currently in COPY-PHASE for an ADS.  |
| CREATED                  | Indicates the XCF group has been created, but the OTMA member has not yet connected to it.  |
| DB-STOPD                 | Indicates that a database used by this program is stopped.  |
| /DBD ACTIVE              | A <b>/DBDUMP</b> command is in progress for a database to be changed or deleted.  |
| /DBR ACTIVE              | A <b>/DBRECOVERY</b> command is in progress for a database to be changed or deleted.  |
| DEACT (DEACTIVATED)      | Indicates a physical terminal/node or line has been permanently deactivated. Restart of non-VTAM node requires <b>/STOP DC</b> and <b>/START DC</b> commands. Message DFS2473 in the system console log might contain information regarding the reason this status was set. DFS2473 can occur more than once in the system console log.   |
| DEADQ                    | Indicates a user with dead letter queues or whose last access time was outside the limit set by the DLQT JCL parameter. The DEADQ status can be removed by signing on the user or entering the <b>/DEQUEUE</b> or <b>/ASSIGN</b> command.   |
| DEALLOCATION IN PROGRESS | Indicates that a conversation is in the process of being deallocated.   |
| DEQCT                    | Number of local message dequeues since the last IMS cold start or, in a shared-queue environment, since the last IMS restart. DEQCT is reset to zero when ENQCT reaches 32768. A DEQCT count can equal the sum of the DEQCTs of multiple destinations (logical terminals or transactions).  |
| DISABLED                 | Indicates APPC/IMS is not known to APPC/z/OS.   |
| DISCONNECTED             | <p>Indicates one of the following:</p> <ul style="list-style-type: none"> <li>• A node is not in session.</li> <li>• The OTMA client has disconnected from the XCF group.</li> <li>• IMS is not connected to a coupling facility structure.</li> </ul>  |

Table 269. Attributes and status in the /DISPLAY command (continued)

| Status or attribute     | Meaning  |
|-------------------------|--|
| DQF                     | Indicates a dequeue request for OTMA REPresynch command failed.  |
| DYNAMIC                 | A transaction was built in a shared-queues environment to enable transaction messages to be enqueued, but the transaction cannot run on the current IMS subsystem.   |
| EEQE                    | Extended error queue element, indicates that one or more error queue elements are associated with the database.  |
| ELIGIBLE FOR SCHEDULING | Indicates that the transaction is eligible for scheduling and cannot be deleted by online change. Stop the transaction before attempting another online change commit.   |
| ENABLED                 | Indicates that APPC is started.  |
| ENQCT                   | Number of local message enqueues since the last IMS cold start, or in a shared-queue environment, since the last IMS restart. ENQCT is reset to the number of messages on queue (QCT) when the counter reaches 32768 (QCT = ENQCT - DEQCT). The ENQCT can exceed 32768 if the DEQCT remains zero. The ENQCT will be reset to zero if the counter exceeds 65535. An ENQCT count can equal the sum of the ENQCTs of multiple destinations (logical terminals or transactions). |
| ERE                     | Indicates, for a logical link, that link startup processing is not complete. When the link is started, emergency restart synchronization will be performed, because the previous link shutdown was either not normal or an IMS emergency restart was performed.  |
| EXCL                    | Indicates a node, terminal, or user is in exclusive mode.  |
| FAILED                  | Indicates one of the following: <ul style="list-style-type: none"> <li>• APPC failed to start.</li> <li>• OTMA failed to join the XCF group or the XCF group failed initialization. Check the DFSPBxxx PROCLIB member for the OTMA group name and member name definition. You might have defined an incorrect or duplicate XCF member name for IMS OTMA.</li> </ul>  |
| FILLING                 | Indicates that a log gap is currently being filled.  |
| FLOOD                   | Indicates that input from the tmember is suppressed because of a message flood condition.<br><br>Check if the flood was caused by stopped IMS programs or hung regions. Sometimes it could be caused by bad I/O response time.   |
| FORCE, FORCES           | Indicates a session initiation option of FORCE.  |
| FORCE-RRS               | The APPC/OTMA shared queues enablement is active, and RRS is used for communication between front-end and back-end systems for all synchronization levels. All transactions are queued without affinity even if one IMS system has the APPC/OTMA shared queues enablement not active.  |

Table 269. Attributes and status in the /DISPLAY command (continued)

| Status or attribute   | Meaning   |
|---|---|
| FORCE-RRS/XCF   | The APPC/OTMA shared queues enablement is active, and XCF is used for communication between front-end and back-end systems if synchronization level is NONE or CONFIRM. For synchronization level SYNCPOINT, RRS is used for communication between front-end and back-end systems. All transactions are queued without affinity even if one IMS system has the APPC/OTMA shared queues enablement not active. |
| FORMAT-PHASE  | Indicates that the CREATE utility is currently in FORMAT-PHASE for an ADS.  |
| FULL  | Indicates that the OTMA client is using RACF for security verification, including for dependent regions.  |
| GLOBAL QUEUE COUNT<br>INTERNAL ERROR, GLOBAL<br>QUEUE COUNT STORAGE ERROR | Indicates that IMS is unable to access global queue counts or obtain storage to query the queue counts.   |
| IC  | Indicates that image copy is in progress for that area or database by an HSSP region.   |
| IDLE  | Indicates that no activity of any kind is in progress for a line, node, or logical link. This is a common condition for VTAM node channel-to-channel links, and processor storage-to-processor storage links.   |
| IDLE-Cxx  | When the Multiple Systems Coupling (MSC) TCP/IP link is in IDLE state, asynchronous output might still be in progress and the link is waiting for that response. xx represents the following values:<br><b>X'10'</b><br>A response is owed for data.<br><b>X'16'</b><br>A response is owed for stop bracket initiation (SBI) or bracket initiation stopped (BIS).   |
| INACTIVE  | The APPC/OTMA shared queues enablement is inactive. If AOS=Y is specified, the global status might change to active if the IMS member that does not support the APPC and OTMA shared queues enablement leaves the shared queues group. A back-end system will still be able to process messages from a front-end system even with status INACTIVE.  |
| INACTIVE, I   | Indicates that the current XRF surveillance mechanism is inactive. For the /DISPLAY MODIFY command, indicates that the library is inactive.   |
| INOP  | Indicates that a terminal or node is inoperable.  |
| IN-OVERFLOW   | Indicates that a coupling facility structure is in overflow mode.   |
| INPUT IN PROGRESS   | Indicates input in progress for an active terminal.   |
| INQONLY   | Indicates a /DBDUMP command was issued for the database.  |
| IN SLOWDOWN   | Indicates that the OTMA member is experiencing a slowdown because of excessive message traffic or resource constraints.<br><br>Check the XCF configuration in your environment.   |

Table 269. Attributes and status in the /DISPLAY command (continued)

| Status or attribute               | Meaning  |
|-----------------------------------|--|
| INUSE, IN USE                     | Indicates that queuing is in process for this transaction. (either terminal input or program-to-program switch). Also indicates this is the OLDS currently being used.   |
| INVALID SUBSYSTEM NAME = XXXX     | Indicates that a subsystem name was not defined to IMS.  |
| I/O PREVEN, I/O PREVENT, I/O PREV | Indicates a BMP program that contains GSAM cannot complete scheduling because I/O prevention has not completed. Indicates further I/O requests to data sets are inhibited.   |
| I/O TOLERATION                    | Takeover process by which an alternate IMS subsystem ensures database integrity and enables new transaction processing as soon as possible.  |
| JOIN                              | Indicates that the OTMA client is using RACF only to authorize the client connection at the time of the client bid request. No transaction, command, or dependent region security checking is performed for individual messages.   |
| LOCK                              | Indicates a node, terminal, transaction, program, or database is locked.   |
| LOOPTEST                          | Indicates a line or terminal in looptest mode.   |
| LOST                              | Indicates that the VTAM LOSTERM EXIT has been scheduled for this node but has not yet been recognized by IMS. At the next interrupt for this node, IMS will interrogate the LOSTERM value.<br><br>All values result in an immediate CLSDST, or disconnection, from IMS.  |
| MAX TPIPE                         | The total number of tpipes reaches the maximum number.<br><br>To resolve this flood condition for TPIPE limit, issue the IMS / <b>CHECKPOINT</b> command three times to clear the unused OTMA TPIPE, or restart IMS. Also, examine your TPIPE limit in the OTMA member descriptor in the DFSYDTx PROCLIB member. |
| MESSAGES WAITING                  | Indicates that there are system messages waiting to be sent, which prevents shutdown from completing.  |
| MFSTEST, MFST                     | Indicates a terminal, node, or user in MFSTEST mode.   |
| MSG IN QUEUE                      | Indicates that there are messages in the queue for an active terminal.   |
| MSG CT                            | Number of messages on the queue for this destination (calculated by subtracting the DEQCT from ENQCT).   |
| N/A                               | Indicates that a link is not assigned or a user is signed on to a static terminal, in which case queues are not applicable.  |
| NEEDED                            | Indicates the OLDS that needs to be archived.  |
| NO ACTIVE CONVERSATION            | Indicates that there is no active conversation between a logger and a log router.  |
| NODE-USR                          | Node name and user identifier.   |
| NOIN                              | Indicates a line or terminal stopped for input.  |
| NO INPUTTING LINES                | Indicates no terminal activity.  |

Table 269. Attributes and status in the /DISPLAY command (continued)

| Status or attribute      | Meaning   |
|--------------------------|---|
| NO LOG ROUTER SG DEFINED | Indicates that there is no Log Router Service Group defined to DBRC.  |
| NONE                     | Indicates that the OTMA client is not using RACF for security verification.   |
| NOOUT                    | Indicates a line or terminal stopped for output.  |
| NO OUTPUTTING LINES      | Indicates no terminal activity.   |
| NOQUEUE                  | Indicates a line or terminal that has had message queuing stopped for message switching.  |
| NOT CONN                 | No subsystem connection.  |
| NOT DEFINED              | Indicates the OTMA member has left the XCF group (for example, because of a <b>/STOP OTMA</b> command).<br>Restart the OTMA client to join the XCF group.   |
| NOTIDLE s                | Indicates that a logical link is waiting for the completion of a synchronous event. The s represents the following subcodes:<br><b>A</b><br>Indicates a status of NOTIDLE-POST, which means that an event has completed but the link has not been dispatched to process it.<br><b>B</b><br>Indicates a status of NOTIDLE-IWAIT, which means the link is waiting for completion of internal I/O.<br><b>Cxx</b><br>Indicates a status of NOTIDLE-TP WAIT, which means the link is waiting for completion of a TP access method request. The two characters xx indicate the value of the access method operation code. Blanks are displayed if the link is VTAM.<br>For MSC TCP/IP links, xx indicates the following:<br><b>X'20'</b><br>A response is owed for a restart request. |
| NOTINIT                  | Indicates a database or program for which directory initialization failed or indicates DMB or PSB pool space not large enough to accommodate blocks. Indicates a TRAN that could not be initialized.  |
| NOTOPEN, NOT-OPEN        | Indicates a database, area, line, terminal, or physical link that is not in open status. This status is not applicable to MSDBs.  |
| NOT USABLE               | Indicates a log data set (OLDS) is unusable because of previous error.  |
| NRE                      | Indicates, for a logical link, that link startup processing is not complete. When the link is started, normal restart synchronization will be performed, because the previous link shutdown or IMS restart was normal.  |
| OLR                      | Indicates that the database has online reorganization in progress   |
| OPEN                     | Indicates that the VTAM ACB is open. Indicates an area to be changed or deleted is open.  |
| OPNDST                   | Indicates that an OPNDST is in process for this node.   |

Table 269. Attributes and status in the /DISPLAY command (continued)

| Status or attribute    | Meaning   |
|------------------------|---|
| OUTBOUND               | Indicates that the alternate subsystem is APPC-enabled. Also shown on active subsystem when APPC processing cannot start.   |
| OUTPUT IN PROGRESS     | Indicates output in progress for an active terminal.  |
| PAGE                   | Indicates an MFS paged message.   |
| PERMNT ERR             | Indicates that there is a permanent error, such as a read error, that prevents a log gap from being filled.   |
| PRE-OPEN FAILED        | Pre-open for ADS failed.  |
| PREV CLSER             | Indicates that the previous OLDS could not be closed because of an I/O error; therefore, this OLDS is required by the Log Recovery utility to correct the condition.  |
| PRI                    | Indicates that this node is the primary partner of an ISC session; or, for a link, indicates that it is the primary partner of an MSC-VTAM session.   |
| PRIMARY MSTR           | Indicates that the terminal is the primary master terminal.   |
| PROFILE                | Indicates that the OTMA client is using values in the Security Data section of the message prefix for a transaction.  |
| PRST                   | Indicates that a terminal or user is in preset destination mode. The destination trancode or logical terminal name follows in parentheses.  |
| PSB SCHEDULED          | A program that references a database to be changed or deleted is scheduled.   |
| PSTOPPED (PSTO, PSTOP) | Indicates a line, terminal, transaction, or logical link that has been pstopped. This status can indicate that a different, necessary resource is unavailable. For example, a transaction could show a status of PSTOP because the associated program is not initialized.   |
| PUR, PURGING           | Indicates a transaction, line, or terminal that is purging all of its output.   |
| QCT                    | Number of messages on the queue for this destination (calculated by subtracting the DEQCT from ENQCT).  |
| QERR, QERROR           | Indicates that an I/O error occurred on the queue for this LTERM, or remote transaction (MSC).  |
| QLOCK                  | Indicates that the LTERM is locked from sending any further output or from receiving input which could create additional output for the same LTERM until the state is reset by a specific request received on the session.  |
| QSTP                   | Indicates that transaction queuing is stopped by online change because the transaction is affected by the online change. Online change might be changing or deleting the transaction, or changing or deleting a program, PSB, database, or DMB referenced by the transaction. Transaction queuing is stopped until the online change is committed or aborted. |
| QUEUING <i>nn</i>      | Indicates that messages are queued to the transaction to be changed or deleted, and <i>nn</i> is the number of messages queued.   |



Table 269. Attributes and status in the /DISPLAY command (continued)

| Status or attribute       | Meaning  |
|---------------------------|--|
| QUI                       | Indicates that a VTAM node has sent a VTAM Quiesce-End-of-Chain indicator to suspend IMS output.   |
| QUIESCED                  | Indicates one of the following: <ul style="list-style-type: none"> <li>• The OTMA member is temporarily quiesced. Restart the member or OTMA.</li> <li>• The node is stopped.</li> <li>• The database is currently quiesced by a previous <b>UPDATE DB START(QUIESCE)</b> or <b>UPDATE AREA START(QUIESCE)</b> command.</li> </ul>   |
| QUIESCING                 | Indicates that the database is undergoing quiesce by a previous <b>UPDATE DB START(QUIESCE)</b> or <b>UPDATE AREA START(QUIESCE)</b> command.  |
| REBLD-INPROG              | Indicates that a CQS structure rebuild is in progress for a structure.   |
| RECALL                    | Indicates that database or area is in recall.  |
| RECD                      | The number of messages that are received from the specified node.<br><br>For static terminals, this is the number of messages that are received since the last IMS cold start, warm start, or emergency restart. The count is not reset when a static terminal logs off or logs on.<br><br>For dynamic terminals, this is the number of messages that are received since the current user signed on to the dynamic terminal. The count is reset when a user signs off from the dynamic terminal, and following a cold start, warm start, or emergency restart. |
| RECOVERY                  | Requests the display of recovery values that pertain to the node or user. For the <b>/DISPLAY DB</b> command, indicates that DRF recovery is in progress for that database.  |
| RECOVERY-NEEDED, RECOVERN | Indicates areas that need recovery.  |
| RELREQ (NODE)             | Indicates that the VTAM RELREQ exit routine has been driven but IMS is waiting for an operation in progress to complete before releasing the node.   |
| REP                       | Indicates that IMS is waiting for an OTMA REPresynch command from the client.  |
| REQ                       | Indicates that IMS is sending an OTMA REQresynch command to the client.  |
| RESP                      | Indicates that the node, line, terminal, or user is in input response mode and the response reply message is available for output or in the process of being sent.   |
| RESPINP, RESP-INP         | Indicates the terminal, line, node, or user is in full-function input response mode and the response mode input is still in-doubt; for example, the response reply message is not available for output.  |
| RESP-INP-FP               | Indicates the terminal, line, node, or user is in Fast-Path input response mode and the response mode input is still in-doubt; for example, the response reply message is not available for output.  |

Table 269. Attributes and status in the /DISPLAY command (continued)

| Status or attribute | Meaning   |
|---------------------|---|
| RESYNC              | Indicates that the positive acknowledgment for an IMS recoverable output message was not received when the connection with the VTAM node was terminated. This message will be subject to resynchronization when the next connection for this node is attempted.   |
| RNL                 | Randomizer is not loaded for a DEDB database.   |
| RSF                 | Indicates that a reset request failed for an OTMA REPresynch command.   |
| SCHEDULED           | Indicates that a conversation, transaction, or program has been received and queued. For a conversation, this status will be displayed from the time an input message is entered until the output message is dequeued. With <b>/DISPLAY MODIFY</b> , indicates that the named resource (a transaction or program to be changed or deleted, or a program referencing a database to be changed or deleted) is scheduled. With <b>/DISPLAY OLDS</b> , indicates that an archive job had been generated.                                    |
| SEC                 | Indicates that this node is the secondary partner of an ISC session; or, for a link, indicates that it is the secondary partner of an MSC-VTAM session.   |
| SECOND MSTR         | Indicates that the terminal is the secondary master terminal.   |
| SENDING LOGS        | Indicates that a logger has an active conversation with a log router and is sending logs to the tracking site.  |
| SENT                | <p>The number of messages that are sent from the specified node.</p> <p>For static terminals, this is the number of messages sent since the last IMS cold start, warm start, or emergency restart. The count is not reset when a static terminal logs off or logs on.</p> <p>For dynamic terminals, this is the number of messages sent since the current user signed on to the dynamic terminal. The count is reset when a user signs off from the dynamic terminal, and following a cold start, warm start, or emergency restart.</p> |
| SERVER              | Indicates that the OTMA client is acting as the server.   |
| SEVER+FLOOD         | <p>Indicates that the global flood limit was specified in client descriptor or in the <b>/START TMEMBER ALL INPUT</b> command, and IMS has reached this OTMA global message flood limit.</p> <p>To resolve the OTMA global flood condition, examine each OTMA client and identify the pending message counts for each client. A client with too many unprocessed messages might have triggered the flood. Examine also any stopped programs and hung regions.</p>   |
| SEVERE-ERROR        | Indicates that ADS encountered a severe error.  |
| SHUT                | Indicates that normal processing has completed for the node and a VTAM shutdown-complete indicator was returned to IMS. The node can receive IMS output but cannot enter data while in this state.  |
| SHUTDOWN-STRCHKPT   | Indicates that CQS will take a structure checkpoint during normal shutdown.   |

Table 269. Attributes and status in the /DISPLAY command (continued)

| Status or attribute                                 | Meaning   |
|---|---|
| SIGN  | Indicates that a terminal or user is signed on to a node under enhanced security. The user signed on to the node is shown in parentheses following SIGN.  |
| SIMLOGON  | Indicates that a logon to IMS has been simulated.   |
| SMQ BACKEND   | Indicates that this OTMA member has been created at the shared queues back-end IMS to process transaction messages. However, this member has no XCF connection to this IMS.   |
| SPND  | Indicates that a transaction had messages on the suspend queue.   |
| /STA ACTIVE   | A /START DB command is in progress for a database to be changed or deleted.   |
| STARTING  | Shown after /DIS CONV is issued and before the status is set to SCHEDULED. Indicates that a conversation has been received but is not eligible for scheduling to an application program until an end-of-message indication is received. Also shown after /START APPC is issued and before the status is set to ENABLED or FAILED. |
| STATIC  | Indicates that the node, LTERM, or user was defined during system definition.   |
| STOP IN PROGRESS                                    | Indicates a /STOP SUBSYS command is in progress.  |
| STOPPED, STO, STOP                                  | Indicates an area, line, LTERM, LU name, node, terminal, user, OLDS, subsystem, transaction, routing code (RTCODE), OTMA client, program, or database that is stopped. Indicates that a subsystem connection is stopped. Indicates a /STOP SERVGRP command was issued. Indicates that a transaction pipe is stopped.              |
| STO-INPUT   | Indicates one of the following: <ul style="list-style-type: none"> <li>The terminal is stopped with input messages enqueued to the LU name.</li> <li>The OTMA member has been stopped by the IMS command /STOP TMEMBER <i>member-name</i>. No new input from this member will be accepted.</li> </ul>                             |
| STO-OUTP  | Indicates that the terminal is stopped with output message enqueued to the LU name.   |
| STRCHKPT-INPROG                                     | Indicates that a CQS structure checkpoint is in progress for a structure.   |
| SUBSYSTEM XXXX NOT DEFINED BUT RECOVERY OUTSTANDING | Indicates that the subsystem was not defined but IMS has outstanding recovery elements.   |
| SUSPENDED   | Indicates that the transaction has been suspended. For /DISPLAY MODIFY, indicates that the transaction to be changed or deleted is on the suspend queue.  |
| SUSPENDED LOGS                                      | Indicates that a logger has an active conversation with a log router but has suspended sending logs to the tracking site because of resource shortage. The conversation is still intact.  |
| SYNCHRONIZING, SYN                                  | Indicates that the alternate subsystem is processing a /CHE SNAPQ command from the active subsystem. Indicates that a transaction pipe is being synchronized.   |

Table 269. Attributes and status in the /DISPLAY command (continued)

| Status or attribute  | Meaning  |
|----------------------|--|
| SYNC P2P             | This status is displayed for the OTMA DFSYICAL member, which is created internally to process synchronous program switch requests.   |
| SYNC P2P+FLOOD       | OTMA is experiencing a message flood condition for synchronous program switch.<br><br>To resolve this message flood for synchronous program switch, the flood limit can be increased by issuing the <b>/START TMEBER DFSYICAL INPUT higher_flood_limit</b> command.  |
| SYS CONSOLE          | Indicates that the terminal is the system console.   |
| TAKEOVER IN PROGRESS | Indicates that the alternate subsystem is taking over workload from the active subsystem.  |
| TAKEOVER REQUESTED   | Indicates that the active subsystem has requested a takeover by the alternate subsystem.   |
| TBR                  | Indicates that IMS is waiting for an OTMA TBResynch command from the client.   |
| TERM IN PROGRESS     | Indicates an internal termination of the subsystem.  |
| TERMINATING          | Indicates that the application program is being terminated.  |
| TEST                 | Indicates a line, node, terminal, or user in test mode.  |
| TKOTRA               | Indicates that a node, line, link, or terminal in an XRF session is to be traced only during takeover, to help diagnose XRF terminal switch problems.  |
| TMP                  | Indicates that a transaction pipe is temporary.  |
| TRA                  | Indicates that the physical terminal, node, logical link, LU name, transaction, program, or transaction pipe is being traced.  |
| TRACKING             | Indicates that the XRF alternate subsystem is tracking the active subsystem.   |
| UNAVAILABLE, UNAVAIL | Indicates an ADS that is unavailable. Indicates that a region is unavailable because an application is using it, even though the application is not currently scheduled. The region is not available to any other application for use. Indicates that there are no records of a log gap at the active site; these records may have been deleted. Indicates that a coupling facility structure is not available for use by IMS. |
| UNKNOWN              | Indicates that the XCF member has an unknown status.<br><br>Restart OTMA or the OTMA client to join the XCF group.   |
| USTOP, USTOPPED      | Indicates that scheduling of transactions has been stopped because of unavailable data.  |
| UNSUPPORTED          | The APPC/OTMA shared queues enablement is not supported for this member. This status applies only to the local status. The IMS system has been started with AOS=N or AOS=F and RRS=N. This IMS system will never be able to support the APPC/OTMA shared queues enablement.  |
| VIR                  | Indicates that the DEDB area has the VSO option.   |

Table 269. Attributes and status in the /DISPLAY command (continued)

| Status or attribute | Meaning  |
|---------------------|--|
| WAIT <i>cond</i>    | <p>Indicates that the application program is waiting for the completion of an event. The <i>cond</i> represents the reason for waiting. The <i>cond</i> can be:</p> <p><b>AOI</b><br/>indicates that an AO application issued a GMSG call with the wait option specified, but there are no messages for the application to retrieve.</p> <p><b>BLOCKMOVER or BLKMVR</b><br/>indicates that an application control block cannot be loaded because the ACB block mover is busy. The application might be waiting in the block mover because of an IRLM failure.</p> <p><b>CMD/PENDING</b><br/>indicates that a /DBD command or a /DBR command is in progress.</p> <p><b>INPUT</b><br/>indicates that the application program is in wait-for-input (WFI) mode.</p> <p><b>INTENT or INTENT/POOL</b><br/>indicates one of two conditions:</p> <ol style="list-style-type: none"> <li>1. The application program's intent for a database conflicts with the use of the database by a scheduled program.</li> <li>2. A temporary shortage of DMB, PSB, of PSB work area pool space exists.</li> </ol> <p><b>I/O PREVEN</b><br/>indicates that a BMP region which accesses a GSAM database cannot schedule until I/O prevention has completed.</p> <p><b>MESSAGE</b><br/>indicates that the application program is in a pseudo wait-for-input mode. The application is scheduled and is waiting for a message.</p> <p><b>POOLSPACE or POOLSP</b><br/>indicates a temporary shortage of DMB, PSB, or PSB work area pool space exists.</p> <p><b>SWITCHOVER or SWITCH</b><br/>indicates that the alternate system is tracking the active system.</p> <p><b>SYNCPOINT</b><br/>indicates that the application in the region is now in sync point.</p> <p><b>WAIT-EPCB POOL</b><br/>indicates that there is a temporary shortage of EPCB pool space.</p> <p><b>WAIT-RRS/OTMA PC</b><br/>A program has a protected conversation with an OTMA client.</p> |
| WAIT BID            | <p>Indicates that the OTMA client is processing a Client-Bid request.</p> <p>Start the OTMA client to join the XCF group.</p>  |
| WAITING             | <p>Indicates that the MPP region is waiting for work. Indicates a log gap is not being filled yet.</p>   |

Table 269. Attributes and status in the /DISPLAY command (continued)

| Status or attribute | Meaning  |
|---------------------|--|
| WAIT RESPONSE       | Indicates that the OTMA member is processing a message and is waiting for a response from the server.<br><br>This status code might indicate a potential IMS OTMA error. Contact IBM Software Support. |
| WRERR               | Indicates a write I/O error on the OLDS or a database.   |

### Related tasks

Setting DEADQ status time with the DLQT parameter (Communications and Connections)

## /DISPLAY ACT command

Use the **/DISPLAY ACT** command to display region and DC information associated with an IMS system. The region is scheduled to an application program and the IMS resources are assigned.

Subsections:

- [“Environment” on page 514](#)
- [“Syntax” on page 514](#)
- [“Keywords” on page 514](#)
- [“Usage notes” on page 515](#)
- [“Output fields” on page 515](#)
- [“Examples” on page 522](#)

### Environment

The following table lists the environments (DB/DC, DBCTL, and DCCTL) in which you can use the command and keywords.

Table 270. Valid environments for the /DISPLAY ACT command and keywords

| Command / Keywords | DB/DC | DBCTL | DCCTL |
|--------------------|-------|-------|-------|
| <b>/DISPLAY</b>    | X     | X     | X     |
| ACT                | X     | X     | X     |
| DC                 | X     |       | X     |
| REGION             | X     | X     | X     |

### Syntax

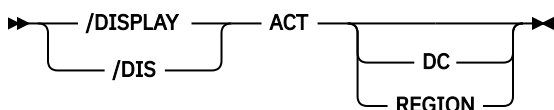

### Keywords

The following keywords are valid for the **/DISPLAY ACT** command:

## DC

Displays only the DC subset of the output. The DC portion of the display can include:

- The status of active VTAM ACBs. If MNPS is used for XRF, then both the APPLID ACB and the MNPS ACB are displayed. If MNPS is not active, only the APPLID ACB displays.
- User variable (USERVAR) name if using an XRF. If MNPS is active, USERVAR is invalid and is not displayed. Instead, the MNPS ACB name is displayed.
- VTAM generic resource name (GRSNAME) and its current status.
- The APPC IMS LU name, the APPC connection status, the APPC timeout value, and the APPC/IMS flood control limit for active APPC conversations.
- The APPC/OTMA SHARED QUEUE status, the number of RRS TCBs attached and the number of AWEs (work-elements) queued to the RRS TCBs.
- OTMA status.
- The TCP/IP generic resources GENIMSID value and status.
- The number of active LINES receiving input or sending output.
- The number of active NODES receiving input or sending output.
- The number of active LINKS (half sessions) receiving input or sending output.

## REGION

Displays only the REGION subset of the output. The display consists of active regions.

## Usage notes

When you issue the **/DISPLAY ACT** command from a specific environment, such as DCCTL, only the information that is valid for that environment is displayed.

ACTIVE-XCF, ACTIVE-RRS, and ACTIVE-RRS/XCF have similar values for local and global status.

### FORCE-RRS/XCF

The global status is ACTIVE-XCF because FORCE is a local status.

### ACTIVE-RRS

Both the local and global status is changed to INACTIVE if RRR becomes unavailable.

### ACTIVE-RRS/XCF

Both the local and global status is changed to ACTIVE-XCF if RRS becomes unavailable.

IMS creates a task to process the IMS catalog updates for a database definition change through the DDL or another process. The task is started when the **INIT DFSDMU** is issued by the application program changing the IMS catalog. The task is then shown among the other IMS regions with the **/DISPLAY ACT** command.

## Output fields

If **/DISPLAY ACT** command is issued, the output for both DC and REGION is displayed.

The following output fields are displayed for the **/DISPLAY ACT DC** command, and also for the **/DISPLAY ACT** command (no DC or REGION keyword specified):

### OTMA GROUP

Status of the IMS Open Transaction Manager Access (OTMA) group. The status can be either ACT or NOTACTIVE.

Only one OTMA group can be active at one time.

### VTAM ACB

The status of the VTAM ACB, which can be OPEN, CLOSE PENDING, or CLOSED. The status of LOGONS can be ENABLED or DISABLED. The base IMS LU name and the current APPC connection status are shown if IMS is running with an APPC/MVS-capable operating system.

The following are displayed for the VTAM ACB:

**APPLID=**

The application identification name for IMS. If MNPS is used with XRF, then it is the APPLID ACB.

**USERVAR=**

The user name for IMS. Only applicable for XRF-capable systems.

**GRSNAME=**

The VTAM generic resource name. Displayed as blanks if no generic resource name exists.

**Restriction:** IMS displays either the USERVAR or the GRSNAME. For non-XRF subsystems (no USERVAR specified), IMS displays the GRSNAME, which can be blank.

If the IMS system is XRF, the following fields are appended to the date/time stamp:

**RSEname**

Recoverable service element name

**System**

ACT or BACKUP

**MNPS=**

The MNPS ACB name if MNPS is used for XRF.

**QUEUED RRSWKS**

The number of RRS requests (work elements) currently queued to the RRS TCBs. The work elements might be queued to the RRS TCBs for work from the APPC or OTMA shared message queue function.

**STATUS**

Status can be one of the following:

**AWAITING SNAPQ**

Alternate system awaiting SNAPQ checkpoint from active

**SYNCHRONIZING**

Alternate system processing SNAPQ checkpoint

**TRACKING**

Alternate system is in process of tracking active system

**TAKEOVER REQUESTED**

Alternate system requests a takeover

**TAKEOVER IN PROGRESS**

Alternate system in process of taking over workload from active

**I/O TOLERATION**

New active system in I/O toleration phase of processing prior to becoming a true active system

**TCPIP\_GENIMSID**

The generic IMS ID that is used to participate in an MSC TCP/IP generic resource group. The value shown is the value specified on the GENIMSID parameter of the IMS DFSDCxxx member of the IMS.PROCLIB data set.

TCP/IP generic resources enable remote MSC systems to connect to an IMSplex without having to specify a specific IMS system.

If TCPIP\_GENIMSID displays a value, then the following STATUS field displays ACTIVE. If no value is shown, then the STATUS field displays DISABLED.

**STATUS**

Displays ACTIVE or DISABLED depending on whether a value is displayed in the TCPIP\_GENIMSID field.

The following output fields are displayed for the **/DISPLAY ACT REGION** command, and also for the **/DISPLAY ACT** command (no DC or REGION keyword specified):



**END TIME**

The time at which IMS will end this synchronous program switch request.

**REGID**

Region identifier. For DBCTL, the thread number is displayed.

**JOBNAME**

The name of the job processing in the region. If no regions of that type exist, the job name is set to MSGRGN, FPRGN, BATCHRGN, or DBTRGN, depending on the region type. DBTRGN is only displayed for systems that support DBT threads.

DBTRGN, BATCHRGN, or FPRGN is displayed for DBCTL.

**TYPE**

Type of application program processing in the region, or type of region. BMH, BMP, DBRC, DBT, DLS, and FPU are displayed for DBCTL.

The following region/program types can be displayed:

**BMH**

HSSP processing

**BMP**

Batch message processing

**BMPE**

Batch message processing for an external subsystem thread

**DBRC**

DBRC address space

**DBT**

DBCTL thread

**DLS**

DL/I address space

**FP**

Fast Path

**FPE**

Fast Path processing for an external subsystem

**FPM**

Fast Path message-driven program

**FPME**

Fast Path message-driven program for an external subsystem thread

**FPU**

Fast Path utility program

**FPUE**

Fast Path utility program for an external subsystem thread

**TP**

Teleprocessing

**TPE**

Message-driven program for an external subsystem thread

**TPI**

Transaction Program Instance. A CPI Communications driven transaction is running in the region

**TRAN**

The name of the target transaction in the request data of a DL/I ICAL request that initiated a synchronous program switch.

**TRAN/STEP**

Transaction code being processed by region, or NONE, if there are no regions of that type.

## PROGRAM

Name of the program processing in the region.

DFSCPIC is displayed for CPI Communications driven transaction programs that have not issued a DL/I APSB call to allocate a PSB.

For DBCTL, SB name is displayed.

## STATUS

Status of the region, which can be one of the following:

### ACTIVE-RRS

The z/OS Resource Recovery Services (RRS) enablement is active. The synchronous transaction inputs from APPC/OTMA with sync levels of NONE, CONFIRM, and SYNCPT with the RRS indicator are queued onto the shared queue. This status is equivalent to the existing status of ACTIVE and is for a setting combination of AOS=Y and RRS=Y.

### ACTIVE-XCF

The z/OS cross-system coupling facility (XCF) enablement is active. The synchronous transaction inputs from APPC/OTMA with sync levels of NONE and CONFIRM with the XCF indicator are queued onto the shared queue. This status is for either AOS=X or a setting combination of AOS=B and RRS=N.

### ACTIVE-RRS/XCF

The RRS enablement and the XCF enablement are both active. The synchronous transaction inputs from APPC/OTMA with sync level of SYNCPT with the RRS indicator are queued onto the shared queue. The synchronous transaction inputs with sync level of NONE and CONFIRM with the XCF indicator are queued onto the shared queue. This status is for a setting combination of AOS=B and RRS=Y.

### ACTIVE-DBCMD

A **/DBD**, **/DBR**, **UPD DB STOP(ACCESS)**, or **UPDATE DB STOP(UPDATES)** command is in progress and waiting for the region to terminate before the command can complete.

Or, an **/STA DB** command that was issued after a **/DBD** command is in progress. The **/STA DB** command is waiting for the region that is accessing the database by using a PROCOPT=GO PSB to terminate, and the region must terminate before the command can complete.

### AVAILABLE

The active threads are available. The region is available to schedule an application.

### FORCE-RRS

The synchronous transaction inputs with sync levels of NONE, CONFIRM, and SYNCPT with the RRS indicator are queued onto the shared queue (without any affinity). This status is equivalent to the existing status of FORCE where AOS=F is specified.

### FORCE-RRS/XCF

The synchronous transaction inputs with sync level of SYNCPT with the RRS indicator are queued onto the shared queue (without any affinity).

The XCF enablement is also active. The synchronous transaction inputs with sync levels of NONE and CONFIRM with the XCF indicator are queued onto the shared queue.

This status is equivalent to the combination of the existing status of FORCE where AOS=F is specified and the new status ACTIVE-XCF.

The status is for a setting combination of AOS=S. It is equivalent to the combination of the existing status of FORCE where AOS=F is specified and the new status ACTIVE-XCF.

### OLR-RUNNING

The region is an IMS system-created BMP region to process the HALDB online reorganization (HALDB OLR) for the partition name. For those regions that have OLR running, the region type is BMP, the job name is the DBD name, the transaction name is the partition name, and the program name is the partition name with a suffix of 0.

**OLR-ALTER-INPROG**

The region is an IMS system-created BMP region to process the OLR-ALTER for the HALDB database. For those regions that have OLR-ALTER in progress, the region type is BMP, the job name is the DBD name, the transaction name is the partition name, and the program name is the partition name with a suffix of 0.

**SCHEDULING**

The application program is being scheduled.

**TERMINATING**

A dependent region or application program is being terminated.

**TERM-ABDUMP IN-P**

A **/STOP REGION ABDUMP** command has been issued, an SRB has been scheduled for the region, and abnormal termination is in progress.

**TERM-ABDUMP PEND**

A **/STOP REGION ABDUMP** command has been issued, but an abnormal termination SRB has not been scheduled because the region is in an ineligible state.

**TERM-ABDUMP SCHD**

A **/STOP REGION ABDUMP** command has been issued and an abnormal termination SRB has been scheduled for the region.

**TERM-BCKOUT IN-P**

Abnormal termination is in progress and backout processing has been initiated.

**TERM-THREAD TERM**

Region termination is in progress. For abnormal termination, either a **/STOP REGION ABDUMP** command was issued or the region encountered an error and terminated independently. For normal termination, either a **/STOP REGION** command was issued or the application program completed and terminated independently.

**TERM-PENDING**

A **/STOP REG** command was issued for a region which is in a condition where SIGN-ON and IDENTIFY has been done for the region, but a CREATE-THREAD has not yet been performed on IMS. The **/STOP REG** could not stop the region. A **/STOP REGION ABDUMP FORCE** command must be issued to stop a region with this status. This status only valid for MPP and JMP Region.

**TERM-WAIT SYNCPT**

Region termination is in progress and the application in the region is in the sync point.

When a dependent region is found in this state, a continuation line is inserted into the display, which shows the recovery unit ID (URID) and the originating IMS system ID (ORIGIN) that are associated with the transaction processing in the dependent region.

**TERM-WAIT RRS**

Region termination is in progress and the application in the region is in the sync point. This status is displayed when an application has a protected conversation with an OTMA client that is processing a sync point. The sync point can continue after the OTMA client issues either an SRRCMIT or SRRBACK call. This status is also displayed when the application program is part of a cascaded family and is processing a sync point. RRS cascaded transaction support is used by APPC/OTMA SMQ enablement to synchronize the back-end and front-end systems.

When a dependent region is found in this state, a continuation line is inserted into the display, which shows the recovery unit ID (URID) and the originating IMS system ID (ORIGIN) that are associated with the transaction processing in the dependent region.

**UNAVAILABLE**

An active DBT thread is unavailable. An application is using the region, even though the application is not currently scheduled. This region is therefore not available to any other application.

**WAIT-AOI**

An AO application issued a GMSG call with the WAITAOI subfunction specified, but there are no messages for the AO application to retrieve.

**WAIT-BLOCKMOVER**

An application control block cannot be loaded because the ACB block mover is busy. The application might be waiting in the block mover because of an IRLM failure.

**WAIT-CALLOUT**

The application program in the region is waiting for a response to a synchronous callout or synchronous program switch message.

When a dependent region is found in this state and is waiting for a synchronous callout message, a continuation line is inserted into the display, which shows the target member (TMEM) and the transaction pipe (TPIPE) that are associated with the transaction processing in the dependent region.

When the dependent region is waiting for a synchronous program switch message, the continuation line displays the target transaction code and when the synchronous program switch request will time out. The time value is in the format YYDDD/HHMMSS.

**WAIT-CMD/PENDING**

A **/DBDUMP**, **/DBRECOVERY**, or **/START** command is in progress.

The status of the MPP region continues to show WAIT-CMD/PENDING until the command completes and the region is rescheduled. To clear a WAIT-CMD/PENDING status without rescheduling the MPP region, issue a **/STA DB** command against one of the databases in the intent list for the PSB used by the MPP region that failed to initially schedule. Issuing this command drains the scheduler subqueue (SUBQ) 4 and posts all PSTs there, including any suspended MPP regions.

**WAIT-EPCB POOL**

A temporary shortage of EPCB pool space exists.

**WAITING**

The MPP region is waiting for work.

**WAIT-INIT-INPROG**

Indicates a SIGN-ON and IDENTIFY is done for the region but a CREATE THREAD has not yet been performed on IMS. This status only valid for MPP and JMP Region. A **/STOP REGION ABDUMP FORCE** command must be issued to stop a region with this status.

**WAIT-INPUT**

The application program is in WAIT-FOR-INPUT (WFI) mode.

**WAIT-INTENT**

The application program's intent for a database conflicts with the use of the database by a scheduled program.

**WAIT-INTENT/POOL**

Indicates either the application program's intent for a database conflicts with the use of the database by a scheduled program, or a temporary shortage of DMB, PSB, or PSB work area pool space exists.

**WAIT-INTENT SCHED**

The IMS transaction scheduler detected an application scheduling intent failure. (For example, Load Balancing.)

**WAIT-I/O PREVEN**

A BMP region that accesses a GSAM database cannot schedule until I/O prevention has completed.

**WAIT-MESSAGE**

The application program is in a pseudo WAIT-FOR-INPUT (WFI) mode. The application is scheduled and is waiting for a message.

**WAIT-POOLSPACE**

A temporary shortage of DMB, PSB, or PSB work area pool space exists.

**WAIT-QSC**

The application program (BMP, MPP, IFF, or DBCTL) is waiting for the quiesced state of a database that it tries to access to be released.

**WAIT-QSN**

The dependent region was placed in a wait state by the Queue Space Notification Exit (DFSQSPCO). If you are using a queue management product with IMS, refer to the product's documentation for further information on resolving this status.

**WAIT-RRS PC**

The application program has a protected conversation with an OTMA client that is processing a sync point. The sync point can continue after the OTMA client issues either an SRRCMIT or SRRBACK call. Or, the application program is part of a cascaded family and is processing a sync point. APPC/OTMA SMQ Enablement uses RRS cascaded transaction support to synchronize the back-end and the front-end system.

When a dependent region is found in this state, a continuation line is inserted into the display, which shows the recovery unit ID (URID) and the originating IMS system ID (ORIGIN) that are associated with the transaction processing in the dependent region.

**WAIT-SWITCHOVER**

The alternate system is tracking the active system.

**WAIT-SYNCPOINT**

The application in the region is now in SYNC POINT.

When a dependent region is found in this state, a continuation line is inserted into the display, which shows the recovery unit ID (URID) and the originating IMS system ID (ORIGIN) that are associated with the transaction processing in the dependent region.

**WAIT-XCF**

The application program has a standard conversation with an APPC or OTMA client that is processing a sync point. The sync point can continue after the client issues either a positive acknowledgment (ACK) or a negative acknowledgment (NAK). The APPC/OTMA SMQ enablement uses XCF to communicate between the back-end and the front-end IMS systems.

A standard conversation is indicating a synchronous SQ transaction with sync level of NONE or CONFIRM.

**TERM-WAIT XCF**

Region termination is in progress and the application in the region is in the sync point. This status is displayed when an application program has a standard conversation with an APPC or OTMA client that is processing a sync point. The sync point can continue after the client issues either an ACK or NAK. The APPC/OTMA SMQ enablement uses XCF to communicate between the back-end and front-end IMS systems.

When a dependent region is found in this state, a continuation line is inserted into the display. This line shows either the target member (TMEM) and the transaction pipe (TPIPE) for an OTMA client, or the network ID (NETWORKID) and the logic unit name (LUNAME) for an APPC client, and the originating IMS system ID (ORIGIN) that is associated with the transaction processing in the dependent region.

**TMEM**

A 1- to 16-alphanumeric character that displays the OTMA client target member.

**TPIPE**

A 1- to 8-alphanumeric character that displays the OTMA output message destination.

**LUNAME**

A 1- to 8-alphanumeric character NETWORK ID concatenated with a 1- to 8-alphanumeric character LU name.

**CLASS**

One of the classes associated with the region. The region can have from one to four classes, whose values range from 1 to 999.

## Examples

The examples of the /DISPLAY ACTIVE command are organized into the following three sections:

- [“Examples of /DISPLAY ACTIVE” on page 522](#)
- [“Examples of /DISPLAY ACTIVE DC” on page 525](#)
- [“Examples of /DISPLAY ACTIVE REG” on page 527](#)

The following are examples of the **/DISPLAY ACT** command.

### Examples of /DISPLAY ACTIVE

The following series of examples show the output of the **/DISPLAY ACTIVE** command for various configuration scenarios.

#### Example 1 for /DISPLAY ACT command

Entry ET:

```
/DISPLAY ACT
```

Response ET:

```
REGID JOBNAME  TYPE  TRAN/STEP PROGRAM  STATUS          CLASS
      MSGRGN   TP     NONE
      BATCHREG BMP    NONE
      FPRGN    FP     NONE
      DBTRGN   DBT    NONE
      1 IMSMPP0 TPE   DSN8PS  DSN8IP13       1, 3
      BATCHREG BMP    NONE
      FPRGN    FP     NONE
      DBR3CTA3 DBRC
      DLI3CTA3 DLS
VTAM ACB OPEN          -LOGONS ENABLED
APPLID=APPL8  GRSNAME=          STATUS=DISABLED
TCPIP_GENIMSID=          STATUS=DISABLED
LINE ACTIVE-IN - 1 ACTIV-OUT - 0
NODE ACTIVE-IN - 0 ACTIV-OUT - 4
LINK ACTIVE-IN - 0 ACTIV-OUT - 0
*89041/163619*
```

#### Example 2 for /DISPLAY ACT command

Entry ET:

```
/DISPLAY A
```

Response ET:

```
REGID JOBNAME  TYPE  TRAN/STEP PROGRAM  STATUS          CLASS
      1 I3YMPP  TP     WAITING          4, 1, 2, 3
      BATCHREG BMP    NONE
      FPRGN    FP     NONE
      DBRC     DBRC
VTAM ACB CLOSED
APPLID=APPL8  GRSNAME=          STATUS=DISABLED
TCPIP_GENIMSID=          STATUS=DISABLED
LINE ACTIVE-IN - 1 ACTIV-OUT - 0
NODE ACTIVE-IN - 0 ACTIV-OUT - 0
*11041/100117*
```

#### Example 3 for /DISPLAY ACT command

Entry ET:

```
/DISPLAY A
```

Response ET:

```
REGID JOBNAME TYPE TRAN/STEP PROGRAM STATUS CLASS
  2 I431MPP TP SKS7 DFSDLT7 1, 3, 6, 7
  3 IMS1BMP BMP REGION SIS04P01
  1 I431IFP FPM TXCDRN07 DDLTRN07
    R3 DBRC
VTAM ACB OPEN -LOGONS ENABLED
APPLID=APPL8 GRSNAME= STATUS=DISABLED
TCPIP_GENIMSID= STATUS=DISABLED
LINE ACTIVE-IN - 2 ACTIV-OUT - 0
NODE ACTIVE-IN - 0 ACTIV-OUT - 0
LINK ACTIVE-IN - 0 ACTIV-OUT - 0
*11041/144425* DFSRSENM ACTIVE
```

Explanation: The system is XRF capable so the date time stamp includes the RSE name and system indicator.

**Example 4 for /DISPLAY ACT command**

Entry ET:

```
/DISPLAY A
```

Response ET:

```
REGID JOBNAME TYPE TRAN/STEP PROGRAM STATUS CLASS
  1 I431MPP TP TXCDRN18 DDLTRN18 WAIT-INPUT 1, 3, 6, 7
    BATCHREG BMP NONE
  2 I431IFP FPM NO MSG. DDLTRN07
    R3 DBRC
VTAM ACB OPEN -LOGONS ENABLED
APPLID=APPL8 GRSNAME= STATUS=DISABLED
TCPIP_GENIMSID= STATUS=DISABLED
LINE ACTIVE-IN - 1 ACTIV-OUT - 0
NODE ACTIVE-IN - 0 ACTIV-OUT - 0
LINE ACTIVE-IN - 0 ACTIV-OUT - 0
*11041/132348* DFSRSENM ACTIVE
```

Explanation: Transaction TXCDRN18 is waiting for an input message. Program DDLTRN07 currently has no messages to process. Region 1 is in WAIT-FOR-INPUT (WFI) mode.

**Example 5 for /DISPLAY ACT command**

Entry ET:

```
/DISPLAY A
```

Response ET:

```
REGID JOBNAME TYPE TRAN/STEP PROGRAM STATUS CLASS
  2 I431MPP TP SKS7 DFSDLT7 WAIT-MESSAGE 1, 3, 6, 7
  3 IMS1BMP BMP REGION SIS04P01
  1 I431IFP FPM TXCDRN07 DDLTRN07
    R3 DBRC
VTAM ACB OPEN -LOGONS ENABLED
APPLID=APPL8 GRSNAME= STATUS=DISABLED
TCPIP_GENIMSID= STATUS=DISABLED
LINE ACTIVE-IN - 2 ACTIV-OUT - 0
NODE ACTIVE-IN - 0 ACTIV-OUT - 0
LINK ACTIVE-IN - 0 ACTIV-OUT - 0
*11041/144425* DFSRSENM ACTIVE
```

Explanation: Transaction SKS7 is waiting for an input message. Program DFSDLT7 currently has no messages to process. Region 2 is in Pseudo Wait-For-Input (PWFI) mode.

**Example 6 for /DISPLAY ACT command**

Entry ET:

```
/DISPLAY A
```

Response ET:

```
** SUBSYSTEM NAME **
  SYS3
REGID JOBNAME TYPE  TRAN/STEP PROGRAM  STATUS      CLASS
  2 I431MPP TP    SKS7      DFSDLT7 WAIT-MESSAGE 1,3,6,7
  3 IMS1BMP BMP   REGION    SIS04P01
  1 I431IFP FPM   TXCDRN07 DDLTRN07
    R3      DBRC
VTAM ACB OPEN      -LOGONS ENABLED
APPLID=APPL8      GRSNAME=      STATUS=DISABLED
TCPIP_GENIMSID=   STATUS=DISABLED
LINE ACTIVE-IN-   2 ACTIV-OUT-   0
NODE ACTIVE-IN-   0 ACTIV-OUT-   0
LINK ACTIVE-IN-   0 ACTIV-OUT-   0
*11041/144425* DFSRSENM ACTIVE
```

Explanation: Transaction SKS7 is waiting for an input message. Program DFSDLT7 currently has no messages to process. Region 2 is in Pseudo Wait-For-Input (WPFI) mode.

**Example 7 for /DISPLAY ACT command**

Entry ET:

```
/DISPLAY ACTIVE
```

Response ET:

```
REGID JOBNAME TYPE  TRAN/STEP PROGRAM  STATUS      CLASS
  1 IMSMPPA TPI   TPN1      DFSCPIC  WAIT-BLOCKMOVER 20, 22, 24, 26
  2 IMSMPPB TPI   TPN2      DFSCPIC  21, 23, 25, 22
  3 IMSMPPC TP    TPN3      SAAPSB1  28, 29, 24, 23
  4 IMSMPPD TPI   TPN4      DFSCPIC  WAIT-SYNCPPOINT 14, 15, 16, 17
  4 IMSMPPE TP    TRAN1     LU2PGMA  WAIT-INPUT      2, 4, 6, 8
  5 IMSMPPE TP    TRAN2     LU2PGMB  1, 3, 5, 7
VTAM ACB OPEN      / APPC LUNAME=IMSLUNME ENABLED -LOGONS ENABLED
APPLID=APPL8      GRSNAME=      STATUS=DISABLED
TCPIP_GENIMSID=   STATUS=DISABLED
LINE ACTIVE-IN -   2 ACTIV-OUT -   0
NODE ACTIVE-IN -   0 ACTIV-OUT -   0
LINK ACTIVE-IN -   0 ACTIV-OUT -   0
*90332/114253*
```

**Example 8 for /DISPLAY ACT command**

Entry ET:

```
/DISPLAY ACTIVE
```

Response ET:

```
REGID JOBNAME TYPE  TRAN/STEP PROGRAM  STATUS      CLASS
  1 IMSMPPA TP    NONE      WAITING      4, 1, 2
  2 IMS1BMP BMP   REGION    SIS04P01 WAIT-AOI
  4 IMS2BMP BMP   REGION    SIS04P02 WAIT-AOI
  3 I510MPP TP    NONE      WAIT-EPCB POOL 8, 8, 8, 8
  2 IMS3BMP BMP   NONE      WAIT-EPCB POOL
    FPRGN FP    NONE
    DBRC  DBRC
VTAM ACB CLOSED
APPLID=APPL8      GRSNAME=      STATUS=DISABLED
TCPIP_GENIMSID=   STATUS=DISABLED
LINE ACTIVE-IN -   1 ACTIV-OUT -   0
NODE ACTIVE-IN -   0 ACTIV-OUT -   0
*11280/095345*
```

**Example 9 for /DISPLAY ACTIVE command**

Entry ET:

```
/DISPLAY ACTIVE
```



Response ET:

```
REGID JOBNAME TYPE TRAN/STEP PROGRAM STATUS CLASS
      1 I431MPP TP                TERMINATING 1, 2, 3, 4
        BATCHREG BMP NONE
      2 I431IFP FPM NO MSG. DDLTRN07
        R3 DBRC
VTAM ACB OPEN -LOGONS ENABLED
APPLID=APPL8   GRSNAME=           STATUS=DISABLED
TCPIP_GENIMSID=           STATUS=DISABLED
LINE ACTIVE-IN - 1 ACTIV-OUT - 0
NODE ACTIVE-IN - 0 ACTIV-OUT - 0
LINE ACTIVE-IN - 0 ACTIV-OUT - 0
*11041/132348* DFSRSENM ACTIVE
```

Explanation: MPP region I431MPP is in the process of terminating because of a **/STOP REGION** command. Region 1 is in TERMINATING mode.

### Examples of /DISPLAY ACTIVE DC

The following series of examples show the output of the /DISPLAY ACTIVE DC command for various configuration scenarios.

#### Example 1 for /DISPLAY ACTIVE DC command

Entry ET:

```
/DISPLAY ACTIVE DC
```

Response ET:

```
VTAM STATUS AND ACTIVE DC COUNTS
VTAM ACB OPEN           -LOGONS ENABLED
IMSLU=SYS1.IMSLUNME     STATUS=ENABLED
APPLID=APPL8   USERVAR=IMS1
TCPIP_GENIMSID=           STATUS=DISABLED
LINE ACTIVE-IN -      2 ACTIV-OUT -      0
NODE ACTIVE-IN -      0 ACTIV-OUT -      0
LINK ACTIVE-IN -      0 ACTIV-OUT -      0
*11232/114253*
```

#### Example 2 for /DISPLAY ACTIVE DC command

Entry ET:

```
/DISPLAY ACTIVE DC
```

Response ET:

```
VTAM STATUS AND ACTIVE DC COUNTS
VTAM ACB CLOSED           -APPLID ACB
VTAM ACB OPEN           -LOGONS ENABLED -MNPS ACB
IMSLU=N/A.N/A   APPC STATUS=DISABLED TIMEOUT=  0  MAXC= 5000
OTMA GROUP=N/A           STATUS=NOTACTIVE
APPC/OTMA SHARED QUEUE STATUS - LOCAL=INACTIVE GLOBAL=INACTIVE
APPC/OTMA RRS MAX TCBS - 2 ATTACHED TCBS - QUEUED RRSWKS - 0  N
APPLID=APPL8   GRSNAME=           STATUS=DISABLED MNPS=APPL1
TCPIP_GENIMSID=           STATUS=DISABLED
LINE ACTIVE-IN -      1 ACTIV-OUT -      0
NODE ACTIVE-IN -      0 ACTIV-OUT -      0
LINK ACTIVE-IN -      0 ACTIV-OUT -      0
*11069/143346* DFSRSENM ACTIVE
```

Explanation: An XRF system is using MNPS. The MNPS ACB is APPL1, which is open and is accepting logons. The APPLID ACB is APPL8, but it is closed.

#### Example 3 for /DISPLAY ACTIVE DC command

Entry ET:

```
/DISPLAY ACTIVE DC
```

Response ET:

```
DFS000I VTAM STATUS AND ACTIVE DC COUNTS
DFS000I VTAM ACB OPEN -LOGONS DISABLED
DFS000I IMSLU=N/A.N/A APPC STATUS=DISABLED TIMEOUT= 0 MAXC= 5000
DFS000I OTMA GROUP=N/A STATUS=NOTACTIVE
DFS000I APPC/OTMA SHARED QUEUE STATUS - LOCAL=ACTIVE-XCF GLOBAL=ACTIVE-XCF
DFS000I APPC/OTMA SHARED QUEUES LOGGING=Y
DFS000I APPC/OTMA RRS MAX TCBS - 40 ATTACHED TCBS - 1 QUEUED RRSWKS-
0
DFS000I APPLID=APPL8 GRSNAME= STATUS=DISABLED
DFS000I TCPIP_GENIMSID= STATUS=DISABLED
DFS000I LINE ACTIVE-IN - 1 ACTIV-OUT - 0
DFS000I NODE ACTIVE-IN - 0 ACTIV-OUT - 0
DFS000I LINK ACTIVE-IN - 0 ACTIV-OUT - 0
DFS000I *09039/142037* IMS1
```

#### **Example 4 for /DISPLAY ACTIVE DC command showing TCP/IP generic resources**

Two examples of the /DISPLAY ACT DC command are shown here. The first example is issued on an IMS system within a TCP/IP generic resource group. The second example is issued on the remote partner IMS system that is connects to the TCP/IP generic resource group.

Entry ET in the TCP/IP generic resource group:

```
/DISPLAY ACTIVE DC
```

Response ET in the TCP/IP generic resource group:

```
VTAM STATUS AND ACTIVE DC COUNTS
VTAM ACB OPEN -LOGONS ENABLED
IMSLU=N/A.N/A APPC STATUS=DISABLED TIMEOUT= 0 MAXC= 5000
OTMA GROUP=N/A STATUS=NOTACTIVE
APPC/OTMA SHARED QUEUE STATUS - LOCAL=INACTIVE GLOBAL=INACTIVE
APPC/OTMA SHARED QUEUES LOGGING=N
APPC/OTMA RRS MAX TCBS - 40 ATTACHED TCBS - 1 QUEUED RRSWKS- 0
APPLID=L6APPL3 GRSNAME= STATUS=DISABLED
TCPIP_GENIMSID=IMS STATUS=ACTIVE
LINE ACTIVE-IN - 1 ACTIV-OUT - 0
NODE ACTIVE-IN - 0 ACTIV-OUT - 0
LINK ACTIVE-IN - 0 ACTIV-OUT - 0
*11130/230804*
```

Entry ET in the partner of a TCP/IP generic resource group:

```
/DISPLAY ACTIVE DC
```

Response ET in the partner of a TCP/IP generic resource group:

```
VTAM STATUS AND ACTIVE DC COUNTS
VTAM ACB OPEN -LOGONS ENABLED
IMSLU=N/A.N/A APPC STATUS=DISABLED TIMEOUT= 0 MAXC= 5000
OTMA GROUP=N/A STATUS=NOTACTIVE APPC/OTMA SHARED QUEUE STATUS - LOCAL=INACTIVE
GLOBAL=INACTIVE
APPC/OTMA SHARED QUEUES LOGGING=N
APPC/OTMA RRS MAX TCBS - 40 ATTACHED TCBS - 1 QUEUED RRSWKS- 0
APPLID=L6APPL1 GRSNAME= STATUS=DISABLED
TCPIP_GENIMSID= STATUS=DISABLED
LINE ACTIVE-IN - 1 ACTIV-OUT - 0
NODE ACTIVE-IN - 0 ACTIV-OUT - 0
LINK ACTIVE-IN - 0 ACTIV-OUT - 0
*11130/231519*
```

#### **Example 5 for /DISPLAY ACTIVE DC command showing TCP/IP generic resources with XRF**

The following example shows the output of the **/DISPLAY ACT DC** command for a system that is participating in both an XRF complex and in an MSC TCP/IP generic resource group.

In the example, the use of XRF is indicated by the presence of the USERVAR field and the DFSRSENM field. The use of TCP/IP generic resources is indicated by a non-blank value on the TCPIP\_GENIMSID field and a status of ACTIVE.

Entry ET in the TCP/IP generic resource group:

```
/DISPLAY ACTIVE DC
```

Response ET in the TCP/IP generic resource group:

```
DFS000I  VTAM STATUS AND ACTIVE DC COUNTS
DFS000I  VTAM ACB OPEN          -LOGONS ENABLED
DFS000I  IMSLU=N/A.N/A          APPC STATUS=DISABLED  TIMEOUT=  0  MAXC= 5000
DFS000I  OTMA GROUP=N/A        STATUS=NOTACTIVE
DFS000I  APPC/OTMA SHARED QUEUE STATUS - LOCAL=UNSUPPORTED  GLOBAL=INACTIVE
DFS000I  APPC/OTMA SHARED QUEUES LOGGING=N
DFS000I  APPC/OTMA RRS MAX TCBS - 40 ATTACHED TCBS -  2 QUEUED
RRSWKS-  0
DFS000I  APPLID=APPL8          USERVAR=IMS1
DFS000I  TCPIP_GENIMSID=IMS    STATUS=ACTIVE
DFS000I  LINE ACTIVE-IN -     1 ACTIV-OUT -     0
DFS000I  NODE ACTIVE-IN -     0 ACTIV-OUT -     0
DFS000I  LINK ACTIVE-IN -     0 ACTIV-OUT -     0
DFS000I  *11201/163416* DFSRSENM ACTIVE
```

## Examples of /DISPLAY ACTIVE REG

### Example 1 for /DISPLAY ACTIVE REG command

Entry ET:

```
/DISPLAY ACTIVE REG
```

Response ET:

| REGID          | JOBNAME | TYPE | TRAN/STEP | PROGRAM  | STATUS   | CLASS      | IMS1 |
|----------------|---------|------|-----------|----------|----------|------------|------|
| 2              | MPPI3   | TP   | SHF1      | PMVAPZ12 | WAIT-QSC | 1, 2, 3, 4 |      |
| 1              | MPPI2   | TP   | NQF1      | PMVAPZ12 | WAIT-QSC | 1, 2, 3, 4 |      |
|                | JMPRGN  | JMP  | NONE      | IMS1     |          |            |      |
| 3              | BMPI4   | BMP  |           | PMVAPZ12 | WAIT-QSC | IMS1       |      |
|                | JBPRGN  | JBP  | NONE      | IMS1     |          |            |      |
|                | FPRGN   | FP   | NONE      | IMS1     |          |            |      |
|                | DBTRGN  | DBT  | NONE      | IMS1     |          |            |      |
|                | DBRISAK | DBRC |           |          | IMS1     |            |      |
|                | DLIISAK | DLS  | IMS1      |          |          |            |      |
| *08030/132621* |         |      | IMS1      |          |          |            |      |

Explanation: The status of MPPI2, MPPI3, and BMPI4 transactions are shown as WAIT-QSC, which indicates that the database that these transactions are trying to access are in quiesce state and that the transactions are waiting for the **UPDATE STOP(QUIESCE)** command to be issued to release the quiesce.

### Example 2 for /DISPLAY ACTIVE REG command

Entry ET:

```
/DISPLAY ACTIVE REG
```

Response ET:

| REGID | JOBNAME  | TYPE  | TRAN/STEP | PROGRAM | STATUS        | CLASS |
|-------|----------|-------|-----------|---------|---------------|-------|
| 1     | MPP1A    | TP    | APOL11    | APOL1   | WAIT-CALLOUT  | 1     |
|       |          | TMEM: | HWS1      |         | TPIPE: TPIPE1 |       |
|       | JMPRGN   | JMP   | NONE      |         |               |       |
|       | JBPRGN   | JBP   | NONE      |         |               |       |
|       | BATCHREG | BMP   | NONE      |         |               |       |
|       | FPRGN    | FP    | NONE      |         |               |       |

```

DBTRGN   DBT   NONE
DBRZCSAJ DBRC
DLIZCSAJ DLS
*08235/173441*

```

Explanation: Message processing program APOL1 is processing transaction APOL11, which is waiting for a response to a synchronous callout request (WAIT-CALLOUT) from transaction pipe TPIPE1.

**Example 3 for /DISPLAY ACTIVE REG command**

Entry ET:

```
/DISPLAY ACTIVE REG
```

Response ET:

```

REGID JOBNAME  TYPE  TRAN/STEP  PROGRAM  STATUS CLASS IMS1
      JMPRGN   JMP   NONE     IMS1
1  IMSMPPA   TPI   APOL11  IMS1   APOL1 WAIT-RRS/PC 1,2,3,4
URID: C2D6B6917DE820000000000001010000 ORIGIN: IMS1
2  IMSMPPB   TPI   APOL12  IMS1   APOL1 TERM-WAIT RRS 1,2,3,4
URID: C2D6B6917DE830000000000001010000 ORIGIN: IMS1
3  IMSMPPB   TPI   APOL13  IMS1   APOL1 WAIT-XCF 1,2,3,4
TMEM: HWS1          TPIPE: CLIENT01 ORIGIN: IMS1
4  IMSMPPB   TPI   APOL14  IMS1   APOL1 TERM-WAIT XCF 1,2,3,4
LUNAME: IMSNETWK.LU62IMS1 ORIGIN: IMS1
5  IFP2A     FPM   TXCDRN01 DDLTRN01 WAIT-RRS/PC
URID: D02C7FD77E316000000000001030000 ORIGIN: IMS1
      JBPRGN   JBP   NONE     IMS1
      BATCHREG BMP   NONE     IMS1
      FPRGN    FP    NONE     IMS1
      DBTRGN   DBT   NONE     IMS1
      DBRICTAB DBRC  IMS1
      DLISDEP  DLS   IMS1
*16019/150537*

```

**Example 4 for /DISPLAY ACTIVE REG command**

Entry ET:

```
/DIS ACTIVE REG
```

Response ET:

```

REGID JOBNAME  TYPE  TRAN/STEP  PROGRAM  STATUS        CLASS
1  MPP1A     TP   APOL11    APOL1    WAIT-CALLOUT 1
      TRAN:SKS1
      END TIME: 2010.172 12:45:04
      JMPRGN   JMP   NONE
      JBPRGN   JBP   NONE
      BATCHREG BMP   NONE
      FPRGN    FP    NONE
      DBTRGN   DBT   NONE
      DBRZCSAJ DBRC
      DLIZCSAJ DLS
*10172/120101*
*

```

The APOL11 transaction is in the WAIT-CALLOUT state while it waits for a response to a synchronous program switch request. SKS1 is the transaction name that was requested in the ICAL call. The timeout value of the ICAL call was used to calculate the value of the END TIME field.

**Related reference**

[“Command keywords and their synonyms” on page 59](#)

All IMS command keywords and their synonyms, as well as keywords supported by the OM API, are listed. The list covers command keywords for the OM command processing clients such as IMS, ODBM, IMSCON, and RM.

## /DISPLAY AFFIN command

Use the **/DISPLAY AFFIN** command to display the current link or node affinities that an IMS subsystem has within a TCP/IP or VTAM generic resource group.

Subsections:

- [“Environment” on page 529](#)
- [“Syntax” on page 529](#)
- [“Keywords” on page 529](#)
- [“Usage notes” on page 530](#)
- [“Equivalent IMS type-2 commands” on page 530](#)
- [“Examples” on page 530](#)

### Environment

The following table lists the environments (DB/DC, DBCTL, and DCCTL) in which you can use the command and keywords.

Table 271. Valid environments for the /DISPLAY AFFIN command and keywords

| Command / Keywords | DB/DC | DBCTL | DCCTL |
|--------------------|-------|-------|-------|
| <b>/DISPLAY</b>    | X     | X     | X     |
| AFFIN              | X     |       | X     |
| NODE               | X     |       | X     |
| LINK               | X     |       | X     |

### Syntax

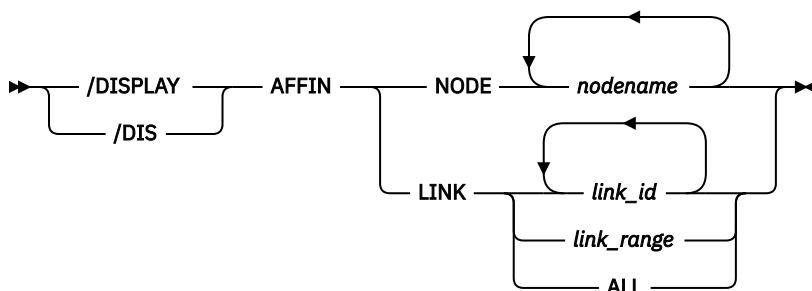

### Keywords

The following keywords are valid for the **/DISPLAY AFFIN** command:

#### NODE

Specify one or multiple nodes. You cannot specify generic names such as *nodename\** or ALL.

#### LINK

Specify one or multiple links, a range of links, or ALL. You must specify *link\_range* in the form of *link\_a-link\_b*; for example, 1-3.

## Usage notes

This command is valid only when you use TCP/IP or VTAM generic resources.

## Equivalent IMS type-2 commands

The following table shows variations of the **/DISPLAY AFFIN** command and the IMS type-2 commands that perform similar functions.

Table 272. Type-2 equivalents for the **/DISPLAY AFFIN** command

| Task   | <b>/DISPLAY AFFIN</b> command           | Similar IMS type-2 command                     |
|--|---|--|
| Displays TCP/IP generic resource affinities. | <b>/DISPLAY AFFIN LINK</b> <i>links</i> | QUERY MSLINK NAME(linkname   *)<br>SHOW(AFFIN) |
| Displays VTAM generic resource affinities.   | <b>/DISPLAY AFFIN NODE</b> <i>node</i>  | QUERY NODE SHOW(AFFIN)                         |

## Examples

The following are examples of the **/DISPLAY AFFIN** command.

### Example 1 for **/DISPLAY AFFIN** command

Entry ET:

```
/DISPLAY AFFIN NODE NDSL2A1
```

Response ET:

```
NODE      APPLID
NDSL2A1  APPL9
*97098/162106*
```

Explanation: The node has an affinity for APPL ID APPL9.

### Example 2 for **/DISPLAY AFFIN** command

Entry ET:

```
/DISPLAY AFFIN NODE LU37722
```

Response ET:

```
NODE      APPLID
LU37722  N/A
*97098/162156*
```

Explanation: The node has no affinities.

### Example 3 for **/DISPLAY AFFIN** command

Entry ET:

```
/DISPLAY AFFIN LINK 22
```

Response ET:

```
DFS000I  LINK LINKNAME  NODE  APPLID
DFS000I  22  LNK12T01      IMS1
```

Explanation: Link 22 has affinity with the current IMS system under the TCP/IP generic resource ID of IMS1.

#### **Example 4 for /DISPLAY AFFIN command**

Entry ET:

```
/DISPLAY AFFIN LINK ALL
```

Response ET:

| DFS000I | LINK | LINKNAME | NODE    | APPLID |
|---------|------|----------|---------|--------|
| DFS000I | 1    | LNK32V01 | L6APPL1 | N/A    |
| DFS000I | 2    | LNK32V02 | L6APPL1 | N/A    |
| DFS000I | 3    | LNK32V03 | L6APPL1 | N/A    |
| DFS000I | 4    | LNK31V01 | L6APPL3 | APPL7  |
| DFS000I | 5    | LNK31V05 | L6APPL3 | APPL7  |
| DFS000I | 6    | LNK32V05 | L6APPL1 | N/A    |
| DFS000I | 7    | LNK31T01 |         | N/A    |
| DFS000I | 22   | LNK32T01 |         | IMS1   |
| DFS000I | 23   | LNK33T01 |         | IMS1   |

Explanation: Links 4 and 5 to IMS node L6APPL3 have affinity for APPL7 in the IMSplex. Links 1, 2, 3, and 6 are VTAM links to IMS node L6APPL1 and have no affinity. Link 7 is not a VTAM link.

Links 22 and 23 are MSC TCP/IP links that have affinity to the current IMS system within the IMS1 TCP/IP generic resource group.

#### **Related reference**

[QUERY NODE command \(Commands\)](#)

## **/DISPLAY AOITKN command**

Use the /DISPLAY AOITKN command to display all Automated Operator Interface (AOI) tokens in the system.

Subsections:

- [“Environment” on page 531](#)
- [“Syntax” on page 531](#)
- [“Usage notes” on page 531](#)
- [“Output fields” on page 532](#)
- [“Examples” on page 532](#)

### **Environment**

The /DISPLAY AOITKN command is valid in DB/DC, DBCTL, and DCCTL environments.

### **Syntax**

```
▶▶ /DISPLAY AOITKN ◀◀  
  /DIS
```

### **Usage notes**

If QCT=0 and W-REGID=NONE, then the AOI token is deleted at the next checkpoint.

## Output fields

The following output fields are displayed for each AOI token:

### AOITKN

AOI token name.

### ENQCT

Total number of messages enqueued. In a shared-queues environment, only shows messages enqueued for the local subsystem.

### QCT

Number of messages currently queued to the token and not yet retrieved by the AO application. In a shared-queues environment, only shows messages enqueued for the local subsystem.

### SEGS

Number of segments in messages queued (QCT) to the AOI token.

### W-REGID

The region IDs of AO applications that issued a GMSG call with the WAITAOI subfunction specified. This AO application is in a wait state, since there are currently no messages for it to retrieve.

## Examples

Entry ET:

```
/DISPLAY AOITKN
```

Response ET:

| AOITOKEN       | ENQCT      | QCT        | SEGS       | W-REGID |
|----------------|------------|------------|------------|---------|
| AOITOKN1       | 4          | 2          | 12         | NONE    |
| AOITOKN2       | 0          | 0          | 0          | 2,4     |
| AOITOKN3       | 1          | 0          | 0          | NONE    |
| AOITOKN4       | 1000000000 | 1000000000 | 2147483647 | NONE    |
| *92280/095345* |            |            |            |         |

## /DISPLAY APPC command

Use the **/DISPLAY APPC** command to display inquiries about LU 6.2 related activities, including the current outbound LU if it is different from the base LU.

Subsections:

- [“Environment” on page 532](#)
- [“Syntax” on page 532](#)
- [“Output fields” on page 533](#)
- [“Examples” on page 534](#)

## Environment

The **/DISPLAY APPC** command is valid in DB/DC and DCCTL environments.

## Syntax

```
▶▶ /DISPLAY APPC ▶▶  
  /DIS
```



## Output fields

The following output fields are displayed for the **/DISPLAY APPC** command:

### IMSLU

The IMSLU is a base IMS LU name. This LU is always a network-qualified LU name. It is displayed as N/A. N/A if IMS is not connected to APPC/MVS. For example, if status is DISABLED, FAILED, or STARTING, N/A. N/A applies. For the CANCEL status, the field can contain either the LU name or N/A. N/A.

### #APPC-CONV

LU 6.2 inbound and outbound conversation count.

### SECURITY

RACF security level, which is one of the following:

- CHECK
- FULL
- NONE
- PROFILE

### STATUS

The current APPC connection status. The possible values for APPC connection status are:

#### CANCEL

Shown after the **/STOP APPC CANCEL** command.

#### DISABLED

Shown when APPC/IMS is not identified or connected to APPC/MVS.

#### ENABLED

Shown after successful **/START APPC** command completion.

#### FAILED

Shown after unsuccessful **/START APPC** command.

#### OUTBOUND

Shown on the XRF alternate system as it tracks the active. It is also shown on the active if IMS is unable to initiate normal APPC processing. For example, the **/START APPC** command can be reissued to attempt APPC enablement.

#### PURGING

Shown after the **/PURGE APPC** command.

#### STARTING

Shown after the **/START APPC** is issued and before the status is set to ENABLED or FAILED.

#### STOPPED

Shown after the **/STOP APPC** command.

### DESIRED

Desired APPC connection status. This status is changed by the **/PURGE**, **/START** and **/STOP APPC (CANCEL)** commands. The possible values for desired APPC connection status are:

#### CANCEL

Shown after **/STOP APPC CANCEL**

#### DISABLED

Shown when APPC/IMS is not identified or connected to the APPC/MVS

#### ENABLED

Shown after **/START APPC**

#### OUTBOUND

Shown on the XRF alternate system as it tracks the active

#### PURGING

Shown after **/PURGE APPC**

## STOPPED

Shown after **/STOP APPC**

### GRNAME

The IMS/APPC generic LU name (if VTAM Generic Resources is activated).

### TYPE

BASE for BASE LU or OUTB for OUTBOUND LU.

### Examples

Entry ET:

```
/DISPLAY APPC
```

Response ET:

```
IMSLU      #APPC-CONV SECURITY STATUS  DESIRED
IMSLUNME   0 FULL      ENABLED  ENABLED
*90347/114253*
```

Entry ET:

```
/DISPLAY APPC
```

Response ET:

```
IMSLU      #APPC-CONV SECURITY STATUS  DESIRED
IMSLUNME   0 FULL      DISABLED  ENABLED
*90347/114253*
```

Entry ET:  
/DISPLAY APPC

Response ET:

```
IMSLU      #APPC-CONV SECURITY STATUS  DESIRED
SYS1.IMSLUNME 0 FULL      STOPPED  STOPPED
*92232/114253*
```

## **/DISPLAY AREA** command

Use the **/DISPLAY AREA** command to display data sets, status conditions, control intervals, and databases associated with an area.

Subsections:

- [“Environment” on page 534](#)
- [“Syntax” on page 535](#)
- [“Keywords and reserved parameters” on page 535](#)
- [“Usage notes” on page 535](#)
- [“Equivalent IMS type-2 commands” on page 536](#)
- [“Output fields” on page 536](#)
- [“Examples” on page 538](#)

### Environment

The **/DISPLAY AREA** command is valid in DB/DC and DBCTL environments.

## Syntax

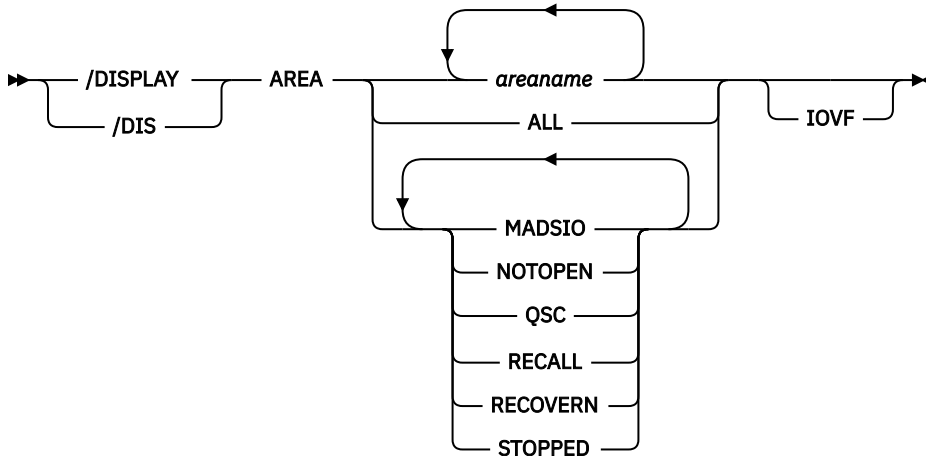

## Keywords and reserved parameters

The following keywords can be specified for the **/DISPLAY AREA** command:

### IOVF

Displays the independent overflow area statistics.

When the ALL parameter is used with the IOVF keyword (for example, **/DIS AREA ALL IOVF**), performance can be affected depending on the number and size of areas involved. If large areas, large numbers of areas, or both are involved, the control region can appear to be stopped while processing this command.

Areas are selected for display based on the attributes specified. For example, **/DISPLAY AREA STOPPED** only displays the areas that are currently stopped. The attribute display format is the same as the standard AREA display. Attributes generally correspond to the conditions displayed for areas. Any exceptions are flagged in the following list.

The attributes are reserved parameters for the **/DISPLAY AREA** command and cannot be used to name areas. The following list describes the attributes that can be used with the AREA keyword:

### MADSIO

Displays the areas that are currently in a long busy condition or are in long busy recovery mode.

### NOTOPEN

Displays the areas that have yet to be opened.

### QSC

Displays the Fast Path DEDB areas that are currently quiesced by a previous **UPDATE DB START(QUIESCE)** or **UPDATE AREA START(QUIESCE)** command.

### RECALL

Displays the areas that are in recall.

### RECOVERN

Displays the areas that need recovery. This parameter corresponds to the area condition RECOVERY-NEEDED.

### STOPPED

Displays the areas that are currently stopped.

## Usage notes

If an IMS Fast Path utility is active when the **/DISPLAY AREA** command is issued, the following output line is displayed:

```
UTILITY XXXX  PVTOT#  YY  PVTAVL#  ZZ  IMSID:SSSS  TTTT
```

or

```
UTILITY: XXXX  IMSID:SSSS
```

The output values represent:

- XXXX - the active utility name or VSO function
- YY - the total number of private buffers available to the utility
- ZZ - the number of unused private buffers available to the utility
- SSSS - the IMSID of the IMS system on which the utility is active
- TTTT - the IMSID of the IMS system on which the display was issued

The following IMS Fast Path utilities, VSO functions, and IBM DBTOOL utility can be displayed:

- DA00 (DBFUDA00, DEDB Alter utility)
- HSSP (High Speed Sequential Processing utility)
- HSRE (DBFUHDR0, High Speed Reorganization utility)
- MDL0 (DBFUMDL0, SDEP Delete utility)
- MSC0 (DBFUMSC0, SDEP Scan utility)
- MRI0 (DBFUMRI0, DEDB Create utility)
- MMH0 (DBFUMMH0, DEDB Compare utility)
- PRLD (VSO Preload is active)
- TOOL (an IBM DBTOOL Online utility)

## Equivalent IMS type-2 commands

The following table shows variations of the **/DISPLAY AREA** command and the IMS type-2 commands that perform similar functions.

*Table 273. Type-2 equivalents for the /DISPLAY AREA command*

| Task                                | /DISPLAY AREA command | Similar IMS type-2 command |
|-------------------------------------|-----------------------|----------------------------|
| Displays information about an area. | /DISPLAY AREA         | QUERY AREA                 |

## Output fields

The following output fields are displayed for the **/DISPLAY AREA** command:

### AREANAME

Name of the Fast Path DEDB area.

### DDNAME

Names of the data sets that contain that area.

### CONDITIONS

Status conditions associated with the area or ADS.

Status conditions associated with the area include:

### IC

HSSP image copy is currently active on the area.

**MADSIO**

The area is currently in a long busy condition or long busy recovery mode.

**NOTOPEN**

The area has yet to be opened. This will be done when first call is issued to the area.

**RECALL**

Area is in recall.

**RECOVERY-NEEDED**

The area has been marked RECOVERY-NEEDED. The Database Recovery utility needs to be run to restore this area.

**STOPPED**

The area is in STOPPED status. All access to it is prohibited. This can be changed with the **/START** command.

**VIR**

The area is a VSO area.

**PREO**

The area is defined to be preopened during IMS initialization.

**PREL**

The area is defined to be preloaded during IMS initialization.

**QUIESCED**

The Fast Path DEDB area named on the command is currently quiesced by a previous **UPDATE DB START (QUIESCE)** or **UPDATE AREA START (QUIESCE)** command.

**QUIESCING**

The Fast Path DEDB area named on the command is currently undergoing quiesce by a previous **UPDATE DB START (QUIESCE)** or **UPDATE AREA START (QUIESCE)** command.

Status conditions associated with the ADS include the following:

**COPY-PHASE**

The CREATE utility is currently in the COPY phase on this ADS. The CREATE utility must complete before anything can be done with this ADS.

**FORMAT-PHASE**

The CREATE utility is currently in the FORMAT phase on this ADS. The CREATE utility must complete before anything can be done with this ADS.

**PRE-OPEN FAILED**

XRF PREOPEN was not successful for this ADS.

**RECALL**

Area is in Recall.

**SEVERE-ERROR**

This ADS has had a severe I/O error (write error to second CI, in which Fast Path keeps its control information).

**UNAVAILABLE**

This ADS has been marked unavailable, probably because of I/O errors. (EQE REMAIN = 0).

**EQECT**

Specifies the count of I/O errors for the area.

**TOTAL SEQ DEPENDENT**

Total control intervals defined for sequential dependent space.

**UNUSED SEQ DEPENDENT**

Unused control intervals for sequential dependent space.

**TOTAL DIRECT ADDRESSABLE**

Total control intervals defined for direct addressable space.

**UNUSED DIRECT ADDRESSABLE**

Unused control intervals for direct addressable space.

**DBNAME**

Database name.

**EEQECT**

Count of write error EEQE for this area.

**IOVF**

Independent overflow area statistics.

These statistics are only displayed if IOVF is specified on the **/DIS AREA** command (**/DIS AREA ALL IOVF** or **/DIS AREA areaname IOVF**). If the IOVF parameter is not specified on the **/DIS AREA** command, N/A appears in the display output.

**Examples**

The following are examples of the **/DISPLAY AREA** command.

**Example 1 for /DISPLAY AREA command**

Entry ET:

```
/DIS AREA db21ar1 db21ar3 db21ar6 IOVF
```

Response ET:

| AREANAME | EQECT  | TOTAL UNUSED  | TOTAL UNUSED    | DBNAME | EEQECT         | CONDITIONS          |
|----------|--------|---------------|-----------------|--------|----------------|---------------------|
| DDNAME   | REMAIN | SEQ DEPENDENT | DIR ADDRESSABLE |        |                |                     |
| DB21AR1  | N/A    | 13            | 11              | 74     | 74-CI DEDBJN21 | 999 VIR, PREO, PREL |
| DB21AR1  | 10     | N/A           | N/A             | N/A    | N/A            | N/A                 |
| DB21AR1B | 10     | N/A           | N/A             | N/A    | N/A            | N/A                 |
| DB21AR1C | 10     | N/A           | N/A             | N/A    | N/A            | N/A                 |
| DB21AR3  | N/A    | 13            | 11              | 74     | 56-CI DEDBJN21 | PREO                |
| DB21AR3  | 10     | N/A           | N/A             | N/A    | N/A            | N/A                 |
| DB21AR3B | 10     | N/A           | N/A             | N/A    | N/A            | N/A                 |
| DB21AR6  | N/A    | 17            | 15              | 74     | 56-CI DEDBJN21 |                     |
| DB21AR6  | 10     | N/A           | N/A             | N/A    | N/A            | N/A                 |

\*93076/173254\*

Explanation: DIR ADDRESSABLE means Independent Overflow part.

**Example 2 for /DISPLAY AREA command**

Entry ET:

```
/DIS AREA ALL
```

Response ET:

| AREANAME | EQECT  | TOTAL UNUSED  | TOTAL UNUSED    | DBNAME  | EEQECT | CONDITIONS                   |
|----------|--------|---------------|-----------------|---------|--------|------------------------------|
| DDNAME   | REMAIN | SEQ DEPENDENT | DIR ADDRESSABLE |         |        |                              |
| DB21AR0  | N/A    | 17            | 15              | 74      | N/A    | DEDBJN21 999 VIR, PREO, PREL |
| DB21AR0  | 10     | N/A           | N/A             | N/A     | N/A    | N/A                          |
| DB21AR1  | N/A    | 13            | 11              | 74      | N/A    | DEDBJN21 VIR, PREO           |
| DB21AR1  | 10     | N/A           | N/A             | N/A     | N/A    | N/A                          |
| DB21AR1B | 10     | N/A           | N/A             | N/A     | N/A    | N/A                          |
| DB21AR1C | 10     | N/A           | N/A             | N/A     | N/A    | N/A                          |
| DB21AR10 | N/A    | 17            | 15              | 74      | N/A    | DEDBJN21 VIR, PREO, PREL     |
| DB21AR10 | 10     | N/A           | N/A             | N/A     | N/A    | N/A                          |
| DB21AR11 | N/A    | 133           | 131             | 74      | N/A    | DEDBJN21 VIR                 |
| DB21AR11 | 10     | N/A           | N/A             | N/A     | N/A    | N/A                          |
| DB21AR2  | N/A    | 19            | 17              | 74      | 0-UW   | DEDBJN21 VIR, PREO, PREL     |
| UTILITY: | HSRE   | PVTTOT#       | 45              | PVTAVL# | 15     |                              |
| DB21AR2  | 10     | N/A           | N/A             | N/A     | N/A    | N/A                          |
| DB21AR3  | N/A    | 13            | 11              | 74      | N/A    | DEDBJN21 PREO                |
| DB21AR3  | 10     | N/A           | N/A             | N/A     | N/A    | N/A                          |
| DB21AR3B | 10     | N/A           | N/A             | N/A     | N/A    | N/A                          |
| DB21AR4  | N/A    | N/A           | N/A             | N/A     | N/A    | DEDBJN21 STOPPED, NOTOPEN    |
| DB21AR5  | N/A    | N/A           | N/A             | N/A     | N/A    | DEDBJN21 STOPPED, NOTOPEN    |
| DB21AR6  | N/A    | N/A           | N/A             | N/A     | N/A    | DEDBJN21 STOPPED, NOTOPEN    |

|                |     |     |     |     |     |          |         |
|----------------|-----|-----|-----|-----|-----|----------|---------|
| DB21AR7        | N/A | N/A | N/A | N/A | N/A | DEDBJN21 | NOTOPEN |
| DB21AR8        | N/A | N/A | N/A | N/A | N/A | DEDBJN21 | NOTOPEN |
| DB21AR9        | N/A | N/A | N/A | N/A | N/A | DEDBJN21 | NOTOPEN |
| *93076/173254* |     |     |     |     |     |          |         |

Explanation: DIR ADDRESSABLE means Independent Overflow part.

**Example 3 for /DISPLAY AREA command**

Entry ET:

```
/DIS AREA db11ar4
```

Response ET:

| AREANAME<br>DDNAME | EQECT<br>REMAIN | TOTAL<br>SEQ | UNUSED<br>DEPENDENT | TOTAL<br>DIR | UNUSED<br>ADDRESSABLE | DBNAME   | EQECT | CONDITIONS                    |
|--------------------|-----------------|--------------|---------------------|--------------|-----------------------|----------|-------|-------------------------------|
| DB21AR4            | N/A             | N/A          | N/A                 | N/A          | N/A                   | DEDBJN21 | 999   | STOPPED, NOTOPEN,<br>RECOVERY |
| *97136/173254*     |                 |              |                     |              |                       |          |       |                               |

Explanation: RECOVERY means this Fast Path area is undergoing recovery with the Online Recovery Service.

**Example 4 for /DISPLAY AREA command**

Entry ET:

```
/DIS AREA DB21AR0
```

Response ET:

| DFS000I<br>SYS3 | AREANAME<br>DDNAME | EQECT<br>REMAIN | TOTAL<br>SEQ | UNUSED<br>DEPENDENT | TOTAL<br>DIR | UNUSED<br>ADDRESSABLE | DBNAME      | EEQECT | CONDITIONS      |
|-----------------|--------------------|-----------------|--------------|---------------------|--------------|-----------------------|-------------|--------|-----------------|
| DFS000I<br>SYS3 | DB21AR0            | N/A             | 29           | 28                  | 74           | 0-UW                  | DEDBJN21    | 0      | VIR, PRE0, PREL |
| DFS000I<br>SYS3 | UTILITY:           | HSSP            | PVTTOT#      | 45                  | PVTAVL#      | 30                    | IMSID: IMS2 |        |                 |
| DFS000I<br>SYS3 | DB21AR01           | 10              | N/A          | N/A                 | N/A          | N/A                   | N/A         |        |                 |
| DFS000I<br>SYS3 | DB21AR02           | 10              | N/A          | N/A                 | N/A          | N/A                   | N/A         |        |                 |
| DFS000I<br>SYS3 | DB21AR03           | 10              | N/A          | N/A                 | N/A          | N/A                   | N/A         |        |                 |

Explanation: The IMS Fast Path utility, HSSP, is active on IMSID=IMS2.

**Example 5 for /DISPLAY AREA command**

Entry ET:

```
/DIS AREA QSC
```

Response ET:

| AREANAME<br>DDNAME | EQECT<br>REMAIN | TOTAL<br>SEQ | UNUSED<br>DEPENDENT | TOTAL<br>DIR | UNUSED<br>ADDRESSABLE | DBNAME  | EEQECT | CONDITIONS |
|--------------------|-----------------|--------------|---------------------|--------------|-----------------------|---------|--------|------------|
| AXYZ01             | N/A             | N/A          | N/A                 | N/A          | N/A                   | FPDBXYZ | 0      | QUIESCED   |

Explanation: This is an example of displaying databases that have the status of quiesced.

**Related concepts**

[DEDB area design guidelines \(Database Administration\)](#)

## Related reference

[QUERY AREA command \(Commands\)](#)

## **/DISPLAY ASMT command**

---

Use the **/DISPLAY ASMT** command to display resource assignments.

Subsections:

- [“Environment” on page 540](#)
- [“Syntax” on page 540](#)
- [“Keywords” on page 541](#)
- [“Equivalent IMS type-2 commands” on page 542](#)
- [“Examples” on page 543](#)

### **Environment**

The following table lists the environments (DB/DC, DBCTL, and DCCTL) in which you can use the command and keywords.

*Table 274. Valid environments for the /DISPLAY ASMT command and keywords*

| <b>Command / Keywords</b> | <b>DB/DC</b> | <b>DBCTL</b> | <b>DCCTL</b> |
|---------------------------|--------------|--------------|--------------|
| <b>/DISPLAY</b>           | X            | X            | X            |
| ASMT                      | X            |              | X            |
| LINE                      | X            |              | X            |
| LINK                      | X            |              | X            |
| LTERM                     | X            |              | X            |
| MSNAME                    | X            |              | X            |
| MSPLINK                   | X            |              | X            |
| NODE                      | X            |              | X            |
| SYSID                     | X            |              | X            |
| USER                      | X            |              | X            |

### **Syntax**



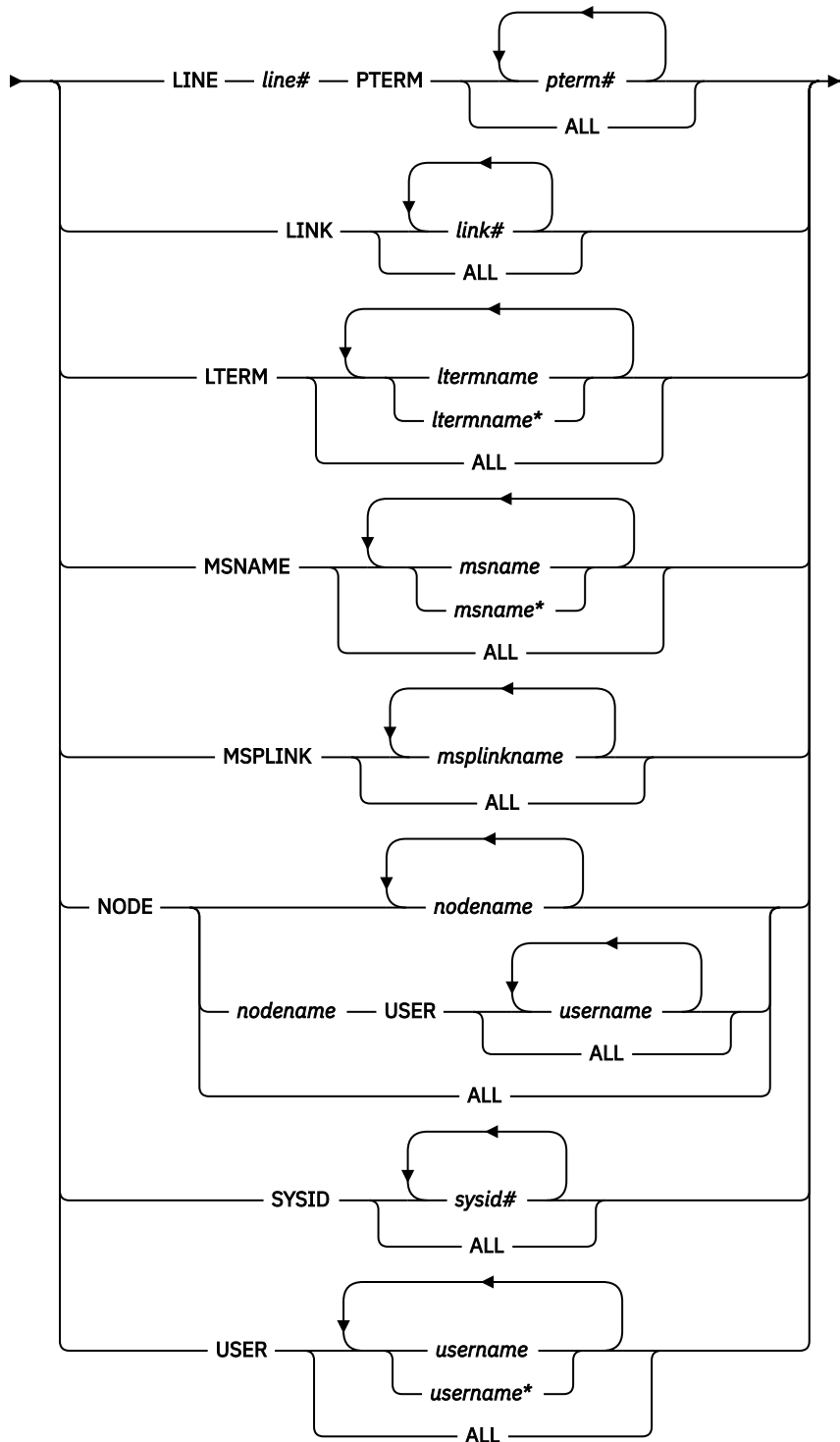

## Keywords

The following keywords are valid for the **/DISPLAY ASMT** command:

### LINE PTERM

The logical terminal names associated with the specified line and physical terminal.

**LINK**

The physical link, SYSIDs, and logical link paths assigned to the specified logical link.

**LTERM**

The communication line and physical terminal or node and component associated with the specified logical terminal name. When using ISC or a dynamic terminal, the displayed output for a logical terminal assigned to the VTAM pool shows the assigned node, if any, and the user name. The LTERM parameter can be generic.

**MSNAME**

The physical link and logical link assigned to the specified logical link path.

**MSPLINK**

The type, address, and logical link associated with the specified physical link.

For MSC with TCP/IP or VTAM, MSPLINK also displays the maximum number of allowed sessions and the identifier used by the remote IMS system. For TCP/IP physical links, the command output displays the IMS ID of the remote IMS system. For VTAM physical links, the output displays the VTAM node name of the remote IMS system.

If logons are stopped for a physical link that is used for MSC TCP/IP generic resources, the status of the link displays as PSTOPGEN.

**NODE**

The logical terminal names associated with the specified node. When using ISC, the displayed output shows at least one line of information for each half-session of the node, shows whether the half-session is active, and shows whether LTERMs are assigned. If the half-session is active, the user identifier is displayed. If no LTERMs are assigned, NONE is indicated. The USER keyword is valid for ISC nodes and non-ISC nodes with signed-on users. The NODE parameter can be generic.

**Restrictions for using NODE and USER parameters together:**

- Commands with the NODE USER keyword pair are valid only if:
  - The USER is signed on to the NODE
  - In an ISC environment, the USER is allocated to the NODE
  - The nodes and users exist
- **/DISPLAY ASMT** commands with NODE USER keyword pair are valid for ISC and non-ISC nodes and users.

**SYSID**

The physical link, logical link, and logical link path assignments associated with the specified system identification.

**USER**

All the USER structures and USERIDs that match the parameter specified. These are the following:

- The USER field shows the USER structure name. N/A appears for all static USERIDs signed on to static nodes.
- The USERID field displays the RACF USERID that was used to sign on to the node. N/A appears if a USER structure is not associated with a node. In this case, the USER structure exists to hold status or has messages inserted to it. If no messages or status exist, the USER structure is deleted at the next checkpoint.
- The node name and logical terminal names are displayed if the user is allocated to a node or signed on to a node.
- For ISC sessions, the ID field shows the other half session qualifier.

The USER parameter can be generic.

**Equivalent IMS type-2 commands**

The following table shows variations of the **/DISPLAY ASMT** command and the IMS type-2 commands that perform similar functions.

Table 275. Type-2 equivalents for the **/DISPLAY ASMT** command

| <b>Task</b>   | <b>/DISPLAY ASMT command</b>                          | <b>Similar IMS type-2 command</b>                |
|---|---|--|
| Displays input and output components.                         | <code>/DISPLAY ASMT LTERM <i>ltermname</i></code>     | QUERY LTERM SHOW(COMPONENT)                      |
| Displays the node associated with the lterm.                  | <code>/DISPLAY ASMT LTERM <i>ltermname</i></code>     | QUERY LTERM SHOW(NODE)                           |
| Displays the user associated with the lterm.                  | <code>/DISPLAY ASMT LTERM <i>ltermname</i></code>     | QUERY LTERM SHOW(USER)                           |
| Displays the attributes of an MSC logical link                | <code>/DISPLAY ASMT MSPLINK <i>msplinkname</i></code> | QUERY MSLINK SHOW(ALL)                           |
| Displays the attributes of an MSC physical link               | <code>/DISPLAY ASMT MSPLINK <i>msplinkname</i></code> | QUERY MSPLINK SHOW(ALL)                          |
| Displays assigned lterms.                                     | <code>/DISPLAY ASMT NODE <i>node</i></code>           | QUERY NODE SHOW(LTERM)                           |
| Displays the user associated with the node.                   | <code>/DISPLAY ASMT NODE <i>node</i></code>           | QUERY NODE SHOW(USER)                            |
| Displays the other half-session qualifier ID of the ISC node. | <code>/DISPLAY ASMT USER <i>user</i></code>           | QUERY USER SHOW(ID)                              |
| Displays assigned lterms.                                     | <code>/DISPLAY ASMT USER <i>user</i></code>           | QUERY USER SHOW(LTERM)                           |
| Displays the node.  | <code>/DISPLAY ASMT USER <i>user</i></code>           | QUERY USER SHOW(NODE)<br>QUERY USERID SHOW(NODE) |
| Displays the user ID.   | <code>/DISPLAY ASMT USER <i>user</i></code>           | QUERY USER SHOW(USERID)                          |
| Displays the user.  | <code>/DISPLAY ASMT USER <i>user</i></code>           | QUERY USERID SHOW(USER)                          |

### Examples

The following are examples of the **/DISPLAY ASMT** command.

#### Example 1 for **/DISPLAY ASMT** command

Entry ET:

```
/DISPLAY ASMT LINE 2 PTERM ALL
```

Response ET:

```
TERMINAL
 2- 1 IN - L2740S2
    OUT - L2740S1, L2740S2
*90295/130910*
```

Entry ET:

```
/DISPLAY ASMT LINE 4 PTERM 1, 2
```

Response ET:

```
TERMINAL
 4- 1 IN - L2740SM1
    OUT- L2740SM1
```

```
4- 2 IN - L2740SM2
      OUT- L2740SM2
*90295/130328*
```

### Example 2 for /DISPLAY ASMT command

Entry ET:

```
/DISPLAY ASMT LINK ALL
```

Response ET:

```
LINK PLINK   SIDR SIDL MSNAME
  1 BLCB1CTC    1   4 SYSTEM2A
                1   5 SYSTEM2B
                3   6 FRESNO
  2 BLCB2BSC   21  23 BOSTON
                22  24 ALBANY
  3 BLCB1MTM   19  20 TEST1
*90280/072935*
```

### Example 3 for /DISPLAY ASMT command

Entry ET:

```
/DISPLAY ASMT LTERM DIALQ1 INQUIRY1 L2740S1 MASTER WTOR
```

Response ET:

```
LTERM      IN-TERMINAL  OUT-TERMINAL  USER
DIALQ1     11- 1         11- 1
INQUIRY1   5- 1          5- 1
L2740S1    3- 1          3- 1
MASTER     3- 1          3- 1
WTOR       1- SC        1- SC
*90295/130657*
```

Entry ET:

```
/DISPLAY ASMT LTERM L1 L2 L3
```

Response ET:

```
LTERM      IN-TERMINAL  OUT-TERMINAL  USER
L1         14- 1         14- 1
L2         NODEA -1     NODEA -1     A
L3         N/A -1      N/A -1      B
*90231/143059*
```

Entry ET:

```
/DISPLAY ASMT LTERM ALL
```

Response ET:

```
LTERM      IN-TERMINAL  OUT-TERMINAL  USER
CRDPUNCH   14- 1         14- 1
DIALQ1     11- 1         11- 1
DIALQ2     12- 1         12- 1
DIALQ3     13- 1         13- 1
INQUIRY1   5- 1          5- 1
INQUIRY2   6- 1          6- 1
INQUIRY3   7- 1          7- 1
INQUIRY4   8- 1          8- 1
INQUIRY5   9- 1          9- 1
INQUIRY6  10- 1         10- 1
L2740SM1   4- 1          4- 1
L2740SM2   4- 2          4- 2
L2740S1    3- 1          3- 1
L2740S2    2- 1          2- 1
MASTER     3- 1          3- 1
PTPPUNCH   14- 1         14- 1
WS12DS     WS12- 1       WS12- 1
```

WTOR 1- SC 1- SC  
\*90295/160953\*

#### Example 4 for /DISPLAY ASMT command

Entry ET:

```
/DISPLAY ASMT MSNAME ALL
```

Response ET:

| LINK | PLINK    | SIDR | SIDL | MSNAME   | IMS1 |
|------|----------|------|------|----------|------|
|      | N/A      | 32   | 3    | LINK23B4 | IMS1 |
| 10   | PLNK12V  | 20   | 10   | LINK12V1 | IMS1 |
|      | N/A      | 35   | 3    | LINK23U2 | IMS1 |
|      | N/A      | 28   | 3    | ELINK211 | IMS1 |
| 1    | PLNK12V  | 31   | 11   | LINK13B3 | IMS1 |
| 10   | PLNK12V  | 266  | 2036 | LINK13V  | IMS1 |
| 10   | PLNK12V  | 256  | 1012 | LINK12V  | IMS1 |
| 2    | PLNK12C  | 33   | 13   | LINK13C2 | IMS1 |
| 10   | PLNK12V  | 80   | 300  | LINK13X  | IMS1 |
| 11   | PLNK12V  | 40   | 9    | LINK12V2 | IMS1 |
| 3    | PLNK12M  | 34   | 14   | LINK13M2 | IMS1 |
| 12   | PLNK13V  | 38   | 18   | LINK13V2 | IMS1 |
| 7    | N/A      | 43   | 44   | ELINK124 | IMS1 |
|      | N/A      | 36   | 3    | LINK23V1 | IMS1 |
| 1    | PLNK12V  | 21   | 11   | LINK12B1 | IMS1 |
| 1    | PLNK12V  | 22   | 12   | LINK12B2 | IMS1 |
| 10   | PLNK12V  | 90   | 500  | LINK12Y  | IMS1 |
| 5    | N/A      | 26   | 16   | ELINK120 | IMS1 |
| 1    | PLNK12V  | 32   | 12   | LINK13B4 | IMS1 |
|      | N/A      | 8    | 3    | LINK21V3 | IMS1 |
| 6    | N/A      | 51   | 41   | ELINK1MS | IMS1 |
| 3    | PLNK12M  | 24   | 14   | LINK12M1 | IMS1 |
|      | N/A      | 266  | 3    | LINK23V  | IMS1 |
| 4    | N/A      | 35   | 15   | LINK13U2 | IMS1 |
|      | N/A      | 31   | 3    | LINK23B3 | IMS1 |
|      | N/A      | 43   | 3    | ELINK224 | IMS1 |
|      | N/A      | 80   | 3    | LINK23X  | IMS1 |
|      | N/A      | 37   | 3    | LINK23V2 | IMS1 |
| 6    | N/A      | 27   | 17   | ELINK121 | IMS1 |
|      | N/A      | 33   | 3    | LINK23C2 | IMS1 |
| 4    | N/A      | 25   | 15   | LINK12U1 | IMS1 |
|      | N/A      | 34   | 3    | LINK23M2 | IMS1 |
| 5    | N/A      | 29   | 19   | ELINK122 | IMS1 |
|      | N/A      | 29   | 3    | ELINK222 | IMS1 |
| 2    | PLNK12C  | 23   | 13   | LINK12C1 | IMS1 |
| 10   | PLNK12V  | 36   | 16   | LINK13V1 | IMS1 |
| 7    | N/A      | 42   | 45   | ELINK123 | IMS1 |
| 16   | LKV1TSTB | 93   | 3    | PTH3TSTB | IMS1 |

\*97258/170244\*

#### Example 5 for /DISPLAY ASMT command

The following example displays information about MSC physical link assignments. The output is displayed in tabular format. Each logical link assigned to a physical link is displayed on a single row. The attributes of the physical links are displayed in columns.

In the output of the /DISPLAY ASMT MSPLINK command:

##### LINK

The link number of the logical link that is assigned to the physical link.

##### PLINK

The name of the physical link.

##### TYPE

The physical link type.

##### ADDR

The address of the physical link. ADDR applies to VTAM and CTC only.

##### MAXSESS

The maximum number of logical links or sessions that can be assigned to the physical link.

## NODE

The identifier of the remote IMS system.

For VTAM physical links, NODE is the node name of the remote IMS system. For TCP/IP physical links, NODE is the IMSID of the remote IMS system.

Entry ET:

```
/DISPLAY ASMT MSPLINK ALL
```

Response ET:

| DFS000I | LINK | PLINK          | TYPE  | ADDR     | MAXSESS | NODE     |
|---------|------|----------------|-------|----------|---------|----------|
| DFS000I | 3    | PLNK12M        | MTM   | ****     |         |          |
| DFS000I | 9    | PLNK12MA       | MTM   | ****     |         |          |
| DFS000I | 2    | PLNK12C        | CTC   | 0211     |         |          |
| DFS000I | N/A  | PLNK12MU       | MTM   | ****     |         |          |
| DFS000I | N/A  | PLNK12CU       | CTC   | ****     |         |          |
| DFS000I | 1    | PLNK12V        | VTAM  | 00000000 | 3       | L6APPL1  |
| DFS000I | 10   | PLNK12V        | VTAM  | 00000000 | 3       | L6APPL1  |
| DFS000I | 11   | PLNK12V        | VTAM  | 00000000 | 3       | L6APPL1  |
| DFS000I | 28   | PLNK12V        | VTAM  | 00000000 | 3       | L6APPL1  |
| DFS000I | N/A  | PLNK12VU       | VTAM  | ****     | 1       | PZ606099 |
| DFS000I | 12   | PLNK13V        | VTAM  | 00000000 | 5       | APPL7    |
| DFS000I | 13   | PLNKSON1       | VTAM  | 00000000 | 1       | L6APPLU  |
| DFS000I | 14   | PLNKSON2       | VTAM  | 00000000 | 2       | L6APPLV  |
| DFS000I | 15   | PLNKSON3       | VTAM  | 00000000 | 2       | L6APPLW  |
| DFS000I | 16   | PLNK12MB       | MTM   | ****     |         |          |
| DFS000I | 17   | PLNK13MB       | MTM   | ****     |         |          |
| DFS000I | 18   | PLNK12CB       | CTC   | ****     |         |          |
| DFS000I | 19   | PLNK13CB       | CTC   | ****     |         |          |
| DFS000I | 20   | PLNK12VB       | VTAM  | 00000000 | 2       | L6APPL1  |
| DFS000I | 21   | PLNK13VB       | VTAM  | 00000000 | 2       | APPL7    |
| DFS000I | 22   | PLNK12TA       | TCPIP | ****     | 2       | IMS2     |
| DFS000I | 23   | PLNK12TA       | TCPIP | ****     | 2       | IMS2     |
| DFS000I | 24   | PLNK13TA       | TCPIP | ****     | 2       | IMS3     |
| DFS000I |      | *11130/232948* |       |          |         |          |

### Example 6 for /DISPLAY ASMT command

Entry ET:

```
/DISPLAY ASMT NODE NLU1 NLUT65 NLUT6P
```

Response ET:

| NODE   | USER | LTERM          |
|--------|------|----------------|
| NLU1   |      | I/O- L1 , L2   |
| NLUT65 |      | I/O- L3        |
| NLUT6P | A    | I/O- L5 , L6   |
| NLUT6P | N/A  | I/O- NONE      |
| NLUT6P | C    | I/O- L7        |
|        |      | *04008/113126* |

Entry ET:

```
/DISPLAY ASMT NODE NLUT6P USER C
```

Response ET:

| NODE   | USER | LTERM          |
|--------|------|----------------|
| NLUT6P | C    | I/O- L7        |
|        |      | *04008/113126* |

Entry ET:

```
/DISPLAY ASMT NODE ALL
```

Response ET:

| NODE   | USER | LTERM                 |
|--------|------|-----------------------|
| CT3275 |      | I/O- VT3275 , VT3275P |

```

CT3277A      I/O- VT3270A
CT3277B      I/O- VT3270B
CT3277C      I/O- VT3270C
CT3277D      I/O- VT3270P1
CT3277E      I/O- VT3270P2
L3270A       I/O- VT3270L1
L3270B       I/O- VT3270L2
L3284A       I/O- VT3270P3
W612         I/O- W610JP , W610D6 , W610FP
W613         I/O- W620JP , W620D6 , W620PB , W620M6
FCBOX1       I/O- W6CIT
*04008/113126*

```

**Example 7 for /DISPLAY ASMT command**

Entry ET:

```
/DISPLAY ASMT SYSID ALL
```

Response ET:

```

LINK PLINK   SIDR SIDL MSNAME
  1 BLCB1CTC   1    4 SYSTEM2A
  1 BLCB1CTC   2    5 SYSTEM2B
  1 BLCB1CTC   3    6 FRESNO
  3 BLCB1MTM  19   20 TEST1
  2 BLCB2BSC  21   23 BOSTON
  2 BLCB2BSC  22   24 ALBANY
*90280/072821*

```

Entry ET:

```
/DISPLAY ASMT SYSID ALL
```

Response ET:

```

LINK PLINK   SIDR SIDL MSNAME   IMS1
   N/A       8    3 LINK21V3  IMS1
   N/A      28    3 ELINK211  IMS1
  5 N/A      29   19 ELINK122  IMS1
  1 PLNK12V  31   11 LINK13B3  IMS1
  1 PLNK12V  32   12 LINK13B4  IMS1
  2 PLNK12C  33   13 LINK13C2  IMS1
  3 PLNK12M  34   14 LINK13M2  IMS1
  4 N/A      35   15 LINK13U2  IMS1
 10 PLNK12V  36   16 LINK13V1  IMS1
   N/A      37    3 LINK23V2  IMS1
 12 PLNK13V  38   18 LINK13V2  IMS1
  7 N/A      43   44 ELINK124  IMS1
  6 N/A      51   41 ELINK1MS  IMS1
 10 PLNK12V  80  300 LINK13X   IMS1
 10 PLNK12V 266 2036 LINK13V   IMS1
*97258/170653*

```

Entry ET:

```
/DISPLAY ASMT SYSID 22 23 24
```

Response ET:

```

LINK PLINK   SIDR SIDL MSNAME
  2 BLCB2BSC  22   24 ALBANY
 23    IS LOCAL
 24    IS LOCAL
*90280/072902*

```

**Example 8 for /DISPLAY ASMT command**

Entry ET:

```
/DISPLAY ASMT USER A B C D
```

Response ET:

| USER | ID    | NODE   | I/O- | L1   | , L2 |
|------|-------|--------|------|------|------|
| A    | CICSA | NLUT6P | I/O- | L1   | , L2 |
| B    |       |        | I/O- | L3   |      |
| C    | CICSB | NLUT6P | I/O- | L4   |      |
| D    |       |        | I/O- | NONE |      |

\*90229/083059\*

Entry ET:

```
/DISPLAY ASMT USER IMSUS01 IMSUS02
```

Response ET:

| USER     | USERID  | ID | NODE     | I/O- | IMSUS01  |
|----------|---------|----|----------|------|----------|
| IMSUS01  | IMSUS01 |    | DTSLU201 | I/O- | IMSUS01  |
| N/A      | IMSUS01 |    | L3270A   | I/O- | T3270LA  |
| N/A      | IMSUS02 |    | L3270B   | I/O- | T3270LB  |
| DT327002 | IMSUS02 |    | DT327002 | I/O- | DT327002 |

\*92350/112229\*

Entry ET:

```
/DISPLAY ASMT USER IMSUS01*
```

Response ET:

| USER     | USERID  | ID | NODE     | I/O- | NONE    |
|----------|---------|----|----------|------|---------|
| IMSUS01C | N/A     |    |          | I/O- | NONE    |
| IMSUS01D | N/A     |    |          | I/O- | NONE    |
| IMSUS01  | IMSUS01 |    | DTSLU201 | I/O- | IMSUS01 |
| N/A      | IMSUS01 |    | L3270A   | I/O- | T3270LA |

\*92350/113904\*

Entry ET:

```
/DISPLAY ASMT USER ALL
```

Response ET:

| USER     | USERID  | ID | NODE     | I/O- | CA1SP3T1, CA1SP3T2 |
|----------|---------|----|----------|------|--------------------|
| CA13     |         |    |          | I/O- | CA1SP3T1, CA1SP3T2 |
| IMSUS01C | N/A     |    |          | I/O- | NONE               |
| IMSUS01D | N/A     |    |          | I/O- | NONE               |
| LU6SPA   | N/A     |    | LU6NDPF  | I/O- | LU6LTPA1           |
| LU6SPB   | N/A     |    |          | I/O- | LU6LTPB1, LU6LTPB2 |
| DT327002 | IMSUS02 |    | DT327002 | I/O- | DT327002           |
| IMSUS03  | IMSUS03 |    | DTSLU601 | I/O- | IMSUS03            |
| IMSUS01  | IMSUS01 |    | DTSLU201 | I/O- | IMSUS01            |
| IMSUS05  | N/A     |    |          | I/O- | NONE               |
| N/A      | IMSUS02 |    | L3270B   | I/O- | T3270LB            |
| N/A      | IMSUS01 |    | L3270A   | I/O- | T3270LA            |
| N/A      | IMSUS04 |    | L3270C   | I/O- | T3270LC            |

\*92350/114845\*

### **Example 9 for /DISPLAY ASMT command: ISC TCP/IP nodes**

In the following examples, the nodes that are shown in the command output are ISC TCP/IP nodes.

Entry ET:

```
/DIS ASMT NODE CICS
```

Response ET:

| NODE | USER    | LTERM        |
|------|---------|--------------|
| CICS | IMSUS01 | I/O- IMSUS01 |

\*12062/122917\* IMS1

Entry ET:



```
/DIS ASMT USER IMSUS01
```

Response ET:

```
USER      USERID  ID      NODE      I/O-  IMSUS01
IMSUS01   N/A     IMSUS01 CICS
*12062/122949*  IMS1
```

Entry ET:

```
/DIS ASMT LTERM IMSUS01
```

Response ET:

```
LTERM     IN-TERMINAL  OUT-TERMINAL  USER
IMSUS01   CICS        -1           CICS    -1     IMSUS01
*12062/123336*  IMS1
```

### Related reference

- [QUERY LTERM command \(Commands\)](#)
- [QUERY NODE command \(Commands\)](#)
- [QUERY USER command \(Commands\)](#)
- [QUERY USERID command \(Commands\)](#)
- [QUERY MSLINK command \(Commands\)](#)
- [QUERY MSPLINK command \(Commands\)](#)

## /DISPLAY CCTL command

Use the **/DISPLAY CCTL** command to display all coordinator controllers that are connected to DBCTL along with the pseudorecovery token, recovery token, region ID, PSB name, and status.

**Restriction:** The **/DISPLAY CCTL** command does not support the ODBA interface to IMS DB. To display status information about units of work for protected resources that are managed by z/OS Resource Recovery Services, use the **/DISPLAY UOR** command.

Subsections:

- [“Environment” on page 549](#)
- [“Syntax” on page 550](#)
- [“Keywords” on page 550](#)
- [“Output fields” on page 550](#)
- [“Examples” on page 550](#)

### Environment

The following table lists the environments (DB/DC, DBCTL, and DCCTL) in which you can use the command and keywords.

Table 276. Valid environments for the /DISPLAY CCTL command and keywords

| Command / Keywords | DB/DC | DBCTL | DCCTL |
|--------------------|-------|-------|-------|
| <b>/DISPLAY</b>    | X     | X     | X     |
| ACTIVE             | X     | X     | X     |
| CCTL               | X     | X     |       |
| INDOUBT            | X     | X     |       |

## Syntax

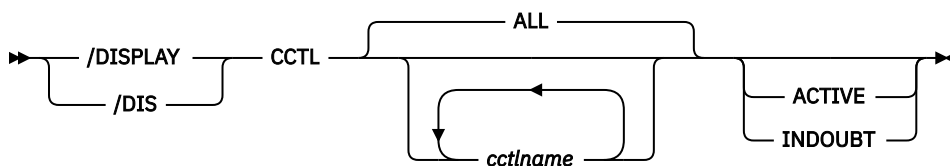

## Keywords

The following keywords are valid for the `/DISPLAY CCTL` command:

### **ALL | *cctlname***

Specifies the coordinator controllers to be displayed.

### **ALL**

Displays all coordinator controllers that are connected to IMS.

### ***cctlname***

Specifies the name of the coordinator controller. You can specify one or more coordinator controller names.

### **ACTIVE | INDOUBT**

Mutually exclusive, optional keywords that you use to specify the type of threads to be displayed.

### **ACTIVE**

Displays all currently active threads that are associated with either the specified coordinator controller name (*cctlname*) or with all coordinator controllers.

### **INDOUBT**

Displays all in-doubt threads that are associated with either the specified coordinator controller name (*cctlname*) or with all coordinator controllers.

## Output fields

Coordinator controllers that are attached to IMS show a status of ATTACHED.

The status of active threads can be any of the following:

- ACTIVE
- ACTIVE-DBCMD
- AVAILABLE
- TERM
- UNAVAIL
- W-BLKMVR
- W-INTENT
- W-POOLSP
- W-SWITCH

The status of in-doubt threads is always displayed as INDOUBT.

## Examples

The following are examples of the `/DISPLAY CCTL` command.

### **Example 1 for /DISPLAY CCTL command**

Entry ET:

```
/DISPLAY CCTL
```

Response ET:

```
CCTL          STATUS
CICS1
*89067/114857*
```

**Example 2 for /DISPLAY CCTL command**

Entry ET:

```
/DISPLAY CCTL ALL
```

Response ET:

```
CCTL          PSEUDO-RTKN RECOVERY-TOKEN  REGID  PSBNAME  STATUS
CICS1
                                00000000000000000000  3
                                00000000000000000000  2
                                00000000000000000000  1
*89067/113236*                AVAILABLE
                                AVAILABLE
                                AVAILABLE
```

**Example 3 for /DISPLAY CCTL command**

Entry ET:

```
/DISPLAY CCTL CICS1
```

Response ET:

```
CCTL          PSEUDO-RTKN RECOVERY-TOKEN  REGID  PSBNAME  STATUS
CICS1
                                9FFA9568FF594301  3  BMP255  ATTACHED
                                9FFA956B7AE24E00  2  BMP255  ACTIVE
                                00000000000000000000  1
*89067/113251*                AVAILABLE
                                ACTIVE
                                ACTIVE
```

**Example 4 for /DISPLAY CCTL command**

Entry ET:

```
/DISPLAY CCTL CICS1 ACTIVE
```

Response ET:

```
CCTL          PSEUDO-RTKN RECOVERY-TOKEN  REGID  PSBNAME  STATUS
CICS1
                                9FFA967C26D69802  2  BMP255  ATTACHED
                                9FFA967ACF9EB802  1  BMP255  ACTIVE
*89067/114557*                ACTIVE
```

**Example 5 for /DISPLAY CCTL command**

Entry ET:

```
/DISPLAY CCTL CICS1 INDOUBT
```

Response ET:

```
CCTL          PSEUDO-RTKN RECOVERY-TOKEN  REGID  PSBNAME  STATUS
CICS1
000100C0      9FFA956B7AE24E00                BMP255  ATTACHED
                                INDOUBT
```

**Related reference**

[“Status and attributes for the /DISPLAY command” on page 501](#)

A list of the attributes and status shown in the **/DISPLAY** command are described in the following table.

## **/DISPLAY CONV command**

Use the **/DISPLAY CONV** command to display all BUSY and HELD conversations in the IMS system if no other keywords or parameters are specified.

Subsections:

- [“Environment” on page 552](#)
- [“Syntax” on page 552](#)
- [“Keywords and reserved parameters” on page 553](#)
- [“Usage notes” on page 553](#)
- [“Equivalent IMS type-2 commands” on page 554](#)
- [“Output fields” on page 554](#)
- [“Examples” on page 554](#)

**Environment**

The **/DISPLAY CONV** command is valid in DB/DC and DCCTL environments.

The following table lists the environments (DB/DC, DBCTL, and DCCTL) in which you can use the command and keywords.

*Table 277. Valid environments for the /DISPLAY CONV command and keywords*

| <b>Command / Keywords</b> | <b>DB/DC</b> | <b>DBCTL</b> | <b>DCCTL</b> |
|---------------------------|--------------|--------------|--------------|
| <b>/DISPLAY</b>           | X            | X            | X            |
| CONV                      | X            |              | X            |
| LINE                      | X            |              | X            |
| NODE                      | X            |              | X            |
| USER                      | X            |              | X            |

**Syntax**

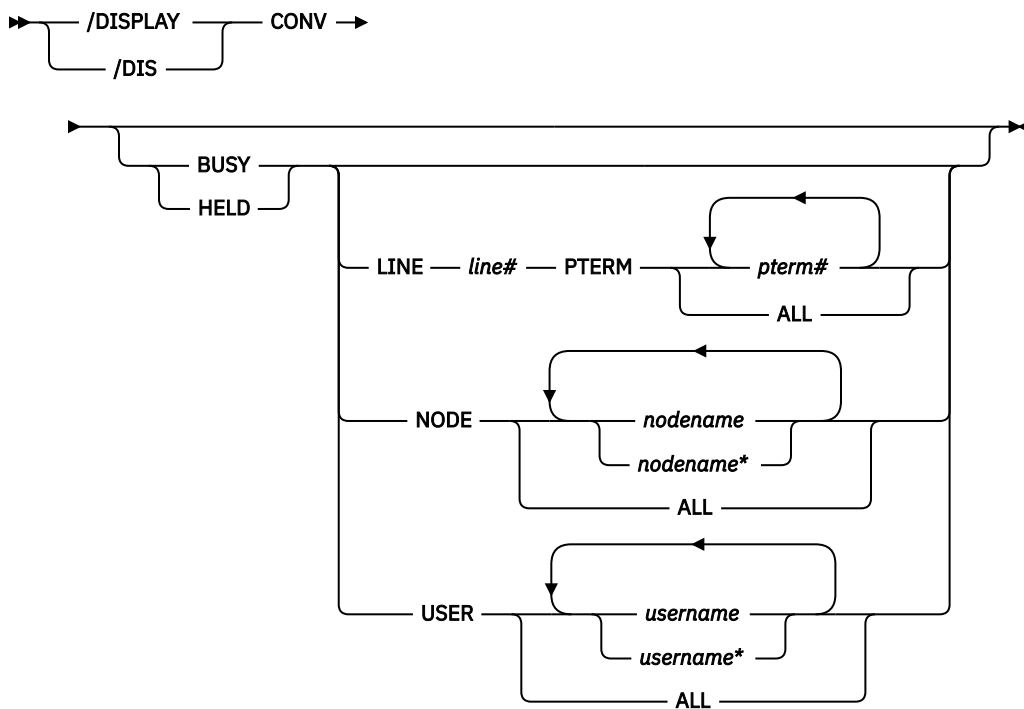

## Keywords and reserved parameters

The following keywords and reserved parameters are valid for the **/DISPLAY CONV** command:

### BUSY

The conversations currently active for the system or active for a specific node, line and physical terminal, or user.

### HELD

The conversations currently held in the system or held from a specific node, line and physical terminal, or user.

### LINE

All conversations for the specified communication line are displayed.

### NODE

All conversations for the specified node are displayed. If the NODE keyword is used and the node is an ISC node, information for all applicable sessions of the parallel session node is displayed. For dynamic terminals, the conversations of the currently associated user are displayed. The NODE parameter can be generic.

### PTERM

All conversations for the specified physical terminal are displayed.

### USER

All conversations that apply to the specified user are displayed. The USER parameter can be generic.

## Usage notes

**/DISPLAY CONVERSATION** is accepted as a valid command from an IMS terminal because CONVERSATION is a valid synonym of CONV.

When ISC is used with parallel sessions, one line of information for each session in a conversation is displayed. The user name is also displayed.



**Attention:** In an IMSplex, use of the **/DISPLAY CONV** command without a specific resource name will result in extensive accesses to the Resource Manager for global information, and its use should be carefully considered.

For an IMS conversational transaction issued from an LU 6.2 application program, the **/DISPLAY CONV** command shows the LU name and user ID (if available) of the LU 6.2 conversation along with the IMS conversation ID and status.

For an IMS conversational transaction issued from an OTMA client, the **/DISPLAY CONV** command shows the TMEMBER and TPIPE name in addition to the IMS conversation ID and status.

On an IMS XRF alternate system, where TMEMBER and TPIPE name information is not available, the literal 'UNKNOWN.OTMA' is displayed instead of the TMEMBER and TPIPE names associated with the conversation.

## Equivalent IMS type-2 commands

The following table shows variations of the **/DISPLAY CONV** command and the IMS type-2 commands that perform similar functions.

*Table 278. Type-2 equivalents for the /DISPLAY CONV command*

| <b>Task</b>  | <b>/DISPLAY CONV command</b>          | <b>Similar IMS type-2 command</b> |
|--|---------------------------------------|-----------------------------------|
| Displays nodes with active or held conversations.            | <b>/DISPLAY CONV</b>                  | QUERY NODE STATUS(CONV)           |
| Displays users with active or held conversations.            | <b>/DISPLAY CONV</b>                  | QUERY USER STATUS(CONV)           |
| Displays IMS conversation information for a particular node. | <b>/DISPLAY CONV NODE <i>node</i></b> | QUERY NODE SHOW(CONV)             |
| Displays IMS conversation information for a particular user. | <b>/DISPLAY CONV USER <i>user</i></b> | QUERY USER SHOW(CONV)             |

## Output fields

The following output fields are displayed for the **/DISPLAY CONV** command:

### **ID**

A 4-byte conversation ID, which is unique for each user and terminal.

### **STATUS**

Conversation status. The status can be ACTIVE, HELD, or SCHEDULED.

### **TERMINAL**

Physical device with which the conversation is associated. This can be a non-VTAM device/pterm, a VTAM node, an ISC node, an APPC luname, or an OTMA tmember/tpipe.

### **USER**

The user signed on to a dynamic VTAM node, or the subpool associated with an ISC node, or the user ID for an LU 6.2 conversation.

## Examples

Entry ET:

```
/DISPLAY CONV
```

Response ET:

```
TERMINAL USER  ID STATUS
NO CONVERSATIONS
*91113/182917*
```

Entry ET:

```
/DISPLAY CONV
```

Response ET:

```
TERMINAL USER  ID STATUS
11-  2          0001 HELD
4-   2          0002 ACTIVE, SCHEDULED
11-  4          0001 HELD
2-   1          0001 HELD
5-   1          0002 ACTIVE
*91115/135706*
```

Entry ET:

```
/DISPLAY CONV
```

Response ET:

```
TERMINAL USER  ID STATUS
LUNAME1  USERID1 0001 ACTIVE
DT327001 IMSUS01 0005 ACTIVE
LUNAME2          0002 ACTIVE, SCHEDULED
LUNAME3  USERID4 0003 ACTIVE, SCHEDULED
LUNAME1  USERID4 0004 SCHEDULED
*90332/114253*
```

Entry ET:

```
/DISPLAY CONV BUSY
```

Response ET:

```
TERMINAL USER  ID STATUS
NO BUSY CONVERSATIONS
*91113/182959*
```

Entry ET:

```
/DISPLAY CONV BUSY
```

Response ET:

```
TERMINAL USER  ID STATUS
2-   1          0001 ACTIVE, SCHEDULED
4-   2          0010 ACTIVE, SCHEDULED
4-   1          0011 ACTIVE, SCHEDULED
*91113/192021*
```

Entry ET:

```
/DISPLAY CONV BUSY LINE 4 PTERM ALL
```

Response ET:

```
TERMINAL USER  ID STATUS
4-   2          0001 ACTIVE, SCHEDULED
4-   1          0002 ACTIVE, SCHEDULED
*91113/192101*
```

Entry ET:

```
/DISPLAY CONV BUSY
```

Response ET:

```
TERMINAL      USER      ID STATUS
NETWORK1.LUNAME1  USERID1  0001 ACTIVE
DT327001      IMSUS01   0005 ACTIVE
NID2.LUNAME2                0002 ACTIVE,SCHEDULED
LUNAME3                USERID4  0003 ACTIVE,SCHEDULED
NETWORK1.LUNAME1  USERID5  0004 ACTIVE
*92232/114253*
```

Entry ET:

```
/DISPLAY CONV HELD
```

Response ET:

```
TERMINAL USER  ID STATUS
NO HELD CONVERSATIONS
*91113/183022*
```

Entry ET:

```
/DISPLAY CONV HELD NODE NSLUTP6
```

Response ET:

```
TERMINAL USER  ID STATUS
NSLUTP6 SPOOLA  0007 HELD
NSLUTP6 SPOOLC  000A HELD
*91113/183033*
```

### Related reference

[QUERY NODE command \(Commands\)](#)

[QUERY USER command \(Commands\)](#)

## /DISPLAY CPLOG command

Use the **/DISPLAY CPLOG** command to display the value of the IMS execution parameter, CPLOG. CPLOG specifies the number of system log records between system-generated checkpoints.

Subsections:

- [“Environment” on page 556](#)
- [“Syntax” on page 556](#)

### Environment

The **/DISPLAY CPLOG** command is valid in DB/DC, DBCTL, and DCCTL environments.

### Syntax

```
➤➤ /DISPLAY CPLOG ➤➤
   /DIS
```



## /DISPLAY CQS command

---

Use the **/DISPLAY CQS** command to display information about the Common Queue Server (CQS), including the CQS job name, version number, and current status. Valid status conditions are CONNECTED and DISCONNECTED.

Subsections:

- [“Environment” on page 557](#)
- [“Syntax” on page 557](#)
- [“Examples” on page 557](#)

### Environment

The **/DISPLAY CQS** command is valid in DB/DC and DCCTL environments.

This command is valid only in a shared-queues environment.

### Syntax



### Examples

Entry ET:

```
/DISPLAY CQS
```

Response ET:

```
JOBNAME    VERS#    STATUS
CQS1       1.1     CONNECTED
*95200/170817*
```

Explanation: IMS is connected to the Common Queue Server, CQS1.

## /DISPLAY DB command

---

Use the **/DISPLAY DB** command to display the status of the specified databases. If a specified database is a DEDB, the associated DEDB areas are also displayed.

The **/DISPLAY DB** command can be used on HALDB databases.

Subsections:

- [“Environment” on page 558](#)
- [“Syntax” on page 558](#)
- [“Keywords and reserved parameters” on page 558](#)
- [“Usage notes” on page 560](#)
- [“Equivalent IMS type-2 commands” on page 560](#)
- [“Output fields” on page 561](#)
- [“Examples” on page 563](#)

## Environment

The following table lists the environments (DB/DC, DBCTL, and DCCTL) in which you can use the command and keywords.

Table 279. Valid environments for the /DISPLAY DB command and keywords

| Command / Keywords | DB/DC | DBCTL | DCCTL |
|--------------------|-------|-------|-------|
| /DISPLAY           | X     | X     | X     |
| DB                 | X     | X     |       |
| BKERR              | X     | X     |       |

## Syntax

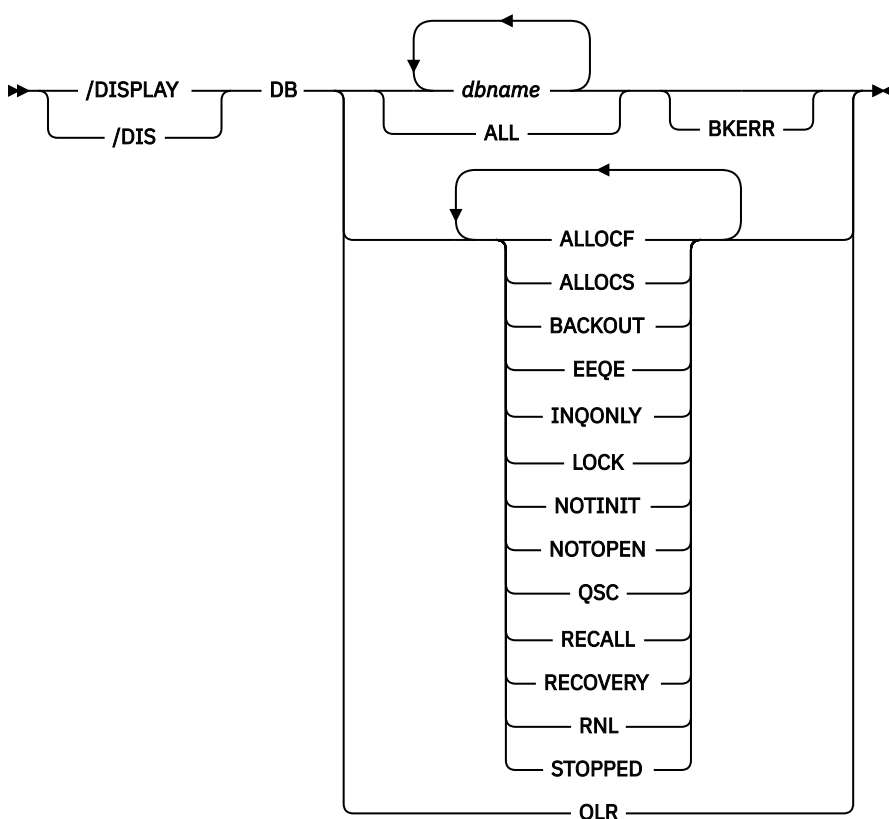

## Keywords and reserved parameters

The following keywords can be specified for the **/DISPLAY DB** command:

### BKERR

Displays the error queue elements associated with a DL/I or DEDB database. It also displays incomplete backouts preventing the use of a DL/I database.

### OLR

The **/DISPLAY DB OLR** command displays the status of a specified partition locally; that is, the status is only from the IMS where the command was issued. The **/DISPLAY DB OLR** command returns OLR information and status of all partitions that have HALDB online reorganization (OLR) cursor-active status. The following information is returned:

**RATE**

The rate at which the HALDB OLR is running, from 1 to 100

**BYTES**

The total number of bytes moved to the output data sets

**SEGMENT**

The total number of segments moved to the output data sets

**ROOTS**

The total number of roots moved to the output data sets

**STARTTIME**

The local time the OLR was first started

**STATUS**

HALDB OLR status. One or more of the following statuses are returned:

- **RUNNING** - OLR is running.
- **WAITLOCK** - OLR is waiting for a lock.
- **WAITRATE** - OLR is waiting because of an intentional delay. This intentional delay occurred because a value of less than 100 was specified for the **RATE** parameter.
- **OPTDEL** - Output data sets are deleted at the end of OLR.
- **OPTNODEL** - Output data sets are not deleted at the end of OLR.
- **RESUMED** - OLR is resumed at this IMS after being stopped for some reason such as a **TERMINATE OLREORG** command or a user abend.
- **OPTREL** - Ownership of the OLR is released if IMS terminates.
- **OPTNOREL** - Ownership of the OLR is retained if IMS terminates.
- **NOTOWNED** - OLR is not owned by this IMS.

The **/DISPLAY DB OLR** command can be issued to obtain the above information for an OLR that has been stopped for some reason such as a **TERMINATE OLREORG** command or a user abend. The data associated with the terminated OLR is maintained and provided under any of the following conditions:

- The **TERMINATE OLR** command is issued.
- Abnormal OLR termination occurs (for example, DFS2971W message is issued)
- IMS is normally shut down.

**Note:** If the partition or HALDB master has been taken offline with a **/DBR** command, or if IMS has been restarted to resume the OLR and the OLR ownership is requested before IMS restart, the status will not be available through the **/DISPLAY DB OLR** command until the OLR is resumed. The status, however, can be obtained through the **LIST .DB** or **LIST .RECON** command.

The OLR attribute cannot be specified on the **/DISPLAY DB** command with any other attribute such as **STOPPED** or **ALLOC**. If additional attributes are specified, the command is rejected and message, DFS0135 is displayed.

If a **/DISPLAY DB OLR** command is issued on an XRF alternate, the message, DFS132I - ALL PARAMETERS ARE INVALID is displayed.

Attributes are reserved parameters for the **/DISPLAY DB** command and cannot be used to name databases. The attributes in the following list can be used with the **DB** keyword. Databases are selected for display based on the attribute or attributes specified. The attribute display format is the same as the standard **DB** display. Attributes usually correspond to the conditions displayed for databases.

**ALLOCF**

Displays the databases whose allocation failed.

**ALLOCS**

Displays the databases whose allocation was successful.

**BACKOUT**

Displays the databases with incomplete backouts, which prevent the use of the databases.

**EEQE**

Displays the databases that are associated with one or more error queue elements.

**INQONLY**

Displays the databases for which a **/DBDUMP** command was issued.

**LOCK**

Displays the databases that are locked.

**NOTINIT**

Displays the databases for which directory initialization failed.

**NOTOPEN**

Displays the databases that are not in open status. This status is not applicable to MSDBs.

**OLR**

Displays the databases that have online reorganization in progress.

**Restriction:** The OLR attribute cannot be entered with any other attribute.

**QSC**

Displays the databases that have the status of quiesced or quiescing.

**RECALL**

Displays the databases that are in recall.

**STOPPED**

Displays the databases that are stopped.

## Usage notes

If you use the **/DISPLAY** command to identify OLRs that are terminated using the **TERMINATE OLREORG** command, it does not report status for partitions that have not been authorized. Alternately, use the commands **QUERY OLREORG STATUS (NOTOWNED)** with **ROUTE(\*)** on the command request, and **/RMLIST DBRC='DB DBD(partname)'**. If all systems on the PLEX show status NOTOWNED, and the DBRC database record shows an OLR active cursor, then OLR has been terminated.

When you enter this command, the database name can be an existing non-HALDB, a HALDB master, or a HALDB partition. A command against a HALDB partition operates exactly like a command against a non-HALDB except for the **/START DB** and the **UPDATE DB START(ACCESS)** command. A HALDB partition is not allocated during the command unless it was previously authorized but not allocated, the **OPEN** keyword was specified, or the partition has EEQEs. The partition is allocated at first reference.

The HALDB partition reflects conditions such as STOPPED, LOCKED, or NOTOPEN. When a HALDB partition is stopped, it must be explicitly started again. Commands with the keyword **ALL** and commands against a HALDB master do not change the STOPPED and LOCKED indicators in each HALDB partition.

When the command target is a HALDB master, processing acts on all HALDB partitions. For example, if the IMS command is **/DBR** on the HALDB master, all of the HALDB partitions are closed, deallocated, and deauthorized. Only the HALDB master displays STOPPED (each HALDB partition does not display STOPPED unless it was itself stopped). If a **/DBR** command was issued against a HALDB master, the display output of a **/DISPLAY DB** command shows the HALDB master (as STOPPED), but does not display the status of the partitions.

Each partition inherits the access limitations of its HALDB master. If the **/DBD** command is issued against a HALDB master, all of its partitions close. A subsequent reference to any of the partitions results in the partition opening for input, although the partition's access might be **UPDATE** or **EXCLUSIVE**. The DBRC authorization state reflects the limited access.

## Equivalent IMS type-2 commands

The following table shows variations of the **/DISPLAY DB** command and the IMS type-2 commands that perform similar functions.

Table 280. Type-2 equivalents for the /DISPLAY DB command

| Task                               | /DISPLAY DB command                            | Similar IMS type-2 command |
|------------------------------------|--|----------------------------|
| Displays the status of a database. | /DISPLAY DB <i>dbname1 ...dbnamen</i><br>  ALL | QUERY DB                   |

## Output fields

The following output fields are displayed for the /DISPLAY DB command:

### DB

Name of the database.

### TYPE

Type of database:

- DL/I
- DEDB
- DHISNDX (refers to Fast Path secondary index databases)
- MSNR (refers to MSDB non-related databases)
- MSRD (refers to MSDB-related dynamic databases)
- MSRF (refers to MSDB-related fixed databases)
- PHIDAM
- PHDAM
- PSINDEX
- PART
- blank (if the database status is NOTINIT)

### TOTAL SEQ DEPEND

Total control intervals defined for sequential dependent space, which applies to areas associated with DEDBs. This column appears only if Fast Path is installed.

### UNUSED SEQ DEPEND

Unused control intervals for sequential dependent space. This column appears only if Fast Path is installed.

### TOTAL DIRECT ADDRESS

Total control intervals for independent overflow part of direct addressable space, which applies to areas associated with DEDBs. This column appears only if Fast Path is installed.

### UNUSED DIRECT ADDRESS

Total unused control intervals for independent overflow part of a direct addressable space, which applies to areas associated with DEDBs. This column appears only if Fast Path is installed. This IOVF count is updated on a timed basis, with a default timer of 2 hours.

### ACC

Type of access to the database, which can be one of the following:

#### RO

Read only

#### RD

Read

#### UP

Update

#### EX

Exclusive

## **CONDITIONS**

Status conditions of the database, which can be one or more of the following:

- ALLOCF
- ALLOCS
- BACKOUT
- EEQE
- INQONLY
- LOCK
- NOTINIT
- NOTOPEN
- OLR
- QUIESCED
- QUIESCING
- RECALL
- RECOVERY
- RNL
- STOPPED

The **/DISPLAY DB** command with the BKERR keyword displays error queue elements associated with a DL/I database and displays incomplete backouts.

The following output fields are displayed by the **/DISPLAY DB** command with the BKERR keyword:

### **DATABASE**

Name of the database with error queue elements or backout pending data.

### **ERROR DD**

DDNAME of the data set with the error queue element

### **TYPE**

Type of error queue element, which is one of the following:

#### **BACK PSB**

PSB needing backout

#### **BLOCK**

OSAM block number or VSAM CI RBA

#### **DATE**

Date

#### **IDT**

In-doubt

#### **IDT+WRT**

In-doubt and write error

#### **IDT+IOT**

In-doubt and I/O toleration

#### **IOT**

I/O toleration

#### **IOT/VSO**

I/O toleration for VSO areas

#### **PRM**

DBRC permanent

**RD**

Read error

**TIME**

Time

**USE**

DBRC user created

**WRT**

Write error

**BLOCK**

The **/DISPLAY DB** command with BKERR does not display individual RBAs for I/O tolerated non-SDEP CIs of a DEDB area defined with the Virtual Storage Option (VSO). Instead, a single entry with a value of 00000001 is displayed; the EEQE type is set to IOT/VSO. I/O tolerated SDEP CIs for the area are displayed individually by RBA.

The EEQE information might not be current if the database is registered with DBRC and is not open, because IMS updates EEQE information from DBRC when the database is opened.

**Examples**

The following are examples of the **/DISPLAY DB** command.

**Example 1 for /DISPLAY DB command**

Entry ET:

```
/DISPLAY DB ALL
```

Response ET:

| DATABASE       | TYPE | TOTAL | UNUSED | TOTAL  | UNUSED | ACC | CONDITIONS |
|----------------|------|-------|--------|--------|--------|-----|------------|
| DD41M702       | DL/I |       |        |        |        | EX  | NOTOPEN    |
| DD41M803       | DL/I |       |        |        |        | EX  | NOTOPEN    |
| DEDBJN21       | DEDB | SEQ   | DEPEND | DIRECT | ADDRES | EX  | NOTOPEN    |
| DB21AR0        | AREA | N/A   | N/A    | N/A    | N/A    |     | NOTOPEN    |
| DB21AR1        | AREA | N/A   | N/A    | N/A    | N/A    |     | NOTOPEN    |
| DB21AR2        | AREA | N/A   | N/A    | N/A    | N/A    |     | NOTOPEN    |
| DB21AR3        | AREA | N/A   | N/A    | N/A    | N/A    |     | NOTOPEN    |
| DB21AR4        | AREA | N/A   | N/A    | N/A    | N/A    |     | NOTOPEN    |
| DB21AR5        | AREA | N/A   | N/A    | N/A    | N/A    |     | NOTOPEN    |
| DB21AR6        | AREA | N/A   | N/A    | N/A    | N/A    |     | NOTOPEN    |
| DB21AR7        | AREA | N/A   | N/A    | N/A    | N/A    |     | NOTOPEN    |
| DB21AR8        | AREA | N/A   | N/A    | N/A    | N/A    |     | NOTOPEN    |
| DB21AR9        | AREA | N/A   | N/A    | N/A    | N/A    |     | NOTOPEN    |
| DB21AR10       | AREA | N/A   | N/A    | N/A    | N/A    |     | NOTOPEN    |
| DB21AR11       | AREA | N/A   | N/A    | N/A    | N/A    |     | NOTOPEN    |
| DEDBJN22       | DEDB | SEQ   | DEPEND | DIRECT | ADDRES | EX  | NOTOPEN    |
| DB22AR0        | AREA | N/A   | N/A    | N/A    | N/A    |     | NOTOPEN    |
| DB22AR1        | AREA | N/A   | N/A    | N/A    | N/A    |     | NOTOPEN    |
| DEDBJN23       | DEDB | SEQ   | DEPEND | DIRECT | ADDRES | EX  | NOTOPEN    |
| DB23AR0        | AREA | N/A   | N/A    | N/A    | N/A    |     | NOTOPEN    |
| DB23AR1        | AREA | N/A   | N/A    | N/A    | N/A    |     | NOTOPEN    |
| DIMSRN01       | DL/I |       |        |        |        | EX  | NOTOPEN    |
| DIMSRN02       | DL/I |       |        |        |        | EX  | NOTOPEN    |
| DIMSRN03       | DL/I |       |        |        |        | EX  | NOTOPEN    |
| *89184/142639* |      |       |        |        |        |     |            |

Entry ET:

```
/DISPLAY DB DD41M803 BKERR
```

Response ET:

```
DATABASE
DD41M803
```

```

      ERROR DD   TYPE      BLOCK
      DD41M803  IOT       0000003F
*90135/161902*

```

Explanation: An I/O toleration error queue element exists for database DD41M803 on a newly created active system in an XRF environment.

Following an **/UNLOCK SYSTEM** command on the above system, the **/DISPLAY DB DD41M803 BKERR** command would yield the following display:

```

DATABASE
DD41M803
      NO EEQE OR INCOMPLETE BACKOUT INFORMATION AVAILABLE
*90135/163500*

```

### Example 2 for /DISPLAY DB command

Entry ET:

```
/DIS DB BE3ORDER BE3PARTS.
```

Response ET:

```

DATABASE  TYPE  TOTAL UNUSED  TOTAL UNUSED  ACC  CONDITIONS
BE3ORDER  DL/I                               EX  STOPPED, LOCK, NOTOPEN,
                                     RECALL
BE3PARTS  DL/I                               EX  NOTOPEN, RECALL
*94277/124039*

```

### Example 3 for /DISPLAY DB command

Entry ET:

```
/DIS DB RECALL.
```

Response ET:

```

DATABASE  TYPE  TOTAL UNUSED  TOTAL UNUSED  ACC  CONDITIONS
BE3ORDER  DL/I                               EX  STOPPED, LOCK, NOTOPEN,
                                     RECALL
BE3PARTS  DL/I                               EX  NOTOPEN, RECALL
IVPDB1    DL/I                               UP  STOPPED, LOCK, NOTOPEN,
                                     RECALL
IVPDB2    DL/I                               UP  NOTOPEN, RECALL
*94277/124119*

```

### Example 4 for /DISPLAY DB command

Entry ET:

```
/DISPLAY DB DEDBJN21 BKERR
```

Response ET:

```

DATABASE
DEDBJN21
      ERROR DD   TYPE      BLOCK
      DB21AR0   IOT       00015000
      DB21AR0   IOT/VSO  00000001
      DB21AR1   IOT       00054000
      DB21AR1   IOT/VSO  00000001

```

Explanation: The **/DISPLAY DB** command with the **BKERR** keyword does not display individual RBAs for I/O tolerated non-SDEP CIs of a DEDB area defined with the Virtual Storage Option (VSO). Instead, a single entry with a value of 00000001 is displayed and the EEQE type is set to IOT/VSO. I/O tolerated SDEP CIs for the area are displayed individually by RBA.

### Example 5 for /DISPLAY DB command



If a full function database data set is undergoing recovery with Online Recovery Service, the output of the **/DISPLAY DB** command includes this information in the command response.

Entry ET:

```
/DISPLAY DB DD41M702
```

Response ET:

| DATABASE       | TYPE | TOTAL UNUSED | TOTAL UNUSED | ACC | CONDITIONS             |
|----------------|------|--------------|--------------|-----|------------------------|
| DD41M702       | DL/I |              |              | EX  | STOPPED, LOCK, NOTOPEN |
| *97184/142639* |      |              |              |     |                        |

**Example 6 for /DISPLAY DB command**

Display the HALDB master for the PHIDAM database called PARTMAST.

Entry ET:

```
/DIS DB PARTMAST
```

Response ET:

| DATABASE       | TYPE   | TOTAL UNUSED | TOTAL UNUSED | ACC | CONDITIONS |
|----------------|--------|--------------|--------------|-----|------------|
| PARTMAST       | PHIDAM |              |              | UP  |            |
| PART1          | PART   |              |              | UP  | ALLOCS     |
| PART2          | PART   |              |              | UP  | NOTOPEN    |
| PART3          | PART   |              |              | UP  | STOPPED    |
| *99166/092514* |        |              |              |     |            |

**Example 7 for /DISPLAY DB command**

Display the HALDB partition for PHIDAM PART2.

Entry ET:

```
/DIS DB PART2
```

Response ET:

| DFS000I        | DATABASE | TYPE   | TOTAL UNUSED | TOTAL UNUSED | ACC | CONDITIONS |
|----------------|----------|--------|--------------|--------------|-----|------------|
| DFS000I        | PARTMAST | PHIDAM |              |              | UP  |            |
| DFS000I        | PART2    | PART   |              |              | UP  | NOTOPEN    |
| *99166/092737* |          |        |              |              |     |            |

**Example 8 for /DISPLAY DB command**

Display output for an online reorganization with ownership retention. If ownership is not retained during a termination, OPTREL is replaced with OPTNOREL.

Entry ET:

```
/DIS DB OLR
```

Response ET:

| DATABASE                 | PART    | RATE | BYTES | SEGS | ROOTS | STARTTIME    |
|--------------------------|---------|------|-------|------|-------|--------------|
| STATUS                   |         |      |       |      |       |              |
| DBHDOJ01                 | PDHDOJB | 1    | 0     | 0    | 0     | 07295/143354 |
| WAITRATE, OPTNODEL       |         |      |       |      |       |              |
| DBHDOJ01                 | PDHDOJA | 1    | 3330  | 17   | 1     | 07295/143354 |
| WAITRATE, OPTDEL, OPTREL |         |      |       |      |       |              |
| DBHDOJ01                 | PDHDOJC | 1    | 1400  | 5    | 2     | 07295/143354 |

WAITLOCK, OPTNODEL  
\*07295/143358\*

Explanation: Issue the **/DISPLAY DB OLR** command to obtain information about all HALDB online reorganizations that are running in cursor-active status. The following information is returned:

- Master database name
- Partition name
- OLR rate
- Number of bytes moved
- Number of segments moved
- Number of roots moved
- Start time of the OLR when it was first started
- Status of the progress of OLR
- OLR inactive data set option
- Date/Time stamp when the command was processed
- OLR options, including whether OLR ownership is released if IMS terminates before completing the reorganization
- OLR wait status, if any

**Note:** For partitions in NOTOWNED status, if the OLR statistics information is unavailable, only the master database name, partition name, and status are displayed.

#### **Example 9 for /DISPLAY DB command**

Entry ET:

```
/DISPLAY DB QSC
```

Response ET:

| DATABASE | TYPE   | TOTAL UNUSED | TOTAL UNUSED | ACC | CONDITIONS                |
|----------|--------|--------------|--------------|-----|---------------------------|
| AUTODB   | DL/I   |              |              | UP  | NOTOPEN, QUIESCING        |
| DBHIDJ03 | PHIDAM |              |              | UP  |                           |
| POHIDJC  | PART   |              |              | UP  | NOTOPEN, QUIESCED         |
| DBOHIDK5 | PHIDAM |              |              | UP  | QUIESCED                  |
| POHIDKA  | PART   |              |              | UP  | NOTOPEN, ALLOCS, QUIESCED |
| POHIDKB  | PART   |              |              | UP  | NOTOPEN, QUIESCED         |
| POHIDKC  | PART   |              |              | UP  | NOTOPEN, QUIESCED         |
| POHIDKD  | PART   |              |              | UP  | NOTOPEN, QUIESCED         |
| DBOVLFPD | DL/I   |              |              | UP  | NOTOPEN, QUIESCING        |

Explanation: Issue the **/DISPLAY DB QSC** command to obtain information about all databases that have the status of quiesced or quiescing.

#### **Example 10 for /DISPLAY DB command**

In this example, TYPE is set to DHISNDX for a HISAM or a SHISAM secondary index database.

Entry ET:

```
/DISPLAY DB ALL
```

Response ET:

| DATABASE | TYPE  | TOTAL UNUSED | TOTAL UNUSED | ACC    | CONDITIONS | IMS1    |         |      |
|----------|-------|--------------|--------------|--------|------------|---------|---------|------|
| DBHDOJ01 | PHDAM |              |              | UP     |            | IMS1    |         |      |
| PDHDOJA  | PART  |              |              | UP     | NOTOPEN    | IMS1    |         |      |
| PDHDOJB  | PART  |              |              | UP     | NOTOPEN    | IMS1    |         |      |
| PDHDOJC  | PART  |              |              | UP     | NOTOPEN    | IMS1    |         |      |
| PDHDOJD  | PART  |              |              | UP     | NOTOPEN    | IMS1    |         |      |
| DEDBJN24 | DEDB  | SEQ          | DEPEND       | DIRECT | ADDRES     | UP      | NOTOPEN | IMS1 |
| DB24A000 | AREA  | N/A          | N/A          | N/A    | N/A        | NOTOPEN | IMS1    |      |
| DB24A001 | AREA  | N/A          | N/A          | N/A    | N/A        | NOTOPEN | IMS1    |      |
| DB24A239 | AREA  | N/A          | N/A          | N/A    | N/A        | NOTOPEN | IMS1    |      |

Explanation: DBHDOJ01 is a PHDAM database with four partitions: PDHDOJA, PDHDOJB, PDHDOJC, and PDHDOJD. DEDBJN24 is a DEDB database with three areas: DB24A000, DB24A001, and DB24A239. DEHSJX24 is a HISAM or a SHISAM secondary index database. The local access of each database is UPDATE.

**Related reference**

“Status and attributes for the /DISPLAY command” on page 501

A list of the attributes and status shown in the /DISPLAY command are described in the following table.

Parameter descriptions for IMS procedures (System Definition)

QUERY DB command (Commands)

## /DISPLAY DBD command

Use the /DISPLAY DBD command to display, for databases that are being accessed, their type, the PSBs accessing them, and the type of access.

Subsections:

- “Environment” on page 567
- “Syntax” on page 567
- “Equivalent IMS type-2 commands” on page 567
- “Examples” on page 567

**Environment**

The /DISPLAY DBD command is valid in DB/DC and DBCTL environments.

**Syntax**

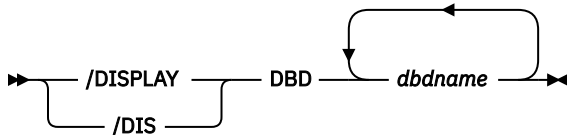

**Equivalent IMS type-2 commands**

The following table shows variations of the /DISPLAY DBD command and the IMS type-2 commands that perform similar functions.

Table 281. Type-2 equivalents for the /DISPLAY DBD command

| Task   | /DISPLAY DBD command        | Similar IMS type-2 command                   |
|--|-----------------------------|--|
| Displays the programs being accessed by databases. | /DISPLAY DBD <i>dbdname</i> | QUERY DB NAME( <i>dbdname</i> )<br>SHOW(PGM) |

**Examples**

Entry ET:

```
/DISPLAY DBD MSDBLM01 MSDBLM02 MSDBLM03 MSDBLM04
```

Response ET:

| DBD-NAME       | TYPE | PSB-NAME | ACCESS |
|----------------|------|----------|--------|
| MSDBLM01       | MSDB | DDLTLM06 | R/W    |
|                |      | DDLTLM07 | R/W    |
| MSDBLM02       | MSDB | DDLTLM06 | R/W    |
|                |      | DDLTLM07 | R/W    |
| MSDBLM03       | MSDB | DDLTLM06 | R/W    |
|                |      | DDLTLM07 | R/W    |
| MSDBLM04       | MSDB | DDLTLM06 | R/W    |
|                |      | DDLTLM07 | R/W    |
| *91068/110958* |      |          |        |

### Related reference

[QUERY DB command \(Commands\)](#)

## /DISPLAY DESC command

Use the **/DISPLAY DESC** command to display LU 6.2 descriptors. All specified values are displayed, as are defaults/blanks for values not specified in the descriptor.

Subsections:

- [“Environment” on page 568](#)
- [“Syntax” on page 568](#)
- [“Output fields” on page 568](#)
- [“Examples” on page 569](#)

### Environment

The **/DISPLAY DESC** command is valid in DB/DC and DCCTL environments.

### Syntax

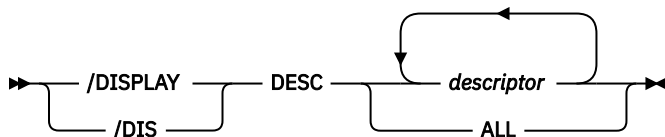

### Output fields

The following output fields are displayed for the **/DISPLAY DESC** command:

#### DESC

Name of the descriptor.

#### LUNAME

LU name value in the descriptor. The network-qualified LU name is optional for the LUNAME keyword.

#### MODE

VTAM LOGON mode table entry value in the descriptor.

#### OUTBNDLU

Shows which local-LU will be used for APPC outbound processing when the descriptor is used.

#### SIDE

APPC z/OS side table entry value in the descriptor.

**SYNCLEVEL**

APPC synchronous level in the descriptor; either NONE or CONFIRM.

**TPNAME**

TP name value in the descriptor. If the tpname is too long, a + is appended at the end, and the rest is continued on a second line.

**TYPE**

APPC conversation type value in the descriptor; it is either BASIC or MAPPED.

**Examples**

Entry ET:

```
/DISPLAY DESC ALL
```

Response ET:

```
DESC      LUNAME      MODE  SIDE      SYNCLEVEL  TYPE      OUTBNDLU
LU62DES1  NID2.LUNAME4  ALPHA  SIDENME1  CONFIRM    MAPPED    MYLU02
  TPNAME: ACCOUNT
LU62DES2  LUNAME7      BETHA  SIDENME2  NONE       BASIC
  TPNAME: APPLE67890123456789012345
*92232/114253*
```

## **/DISPLAY FDR command**

Use the **/DISPLAY FDR** command to display the current status for IMS Fast Database Recovery regions.

IMS rejects this command if the active IMS subsystem is not connected to a Fast Database Recovery region.

Subsections:

- [“Environment” on page 569](#)
- [“Syntax” on page 569](#)
- [“Output fields” on page 569](#)
- [“Examples” on page 570](#)

**Environment**

The **/DISPLAY FDR** command is valid in DB/DC and DBCTL environments.

**Syntax**

```
→ /DISPLAY FDR →
  /DIS
```

**Output fields**

The following output fields are displayed for the **/DISPLAY FDR** command:

**FDR-REGION**

Status of the Fast Database Recovery region to which the IMS subsystem is connected. The status can be ACTIVE or NO\_ACTIVE.

## GROUPNAME

The z/OS cross-system coupling facility (XCF) group name specified in the DFSFDRxx member of IMS.PROCLIB.

## TIMEOUT

The failure-detection timeout value specified in the DFSFDRxx member or set by a **/CHANGE FDR** command.

## Examples

Entry ET:

```
/DISPLAY FDR
```

Response ET:

```
FDR-REGION  GROUPNAME  TIMEOUT
ACTIVE      FDBRSYS3   055
*96232/114253*
```

## **/DISPLAY FPV command**

Use the **/DISPLAY FPV** command to display the areas loaded into a z/OS data space or coupling facility. That is, those areas that have been specified with the virtual storage option (VSO) are displayed with this command.

Subsections:

- [“Environment” on page 570](#)
- [“Syntax” on page 570](#)
- [“Output fields” on page 570](#)
- [“Examples” on page 571](#)

## Environment

The **/DISPLAY FPV** command is valid in DB/DC and DBCTL environments.

## Syntax

```
➤ /DISPLAY FPV ➤
  /DIS
```

## Output fields

Each data space is displayed, along with each of the areas that reside in the data space. All numbers shown are in decimal values.

The following output fields are displayed by the **/DISPLAY FPV** command:

### DATASPACE

Data space number.

### MAXSIZE(4K)

Maximum available size, in 4 KB blocks. This is the amount of space available in the data space for user data.

**AREANAME**

Name of the area located in the data space or in the coupling facility.

**AREASIZE(4K)**

Actual storage available for a particular area, in 4 KB blocks. The actual space usage can be significantly less than what is reserved if a VSO dataspace is not preloaded.

**OPTION**

A data space option (which can be DREF) or an area option (which can be PREL or PREO). Area options are defined to DBRC with the **INIT . DBDS** or **CHANGE . DBDS** command.

**STRUCTURE**

Name of the coupling facility structure allocated for this area.

**ENTRIES**

Number of area CIs in the structure.

**CHANGED**

Number of area CIs in the structure that have been updated. IMS writes these updated CIs to DASD (and resets this value) when you enter any of the following commands:

- **/CHECKPOINT**
- **/STOP AREA**
- **/VUNLOAD**

**AREACI#**

Total number of area CIs that can be loaded into the structure.

**POOLNAME**

Name of the private buffer pool used by the area.

**Examples**

Entry ET:

```
/DISPLAY FPV
```

Response ET:

| DATASPACE      | MAXSIZE(4K) | AREANAME | AREASIZE(4K) | OPTION     | SYS3 |
|----------------|-------------|----------|--------------|------------|------|
| 001            | 524188      | DB21AR1  | 76           | PREO       |      |
|                |             | DB21AR11 | 152          |            |      |
| 000            | 524188      | DB21AR0  | 19           | PREO, PREL |      |
|                |             | DB21AR10 | 19           | PREO, PREL |      |
|                |             | DB21AR2  | 38           | PREO, PREL |      |
| *93076/173254* |             |          |              |            |      |

Entry ET:

```
/DISPLAY FPV
```

Response ET:

| DATASPACE      | MAXSIZE(4K) | AREANAME | AREASIZE(4K) | OPTION       |            |
|----------------|-------------|----------|--------------|--------------|------------|
| 000            | 524263      | DB21AR4  | 167          | PREO, PREL   |            |
|                |             | DB21AR2  | 42           | PREO, PREL   |            |
| 001            | 524263      | DB21AR3  | 84           | PREO         |            |
|                |             | DB21AR1  | 84           |              |            |
| CF             | POOL        | CACHE    | AREANAME     | AREASIZE(4K) | OPTION     |
| CF1            | 4K          | N        | AREAFR01     | 1000         | PREO, PREL |
| CF2            | 512         | Y        | AREA2        | 100          | PREO, PREL |
| *95225/173254* |             |          |              |              |            |

Entry ET:

```
/DISPLAY FPV
```

Response ET:

```
DATASPACE MAXSIZE(4K) AREANAME AREASIZE(4K) OPTION      SYS3
          000      524238
                      DB21AR1          19 PREO, PREL
                      DB21AR0          19 PREO, PREL
                      DB23AR1          19 PREO, PREL
          001      524238
NO AREAS LOADED INTO NORM DATASPACE 001. SYS3
          002      524238
NO AREAS LOADED INTO NORM DATASPACE 002. SYS3
AREANAME STRUCTURE ENTRIES CHANGED AREA CI# POOLNAME OPTIONS  SYS2
*03129/145840* SYS3
```

Entry ET:

```
/DISPLAY FPV
```

Response ET:

```
AREANAME STRUCTURE ENTRIES CHANGED AREA CI# POOLNAME OPTIONS
DB33FR01 DB33FR01STRUCTUR 0000150 0000018 00000150 FR01 PREO, PREL
DB21AR9 MAS1KSTR 0000043 0000043 00000270 MAS1K PREO
DB21AR8 MAS1KSTR 0000044 0000044 00000150 MAS1K PREO
DD01AR0 DD01AR0STR1 0000045 0000025 00000045 DD01 PREO, PREL
DB21AR10 MAS512STR 0000084 0000084 00000150 V$$$512 PREO
DB21AR3 MAS2KSTR 0000150 0000015 00000150 MAS2K PREO, PREL
DB21AR1 MAS2KSTR 0000150 0000126 00000150 MAS2K PREO, PREL
DB21AR0 MAS512STR 0000150 0000001 00000150 V$$$512 PREO, PREL
DB21AR4 MAS4KSTR 0000010 0000010 00000150 MAS4K PREO
DB21AR11 MAS4KSTR 0000010 0000010 00000150 MAS4K PREO
DB21AR5 MAS1KSTR 0000044 0000044 00000150 MAS1K PREO
DB21AR6 MAS512STR 0000077 0000077 00000150 V$$$512 PREO
DB21AR7 MAS1KSTR 0000040 0000040 00000150 MAS1K PREO
DB21AR2 MAS1KSTR 0000044 0000044 00000150 MAS1K PREO
```

Explanation: Each area using a multi-area structure is listed individually with its own statistics. Column AREACI# displays the total number of CIs in the root addressable part. This is the total number of CIs loaded into the structure if the entire Area was preloaded.

## **/DISPLAY HSSP command**

Use the **/DISPLAY HSSP** command to display information about the current HSSP (high-speed sequential processing) activities.

Subsections:

- [“Environment” on page 572](#)
- [“Syntax” on page 572](#)
- [“Output fields” on page 573](#)
- [“Examples” on page 573](#)

### **Environment**

The **/DISPLAY HSSP** command is valid in DB/DC and DBCTL environments.

### **Syntax**





## Output fields

The following output fields are displayed for the **/DISPLAY HSSP** command:

### **RGN**

Region ID as displayed in the **/DISPLAY ACTIVE** command (three digit PST number)

### **TYP**

Region type (BMP only)

### **JOBNAME**

Job name

### **PSB**

Program Specification Block name

### **DB**

Database name

### **AREAS-OPTIONS**

Information on the SETO statement:

#### **AREA**

Area name

#### **PCB**

Information on whether the named area has updated intent.

#### **PROCOPT**

Whether PROCOPT H is specified.

#### **IC**

Image Copy in process.

#### **UPD**

Information on whether the area is updated, which is one of the following:

#### **N**

The PCB has no update intent on the named area.

#### **Y**

The PCB has update intent on the named area.

#### **OPTION**

Information on the execution

#### **IC**

Image Copy in process

## Examples

Entry ET (Active System):

```
/DISPLAY HSSP
```

Response ET:

```
RGN TYP JOBNAME PSB DATABASE AREAS-OPTIONS SYS3
  1 BMP CSSP020B BMPFPE02 DEDBJN21 IC=(1,C) SYS3
*89122/094325* SYS3
```

## **/DISPLAY LINE command**

---

The **/DISPLAY LINE** command, when followed by a valid line number or ALL, displays the status and queue counts for the specified communication line or lines and physical terminal.

The queue count for **/DISPLAY LINE** is reset to zero after an IMS cold start.

Subsystems:

- [“Environment” on page 574](#)
- [“Syntax” on page 574](#)
- [“Keywords” on page 575](#)
- [“Reserved parameters” on page 575](#)
- [“Usage notes” on page 576](#)
- [“Output fields” on page 577](#)
- [“Examples” on page 577](#)

### **Environment**

The following table lists the environments (DB/DC, DBCTL, and DCCTL) in which you can use the command and keywords.

*Table 282. Valid environments for the /DISPLAY LINE command and keywords*

| <b>Command / Keywords</b> | <b>DB/DC</b> | <b>DBCTL</b> | <b>DCCTL</b> |
|---------------------------|--------------|--------------|--------------|
| <b>/DISPLAY</b>           | X            | X            | X            |
| LINE                      | X            |              | X            |
| QCNT                      | X            |              | X            |
| PTERM                     | X            |              | X            |

### **Syntax**

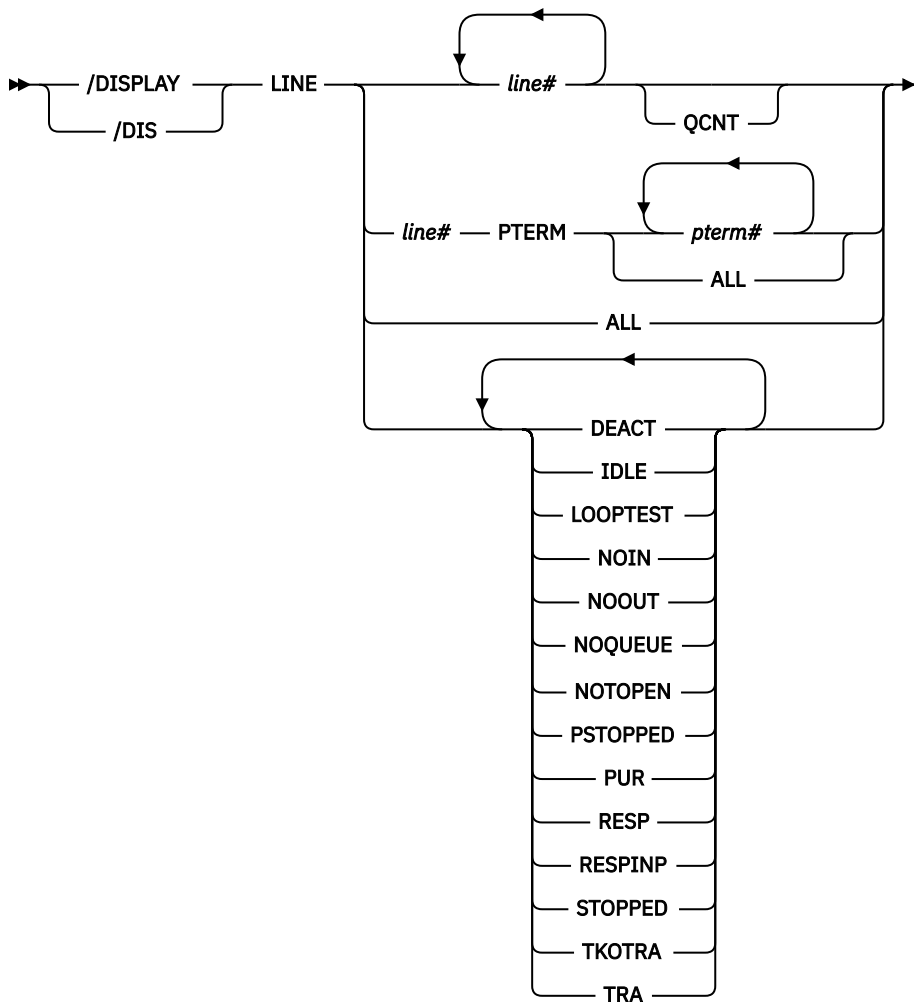

## Keywords

The following keywords are valid for the **/DISPLAY LINE** command:

### QCNT

Specifies that global queue count information is to be displayed. If QCNT is not specified, local queue counts are displayed; when it is specified, no local queue counts are displayed.

This keyword is valid only in a shared-queues environment.

### PTERM

Is used to refer to a relative physical terminal. Valid parameters are number corresponding to the relative position of the terminal on the line. When used without the LINE keyword on the **/DISPLAY** command, valid parameters are physical terminal attributes.

## Reserved parameters

Lines are selected for display based on the attributes specified. Attributes that can be used with the LINE keyword are shown in the following table. The attribute display format is the same as the standard LINE display. The attributes correspond to the conditions displayed for lines. For example, **/DISPLAY LINE LOOPTEST** displays all lines that are currently in looptest mode.

Table 283. /DISPLAY LINE command attributes

| Attributes List #1 | Attributes List #2 | Attributes List #3 |
|--------------------|--------------------|--------------------|
| DEACT              | IDLE               | LOOPTEST           |
| NOIN               | NOOUT              | NOQUEUE            |
| NOTOPEN            | PSTOPPED           | PUR                |
| RESP               | RESPINP            | STOPPED            |
| TKOTRA             | TRA                |                    |

**DEACT**

Displays the lines that have been permanently deactivated. Message DFS2473 in the system console log might contain information regarding the reason this status was set. DFS2473 can occur more than once in the system console log.

**IDLE**

Displays the lines for which no activity of any kind is in progress for them.

**LOOPTEST**

Displays the lines that are in looptest mode.

**NOIN**

Displays the lines that are stopped for input.

**NOOUT**

Displays the lines that are stopped for output.

**NOQUEUE**

Displays the lines that have had message queuing stopped for message switching.

**NOTOPEN**

Displays the lines that are not in open status.

**PSTOPPED**

Displays the lines that have been stopped by the /PSTOP command. This status might indicate that a different, necessary resource is unavailable.

**PUR**

Displays the lines that are purging all of their output.

**RESP**

Displays the lines that are in input response mode and the response reply message is available for output or in the process of being sent.

**RESPINP**

Displays the lines that are in full-function input response mode and the response mode input is still in-doubt; for example, the response reply message is not available for output.

**STOPPED**

Displays the lines that are stopped.

**TKOTRA**

Displays the lines that are to be traced only during takeover to help diagnose XRF terminal switch problems.

**TRA**

Displays the lines that are being traced.

**Usage notes**

In a shared-queues environment, use the QCNT keyword to obtain the current message queue counts on the shared queues structure. The local queue counts (ENQCT, DEQCT, and QCT) value that is returned on this command when the QCNT keyword is not specified represents the messages being processed by the IMS system where this command is issued. Do not use local queue counts for queue evaluation purposes.

## Output fields

The following output fields are displayed by the **/DISPLAY LINE** command.

- LIN/PTE
- TYPE
- ADDR
- RECD
- ENQCT
- DEQCT
- QCT
- SENT
- Status
  - IDLE
  - NOTOPEN
  - STOPPED
  - COMPINOP

## Examples

Entry ET:

```
/DISPLAY LINE 1, 3, 10
```

Response ET:

| LINE | TYPE    | ADDR | RECD | ENQCT | DEQCT | QCT | SENT |
|------|---------|------|------|-------|-------|-----|------|
| 1    | CONSOLE | **** | 0    | 1     | 0     | 1   | 6    |
| 3    | 3270 R  | 0C9  | 43   | 51    | 43    | 8   | 79   |

\*85098/141118\*

Entry ET:

```
/DISPLAY LINE ALL
```

Response ET:

| LINE | TYPE    | ADDR | RECD | ENQCT | DEQCT | QCT | SENT |         |              |
|------|---------|------|------|-------|-------|-----|------|---------|--------------|
| 1    | CONSOLE | **** | 4    | 1     | 1     | 0   | 6    |         |              |
| 2    | 3270 R  | 0C9  | 43   | 51    | 43    | 8   | 79   |         |              |
| 3    | 3270 L  | **** | 0    | 0     | 0     | 0   | 0    | STOPPED | IDLE         |
| 4    | 3270 L  | 1234 | 20   | 22    | 20    | 2   | 0    |         |              |
| 5    | RDR/PTR | **** | 0    | 0     | 0     | 0   | 0    | STOPPED | IDLE         |
| 6    | RDR/PTR | **** | 0    | 0     | 0     | 0   | 0    | STOPPED | IDLE         |
| 7    | RDR/PTR | **** | 0    | 0     | 0     | 0   | 0    | STOPPED | IDLE         |
| 8    | RDR/PTR | **** | 0    | 0     | 0     | 0   | 0    | STOPPED | IDLE         |
| 9    | DIAL    | POOL |      | 0     | 0     | 0   | 0    | POOL    | STOPPED IDLE |

\*85098/141244\*

Entry ET:

```
/DISPLAY LINE 5 PTERM ALL
```

Response ET:

| LIN/PTE | TYPE     | ADDR   | RECD | ENQCT | DEQCT | QCT | SENT       |
|---------|----------|--------|------|-------|-------|-----|------------|
| 5-      | 1 3270 R | 404081 | 3    | 6     | 6     | 0   | 8          |
| 5-      | 2 3270 R | C14081 | 0    | 6     | 6     | 0   | 7          |
| 5-      | 3 3270 R | C1C181 | 40   | 30    | 28    | 2   | 61         |
| 5-      | 4 3270 R | C1C281 | 0    | 3     | 0     | 3   | 0 COMPINOP |
| 5-      | 5 3270 R | C1C381 | 0    | 3     | 0     | 3   | 0 COMPINOP |

```
5- 6 3270 R C1C481 0 3 3 0 3
*85098/141412*
```

Entry ET:

```
/DISPLAY LINE PSTOPPED, PUR
```

Response ET:

```
LINE   TYPE  ADDR  RECD ENQCT DEQCT  QCT  SENT
   4   3270 R  ****  4    8    8    0    33  PUR IDLE NOTOPEN
  18   3270 R  022   0    4    4    0    4  PSTOPPED IDLE
*85098/141283*
```

## **/DISPLAY LINK command**

The **/DISPLAY LINK** command, when followed by a valid link number or ALL, displays the status and queue counts for the specified logical link.

The queue count for the **/DISPLAY LINK** command is reset to zero after an IMS cold start.

In addition, the **/DISPLAY LINK** command shows if the logical link is assigned to a physical link and the partner identification that is assigned to it during system definition.

Subsections:

- [“Environment” on page 578](#)
- [“Syntax” on page 578](#)
- [“Keywords” on page 579](#)
- [“Usage notes” on page 579](#)
- [“Output fields” on page 579](#)
- [“Examples” on page 580](#)

### **Environment**

The following table lists the environments (DB/DC, DBCTL, and DCCTL) in which you can use the command and keywords.

*Table 284. Valid environments for the /DISPLAY LINK command and keywords*

| <b>Command / Keywords</b> | <b>DB/DC</b> | <b>DBCTL</b> | <b>DCCTL</b> |
|---------------------------|--------------|--------------|--------------|
| <b>/DISPLAY</b>           | X            | X            | X            |
| LINK                      | X            |              | X            |
| MODE                      | X            |              | X            |
| OPTION                    | X            |              | X            |
| QCNT                      | X            |              | X            |

### **Syntax**

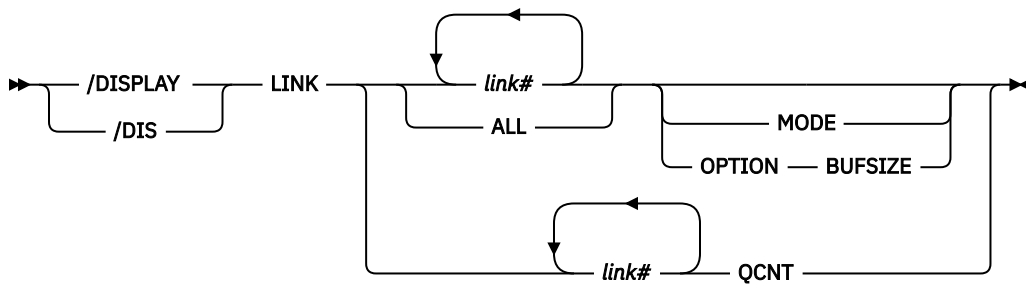

## Keywords

The following keywords are valid for the **/DISPLAY LINK** command:

### MODE

Displays various modes in which VTAM terminals can operate.

### OPTION

Specifies the following:

#### BUFSIZE

Displays the link parameters such as the link number, link name, bandwidth, buffer size, and the link status.

### QCNT

Specifies that global queue count information is to be displayed. If QCNT is not specified, local queue counts are displayed; when it is specified, no local queue counts are displayed.

This count represents the message counts of messages that can be processed by the IMS system where the command is issued. This count includes messages that can be processed by any IMS system (messages with no affinity), plus messages that can be processed by the IMS system where the command is issued (messages with an affinity to the IMS system that issued the command).

This keyword is valid only in a shared-queues environment.

## Usage notes

The **/DISPLAY LINK link# MODE** command, when entered from the primary IMS system, displays in the ACT MODETBL field the mode table name from the **/RESTART** command or LOGON exit. The same field does not display on the secondary IMS system.

**Note:** N/A is displayed by **/DISPLAY LINK ALL MODE** for non-VTAM MSC links.

In a shared-queues environment, use the QCNT keyword to obtain the current message queue counts on the shared queues structure. The local queue counts (ENQCT, DEQCT, and QCT) value that is returned on this command when the QCNT keyword is not specified represents the messages being processed by the IMS system where this command is issued. Do not use local queue counts for queue evaluation purposes.

## Output fields

The following output fields are displayed by the **/DISPLAY LINK** command:

### ACT MODETBL

Mode table name actually used to initiate the session. This name is displayed only if the MODE keyword is specified and only while the session is active. The field is blank at normal session termination.

### BUFSIZE

Link buffer size. The link buffer size is displayed only if the OPTION BUFSIZE keyword is specified.

**DEF MODETBL**

Default mode table name set by system definition or **/CHANGE** command. This name can be overridden with the **/RSTART** command or, for non-IMS session initiations, the LOGON exit. This name is displayed only if the MODE keyword is specified.

**DEQCT**

Count of messages dequeued.

**ENQCT**

Count of messages enqueued.

**LINK**

Logical link number.

**LINKNAME**

Name of the logical link. The link name is displayed only if the OPTION BUFSIZE keyword is specified on the **/DISPLAY LINK** command.

**PARTNER**

The identification specified during IMS system definition for this multiple system partnership.

**QCT**

The current count of messages queued.

**RECD**

Count of messages received.

**SENT**

Count of messages sent.

**STATUS**

Displays the link status.

**Examples**

The following are example of the **/DISPLAY LINK** command.

**Example 1 for /DISPLAY LINK command**

Entry ET:

```
/DISPLAY LINK ALL
```

Response ET:

| LINK | PARTNER | RECD | ENQCT | DEQCT | QCT | SENT | STATUS               |
|------|---------|------|-------|-------|-----|------|----------------------|
| 1    | AB      | 0    | 0     | 0     | 0   | 0    | PSTOPPED IDLE COLD   |
| 2    | AC      | 8    | 21    | 12    | 9   | 12   | NOTIDLE-C0C ACTV TRA |
| 3    | AD      | 4    | 6     | 6     | 0   | 6    | IDLE ACTV TRA        |
| 4    | BC      | 0    | 0     | 0     | 0   | 0    | PSTOPPED IDLE COLD   |
| 5    | AE      | 0    | 3     | 0     | 3   | 0    | PSTOPPED IDLE        |

\*91293/171240\*

**Example 2 for /DISPLAY LINK command**

Entry ET:

```
/DISPLAY LINK 1 3
```

Response ET:

| LINK | PARTNER | RECD | ENQCT | DEQCT | QCT | SENT | STATUS        |
|------|---------|------|-------|-------|-----|------|---------------|
| 1    | AB      | 0    | 1     | 0     | 1   | 0    | IDLE          |
| 3    | AD      | 0    | 0     | 0     | 0   | 0    | PSTOPPED IDLE |

\*90280/072548\*

**Example 3 for /DISPLAY LINK command**



Entry ET:

```
/DISPLAY LINK ALL MODE
```

Response ET:

| LINK | PARTNER | DEF    | MODETBL | ACT | MODETBL |
|------|---------|--------|---------|-----|---------|
| 1    | AB      | N/A    |         | N/A |         |
| 2    | AC      | N/A    |         | N/A |         |
| 3    | AD      | N/A    |         | N/A |         |
| 4    | AE      | N/A    |         | N/A |         |
| 5    | AK      | MSC12V |         |     |         |
| 6    | AL      | MS12V  |         |     |         |

\*90179/102238\*

Explanation: N/A is displayed in the mode table name fields of non-VTAM MSC links. MSC12V and MS12V are mode table names defined at system definition or established using the **/CHA** command.

#### **Example 4 for /DISPLAY LINK command**

Entry ET:

```
/DISPLAY LINK 10 OPTION BUFSIZE
```

Response ET:

| DFS000I | LINK           | LINKNAME | BUFSIZE | STATUS                            |
|---------|----------------|----------|---------|-----------------------------------|
| DFS000I | 10             | LNK12V02 | 4096    | IDLE ACTV PRI FORCE TRA BANDWIDTH |
| DFS000I | *06108/153639* |          |         |                                   |

Explanation: The link buffer size of 4096 and the bandwidth status are displayed.

#### **Example 5 for /DISPLAY LINK command**

The following two examples show the output of the **/DISPLAY LINK** command when a link uses TCP/IP as the physical link type. TCP/IP link types always use MSC bandwidth mode, so in the second example, BANDWIDTH indicates that the bandwidth mode is used by the link.

Entry ET:

```
/DIS LINK 4
```

Response ET:

| DFS000I | LINK | PARTNER | RECD | ENQCT | DEQCT | QCT | SENT | PSTOPPED | IDLE | COLD |
|---------|------|---------|------|-------|-------|-----|------|----------|------|------|
| DFS000I | 4    | TA      | 0    | 0     | 0     | 0   | 0    |          |      |      |

Entry ET:

```
/DIS LINK 4 OPTION BUFSIZE
```

Response ET:

| DFS000I | LINK | LINKNAME | BUFSIZE | STATUS                       |
|---------|------|----------|---------|------------------------------|
| DFS000I | 4    | LNK12T01 | 8192    | PSTOPPED IDLE COLD BANDWIDTH |

## **/DISPLAY LTERM command**

Use the **/DISPLAY LTERM** command to display status and queue counts for the specified logical terminal name.

Subsections:

- [“Environment” on page 582](#)
- [“Syntax” on page 582](#)
- [“Keywords” on page 582](#)

- “Usage notes” on page 583
- “Equivalent IMS type-2 commands” on page 583
- “Output fields” on page 583
- “Examples” on page 584

## Environment

The following table lists the environments (DB/DC, DBCTL, and DCCTL) in which you can use the command and keywords.

Table 285. Valid environments for the /DISPLAY LTERM command and keywords

| Command / Keywords | DB/DC | DBCTL | DCCTL |
|--------------------|-------|-------|-------|
| /DISPLAY           | X     | X     | X     |
| EMHQ               | X     |       | X     |
| LTERM              | X     |       | X     |
| QCNT               | X     |       | X     |

## Syntax

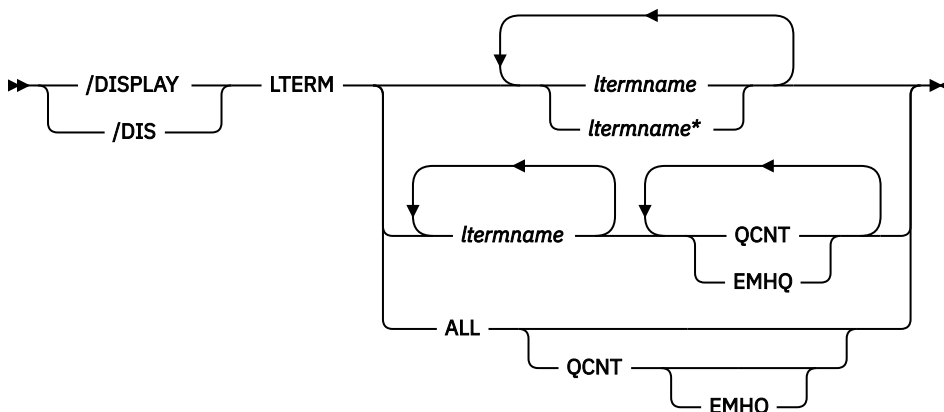

## Keywords

The following keywords can be specified for the /DISPLAY LTERM command:

### EMHQ

Specifies that global queue count information on the Expedited Message Handler Queues (EMHQ) displays when both EMHQ and QCNT are specified. If EMHQ is specified, QCNT must also be specified. This keyword is only valid in a shared-queues environment.

### QCNT

Specifies that global queue count information is to be displayed. If QCNT is not specified, local queue counts are displayed; when it is specified, no local queue counts are displayed. If QCNT is specified and EMHQ is not, global queue count information on the shared message queues (MSGQ) is displayed.

This count represents the message counts of messages that can be processed by the IMS system where the command is issued. This count includes messages that can be processed by any IMS system (messages with no affinity), plus messages that can be processed by the IMS system where the command is issued (messages with an affinity to the IMS system that issued the command).

IMS does not check if the specified name is a valid LTERM in the IMS subsystem on which the command is entered.

The **/DISPLAY LTERM ALL QCNT** command displays all of the LTERMs on the shared queues with a global queue count.

This command does not display queue counts for Fast Path output messages for the NODE unless EMHQ and QCNT are specified.

This keyword is only valid in a shared-queues environment.

For IMS subsystems in a shared-queues environment with the time control option, TCO, enabled, AFFIN has been added to the queue names of TCO LTERMs. When the **/DISPLAY LTERM DFSTCFI QCNT** command is issued, the queue count of messages for the DFSTCFI LTERM pertains to the TCO LTERM on the local IMS subsystem. The queue count is zero prior to adding AFFIN to the queue names.

## Usage notes

The LTERM parameter can be generic where the generic parameter specifies lterms that already exist.

**/DISPLAY LTERM ALL** does not display lterms in alphabetical order.

In a shared-queues environment, there are certain situations that cause an LTERM message to be retrieved from the global queue and moved to the local queue, but the message has not been delivered. If this occurs, the global queue count is zero and you need to display the local queue to see the output message.

In a shared-queues environment, use the QCNT keyword to obtain the current message queue counts on the shared queues structure. The local queue counts (ENQCT, DEQCT, and QCT) value that is returned on this command when the QCNT keyword is not specified represents the messages being processed by the IMS system where this command is issued. Do not use local queue counts for queue evaluation purposes.

## Equivalent IMS type-2 commands

The following table shows variations of the **/DISPLAY LTERM** command and the IMS type-2 commands that perform similar functions.

Table 286. Type-2 equivalents for the **/DISPLAY LTERM** command

| Task  | <b>/DISPLAY LTERM</b> command   | Similar IMS type-2 command |
|---|---|----------------------------|
| Displays logical link path for remote lterms. | <b>/DISPLAY LTERM</b> <i>ltermname</i>  | QUERY LTERM SHOW(MSNAME)   |
| Displays the lterm message queue count.       | <b>/DISPLAY LTERM</b> <i>ltermname</i><br><b>/DISPLAY LTERM</b> <i>ltermname</i> QCNT | QUERY LTERM SHOW(QCNT)     |
| Displays status of the lterm.                 | <b>/DISPLAY LTERM</b> <i>ltermname</i>  | QUERY LTERM SHOW(STATUS)   |
| Displays queue count in the EMH queues.       | <b>/DISPLAY LTERM</b> <i>ltermname</i> QCNT<br>EMHQ                                   | QUERY LTERM SHOW(EMHQ)     |

## Output fields

The status displayed can be one of the following:

- LOCK
- PSTOP
- PUR

- QERR
- QLOCK
- STATIC
- STOP

### Examples

The following are examples of the **/DISPLAY LTERM** command.

#### **Example 1 for /DISPLAY LTERM command**

Entry ET:

```
/DISPLAY LTERM DIALQ1 INQUIRY1 L2740S1 L2740SM1 MASTER WTOR
```

Response ET:

| LTERM          | ENQCT | DEQCT | QCT |      |
|----------------|-------|-------|-----|------|
| DIALQ1         | 0     | 0     | 0   |      |
| INQUIRY1       | 0     | 0     | 0   |      |
| L2740S1        | 1     | 1     | 0   | STOP |
| L2740SM1       | 1     | 0     | 1   | STOP |
| MASTER         | 12    | 12    | 0   |      |
| WTOR           | 0     | 0     | 0   |      |
| *90295/123755* |       |       |     |      |

#### **Example 2 for /DISPLAY LTERM command**

Entry ET:

```
/DISPLAY LTERM ALL
```

Response ET:

| LTERM          | ENQCT | DEQCT | QCT |       |
|----------------|-------|-------|-----|-------|
| DSPLY1         | 0     | 0     | 0   |       |
| DSPLY2         | 0     | 0     | 0   |       |
| DSPLY3         | 0     | 0     | 0   |       |
| MASTER         | 8     | 8     | 0   |       |
| WTOR           | 0     | 0     | 0   |       |
| 2740AA1        | 0     | 0     | 0   |       |
| 2740AA2        | 0     | 0     | 0   |       |
| 2740AA3        | 0     | 0     | 0   |       |
| 2740C1         | 0     | 0     | 0   |       |
| 2740C2         | 0     | 0     | 0   |       |
| 2740SM1        | 2     | 2     | 0   | STOP  |
| 2740SM2        | 2     | 2     | 0   | STOP  |
| 2740S1         | 1     | 1     | 0   |       |
| 2740S2         | 1     | 1     | 0   | QERR  |
| LU6A           | 1     | 1     | 0   | QLOCK |
| *91276/125448* |       |       |     |       |

#### **Example 3 for /DISPLAY LTERM command**

Entry ET:

```
/DISPLAY LTERM LTERMA LTERM123 ABCD QCNT
```

Response ET:

| LTERM          | GBLQCT     |
|----------------|------------|
| LTERMA         | 1000000000 |
| LTERM123       | 25         |
| ABCD           | 0          |
| *95200/170817* |            |

#### Example 4 for /DISPLAY LTERM command

Entry ET:

```
/DISPLAY LTERM EMHQ QCNT
```

(one user is on the queue)

Response ET:

```
LTERM      GBLQCT
FPE0001    1
*98203/145857*
```

#### Example 5 for /DISPLAY LTERM command

Entry ET:

```
/DIS LTERM ALL QCNT EMHQ
```

Response ET:

```
LTERM      GBLQCT    SYS3
IMSUS01    1         SYS3
IMSUS02    1         SYS3
*04310/132048*
```

#### Related reference

[“Status and attributes for the /DISPLAY command” on page 501](#)

A list of the attributes and status shown in the **/DISPLAY** command are described in the following table.

[QUERY LTERM command \(Commands\)](#)

## /DISPLAY LUNAME command

Use the **/DISPLAY LUNAME** command to display information about a specific LU 6.2 application program.

After restart and any checkpoint, only LU 6.2 resources with status or messages queued are displayed.

If you use a side information entry name to place messages on queues, specify the side information entry name for the LU name and the character string DFFSIDE for the TP name to display those messages.

Subsections:

- [“Environment” on page 585](#)
- [“Syntax” on page 586](#)
- [“Keywords” on page 586](#)
- [“Usage notes” on page 587](#)
- [“Output fields” on page 587](#)
- [“Examples” on page 588](#)

### Environment

The following table lists the environments (DB/DC, DBCTL, and DCCTL) in which you can use the command and keywords.

Table 287. Valid environments for the /DISPLAY LUNAME command and keywords

| Command / Keywords | DB/DC | DBCTL | DCCTL |
|--------------------|-------|-------|-------|
| <b>/DISPLAY</b>    | X     | X     | X     |
| INPUT              | X     |       | X     |

Table 287. Valid environments for the /DISPLAY LUNAME command and keywords (continued)

| Command / Keywords | DB/DC | DBCTL | DCCTL |
|--------------------|-------|-------|-------|
| LUNAME             | X     |       | X     |
| OUTPUT             | X     |       | X     |
| QCNT               | X     |       | X     |
| TPNAME             | X     |       | X     |

## Syntax

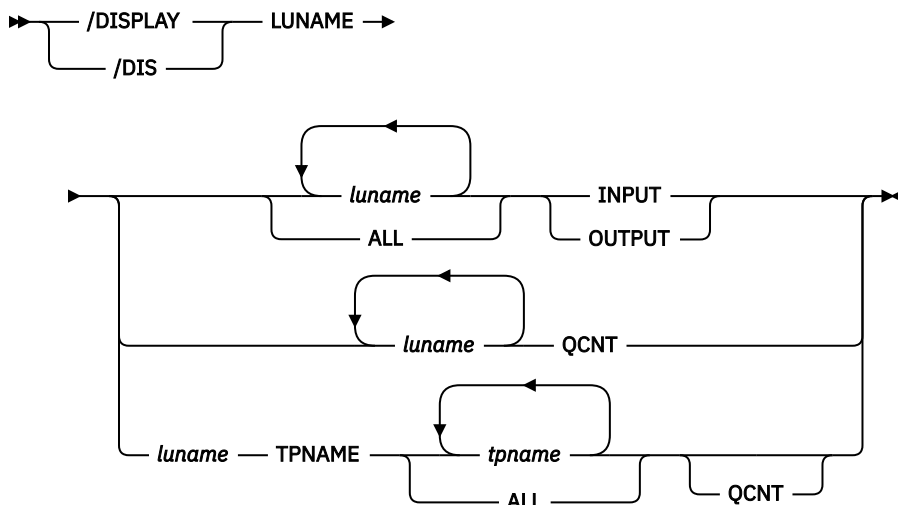

## Keywords

The following keywords are valid for the **/DISPLAY LUNAME** command:

### LUNAME

The LU name of the LU 6.2 application program about which you want to display information.

### INPUT

Displays the count of LU 6.2 inbound conversations and synchronous outbound activities for the specified LU names and their status.

**/DISPLAY LUNAME INPUT** can indicate that a command such as the **/STO LU ALL INPUT** command or the **/TRACE SET ON LU ALL INPUT** command was entered before the display that applies to all future LU 6.2 inbound conversations.

### OUTPUT

Displays the count of asynchronous output messages that are being enqueued and dequeued for the LU name and the count of LU 6.2 asynchronous outbound conversations for that LU name.

The **/DISPLAY LUNAME OUTPUT** command can indicate that a command such as the **/STO LU ALL OUTPUT** command or the **/TRACE SET ON LU ALL OUTPUT** command was entered that applies to all future LU 6.2 outbound conversations.

### QCNT

Displays the number of output messages on the global queue for the specified LU name. QCNT specifies that global queue count information is to be displayed. Local queue counts are not displayed.

This count represents the message counts of messages that can be processed by the IMS system where the command is issued. This count includes messages that can be processed by any IMS system (messages with no affinity), plus messages that can be processed by the IMS system where the command is issued (messages with an affinity to the IMS system that issued the command).

The **/DISPLAY LUNAME QCNT** form of the command is only valid in a shared-queues environment.

## **TPNAME**

Displays the number of asynchronous output messages being enqueued and dequeued and their status.

If the LU name includes a network identifier, you must specify the network-qualified LU name when using the TPNAME keyword. A network-qualified LU name refers to a different resource than a non-qualified LU name.

## **Usage notes**

In a shared-queues environment, use the QCNT keyword to obtain the current message queue counts on the shared queues structure. The local queue counts (ENQCT, DEQCT, and QCT) value that is returned on this command when the QCNT keyword is not specified represents the messages being processed by the IMS system where this command is issued. Do not use local queue counts for queue evaluation purposes.

## **Output fields**

The following output fields are displayed for the **/DISPLAY LUNAME** command:

### **LUNAME**

LU name of the LU 6.2 application program

### **#APPC-CONV**

The number of LU 6.2 inbound conversations

### **ENQCT**

Total number of messages enqueued on this LU name. In a shared-queues environment, only shows messages enqueued for the local subsystem.

### **DEQCT**

Total number of messages dequeued from this LU name. In a shared-queues environment, only shows messages dequeued for the local subsystem.

### **QCT**

Total number of messages still in the queue. In a shared-queues environment, only shows messages enqueued for the local subsystem.

### **CONVCT**

Number of LU 6.2 asynchronous outbound conversations.

Status can be stopped (STO), traced (TRA), or stopped and traced.

The CONVCT output field only applies if the OUTPUT keyword was specified.

### **GBLQCNT**

The total number of APPC output messages on the global queue. The global queue count includes messages that were placed on the global queue prior to the latest cold start of the owning IMS. Synchronous and asynchronous APPC output messages are included in the global queue count.

### **AFFINITY**

The IMSID (or the first seven bytes of the RSENAME if XRF capable) of the IMS to which the output messages have affinity.

### **Status**

The status displayed can be none, stopped (STO), traced (TRA), or both stopped and traced. The status information does not have a header.

## Examples

Entry ET:

```
/DISPLAY LU luname1 luname2 INPUT
```

Response ET:

```
LUNAME      #APPC-CONV
LUNAME1          15 TRA
LUNAME2          5
*90332/114253*
```

Entry ET:

```
/DISPLAY LU luname1 luname3 BADLUNME OUTPUT
```

Response ET:

```
LUNAME      ENQCT      DEQCT      QCT      CONVCT
LUNAME1          5          3          2          2
LUNAME3          5          4          1          1
BADLUNME IS INVALID
*90332/114253*
```

Entry ET:

```
/DISPLAY LU LUNAME1 TPNAME TPNAME1 BADTPNME
```

Response ET:

```
LUNAME/TPNAME      ENQCT      DEQCT      QCT
LUNAME1
-TPNAME1              0          0          0 STO
BADTPNME IS INVALID
*90332/114253*
```

Entry ET:

```
/DISPLAY LU LUNAME1 TPNAME ALL OUTPUT
```

Response ET:

```
LUNAME/TPNAME      ENQCT      DEQCT      QCT
LUNAME1
-TPNAME1              0          0          0 STO
-TPNAME7890123456+  5          3          2 TRA,STO
789END
-DFSSIDE              2          2          0
*90332/114253*
```

Entry ET:

```
/DISPLAY LU LUNAME2 TPNAME ALL
```

Response ET:

```
LUNAME/TPNAME      ENQCT      DEQCT      QCT
NO TPNAME(S) ASSOCIATED WITH LUNAME
*90332/114253*
```

Entry ET:

```
/DISPLAY LU 'network1.luname1' luname3 'nid2.luname4' OUTPUT
```

Response ET:



| LUNAME           | ENQCT | DEQCT | QCT | CONVCT |
|------------------|-------|-------|-----|--------|
| NETWORK1.LUNAME1 | 5     | 3     | 2   | 2      |
| LUNAME3          | 5     | 4     | 1   | 1      |
| NID2.LUNAME4     | 0     | 0     | 0   | 0      |
| *92232/114253*   |       |       |     |        |

Entry ET:

```
/DISPLAY LU 'network1.luname1' TPNAME tpname1 badtpnme
```

Response ET:

| LUNAME/TPNAME    | ENQCT      | DEQCT | QCT   |
|------------------|------------|-------|-------|
| NETWORK1.LUNAME1 |            |       |       |
| -TPNAME1         | 0          | 0     | 0 STO |
| -BADTPNME        | IS INVALID |       |       |
| *92232/114253*   |            |       |       |

Entry ET:

```
/DISPLAY LU ALL INPUT
```

Response ET

| LUNAME         | #APPC-CONV |
|----------------|------------|
| NET1.LU1       | 0 STO,TRA  |
| NET2.LU1       | 0          |
| LU3            | 0 STO,TRA  |
| NET4.LU3       | 0 STO      |
| NET5.LU5       | 0 TRA      |
| FUTURE INPUT:  | STO,TRA    |
| *93069/114435* |            |

Entry ET:

```
/DISPLAY LU ALL OUTPUT
```

Response ET:

| LUNAME         | ENQCT   | DEQCT | QCT | CONVCT    |
|----------------|---------|-------|-----|-----------|
| NET1.LU1       | 0       | 0     | 0   | 0 STO     |
| NET2.LU1       | 0       | 0     | 0   | 0 TRA     |
| LU3            | 0       | 0     | 0   | 0 STO,TRA |
| NET4.LU3       | 0       | 0     | 0   | 0 TRA     |
| NET5.LU5       | 0       | 0     | 0   | 0 STO     |
| FUTURE OUTPUT: | STO,TRA |       |     |           |
| *93069/114435* |         |       |     |           |

Entry ET:

```
/DISPLAY LU L62MVS1 LU1 CTA73 QCNT
```

Response ET:

| LUNAME         | GBLQCT | AFFINITY |
|----------------|--------|----------|
| DEBVMU00.CTA73 | 8      | SYS3     |
| L62MVS1        | 22     | SYS3     |
| CTA73          | 6      | SYS3     |
| NTWKA.CTA73    | 16     | SYS3     |
| L62MVS1        | 26     | IMS2     |
| NTWKA.CTA73    | 4      | IMS2     |
| LU1            | 0      |          |
| *03202/143132* |        |          |

Entry ET:

```
/DIS LU CTA73 TPNAME ALL QCNT
```

Response ET:

| LUNAME/TPNAME  | GBLQCT | AFFINITY |
|--|--------|----------|
| DEBVMU00.CTA73   |        |          |
| -DFAASYNC  | 8      | SYS3     |
| CTA73  |        |          |
| -TPNM012345678901+   | 6      | SYS3     |
| 23456789012345678901234567890123456789012345678901234567890123456789 |        |          |
| NTWKA.CTA73  |        |          |
| -TP100   | 4      | IMS2     |
| -TP100   | 16     | SYS3     |
| *03202/143204*   |        |          |

Entry ET:

```
/DIS LU LU100 TPNAME TP100 TP300 TP200 QCNT
```

Response ET:

| LUNAME/TPNAME  | GBLQCT | AFFINITY |
|----------------|--------|----------|
| NTWK2.LU100    |        |          |
| -TP100         | 8      | IMS2     |
| NTWK1.LU100    |        |          |
| -TP100         | 8      | IMS2     |
| -TP200         | 10     | IMS2     |
| LU100          |        |          |
| -TP300         | 0      |          |
| *03202/143201* |        |          |

Entry ET:

```
/DIS LU SIDENAME TPNAME DFSSIDE QCNT
```

Response ET:

| LUNAME/TPNAME  | GBLQCT | AFFINITY |
|----------------|--------|----------|
| SIDENAME       |        |          |
| -DFSSIDE       | 9      | IMS2     |
| *03202/143231* |        |          |

### Related reference

[“Command keywords and their synonyms” on page 59](#)

All IMS command keywords and their synonyms, as well as keywords supported by the OM API, are listed. The list covers command keywords for the OM command processing clients such as IMS, ODBM, IMSCON, and RM.

## **/DISPLAY MASTER** command

Use the **/DISPLAY MASTER** command to display the logical terminal name and the line and physical terminal number associated with the master terminal.

If the 3270 master terminal capability was generated during IMS system definition, the logical terminal name, line, and physical terminal number of the secondary master terminal are also displayed.

Subsections:

- [“Environment” on page 590](#)
- [“Syntax” on page 591](#)
- [“Equivalent IMS type-2 commands” on page 591](#)
- [“Examples” on page 591](#)

### Environment

The **/DISPLAY MASTER** command is valid in DB/DC and DCCTL environments.

## Syntax

➤ `/DISPLAY MASTER` ➤  
`/DIS`

## Equivalent IMS type-2 commands

The following table shows variations of the `/DISPLAY MASTER` command and the IMS type-2 commands that perform similar functions.

Table 288. Type-2 equivalents for the `/DISPLAY MASTER` command

| Task  | <code>/DISPLAY MASTER</code> command | Similar IMS type-2 command                |
|---|--------------------------------------|---|
| Displays the primary and secondary master terminal. | <code>/DISPLAY MASTER</code>         | <code>QUERY LTERM STATUS(MTO,SMTO)</code> |

### Examples

Entry ET:

```
/DISPLAY MASTER
```

Response ET:

```
LTERM MASTER  
PTERM 3- 1  
*89117/130245*
```

### Related reference

[QUERY LTERM command \(Commands\)](#)

## `/DISPLAY MODIFY` command

Use the `/DISPLAY MODIFY` command to display online change status for this IMS, which is participating in a local or global online change.

The command displays the following information:

- Online change libraries
- Work in progress for resources to be deleted or changed by a `/MODIFY COMMIT` or a `INITIATE OLC PHASE(PREPARE)` command
- Resources to be added, changed, and deleted by a `/MODIFY COMMIT` or an `INITIATE OLC PHASE(COMMIT)` command

Subsections:

- [“Environment” on page 592](#)
- [“Syntax” on page 592](#)
- [“Keywords” on page 592](#)
- [“Usage notes” on page 594](#)
- [“Equivalent IMS type-2 commands” on page 594](#)
- [“Output fields” on page 594](#)
- [“Examples” on page 598](#)

## Environment

The **/DISPLAY MODIFY** command is valid in DB/DC, DBCTL, and DCCTL environments.

The following table lists the environments (DB/DC, DBCTL, and DCCTL) in which you can use the command and keywords.

*Table 289. Valid environments for the /DISPLAY MODIFY command and keywords*

| Command / Keywords | DB/DC | DBCTL | DCCTL |
|--------------------|-------|-------|-------|
| <b>/DISPLAY</b>    | X     | X     | X     |
| MODIFY             | X     | X     | X     |
| ADDS               | X     | X     | X     |
| ALL                | X     | X     | X     |
| CHNGS              | X     | X     | X     |
| DBS                | X     | X     |       |
| DELS               | X     | X     | X     |
| DMS                | X     | X     |       |
| FMS                | X     |       | X     |
| MODS               | X     | X     | X     |
| PDS                | X     | X     | X     |
| PSS                | X     | X     | X     |
| RCS                | X     |       | X     |
| TRS                | X     |       | X     |

## Syntax

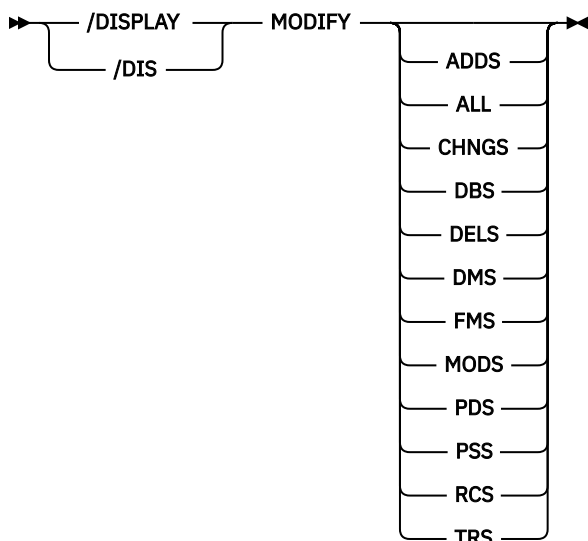

## Keywords

The following keywords are valid for the **/DISPLAY MODIFY** command:

**<blanks>**

Displays the status of online change libraries.

**ADDS**

Displays the resources to be added by online change. Each display line contains a resource type, resource name, and a status of ADDED. The resource type can be: DATABASE, DMB, FORMAT, PROGRAM, PSB, RT CODE, or TRAN.

**ALL**

Displays the status of online change libraries and any work in progress for database, program, routing code, or transaction resources to be deleted or changed by the **/MODIFY COMMIT** or the **INITIATE OLC PHASE(COMMIT)** command.

For DBCTL, transactions do not apply. For DCCTL, databases do not apply.

**CHNGS**

Displays the resources to be changed by online change. Each display line contains a resource type, resource name, and a status of CHANGED. Resource type can be: DATABASE, DMB, FORMAT, PROGRAM, PSB, RT CODE, or TRAN.

**DBS**

Displays the databases to be changed or deleted with work in progress that would prevent **/MODIFY COMMIT** from succeeding. If DBS is specified with the ADDS, CHNGS, DELS, or MODS parameters, the databases in MODBLKS to be added, changed, or deleted display. Each display line contains a resource type of DATABASE, the database name, and a status of ADDED, CHANGED, or DELETED.

**DELS**

Displays the resources to be deleted by online change. Each display line contains a resource type, resource name, and a status of DELETED. The resource type can be: DATABASE, DMB, FORMAT, PROGRAM, PSB, RT CODE, or TRAN.

**DMS**

If DMS is specified with the ADDS, CHNGS, DELS, or MODS parameters, the DMBs in ACBLIB to be added, changed, or deleted display as ADDED, CHANGED, or DELETED.

If the status of the associated database in MODBLKS is ADDED, DMS displays a DMB as ADDED. If the status of the associated database in MODBLKS is DELETED, DMS displays a DMB as DELETED.

**FMS**

If FMS is specified with the ADDS, CHNGS, DELS, or MODS parameters, the MFS formats to be added, changed, or deleted in FMTLIB display. Each display line contains a resource type of FORMAT, the format name, and a status of ADDED, CHANGED, or DELETED.

**MODS**

Displays the resource to be modified by online change, which are resources to be added, changed, and deleted. Each display line contains the resource type, resource name, and a status of ADDED, CHANGED, or DELETED. The resource type can be: DATABASE, DMB, FORMAT, PROGRAM, PSB, RT CODE, or TRAN.

**/DISPLAY MODIFY MODS** shows all of the resources to be added, changed, or deleted by **/MODIFY COMMIT**, which is equivalent to the output from **/MODIFY PREPARE** with the LTERM keyword specified.

**PDS**

Displays the programs to be changed or deleted in MODBLKS with work in progress that would prevent a **/MODIFY COMMIT** or an **INITIATE OLC PHASE(COMMIT)** command from succeeding. If PDS is specified with the ADDS, CHNGS, DELS, or MODS parameters, the programs in MODBLKS to be added, changed, or deleted display. Each display line contains a resource type of PROGRAM, the program name, and a status of ADDED, CHANGED, or DELETED.

**PSS**

If PSS is specified with the ADDS, CHNGS, DELS, or MODS parameters, the PSBs in ACBLIB to be added, changed, or deleted display as ADDED, CHANGED, or DELETED.

If the status of the associated program in MODBLKS is ADDED, PSS displays a PSB as ADDED. If the status of the associated program in MODBLKS is DELETED, PSS displays a PSB as DELETED.

### RCS

Displays the routing codes to be changed or deleted in MODBLKS with work in progress that would prevent a **/MODIFY COMMIT** or an **INITIATE OLC PHASE(COMMIT)** command from succeeding. If RCS is specified with the ADDS, CHNGS, DELS, or MODS parameters, RTCODEs in MODBLKS to be added, changed, or deleted display.

### TRS

Displays the transactions to be changed or deleted in MODBLKS with work in progress that would prevent a **/MODIFY COMMIT** or an **INITIATE OLC PHASE(COMMIT)** command from succeeding. If TRS is specified with the ADDS, CHNGS, DELS, or MODS parameters, transactions in MODBLKS to be added, changed, or deleted display.

## Usage notes

The **/DISPLAY MODIFY** command with one or more keywords (not including ALL) is only valid if IMS is in the MODIFY PREPARE state, which means that a **/MODIFY PREPARE** command or an **INITIATE OLC PHASE(PREPARE)** command completed successfully.

If IMS cannot access the global queue counts, IMS displays the GLOBAL QUEUE COUNT INTERNAL ERROR status. If IMS cannot obtain sufficient storage to query global queue counts, IMS displays the GLOBAL QUEUE COUNT STORAGE ERROR status. In either case, online change will fail if there are global queue counts for resources being changed or deleted.

For an IMS that has online change for MODBLKS disabled and no MODBLKS data sets are included in the IMS JCL, no information about active and inactive MODBLKS data sets is displayed.

## Equivalent IMS type-2 commands

The following table shows variations of the **/DISPLAY MODIFY** command and the IMS type-2 commands that perform similar functions.

Table 290. Type-2 equivalents for the **/DISPLAY MODIFY** command

| Task   | <b>/DISPLAY MODIFY</b> command | Similar IMS type-2 command                       |
|--|--------------------------------|--|
| Displays work in progress for runtime resource definitions that would cause a <b>DELETE</b> , <b>/MODIFY COMMIT</b> , <b>INITIATE OLC PHASE(COMMIT)</b> , or <b>UPDATE</b> command to change resource definitions to fail. | <b>/DISPLAY MODIFY ALL</b>     | QUERY DB NAME( <i>dbname</i> )<br>SHOW(WORK)     |
|  |                                | QUERY PGM NAME( <i>pgmname</i> )<br>SHOW(WORK)   |
|  |                                | QUERY RTC NAME( <i>rtcode</i> )<br>SHOW(WORK)    |
|  |                                | QUERY TRAN NAME( <i>tranname</i> )<br>SHOW(WORK) |

## Output fields

The online change libraries are described in the output in the following order: the word "LIBRARY", the library name, the library status displayed as A for active, I for inactive, or U for unallocated, and the data set in which the library resides. If the ACBLIB data sets are allocated by JCL, the status displayed for each library is displayed as A for active or I for inactive. It is followed by the DD names and data set names that make up the library. If the ACBLIB data sets are allocated by DFSMDA, the status of the inactive ACBLIB data sets is displayed as U for unallocated. The data set names displayed are those specified in the DFSMDA member for that ACBLIB DD statement.

A status of **\*\* NOT AVAILABLE \*\*** is displayed for ACBLIB instead of an ACBLIB data set name if managed ACBs is enabled, or if managed ACBs is not enabled and the ACBLIB data set could not be found.

Status information is displayed for the following libraries:

- IMSACBA and IMSACBB
- FORMATA and FORMATB
- MODBLKSA and MODBLKSB

The following output fields are displayed for the **/DISPLAY MODIFY** command.

#### **Resource type**

Resource type can be LIBRARY, DATABASE, PROGRAM, RTCODE, or TRAN.

#### **Resource name**

The name of the library, database, program, routing code, or transaction.

#### **Status**

Status of the resource or data set name, for a library.

The following status terms are displayed by the **/DISPLAY MODIFY** command:

#### **ACTIVE**

The routing code rcode is active.

#### **ADDED**

One of the following:

- The database, DMB, MFS format, program, PSB, Fast Path routing code (RTCODE), or transaction resource is to be added by online change.
- The DMB already exists in ACBLIB and its associated database is to be added to MODBLKS, making the database usable.
- The PSB already exists in ACBLIB and its associated program is to be added to MODBLKS, making the program usable.

#### **AREAS OPEN:**

A DEDB database has open areas. One or more lines listing the open areas follow this line.

#### **CHANGED**

One of the following:

- The database, DMB, MFS format, program, PSB, Fast Path routing code (RTCODE), or transaction resource is to be changed by online change. The prepare command has stopped queuing to transactions affected by the online change. Affected transactions are rejected from an input terminal until the online change is committed or aborted. Program-to-program switches are not rejected. Commit will fail for the resource to be changed, if it has work in progress.
- The program is not to be changed, but is associated with a PSB whose JAVA attribute is to be changed. The program is treated as if it is to be changed, because a PSB scheduling attribute is changing.
- The routing code is not to be changed, but references a PSB that is to be deleted. The routing code is treated as if it is to be changed, because it will no longer be usable.
- The transaction is not to be changed, but references a PSB that is to be deleted. The transaction is treated as if it is to be changed, because it will no longer be usable.

#### **CHANGED (DSID CHANGED)**

The area is to be changed and the data set ID (area number) is to be changed.



**Attention:** Actions must be taken to prevent damage to the area. See [The online change function, DEDBs, and Availability of IFP and MPP Regions \(Database Administration\)](#).

#### **CHANGED (TIMESTAMP ONLY)**

The PSB is to be changed, but only the time stamp is to be changed. The PSB is considered to be affected by the online change, even though nothing is really changing.

**CONVERSATION TERM/USER**

The transaction to be changed or deleted or the transaction referencing a program or database to be changed or deleted is in conversation. The terminal originating the conversational transaction and the conversation ID are also displayed.

The terminal information displayed is:

- nodename for VTAM terminals
- nodename and username if an ETO user is signed on to the node
- username for ETO users that signed off while in conversation
- lin#-pte# (line and pterm number) for IMS-supported terminals
- 1-SC for the system console

**CONVERSATION LUNAME**

An APPC logical unit originated the conversational transaction that is to be changed or deleted or that references a program or database to be changed or deleted. The LUNAME and conversation ID are also displayed. The LUNAME information is in the format of luname, or networkid.luname, if networkid-qualified.

**CONVERSATION TMEM/TPIP**

An OTMA tmember/tpipe originated a conversational transaction that is to be changed or deleted or that references a program or database to be changed or deleted. The tmember, tpipe and conversation ID are also displayed. The tmember and tpipe information is in the format of tmember.tpipe, where the tmember name can be up to 8 characters.

**DATABASE IN USE**

The database is in use by one or more active regions referencing the database.

**/DBD ACTIVE**

A **/DBDUMP** command is in progress for a database to be changed or deleted.

**/DBR ACTIVE**

A **/DBRECOVERY** command is in progress for a database to be changed or deleted.

**/DBR OR /STOP IN PROGRESS**

A **/DBRECOVERY** command or **/STOP** command is in progress for a DEDB database.

**DBR NEEDED FOR PARTITION**

A **/DBRECOVERY** command must be issued for the DB partition before the database can be changed or deleted by online change

**DELETED**

One of the following:

- The database, DMB, MFS format, program, PSB, Fast Path routing code (RTCODE), or transaction resource is to be deleted by online change. The prepare command has stopped queuing to transactions affected by the online change. Affected transactions are rejected from an input terminal until the online change is committed or aborted. Program-to-program switches are not rejected. Commit will fail for the resource to be deleted, if it has work in progress.
- The DMB is not to be changed, but references a database that is to be deleted. The DMB is treated as if it is to be deleted, because IMS will no longer have any information about the DMB.
- The PSB is not to be changed, but references a program that is to be deleted. The PSB is treated as if it is to be deleted, because IMS will no longer have any information about the PSB.

**ELIGIBLE FOR SCHEDULING**

The transaction is eligible for scheduling and cannot be deleted or changed by online change. The transaction itself is being changed or deleted, or the program it references is being changed. Stop the transaction before attempting another online change commit. If the only thing being changed is the PSB associated with the program that the transaction references, the transaction might not need to be stopped.

**IN USE**

Queuing is in progress for this transaction (either terminal input or program-to-program switch).



**NOT CHANGED (DMB CHANGED ONLY)**

The PSB is not to be changed, but references a DMB that is to be changed or deleted. The PSB is considered to be affected by the online change, where commit will fail for work in progress.

**NOT CHANGED (PDIR/PSB CHANGE ONLY)**

One of the following:

- The routing code is not to be changed, but references a PDIR or PSB that is to be changed. The routing code is considered to be affected by the online change, where commit will fail for work in progress.
- The transaction is not to be changed, but references a PSB that is to be changed. This status does not apply to PSB attribute changes that affect scheduling, such as the JAVA attribute. The transaction is not affected by online change, so commit will succeed even if there is work in progress.

**PSB SCHEDULED**

A program referencing a database to be changed or deleted is scheduled.

**QUEUING *nn***

Messages are queued to the transaction or program; *nn* is the number of messages queued. Global queue counts represent the number of messages on the coupling facility list structure for the transaction or program.

**Q STRUCTURE IS UNAVAILABLE**

The queue structure is unavailable. IMS is unable to check the global queue count for transactions to be added, changed, or deleted. Commit is not permitted to proceed. The structure may be unavailable for one of the following reasons:

- CQS is unavailable.
- The MSGQ structure failed and it has not been rebuilt yet.
- CQS lost connectivity to the MSGQ structure.

**RANDOMIZER: *rndmname***

A DEDB database that has no work in progress lists the randomizer name (*rndmname*). The randomizer display lines are information only, not work in progress that would prevent online change commit from succeeding.

This line is followed by a line with the randomizer name and status of LOADED or NOT LOADED.

If the randomizer is shared by one or more DEDBs, another line is displayed with 'DEDBS SHARING RANDOMIZER:' followed by the randomizer name. Online change will not delete a randomizer that is shared by other DEDBs. This line is followed by one line for each DEDB sharing the same randomizer.

**RECOVERY IN PROGRESS**

A **/RECOVER START** command is in progress to recover one or more databases with the database recovery service.

**SAME (DSID CHANGED)**

The area is not to be changed, but the data set ID (area number) is to be changed.



**Attention:** Actions must be taken to prevent damage to the area. See [The online change function, DEDBs, and Availability of IFP and MPP Regions \(Database Administration\)](#).

**SCHEDULED**

The named resource (a transaction or program to be changed or deleted, or a program referencing a database to be changed or deleted) is scheduled.

**SUSPENDED**

The transaction to be changed or deleted is on the suspend queue.

Work in progress for resources to be deleted or changed causes the **/MODIFY COMMIT** command to fail. You must wait for the work in progress to complete, or force it to complete (for example, by issuing a command), before issuing **/MODIFY COMMIT**. The following table lists the resource type, resource name,

and the status displays for work in progress that would prevent the **/MODIFY COMMIT** command from completing successfully:

*Table 291. Work in progress for resources that prevent a successful /MODIFY COMMIT*

| Resource type | Resource name | Status   |
|---------------|---------------|--|
| DATABASE      | dbname        | AREAS OPEN:<br>/DBD ACTIVE<br>/DBR ACTIVE<br>/DBR OR /STOP IN PROGRESS<br>DATABASE IN USE<br>DBR NEEDED FOR PARTITION<br>nnnn PSB SCHEDULED<br>RANDOMIZER: rndmname<br>RECOVERY IN PROGRESS  |
| AREA          | areaname      | OPEN<br>RECOVERY IN PROGRESS   |
| PROGRAM       | pgmname       | SCHEDULED<br>QUEUING nn<br>GLOBAL QUEUE COUNT INTERNAL ERROR<br>GLOBAL QUEUE COUNT STORAGE ERROR   |
| RTCODE        | rtcode        | ACTIVE   |
| TRAN          | trancode      | IN USE<br>QUEUING nn<br>SCHEDULED<br>SUSPENDED<br>CONVERSATION TERM/USER<br>nodename ID= nnnn<br>nodename username ID= nnnn<br>username ID= nnnn<br>lin#-pte# ID= nnnn<br>1- SC ID= nnnn<br>GLOBAL QUEUE COUNT INTERNAL ERROR<br>GLOBAL QUEUE COUNT STORAGE ERROR<br>ELIGIBLE FOR SCHEDULING |

In a shared-queues environment, **/DISPLAY MODIFY** only shows local work in progress, except for the TRAN QUEUING status and the PROGRAM QUEUING status, for which this command shows the sum of local and global queue counts. That is, **/DISPLAY MODIFY** does not show whether there is work in progress for other IMS subsystems sharing the message queues. If the **/DISPLAY MODIFY** command shows no work in progress for the IMS subsystem which the command was issued, a **/MODIFY COMMIT** command can be issued for that IMS subsystem.

### Examples

The following are examples of the **/DISPLAY MODIFY** command.

#### **Example 1 for /DISPLAY MODIFY command**

In these examples for **/DISPLAY MODIFY**, **/MODIFY PREPARE** has already succeeded.

Entry ET:

```
/DISPLAY MODIFY ALL
```

Response ET:

```
LIBRARY IMSACBA (A) OLC.ACBLIB.ALL
LIBRARY FORMATA (I) IMSQA.FMT1
LIBRARY MODBLKSA (A) I41RTS42.CMODBLKS
LIBRARY IMSACBB (I) OLC.ACBLIB.ALL
LIBRARY FORMATB (A) IMSQA.FMT1
LIBRARY MODBLKSB (I) I41RTS42.CMODBLK1
DATABASE OLCDB088 /DBR ACTIVE
DATABASE OLCDB101 PSB SCHEDULED
PROGRAM OLCPB021 SCHEDULED
PROGRAM OLCPB109 SCHEDULED
RTCODE OLCRC056 ACTIVE
TRAN OLCBT105 QUEUING 1
TRAN CDEBTRN5 CONVERSATION TERM/USER 4- 2 ID= 0009
TRAN OLCBT109 SCHEDULED
TRAN CDEBTRN8 CONVERSATION TERM/USER L3270D ID= 0002
TRAN OLCBT111 QUEUING 5
TRAN CDEBTRN2 CONVERSATION TERM/USER DYNT0001 IMSUS01 ID= 0005
TRAN CDEBTRN3 CONVERSATION TERM/USER 12- 1 ID= 0008
TRAN CDEBTRN1 CONVERSATION TERM/USER IMSUS12 ID= 0001
DISPLAY MODIFY COMPLETE
*93336/093025*
```

Entry ET:

```
/DISPLAY MODIFY DBS
```

Response ET:

```
DATABASE CALENDER AREAS OPEN:
AREA FEBRUARY
AREA APRIL
AREA JULY
AREA AUGUST
AREA SEPTEMBER
AREA OCTOBER
AREA DECEMBER
DATABASE CALENDER RANDOMIZER: RMOD3
DEDBS SHARING RANDOMIZER: RMOD3
DATABASE DEDBJN21 RANDOMIZER: RMOD3
RMOD3 NOT LOADED
DATABASE DEDBJN22 RANDOMIZER: RMOD5
RMOD5 NOT LOADED
DISPLAY MODIFY COMPLETE *95299/161529*
```

Entry ET:

```
/DISPLAY MODIFY TRS
```

Response ET:

```
TRAN OLCFT112 QUEUING 2
TRAN OLCFT115 QUEUING 23
PROGRAM OLCFP115 QUEUING 1
TRAN CDEBTRN8 GLOBAL QUEUE COUNT INTERNAL ERROR
TRAN OLCFT116 QUEUING 6
DISPLAY MODIFY COMPLETE *96193/135935*
```

Explanation: Work is in progress that will cause online change to fail, because several transactions and a FP program have a global queue count on the shared queues. The global queue count for transaction CDEBTRN8 could not be determined because of an internal error.

**Example 2 for /DISPLAY MODIFY command**

Entry ET:

```
/DISPLAY MODIFY MODS
```

Response ET:

```
DFS000I    FORMAT    0C01_FF02A  _0  ADDED
DFS000I    FORMAT    0C01_FF02B  _0  ADDED
DFS000I    FORMAT    0C7F_FN01A  _0  CHANGED
DFS000I    FORMAT    0C7F_FN01B  _0  CHANGED
DFS000I    FORMAT    0C7F_FN01C  _0  CHANGED
DFS000I    FORMAT    0C7F_FF04A  _0  DELETED
DFS000I    FORMAT    MF04E        DELETED
DFS000I    DATABASE  OLCDB101     ADDED
DFS000I    DATABASE  OLCDB102     ADDED
DFS000I    DATABASE  OLCDB103     ADDED
DFS000I    DATABASE  OLCDB104     ADDED
DFS000I    DATABASE  OLCDB157     ADDED
DFS000I    DATABASE  OLCDB111     DELETED
DFS000I    DATABASE  OLCDB159     DELETED
DFS000I    DATABASE  OLCDI105     DELETED
DFS000I    DATABASE  OLCDI106     DELETED
DFS000I    DMB       OLCDB101     ADDED
DFS000I    DMB       OLCDB102     ADDED
DFS000I    DMB       DEDBJN24     CHANGED
DFS000I    AREA     DB24A000     CHANGED
DFS000I    DMB       OLCDB105     DELETED
DFS000I    PROGRAM  OLCFP107     ADDED
DFS000I    PROGRAM  OLCFP108     ADDED
DFS000I    PROGRAM  OLCPB101     ADDED
DFS000I    PROGRAM  OLCFP109     CHANGED
DFS000I    PROGRAM  OLCFP110     CHANGED
DFS000I    PROGRAM  OLCFP111     CHANGED
DFS000I    PROGRAM  OLCPB105     DELETED
DFS000I    PROGRAM  OLCPB106     DELETED
DFS000I    PSB      OLCFP107     ADDED
DFS000I    PSB      OLCFP108     ADDED
DFS000I    PSB      CDEBS       CHANGED
DFS000I    PSB      OLCPB105     DELETED
DFS000I    PSB      OLCPB106     DELETED
DFS000I    RT CODE  OLCFT108     ADDED
DFS000I    RT CODE  OLCFR119     CHANGED
DFS000I    RT CODE  OLCFR117     DELETED
DFS000I    TRAN     OLCFT108     ADDED
DFS000I    TRAN     OLCTBG17     ADDED
DFS000I    TRAN     CDEBTRNA     CHANGED
DFS000I    TRAN     CDEBTRN1     CHANGED
DFS000I    TRAN     CONV31X      DELETED
DFS000I    DISPLAY  MODIFY COMPLETE *98356/094452*   SYS3
```

Explanation: Displays resources to be modified (added, changed, or deleted) by online change.

### **Example 3 for /DISPLAY MODIFY command**

Entry ET:

```
/DISPLAY MODIFY ALL
```

Response ET:

```
LIBRARY IMSACBA (A) IMSTESTG.DELTALIB
                (A) IMSTESTL.TNUC2
                (A) IMSTESTG.IMS61RC.ACBLIB
LIBRARY FORMATA (A) IMSTESTG.IMS61R.ACBLIB
                (A) IMSTESTG.MFS.OVERRIDE.FORM
                (A) IMSTESTG.MFS.FORMAT
                (A) IMSQA.FMT1
LIBRARY MODBLKSA (A) IMSBLD.I61RTS25.CMODBLKS
LIBRARY IMSACBB (I) IMSTESTG.DELTALIB
                (I) IMSTESTL.TNUC3
                (I) IMSTESTG.IMS61RC.ACBLIB
                (I) IMSTESTG.IMS61R.ACBLIB
LIBRARY FORMATB (I) IMSTESTG.MFS.OVERRIDE.FORM
                (I) IMSTESTG.MFS.FORMAT
                (I) IMSQA.FMT1
LIBRARY MODBLKSB (I) IMSBLD.I61RTS25.CMODBLKS
DATABASE DEDBJN21 RANDOMIZER: RMOD3 (1)
```

```

RMOD3    LOADED                                (2)
DEDBS    SHARING                                RANDOMIZER: RMOD3    (3)
          DEDB DEDBJN22
          DEDB DEDBJN23
          DEDB DEDB3301
DATABASE DEDBJN22                                RANDOMIZER: RMOD3
RMOD3    NOT                                    LOADED
DEDBS    SHARING                                RANDOMIZER: RMOD3
          DEDB DEDBJN21
          DEDB DEDBJN23
          DEDB DEDB3301
DATABASE DEDBJN23                                RANDOMIZER: RMOD3
RMOD3    LOADED
DEDBS    SHARING                                RANDOMIZER: RMOD3
          DEDB DEDBJN21
          DEDB DEDBJN22
          DEDB DEDB3301
NO WORK PENDING *99328/110535*   SYS3

```

Explanation: In this example:

- DEDB databases DEDBJN21, DEDBJN22, and DEDBJN23 have undergone Online Change.
- After a database line for DEDBS displays, a line follows containing randomizer status (loaded or not loaded).
- After the randomizer status displays, a line might follow containing DEDBS SHARING RANDOMIZER; this line is followed by DEDB lines listing the DEDBs that share the randomizer.

**Example 6 for /DISPLAY MODIFY command**

Entry ET:

```
/DISPLAY MODIFY ALL
```

Response ET:

```

LIBRARY IMSACBA (A) IMSTESTG.DELTA1
              (A) IMSTESTG.IMS10AC.ACBLIB1
              (A) IMSTESTG.IMS10A.ACBLIB1
LIBRARY FORMATA (A) IMSTESTG.MFS.FORMAT1
              (A) IMSTESTG.MFS.FORMAT2
              (A) IMSQA.FMT1
LIBRARY MODBLKSA (A) IMSBLD.I10ATS17.COMBLKS1
LIBRARY IMSACBB (U) IMSTESTG.DELTA2
              (U) IMSTESTG.IMS10AC.ACBLIB2
              (U) IMSTESTG.IMS10A.ACBLIB2
LIBRARY FORMATB (I) IMSTESTG.MFS.FORMAT3
              (I) IMSTESTG.MFS.FORMAT4
              (I) IMSQA.FMT1
LIBRARY MODBLKSB (I) IMSBLD.I10ATS17.COMBLKS2
DISPLAY MODIFY COMPLETE *07003/110121*   SYS3

```

TSO SPOC output:

```

MBRNAME  MESSAGES
-----
SYS3     LIBRARY  IMSACBA  (A)  IMSTESTG.DELTA1
SYS3     (A)  IMSTESTG.IMS10AC.ACBLIB1
SYS3     (A)  IMSTESTG.IMS10A.ACBLIB1
SYS3     LIBRARY  FORMATA  (A)  IMSTESTG.MFS.OVERRIDE.FORMAT1
SYS3     (A)  IMSTESTG.MFS.FORMAT1
SYS3     (A)  IMSQA.FMT1
SYS3     LIBRARY  MODBLKSA (A)  IMSBLD.I10ATS17.COMBLKS1
SYS3     LIBRARY  IMSACBB  (U)  IMSTESTG.DELTA2
SYS3     (U)  IMSTESTG.IMS10AC.ACBLIB2
SYS3     (U)  IMSTESTG.IMS10A.ACBLIB2
SYS3     LIBRARY  FORMATB  (I)  IMSTESTG.MFS.OVERRIDE.FORMAT2
SYS3     (I)  IMSTESTG.MFS.FORMAT2
SYS3     (I)  IMSQA.FMT2
SYS3     LIBRARY  MODBLKSB (I)  IMSBLD.I10ATS17.COMBLKS2
SYS3     DISPLAY MODIFY COMPLETE *07003/114249*

```

Explanation: In this example, IMSACBA is the active ACBLIB; IMSACBB is the inactive ACBLIB. The inactive ACBLIB data sets are displayed even though they are not allocated. The "U" indicates that they are unallocated.

**Example 7 for /DISPLAY MODIFY command**

Entry ET:

```
/DISPLAY MODIFY ALL
```

Response ET:

```
DFS000I    LIBRARY  IMSACBA  (A)  IMSTESTG.DELTALIB
DFS000I    LIBRARY  IMSACBA  (A)  IMSTESTG.IMS10AC.ACBLIB
DFS000I    LIBRARY  IMSACBA  (A)  IMSTESTG.IMS10A.ACBLIB
DFS000I    LIBRARY  FORMATA  (A)  IMSTESTG.MFS.FORMAT1
DFS000I    LIBRARY  FORMATA  (A)  IMSTESTG.MFS.FORMAT2
DFS000I    LIBRARY  FORMATA  (A)  IMSQA.FMT1
DFS000I    LIBRARY  MODBLKSA (A)  IMSBLD.I10ATS17.COMBLKS1
DFS000I    LIBRARY  IMSACBB  ( )  NO DFSMDA MEMBER
DFS000I    LIBRARY  FORMATB  (I)  IMSTESTG.MFS.FORMAT3
DFS000I    LIBRARY  FORMATB  (I)  IMSTESTG.MFS.FORMAT4
DFS000I    LIBRARY  FORMATB  (I)  IMSQA.FMT1
DFS000I    LIBRARY  MODBLKSB (I)  IMSBLD.I10ATS17.COMBLKS1
DFS000I    DISPLAY  MODIFY  COMPLETE *07003/110121*  SYS3
```

Explanation: In this example, IMSACBA is the active ACBLIB; IMSACBB is the inactive ACBLIB. There is no DFSMDA member for the inactive ACBLIB data sets. The data set name field contains "NO DFSMDA MEMBER". The status field is left blank.

**Example 8 for /DISPLAY MODIFY command**

The following example shows an online HALDB database, DBVHDJ05, that is currently being altered.

Entry ET:

```
/DISPLAY MODIFY DBS
```

TSO SPOC output:

```
MbrName  Messages
-----  -
IMS1     DATABASE DBOHIDK5      DBR NEEDED FOR PARTITION
IMS1     DATABASE DBVHDJ05     ALTER INCOMPLETE
IMS1     DATABASE DBVHDJ05     4 PSBS SCHEDULED
IMS1     DATABASE DBVHDJ05     DATABASE IN USE
```

**Example 9 for /DISPLAY MODIFY command**

TSO SPOC input:

```
/DISPLAY MODIFY ALL
```

TSO SPOC output:

```
Log for: /DISPLAY MODIFY ALL.
IMSpIex . . . . . : PLEX1
Routing . . . . . :
Start Time. . . . : 2019.296 14:15:32.90
Stop Time . . . . : 2019.296 14:15:32.91
Return code . . . : 00000000
Reason code . . . : 00000000
Reason text . . . :
Command master. . : IMS2

MbrName  Messages
-----  -
IMS2     Y01 LIBRARY  IMSACBA  (A)  ** NOT AVAILABLE **
IMS2     Y01 LIBRARY  FORMATA  (A)  IMSTESTG.MFS.OVERRIDE.FORMAT
IMS2     Y01 LIBRARY  FORMATA  (A)  IMSTESTG.MFS.FORMAT
IMS2     Y01 LIBRARY  FORMATA  (A)  IMSTESTG.IMSQA.FMT1
IMS2     Y01 LIBRARY  MODBLKSA (A)  IMSBLD.I15RTSMM.COMBLKS1
```

```

IMS2      Y01 LIBRARY  IMSACBB  (U)  ** NOT AVAILABLE **
IMS2      Y01 LIBRARY  FORMATB  (I)  IMSTESTG.MFS.OVERRIDE.FORMAT
IMS2      Y01                (I)  IMSTESTG.MFS.FORMAT
IMS2      Y01                (I)  IMSTESTG.IMSQA.FMT1
IMS2      Y01 LIBRARY  MODBLKSB (I)  IMSBLD.I15RTSMM.COMBLKS1
IMS2      Y03 DISPLAY  MODIFY COMPLETE *19296/141532*
IMS1      Y01 LIBRARY  IMSACBA  (A)  ** NOT AVAILABLE **
IMS1      Y01 LIBRARY  FORMATA  (A)  IMSTESTG.MFS.OVERRIDE.FORMAT
IMS1      Y01                (A)  IMSTESTG.MFS.FORMAT
IMS1      Y01                (A)  IMSTESTG.IMSQA.FMT1
IMS1      Y01 LIBRARY  MODBLKSA (A)  IMSBLD.I15RTSMM.COMBLKS1
IMS1      Y01 LIBRARY  IMSACBB  (U)  ** NOT AVAILABLE **
IMS1      Y01 LIBRARY  FORMATB  (I)  IMSTESTG.MFS.OVERRIDE.FORMAT
IMS1      Y01                (I)  IMSTESTG.MFS.FORMAT
IMS1      Y01                (I)  IMSTESTG.IMSQA.FMT1
IMS1      Y01 LIBRARY  MODBLKSB (I)  IMSBLD.I15RTSMM.COMBLKS1
IMS1      Y03 DISPLAY  MODIFY COMPLETE *19296/141532*

```

Explanation: This is an IMSplex with 2 IMSs: IMS1 and IMS2. The **/DISPLAY MODIFY** command is issued to display the active and inactive ACBLIB, FMTLIB, and MODBLKS data sets. Managed ACBs is enabled, so the ACBLIB is displayed as **\*\* NOT AVAILABLE \*\*** even if ACBLIB DD cards still exist in the IMS JCL because ACBLIBs are not used in a managed ACBs environment. When **/DISPLAY** commands are issued on the TSO SPOC, the output also includes the DISPLAY MACRO format ID, which maps the output.

### Related tasks

The online change function, DEDBs, and Availability of IFP and MPP Regions (Database Administration)

### Related reference

[“Status and attributes for the /DISPLAY command” on page 501](#)

A list of the attributes and status shown in the **/DISPLAY** command are described in the following table.

[QUERY DB command \(Commands\)](#)

[QUERY PGM command \(Commands\)](#)

[QUERY RTC command \(Commands\)](#)

[QUERY TRAN command \(Commands\)](#)

## **/DISPLAY MSNAME** command

Use the **/DISPLAY MSNAME** command to display the queue counts for the specified logical link path. Generic parameters are supported for the MSNAME keyword.

Subsections:

- [“Environment” on page 603](#)
- [“Syntax” on page 604](#)
- [“Keywords” on page 604](#)
- [“Usage notes” on page 604](#)
- [“Examples” on page 604](#)

### Environment

The following table lists the environments (DB/DC, DBCTL, and DCCTL) in which you can use the command and keywords.

*Table 292. Valid environments for the /DISPLAY MSNAME command and keywords*

| Command / Keywords | DB/DC | DBCTL | DCCTL |
|--------------------|-------|-------|-------|
| <b>/DISPLAY</b>    | X     | X     | X     |
| MSNAME             | X     |       | X     |
| QCNT               | X     |       | X     |

## Syntax

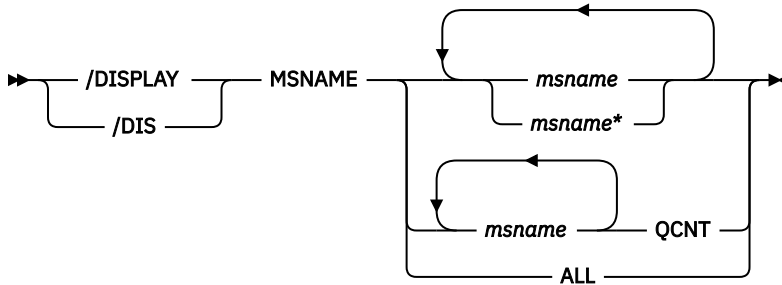

## Keywords

The following keyword can be specified for the **/DISPLAY MSNAME** command:

### QCNT

Specifies that global queue count information is to be displayed. If QCNT is not specified, local queue counts are displayed; when it is specified, no local queue counts are displayed.

This count represents the message counts of messages that can be processed by the IMS system where the command is issued. This count includes messages that can be processed by any IMS system (messages with no affinity), plus messages that can be processed by the IMS system where the command is issued (messages with an affinity to the IMS system that issued the command).

This keyword is valid only in a shared-queues environment.

## Usage notes

In a shared-queues environment, use the QCNT keyword to obtain the current message queue counts on the shared queues structure. The local queue counts (ENQCT, DEQCT, and QCT) value that is returned on this command when the QCNT keyword is not specified represents the messages being processed by the IMS system where this command is issued. Do not use local queue counts for queue evaluation purposes.

## Examples

Entry ET:

```
/DISPLAY MSNAME ALL
```

Response ET:

| MSNAME         | ENQCT | DEQCT | QCT |
|----------------|-------|-------|-----|
| SYSTEM2A       | 0     | 0     | 0   |
| SYSTEM2B       | 0     | 0     | 0   |
| FRESNO         | 0     | 0     | 0   |
| BOSTON         | 0     | 0     | 0   |
| ALBANY         | 0     | 0     | 0   |
| TEST1          | 0     | 0     | 0   |
| *91350/053859* |       |       |     |

Entry ET:

```
/DISPLAY MSNAME ALL
```

Response ET:

| MSNAME   | ENQCT | DEQCT | QCT | IMS1    | IMS1 |
|----------|-------|-------|-----|---------|------|
| LINK23B4 | 0     | 0     | 0   | DYNAMIC | IMS1 |
| LINK12V1 | 0     | 0     | 0   | IMS1    |      |



```

LINK23U2      0      0      0  DYNAMIC  IMS1
ELINK211     0      0      0  DYNAMIC  IMS1
LINK13B3     0      0      0      IMS1
LINK13V      0      0      0      IMS1
LINK12V      0      0      0      IMS1
LINK13C2     0      0      0      IMS1
LINK13X      0      0      0      IMS1
LINK12V2     0      0      0      IMS1
LINK13M2     0      0      0      IMS1
LINK13V2     0      0      0      IMS1
ELINK124     0      0      0      IMS1
LINK23V1     0      0      0  DYNAMIC  IMS1
LINK12B1     0      0      0      IMS1
LINK12B2     0      0      0      IMS1
LINK12Y      0      0      0      IMS1
ELINK120     0      0      0      IMS1
LINK13B4     0      0      0      IMS1
LINK21V3     0      0      0  DYNAMIC  IMS1
ELINK1MS     0      0      0      IMS1
LINK12M1     0      0      0      IMS1
LINK23V      0      0      0  DYNAMIC  IMS1
LINK13U2     0      0      0      IMS1
LINK23B3     0      0      0  DYNAMIC  IMS1
ELINK224     0      0      0  DYNAMIC  IMS1
LINK23X      0      0      0  DYNAMIC  IMS1
LINK23V2     0      0      0  DYNAMIC  IMS1
ELINK121     0      0      0      IMS1
LINK23C2     0      0      0  DYNAMIC  IMS1
LINK12U1     0      0      0      IMS1
LINK23M2     0      0      0  DYNAMIC  IMS1
ELINK122     0      0      0      IMS1
ELINK222     0      0      0  DYNAMIC  IMS1
LINK12C1     0      0      0      IMS1
LINK13V1     0      0      0      IMS1
ELINK123     0      0      0      IMS1
PTH3TSTB    0      0      0      IMS1
*97258/175636*

```

## **/DISPLAY NODE command**

The **/DISPLAY NODE** command, when followed by a valid node name or ALL, displays status, queue counts, and number of messages sent to and received from the specified node.

Subsections:

- [“Environment” on page 605](#)
- [“Syntax” on page 606](#)
- [“Keywords” on page 607](#)
- [“Usage notes” on page 609](#)
- [“Equivalent IMS type-2 commands” on page 610](#)
- [“Output fields” on page 610](#)
- [“Examples” on page 611](#)

### **Environment**

The following table lists the environments (DB/DC, DBCTL, and DCCTL) in which you can use the command and keywords.

*Table 293. Valid environments for the /DISPLAY NODE command and keywords*

| <b>Command / Keywords</b> | <b>DB/DC</b> | <b>DBCTL</b> | <b>DCCTL</b> |
|---------------------------|--------------|--------------|--------------|
| <b>/DISPLAY</b>           | X            | X            | X            |
| EMHQ                      | X            |              | X            |
| NODE                      | X            |              | X            |

Table 293. Valid environments for the /DISPLAY NODE command and keywords (continued)

| Command / Keywords | DB/DC | DBCTL | DCCTL |
|--------------------|-------|-------|-------|
| QCNT               | X     |       | X     |
| RECOVERY           | X     | X     |       |
| USER               | X     |       | X     |

## Syntax

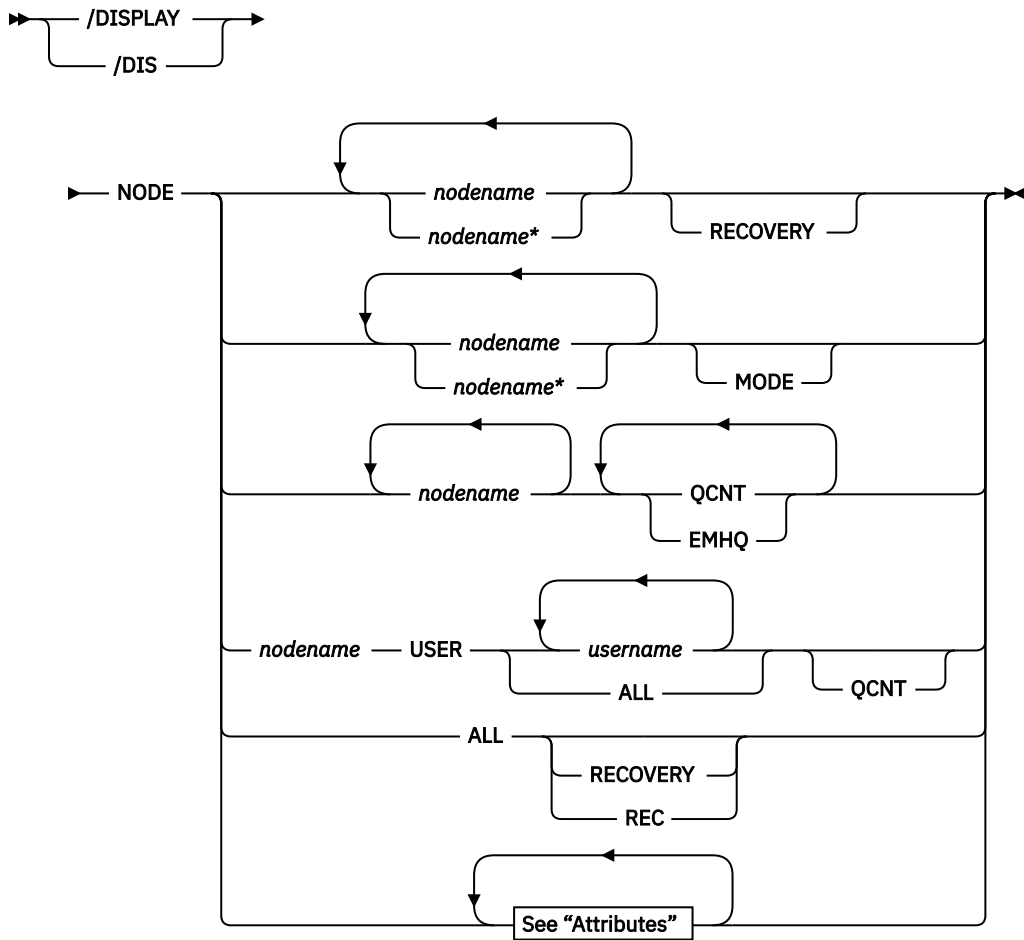

## Attributes

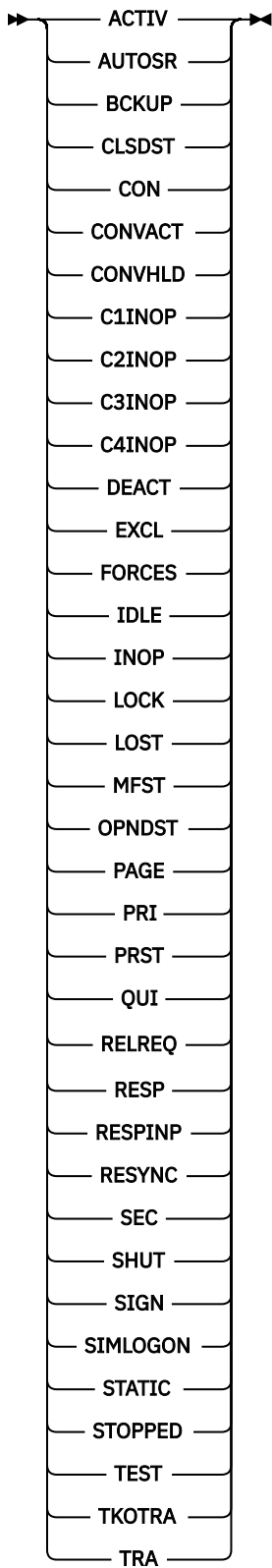

## Keywords

The following keywords can be specified for the **/DISPLAY NODE** command:

## MODE

Displays the mode table names that are associated with the specified nodes.

## EMHQ

Specifies that global queue count information on the Expedited Message Handler Queues (EMHQ) displays when both EMHQ and QCNT are specified. If EMHQ is specified, QCNT must also be specified. This keyword is valid only in a shared-queues environment.

## QCNT

Specifies that global queue count information is to be displayed. If QCNT is not specified, local queue counts are displayed; when it is specified, no local queue counts are displayed. If QCNT is specified and EMHQ is not, global queue count information on the shared message queues (MSGQ) is displayed.

This count represents the message counts of messages that can be processed by the IMS system where the command is issued. This count includes messages that can be processed by any IMS system (messages with no affinity), plus messages that can be processed by the IMS system where the command is issued (messages with an affinity to the IMS system that issued the command).

IMS does not check if the specified name is a valid LTERM in the IMS subsystem on which the command is entered.

This command does not display queue counts for Fast Path output messages for the NODE unless EMHQ and QCNT are specified.

This keyword is valid only in a shared-queues environment.

## RECOVERY

The **/DISPLAY NODE|USER RECOVERY** command can be used to display the recovery values that pertain to the node or user. The recovery values may be displayed from the local control blocks, if available, or from values saved for the node or user in the Resource Manager, if resource information is being kept in Resource Manager, and the node or user is defined to have its status kept in Resource Manager.

## Attributes

Reserved parameters for the **/DISPLAY NODE** command and cannot be used to name nodes.

Attributes listed in [“Keywords and reserved parameters” on page 535](#) for the **/DISPLAY AREA** command can be used with the NODE keyword. Nodes are selected for display based on the attribute or attributes specified. The attribute display format is the same as the standard NODE display. Attributes usually correspond to the conditions displayed for nodes. Any exceptions are flagged in the following list.

For example, **/DISPLAY NODE TRACE** displays all nodes that are currently being traced. Following is a list of the attributes that can be specified with the NODE keyword.

- ACTIV
- AUTOSR (Corresponds to the NODE conditions ASR)
- BCKUP
- CLSDST
- CON
- CONVACT (Corresponds to the NODE condition CONV-ACT)
- CONVHLD (Corresponds to the NODE condition CONV-HLD)
- C1INOP
- C2INOP
- C3INOP
- C4INOP
- DEACT
- EXCL
- FORCES (Corresponds to the NODE condition FORCE)

- IDLE
- INOP
- LOCK
- LOST
- MFST
- OPNDST
- PAGE
- PRI
- PRST
- QUI
- RECOVER
- RELREQ
- RESP
- RESPINP
- RESYNC
- SEC
- SHUT
- SIGN
- SIMLOGON
- STATIC
- STOPPED
- TEST
- TKOTRA
- TRA

**Note:** The **/DISPLAY NODE RESPINP** command returns all nodes that have RESP-INP and RESP-INP-FP status.

N/A is displayed by the **/DISPLAY NODE ALL MODE** command for VTAM 3270 nodes.

## Usage notes

In a shared-queues environment, use the QCNT keyword to obtain the current message queue counts on the shared queues structure. The local queue counts (ENQCT, DEQCT, and QCT) value that is returned on this command when the QCNT keyword is not specified represents the messages being processed by the IMS system where this command is issued. Do not use local queue counts for queue evaluation purposes.

When using ISC, the output for a parallel-session node shows one line of information for each session of the node whether the node is active or not and whether logical terminals are assigned or not. If a session is active, the user identifier (preceded by a dash) and the status and queue counts are displayed on a subsequent line. The **/DISPLAY NODE** command displays queue counts up to a maximum of 32 KB. The queue count for the **/DISPLAY NODE** command is reset to zero when sessions are not active, or when a signed-on user issues **/SIGN OFF**.

The USER keyword is valid for ISC nodes with users or dynamic nodes with signed on users. The NODE parameter can be generic where the USER keyword is not present. The generic parameter specifies nodes that already exist. A status of STATIC is displayed for nodes defined to IMS by way of system definition. STATIC is also supported as an attribute parameter. Static nodes are used with the **/DISPLAY NODE** command in the same way that dynamic nodes are used.

The **/DISPLAY NODE** command shows signed on users, where the user ID follows the status SIGN in parentheses.

**Restrictions for using NODE and USER parameters together:**

- Commands with the NODE USER keyword pair are valid only if:
  - The USER is signed on to the NODE
  - In an ISC environment, the USER is allocated to the NODE
  - The nodes and users already exist
- **/DISPLAY NODE USER** commands are valid for ISC and non-ISC nodes and users.

**Equivalent IMS type-2 commands**

The following table shows variations of the **/DISPLAY NODE** command and the IMS type-2 commands that perform similar functions.

*Table 294. Type-2 equivalents for the /DISPLAY NODE command*

| <b>Task</b>   | <b>/DISPLAY NODE command</b>  | <b>Similar IMS type-2 command</b> |
|---|---|-----------------------------------|
| Displays VTAM connection identifier (CID).                                  | <code>/DISPLAY NODE node</code>   | QUERY NODE SHOW(CID)              |
| Displays send/receive message counts.                                       | <code>/DISPLAY NODE node</code>   | QUERY NODE SHOW(COUNT)            |
| Displays preset destination.  | <code>/DISPLAY NODE node</code>   | QUERY NODE SHOW(PRESET)           |
| Displays queue count.   | <code>/DISPLAY NODE node</code><br><code>/DISPLAY NODE node QCNT</code> | QUERY NODE SHOW(QCNT)             |
| Displays status for a particular node.                                      | <code>/DISPLAY NODE node</code>   | QUERY NODE SHOW(STATUS)           |
| Displays terminal type.   | <code>/DISPLAY NODE node</code>   | QUERY NODE SHOW(TYPE)             |
| Displays user ID.   | <code>/DISPLAY NODE node</code>   | QUERY NODE SHOW(USERID)           |
| Displays user.  | <code>/DISPLAY NODE node</code>   | QUERY NODE SHOW(USER)             |
| Displays VTAM mode table names.   | <code>/DISPLAY NODE node MODE</code>                                    | QUERY NODE SHOW(MODETBL)          |
| Displays message queue count in the Expedited Message Handler (EMH) queues. | <code>/DISPLAY NODE node QCNT EMHQ</code>                               | QUERY NODE SHOW(EMHQ)             |
| Displays owner IMSID in RM resource structure.                              | <code>/DISPLAY NODE node RECOVERY</code>                                | QUERY NODE SHOW(OWNER)            |
| Displays status recovery information.                                       | <code>/DISPLAY NODE node RECOVERY</code>                                | QUERY NODE SHOW(RECOVERY)         |

**Output fields**

The output fields displayed for the **/DISPLAY NODE** command include the following:

**NODE-USR**

Node name and user identifier.

**TYPE**

Type of node.

**DEF MODETBL**

Default mode table name set by way of system definition or logon descriptor or **/CHANGE** command. This name can be overridden using the **/OPNDST** command or the LOGON exit for non-IMS session initiations.

**ACT MODETBL**

Mode table name actually used to initiate the session. This name is only displayed while the session is active. The field is blank at normal session termination.

**OWNER**

The IMS ID (RSEname if an XRF system) of the IMS system that currently owns this resource. If the resource is not currently owned, this field will be displayed as NONE

**SRM**

The scope of recovery for a resource, and from where the end-user significant status is maintained and recovered.

**CONV**

Frequently changes for a resource, and thus there are performance considerations related to maintaining end-user significant status. The installation can tell IMS how to recover end-user significant status by specifying the level of recovery for each status. Shown for each resource is the level of recovery for each end-user significant status.

**STSN**

Frequently changes for a resource, and thus there are performance considerations related to maintaining end-user significant status. The installation can tell IMS how to recover end-user significant status by specifying the level of recovery for each status. Shown for each resource is the level of recovery for each end-user significant status.

**FPATH**

Frequently changes for a resource, and thus there are performance considerations related to maintaining end-user significant status. The installation can tell IMS how to recover end-user significant status by specifying the level of recovery for each status. Shown for each resource is the level of recovery for each end-user significant status.

**Examples**

The following are examples of the **/DISPLAY NODE** command.

**Example 1 for /DISPLAY NODE command**

Entry ET:

```
/DISPLAY NODE DTSLU* LUP1 ENDS01 LU6NDPA LU6NDPH
```

Response ET:

| NODE-USR             | TYPE | CID      | RECD | ENQCT | DEQCT | QCT | SENT | SYS3   |
|----------------------|------|----------|------|-------|-------|-----|------|--|
| DTSLU002             | SLUP | 010000D3 | 0    | 0     | 0     | 0   | 0    | SIGN(IMSUS05 )<br>IDLE CON                     |
| DTSLU202             | SLU2 | 010000CB | 0    | 0     | 0     | 0   | 1    | SIGN(IMSUS02 )<br>IDLE CON                     |
| DTSLU603<br>-IMSUS04 | LUT6 | 010000C7 | 0    | 0     | 0     | 0   | 0    | SIGN(IMSUS04 )<br>IDLE CON PRI                 |
| DTSLU205             | SLU2 | 010000A5 | 2    | 1     | 1     | 0   | 3    | SIGN(IMSUS14 )<br>IDLE CONV-ACT CON            |
| DTSLU204             | SLU2 | 010000A4 | 3    | 0     | 0     | 0   | 4    | SIGN(IMSUS13 )<br>IDLE CON EXC                 |
| DTSLU203             | SLU2 | 010000A3 | 3    | 0     | 0     | 0   | 4    | SIGN(IMSUS12 )<br>PRST(WTOR )<br>IDLE MFST CON |
| LUP1                 | SLUP | 010000CD | 0    | 0     | 0     | 0   | 0    | IDLE CON STATIC                                |
| ENDS01               | SLU2 | 010000A6 | 1    | 0     | 0     | 0   | 2    | SIGN(IMSUS08 )<br>IDLE CON STATIC              |
| LU6NDPA              | LUT6 |          |      |       |       |     |      |  |

```

-LU6SPG      010000BB      0      0      0      0      0 IDLE CON PRI
-CA12       010000BD      0      0      0      0      0 IDLE CON PRI
-CA11       010000BF      0      0      0      0      0 IDLE CON PRI
LU6NDPH  LUT6
-CA14       010000C1      0      0      0      0      0 IDLE CON PRI
-N/A        00000000      0      0      0      0      0 IDLE STATIC
-N/A        00000000      0      0      0      0      0 IDLE STATIC
*90240/134730*

```

Explanation: User IMSUS05 is signed on to dynamic node DTSLU002. User IMSUS02 is signed on to dynamic node DTSLU202. User IMSUS04 is allocated to ISC node DTSLU603. User IMSUS14 is signed on to dynamic node DTSLU205 and has an active conversation. User IMSUS13 is signed on to dynamic node DTSLU204 and is in exclusive mode. User IMSUS12 is signed on to dynamic node DTSLU203 and has a preset destination of LTERM WTOR and is in MFS test mode. Static node LUP1 is logged on. User IMSUS08 is signed on to static node ENDS01. Users LU6SPG, CA12, and CA11 are allocated to static ISC node LU6NDPA, which means node LU6NDPA has 3 active parallel sessions. User CA14 is allocated to static ISC node LU6NDPH, which means node LU6NDPH has one active parallel session.

**Example 2 for /DISPLAY NODE command**

Entry ET:

```
/DISPLAY NODE NSLUTP1 NSLUTP6 NPLUTP6
```

Response ET:

```

NODE-USR TYPE      CID      RECD ENQCT DEQCT  QCT  SENT
NSLUTP1  SLU1      00000000      0      0      0      0      0 IDLE
NSLUTP6  LUT6      00000000      5      3      2      1      5 IDLE
NPLUTP6  LUT6
-A        00000000      1      1      1      0      1 IDLE FORCE
-B        00000000     10     25     13     12     9 IDLE
-N/A      00000000      0      0      0      0      0 IDLE
-C        00000000      0      4      4      0      4 IDLE
*90229/083059*

```

Entry ET:

```
/DISPLAY NODE ALL
```

Response ET:

```

NODE-USR TYPE      CID      RECD ENQCT DEQCT  QCT  SENT  SYS3
WRIGHT   SLU2      00000000      0      0      0      0      0 IDLE
LUNS01   NTO       00000000      0      0      0      0      0 IDLE
WS12     FIN       00000000      0      0      0      0      0 IDLE
VR3275A1 3277     00000000      0      0      0      0      0 IDLE
VR3286A1 3286     00000000      0      0      0      0      0 IDLE
LUP1     SLUP      00000000      0      0      0      0      0 IDLE
Q3290A   SLU2      00000000      0      0      0      0      0 IDLE
LU6FP02  LUT6      00000000      0      0      0      0      0 IDLE
LU6NDPA  LUT6
-N/A     00000000      0      0      0      0      0 IDLE
-N/A     00000000      0      0      0      0      0 IDLE
-N/A     00000000      0      0      0      0      0 IDLE
NDNTOXA1 NTO       00000000      0      0      0      0      0 ASR
ND3287A1 SLU1      00000000      0      0      0      0      0 ASR
ND3287A2 SLU1      00000000      0      0      0      0      0 IDLE
ND3287A3 SLU1      00000000      0      0      0      0      0 IDLE
ND3287A4 SLU1      00000000      0      0      0      0      0 ASR
NDSLUA21 SLU2      00000000      0      0      0      0      0 ASR
NDSLUA22 SLU2      00000000      1      1      0      1      1 ASR
NDSLUPA1 SLUP      00000000      0      0      0      0      0 ASR
NDSLUPA2 SLUP      00000000      0      0      0      0      0 IDLE
NDLU6XSG LUT6      00000000      0      0      0      0      0 IDLE
NDLU6XPG LUT6
-N/A     00000000      0      0      0      0      0 ASR
-N/A     00000000      0      0      0      0      0 ASR
-N/A     00000000      0      0      0      0      0 ASR
-N/A     00000000      0      0      0      0      0 ASR
*91213/100107*  SYS3

```

Entry ET:



```
/DISPLAY NODE IN902D1 IN902D4
```

Response ET:

| NODE-USR       | TYPE | CID      | RECD | ENQCT | QCT | SENT    |
|----------------|------|----------|------|-------|-----|---------|
| IN902D1        | SLU1 | 100121C5 | 125  | 125   | 0   | 125 CON |
| *91012/192544* |      |          |      |       |     |         |

Entry ET:

```
/DISPLAY NODE NLUTP6P USER C
```

Response ET:

| NODE-USR       | TYPE | CID      | RECD | ENQCT | DEQCT | QCT | SENT |
|----------------|------|----------|------|-------|-------|-----|------|
| NLUTP6P        | LUT6 |          |      |       |       |     |      |
| -C             |      | 00000000 | 0    | 10    | 8     | 2   | 8    |
| *90229/083059* |      |          |      |       |       |     |      |

### **Example 3 for /DISPLAY NODE command**

The following commands illustrate the use of **/DISPLAY** to monitor changes in the mode table values for a node.

Entry ET:

```
/DISPLAY NODE LUTYPEP1 MODE
```

Response ET:

| NODE-USR       | TYPE | DEF MODETBL | ACT MODETBL |
|----------------|------|-------------|-------------|
| LUTYPEP1       | SLUP | DEFRESP     |             |
| *90179/100206* |      |             |             |

Explanation: DEFRESP is the mode table name defined for node LUTYPEP1 at system definition. The session is not active so the ACT MODETBL field is blank.

Entry ET:

```
/OPN NODE LUTYPEP1
```

Response ET:

```
DFS058I OPNDST COMMAND COMPLETED
```

Entry ET:

```
/DISPLAY NODE LUTYPEP1 MODE.
```

Response ET:

| NODE-USR       | TYPE | DEF MODETBL | ACT MODETBL |
|----------------|------|-------------|-------------|
| LUTYPEP1       | SLUP | DEFRESP     | DEFRESP     |
| *90179/100508* |      |             |             |

Explanation: A mode table name was not specified with the **/OPNDST** command so the default value defined at system definition was used to initiate the session.

Entry ET:

```
/CLS NODE LUTYPEP1
```

Response ET:

```
DFS058I CLSDST COMMAND COMPLETED
```

Entry ET:

```
/DISPLAY NODE LUTYPEP1 MODE
```

Response ET:

```
NODE-USR TYPE   DEF MODETBL  ACT MODETBL
LUTYPEP1 SLUP   DEFRESP
*90179/100630*
```

Explanation: Active mode table name displays as blank at normal session termination.

Entry ET:

```
/OPN NODE LUTYPEP1 MODE ALPHA.
```

Response ET:

```
DFS058I OPNDST COMMAND COMPLETED
```

Entry ET:

```
/DISPLAY NODE LUTYPE1 MODE
```

Response ET:

```
NODE-USR TYPE   DEF MODETBL  ACT MODETBL
LUTYPEP1 SLUP   DEFRESP      ALPHA
*90179/100805*
```

Explanation: The mode table name specified with the **/OPNDST** command (ALPHA) is used to initiate the session. The default value specified at system definition (DEFRESP) is overridden by the **/OPNDST** command.

#### **Example 4 for /DISPLAY NODE command**

The following example shows the display of all nodes with the automatic session restart designation.

Entry ET:

```
/DISPLAY NODE AUTOSR
```

Response ET:

```
NODE-USR TYPE   CID      RECD ENQCT DEQCT  QCT  SENT
WS12     FIN     00000000  0    0    0    0    0 ASR
NODE0005 FIN     00000000  0    0    0    0    0 ASR
NODE0006 FIN     00000000  0    0    0    0    0 ASR
NODE0007 FIN     00000000  0    0    0    0    0 ASR
NTOLUNS  NTO     00000000  0    0    0    0    0 ASR IDLE
NT02741  NTO     00000000  0    0    0    0    0 ASR IDLE
LU6NODE2 LUT6
-N/A     00000000  0    0    0    0    0 ASR IDLE
-N/A     00000000  0    0    0    0    0 ASR IDLE
-N/A     00000000  0    0    0    0    0 ASR IDLE
*90179/101609*
```

#### **Example 5 for /DISPLAY NODE command**

Entry ET:

```
/DISPLAY NODE NODE1 NODE2 QCNT
```

Response ET:

```
NODE      GBLQCT
NODE1     100000
NODE2     25
*95200/170817*
```

Entry ET:

```
/DISPLAY NODE NODE1 USER USER1 USER2 QCNT
```

Response ET:

```
NODE/USER      GBLQCT
NODE1
-USER1          10
-USER2          0
*95200/170817*
```

**Example 6 for /DISPLAY NODE command**

Entry ET:

```
/DISPLAY NODE FPEN0001 EMHQ QCNT
```

Response ET:

```
LTERM          GBLQCT
FPEN0001        0
*98203/143542*
```

**Example 7 for /DISPLAY NODE command**

Entry ET:

```
/DISPLAY NODE DTSLU* DTSLU202 L3270A RECOVERY
```

Response ET:

```
NODE-USR OWNER SRM   CONV STSN FPATH
DTSLU002 IMSA  GLOBAL Y    Y    Y
DTSLU603
-IMSUS04 IMSA  LOCAL  Y    Y    Y
DTSLU202 IMSB  GLOBAL  Y    N    N
L3270A   IMSA  LOCAL  Y    N    Y
*99240/134730*
```

**Example 8 for /DISPLAY NODE command: ISC TCP/IP nodes**

In the following example, the value TCP in the TYPE column of the command response indicates that the node CIC4 is an ISC TCP/IP node. The string of asterisks in the CID column indicates that a VTAM connection identifier (CID) is not applicable to the ISC TCP/IP terminal. Two parallel sessions (users) are shown on the node: CIC4U07 and CIC4U08.

Entry ET:

```
/DISPLAY NODE CIC4
```

Response ET:

```
NODE-USR TYPE  CID          RECD ENQCT DEQCT  QCT  SENT
CIC4    TCP
-CIC4U07 *****      0      0      0      0      0 SIGN(CIC4U07)
        IDLE CON
-CIC4U08 *****      0      0      0      0      0 SIGN(CIC4U08)
        IDLE CON
```

**Related reference**

[“Status and attributes for the /DISPLAY command” on page 501](#)

A list of the attributes and status shown in the **/DISPLAY** command are described in the following table.  
[QUERY NODE command \(Commands\)](#)

## **/DISPLAY OASN SUBSYS command**

Use the **/DISPLAY OASN SUBSYS** command to display the outstanding recovery units (Origin Application Schedule Numbers) associated with the external subsystem (not CCTL subsystem) specified by the SUBSYS keyword. ESS TYPE is now displayed on the output of the **/DIS OASN SUBSYS** command.

The OASN is assigned by IMS when it schedules an application into a dependent region. The OASN, coupled with the IMS ID, becomes the recovery token for units of work distributed to other subsystems.

Subsections:

- [“Environment” on page 616](#)
- [“Syntax” on page 616](#)
- [“Examples” on page 616](#)

### **Environment**

The following table lists the environments (DB/DC, DBCTL, and DCCTL) in which you can use the command and keywords.

*Table 295. Valid environments for the /DISPLAY OASN SUBSYS command and keywords*

| <b>Command / Keywords</b> | <b>DB/DC</b> | <b>DBCTL</b> | <b>DCCTL</b> |
|---------------------------|--------------|--------------|--------------|
| <b>/DISPLAY</b>           | X            | X            | X            |
| OASN                      | X            | X            | X            |
| SUBSYS                    | X            | X            | X            |

### **Syntax**

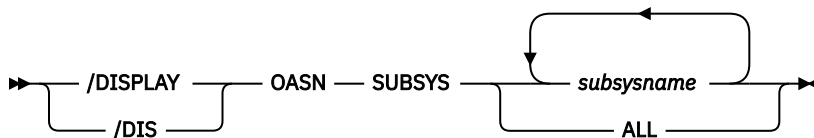

### **Examples**

Entry ET:

```
/DISPLAY OASN SUBSYS ALL
```

Response ET:

```

SUBSYS  OASN  ESSTYPE
V10A    0000000003  DB2
        0000000004
V10B    0000000005  DB2
*13242/145734*
  
```

TSO SPOC input:

```
DIS OASN SUBSYS ALL
```

TSO SPOC output:

```
Log for . . . : DIS OASN SUBSYS ALL

IMSpIex . . . . . : PLEX1
Routing . . . . . : SYS3
Start time . . . . : 2013.256 16:01:46.39
Stop time . . . . . : 2013.256 16:01:46.48
Return code . . . . : 00000000
Reason code . . . . : 00000000
Reason text . . . . :
Command master . . : SYS3

MbrName  Messages
-----
SYS3     SUBSYS  OASN     ESSTYPE
SYS3     V10A
SYS3           0000000003
SYS3           0000000004
SYS3     V10B
SYS3           0000000005
SYS3     *13256/160146*
```

## /DISPLAY OLDS command

Use the **/DISPLAY OLDS** command to display the system logging status.

The ddnames for the online log data sets that are currently online are listed in the sequence used. That is, the one currently being used is listed first, with the one most recently used listed next, and so on. OLDS status information is displayed with each ddname. The meanings of these status messages is provided. In the case of dual logging, two lines of status output are displayed per OLDS ID; the first for the primary OLDS and the second for the secondary OLDS.

Subsections:

- [“Environment” on page 617](#)
- [“Syntax” on page 617](#)
- [“Keywords” on page 618](#)
- [“Usage notes” on page 618](#)
- [“Output fields” on page 619](#)
- [“Examples” on page 619](#)

### Environment

The **/DISPLAY OLDS** command is valid in DB/DC, DBCTL, and DCCTL environments.

### Syntax

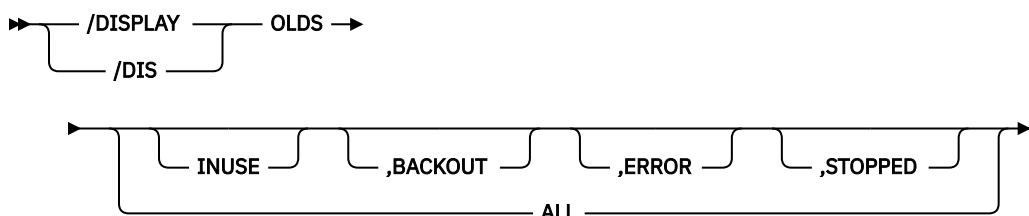

## Keywords

The following keywords can be specified for the **/DISPLAY OLDS** command. These keywords specify selection criteria used to select which OLDS are to be included in the display output. All these keywords are optional. If none are specified, ALL is the default action. When multiple keywords are specified, an OLDS that satisfies any one of the specified criteria is included in the output.

### ALL

Displays status of each online OLDS.

### INUSE

Displays current output OLDS.

### BACKOUT

Displays OLDS that contains dynamic backout data for currently active PSTs.

### ERROR

Displays OLDS that have encountered error conditions.

### STOPPED

Displays stopped OLDS.

## Usage notes

**/DISPLAY OLDS** shows the percentage of the OLDS used (shown under % FULL in the output) and the rate at which it is being filled (shown under RATE in the output). The RATE is the average number of blocks written to the current OLDS since the last **/DISPLAY OLDS** was issued. If no blocks were written, the RATE is 0, or, if elapsed time is 0, the previous RATE will be displayed.

When the archive status of an OLDS is scheduled or started and DBRC has generated the JCL for the archive job, the archive job name will be included in the output.

Following the detailed OLDS data set information, the dual OLDS state (DUAL, DEGRADED DUAL, NONDEGRADABLE DUAL or SINGLE) and the WADS recording state (DUAL, SINGLE, or NO) are displayed. Also, the DDNAMEs of all available WADS are displayed. The DDNAMEs of the current WADS are preceded by an asterisk (\*).

The SLDSREAD status is also displayed. If SLDSREAD ON is displayed, IMS is enabled to retrieve both SLDS and OLDS data. If SLDSREAD OFF is displayed, IMS is not enabled to retrieve SLDS data.

If the backout of one or more active dependent regions would require the SLDS (all of the region's log records are not available from the OLDS), the following text is displayed in front of the SLDSREAD ON or SLDSREAD OFF character string: SLDS REQUIRED FOR BACKOUT - RGN *nnnnn*, where *nnnnn* is the region number of the dependent region that owns the oldest record required for backout.

If there are one or more active dependent regions that could potentially require backout, but the SLDS is not required, the following text is displayed: OLDS REQUIRED FOR BACKOUT - RGN *nnnnn*, where *nnnnn* is the region number of the dependent region that owns the oldest record required for backout.

An OLDS that is stopped or had an I/O error is dynamically deallocated after it is no longer needed for backout.

The **/DISPLAY OLDS** command also shows the following fields:

### BSN

Represents a block of data that is written to the OLDS.

### LSN

Represents an individual log record. An underscore is printed to separate the two halves of the 8-byte LSN for readability even though the LSN does not contain an underscore.

You can use the LSN and BSN values to determine whether they are approaching their finite limits. The limit for the BSN is X'FFFFFFFF' and the limit for the LSN is X'FFFFFFFF\_FFFFFFFF'.

**Restriction:** Under the dual logging environment, the number of primary OLDS and secondary OLDS must be the same; otherwise, the status of the OLDS is incorrect.

The **/DISPLAY OLDS** command also shows whether zHyperWrite is enabled when data is written to the OLDS or WADS. If zHyperWrite is enabled for the OLDS, OLDS=YES is displayed. If zHyperWrite is not enabled for the OLDS, then OLDS=NO is displayed. Likewise, if zHyperWrite is enabled for the WADS, WADS=YES is displayed. If zHyperWrite is not enabled for the WADS, then WADS=NO is displayed.

## Output fields

The **/DISPLAY OLDS** command shows one of the following as the archive status of each OLDS:

### NEEDED

This OLDS needs to be archived. It cannot be reused for output logging until it has been archived.

### SCHEDULED

An archive job has been generated for this OLDS.

### STARTED

A job to archive this OLDS has started execution.

### AVAILABLE

Either this OLDS is empty or it has been archived. It can be reused for output logging.

The **/DISPLAY OLDS** command also shows the following status information for OLDS:

### IN USE

This is the current output log OLDS. The display line for this OLDS also has an asterisk (\*) in the left margin.

### STOPPED

**/STOP** command entered for this OLDS or the OLDS is being internally stopped because of write errors.

### WRT-ERR

A write I/O error occurred on this OLDS data set.

### CLSE

An error occurred when closing this data set. The Log Recovery utility can be used to correct this condition.

### PREV CLSER

The previous OLDS could not be closed because of an I/O error and this OLDS is required by the Log Recovery utility to correct the condition.

### NOT USABLE

This data set is not being used for logging. When operating in "Degraded Dual" state, the other data set in this OLDS pair was used for output but this data set was not used because of a previous data set error.

### BACKOUT

This OLDS is potentially required for backout.

### ZHYPERW

The ZHYPERWRITE OLDS=YES request is honored for the current OLDS during the OPEN processing.

## Examples

Entry ET:

```
/DISPLAY OLDS
```

Response ET:

```
OLDS-DDNAME % FULL RATE ARCH-JOB   ARCH-STATUS  OTHER-  
STATUS
```

```

*DFSOLP00      60      6                               IN USE
DFSOLP03                               AVAILABLE
DFSOLP02                               AVAILABLE
DFSOLP01                               AVAILABLE
SINGLE OLDS LOGGING, SINGLE WADS LOGGING
AUTOMATIC ARCHIVE = 01
WADS = *DFSWADS0 DFSWADS1
SLDSREAD ON
CURRENT BSN = 00000025, LSN = 00000000_000001ED
ZHYPERWRITE: OLDS = NO, WADS = YES
*17263/091638*

```

If the ZHYPERWRITE request is honored, the ZHYPERW keyword is displayed for the current OLDS:

| DFS000I<br>SYS3 | OLDS-DDNAME                                     | % FULL | RATE | ARCH-JOB | ARCH-STATUS | OTHER-STATUS    |
|-----------------|---|--------|------|----------|-------------|-----------------|
| DFS000I<br>SYS3 | *DFSOLP06                                       | 0      | 8    |          |             | IN USE, ZHYPERW |
| DFS000I<br>SYS3 | *DFSOLS06                                       | 0      | 8    |          |             | IN USE, ZHYPERW |
| DFS000I         | DFSOLP05  |        |      |          | AVAILABLE   | SYS3            |
| DFS000I         | DFSOLS05  |        |      |          | AVAILABLE   | SYS3            |
| DFS000I         | DFSOLP07  |        |      |          | AVAILABLE   | SYS3            |
| DFS000I         | DFSOLS07  |        |      |          | AVAILABLE   | SYS3            |
| DFS000I         | DUAL OLDS LOGGING, SINGLE WADS LOGGING          |        |      |          | SYS3        |                 |
| DFS000I         | AUTOMATIC ARCHIVE = 01                          |        |      |          | SYS3        |                 |
| DFS000I         | WADS = *DFSWADS2                                |        |      |          | SYS3        |                 |
| DFS000I         | SLDSREAD ON                                     |        |      |          | SYS3        |                 |
| DFS000I         | CURRENT BSN = 00000033, LSN = 00000000_000004EB |        |      |          |             | SYS3            |
| DFS000I         | ZHYPERWRITE: OLDS = YES, WADS = NO              |        |      |          | SYS3        |                 |
| DFS000I         | *21123/120510*                                  |        |      |          |             | SYS3            |

## /DISPLAY OTMA command

Use the **/DISPLAY OTMA** command to display the current status for IMS Open Transaction Manager Access (OTMA) clients and servers.

Subsections:

- [“Environment” on page 620](#)
- [“Syntax” on page 620](#)
- [“Usage notes” on page 620](#)
- [“Output fields” on page 621](#)
- [“Examples” on page 622](#)

### Environment

The **/DISPLAY OTMA** command is valid in DB/DC and DCCTL environments.

### Syntax

```

  >> /DISPLAY OTMA <<
    /DIS

```

### Usage notes

This command is functionally equivalent to the **/DISPLAY TMEMBER ALL** command.

If a super member is defined, information about the super member is also displayed. Because a super member does not interface with z/OS cross-system coupling facility (XCF), the XCF\_STATUS field is left blank. Because super members do not process input messages, OTMA security authorization is not performed. The SECURITY field is also left blank.



## Output fields

This command displays the following output fields:

### ACEEAGE

The accessor environment element (ACEE) aging value for the OTMA client. This value is used to perform the refresh for cached OTMA ACEEs for all user IDs.

If the **/SECURE OTMA ACEEAGE** command is issued to specify a global ACEE aging value, this field displays the aging value that is specified with the **/SECURE OTMA ACEEAGE** command for the OTMA server.

### ACEECT

The total number of cached OTMA ACEEs for the OTMA server.

### BETP

If **LITETP=YES** is specified in the DFSOTMA descriptor, this is the number of back-end tpipes for the member. Otherwise, it is zero.

### DRUEXIT

The name of any OTMA Destination Resolution exit routine that is associated with the tmember.

### GROUP/MEMBER

Each member in each XCF group. The server is always the first member that is displayed.

### INPT

The maximum number of input messages from this tmember that can be waiting at the same time to be processed. This value is primarily used for send-then-commit or CM1 messages.

### MAXTP

The maximum TPIPE limit that is specified in the OTMA client descriptor. If the MAXTP parameter is specified for DFSOTMA in the OTMA client descriptor, the MAXTP limit is displayed for the OTMA server. If there are one or more OTMA clients with the MAXTP limit defined and MAXTP is not specified for DFSOTMA, the highest limit defined among the members is displayed for the OTMA server.

### SECURITY

The security status for each member or server. The security status can be one of the following:

- NONE
- JOIN
- CHECK
- FULL
- PROFILE

### SMEM

The name of the super member.

### TIB

For an OTMA target member (tmember), the current number of input messages from this tmember that IMS is processing. For an OTMA server, the total number of input messages from all tmembers that IMS is processing plus the reserved message blocks for message processing. This value is primarily used for send-then-commit or CM1 messages.

For the OTMA internal member DFSYICAL, this field shows the number of IMS regions that are waiting for responses to synchronous program switch requests.

### T/O

The timeout value for OTMA to wait for an ACK or NACK for an OTMA output message.

### TOA

Indicates whether the TOACEE= parameter on the DFSOTMA client descriptor is YES to enable ACEE flood control or NO to disable ACEE flood control. This status is valid only for the OTMA server.

### TPCNT

The tpipe count for the OTMA client or for the IMS server.

For an OTMA client, this field indicates the current tpipe count for that member. For the IMS server, this field indicates the current global tpipe count for the IMS server. This count value is limited to display at most 99999. When 99999 is displayed, it indicates the tpipe count is 99999 or higher.

### USER-STATUS

The user status for each member. The status can be one of the following:

- ACCEPT TRAFFIC
- DISCONNECTED
- FLOOD
- IN SLOWDOWN
- MAX TPIPE
- SERVER
- SERVER+FLOOD
- SMQ BACKEND
- SYNC P2P
- SYNC P2P+FLOOD
- WAIT BID
- WAIT RESPONSE

### WGF

The tpipe weighting factor for calculating the adjusted total tpipe count for detecting flood condition. A value of 0 indicates that the OTMA lightweight tpipe function is disabled.

### XCF-STATUS

The XCF status for each member. The status can be one of the following:

- ACTIVE
- CREATED
- FAILED
- NOT DEFINED
- QUIESCED
- STO-INPUT
- UNKNOWN

### Examples

The following are examples of the **/DISPLAY OTMA** command.

#### **Example 1 for /DISPLAY OTMA command**

Entry ET:

```
/DISPLAY OTMA
```

Response ET:

| GROUP/MEMBER | XCF-STATUS | USER-STATUS    | SECURITY | TIB    | INPT  | SMEM  |        |      |    |
|--------------|------------|----------------|----------|--------|-------|-------|--------|------|----|
|              | DRUEXIT    | T/O            | TPCNT    | ACEEAG | MAXTP | TA    | ACEECT | BETP |    |
| WGF          |            |                |          |        |       |       |        |      |    |
| HARRY        |            |                |          |        |       |       |        |      |    |
| -IMS1        | ACTIVE     | SERVER         | FULL     |        | 0     | 10000 |        |      |    |
| -IMS1        | N/A        | 0              | 0        | N/A    | 0     | N     | 0      | 0%   |    |
| -HWS001      | ACTIVE     | ACCEPT TRAFFIC | FULL     |        | 0     | 5000  | SM01   |      |    |
| -HWS001      | HWSYDRU0   | 5              | 0        |        | 0     | N     | N/A    | 0    | 0% |
| -SM01        |            | SUPER MEMBER   |          |        |       |       | SM01   |      |    |
| -SM01        | N/A        | 120            | 0        | 999999 | 0     | N     | N/A    | 0    |    |
|              |            |                |          |        |       |       |        | 0%   |    |

```

-MQS001    ACTIVE    ACCEPT TRAFFIC FULL    0 5000
-MQS001    MQSYDRU0 10      0      0      0 N N/A      0 0%

```

Explanation: The **/DISPLAY OTMA** command can be issued to display the status of IMS server and members. This command is functionally equivalent to the **/DIS TMEMBER ALL** command. The member information is displayed in random order. In the previous example, HARRY is the XCF group name for IMS and its OTMA clients. IMS1 is the server member running with OTMA activated. HWS001 and MQS001 are OTMA client members. The SM01 is an OTMA super member for asynchronous output messages. Each OTMA client has two-line status information.

**Example 2 for /DISPLAY OTMA Command**

Entry ET:

```
/DISPLAY OTMA
```

Response ET:

```

GROUP/MEMBER XCF-STATUS USER-STATUS SECURITY TIB INPT SMEM
DRUEXIT T/O TPCNT ACEEAG MAXTP TA ACEECT BETP WGF
HARRY
-IMS1 ACTIVE SERVER FULL 0 10000
-IMS1 N/A 0 0 N/A 0 N 0 0 0%
-HWS001 ACTIVE ACCEPT TRAFFIC FULL 0 5000 SM01
-HWS001 HWSYDRU1 5 0 0 0 N N/A 0 0%
-HWS002 ACTIVE ACCEPT TRAFFIC FULL 0 5000 SM01
-HWS002 HWSYDRU2 5 0 0 0 N N/A 0 0%
-SM01 SUPER MEMBER SM01
-SM01 N/A 120 0 999999 0 N N/A 0
0%
-HWS003 ACTIVE ACCEPT TRAFFIC FULL 0 5000 SM01
-HWS003 HWSYDRU3 5 0 0 0 N N/A 0 0%

```

Explanation: The **/DISPLAY OTMA** command can be issued to display the status for OTMA clients and servers. This command is functionally equivalent to the **/DIS TMEMBER ALL** command. The member information is displayed in random order.

**Example 3 for /DISPLAY OTMA command**

Entry ET:

```
/DISPLAY OTMA
```

Response ET:

```

GROUP/MEMBER XCF-STATUS USER-STATUS SECURITY TIB INPT SMEM
DRUEXIT T/O TPCNT ACEEAG MAXTP TA ACEECT BETP
WGF
XCFGRP1
-IMS1 ACTIVE SERVER FULL 0 10000
-IMS1 N/A 0 0 N/A 0 N 0 0 0%
-HWS1 ACTIVE ACCEPT TRAFFIC FULL 0 5000
-HWS1 HWSYDRU0 239 0 3600 0 N N/A 0 0%
-HWS2 ACTIVE ACCEPT TRAFFIC FULL 0 5000
-HWS2 HWSYDRU0 239 0 7200 0 N N/A 0
0%
-HWS3 ACTIVE ACCEPT TRAFFIC FULL 0 5000
-HWS3 HWSYDRU0 239 0 0 0 N N/A 0
0%
*09121/172200* IMS1

```

Explanation: The **/DISPLAY OTMA** command can be issued to display the ACEE aging value for the OTMA client or member. OTMA uses this value to determine if a cached ACEE for a user ID needs to be refreshed. In this example, the aging value for HWS1 is 3600 seconds, and the aging value for HWS2 is 7200 seconds. Any cached ACEE that only HWS1 uses has an aging value of 3600 seconds, and any cached ACEE that only HWS2 uses has an aging value of 7200 seconds. If a cached ACEE is used by both HWS1 and HWS2, the aging value is 3600 seconds, which is the lowest value between 3600 and 7200 seconds. Because no aging value is specified for HWS3, IMS always creates a non-cached ACEE for users from HWS3.

#### Example 4 for /DISPLAY OTMA command

Entry ET:

```
/DISPLAY OTMA
```

Response ET:

| GROUP/MEMBER | XCF-STATUS | USER-STATUS    | SECURITY | TIB    | INPT  | SMEM |        |      |
|--------------|------------|----------------|----------|--------|-------|------|--------|------|
|              | DRUEXIT    | T/O            | TPCNT    | ACEEAG | MAXTP | TA   | ACEECT | BETP |
| WGF          |            |                |          |        |       |      |        |      |
| IMSXCFGP     |            |                |          |        |       |      |        |      |
| -IMS1        | ACTIVE     | SERVER         | FULL     | 30     | 8000  |      |        |      |
| -IMS1        | N/A        | 0              | 0 N/A    | 0      | N     | 0    | 0      | 0%   |
| -HWS001      | ACTIVE     | ACCEPT TRAFFIC | FULL     | 20     | 5000  |      |        |      |
| -HWS001      | HWSYDRU0   | 5              | 1        | 0      | N     | N/A  | 0      | 0%   |
| -DFSYICAL    |            | SYNC P2P       | FULL     | 10     | 5000  |      |        |      |
| -DFSYICAL    | N/A        | 5              | 1        | 0      | N     | N/A  | 0      | 0%   |

In this example, IMSXCFGP is the XCF group name for IMS and its OTMA clients. The server member name for OTMA is IMS1. HWS001 and DFSYICAL are the names of the OTMA client members. The DFSYICAL member is an internal OTMA client that processes synchronous program switch requests initiated by DL/I ICAL calls from application programs. The DFSYICAL member has the USER-STATUS of SYNC P2P. The TIB field for the DFSYICAL member shows that there are 10 IMS regions waiting for responses to DL/I ICAL synchronous program switch requests. The HWS001 member is a standard OTMA client member, connected via XCF, that has 20 active messages. The total TIB for this IMS system is 30. None of the members are using an OTMA Destination Resolution exit routine.

#### Example 5 for /DISPLAY OTMA command

Entry ET:

```
/DISPLAY OTMA
```

Response ET:

| GROUP/MEMBER   | XCF-STATUS | USER-STATUS    | SECURITY | TIB    | INPT  | SMEM |        |      |     |
|----------------|------------|----------------|----------|--------|-------|------|--------|------|-----|
|                | DRUEXIT    | T/O            | TPCNT    | ACEEAG | MAXTP | TA   | ACEECT | BETP | WGF |
| XCFGRP1        |            |                |          |        |       |      |        |      |     |
| -IMS1          | ACTIVE     | SERVER+FLOOD   | FULL     | 11000  | 10000 |      |        |      |     |
| -IMS1          | N/A        | 0              | 0 N/A    | 0      | N     | 0    | 0      | 0%   |     |
| -HWS1          | ACTIVE     | ACCEPT TRAFFIC | FULL     | 3000   | 5000  |      |        |      |     |
| -HWS1          | HWSYDRU0   | 120            | 11       | 0      | N     | N/A  | 0      | 0%   |     |
| -HWS2          | ACTIVE     | ACCEPT TRAFFIC | FULL     | 4000   | 5000  |      |        |      |     |
| -HWS2          | HWSYDRU0   | 120            | 22       | 0      | N     | N/A  | 0      |      |     |
|                |            |                |          |        |       |      |        | 0%   |     |
| -HWS3          | ACTIVE     | ACCEPT TRAFFIC | FULL     | 4000   | 5000  |      |        |      |     |
| -HWS3          | HWSYDRU0   | 120            | 33       | 0      | N     | N/A  | 0      |      |     |
|                |            |                |          |        |       |      |        | 0%   |     |
| *09121/172200* |            | IMS1           |          |        |       |      |        |      |     |

The /DISPLAY OTMA command can be issued to display the active OTMA messages (TIB) in the system and in each OTMA client. The flood limit (INPT) for the entire system and each OTMA client can also be displayed. In this example, because the global flood limit of the system is set to 10000, the total active OTMA messages (3000 + 3000 + 4000) is 11000, which is over the global limit. The USER-STATUS shows SERVER+FLOOD to indicate that the global flood limit was specified in client descriptor or in the **/START TMBER ALL INPUT** command, and IMS has reached this OTMA global flood limit. The applications that use OTMA clients HWS1, HWS2, and HWS3 must reroute the OTMA transaction to a different IMS. All the new input transactions from all the OTMA clients are rejected with OTMA sense code x'0030' and reason code x'0002'.

#### Example 6 for /DISPLAY OTMA command

Entry ET:

```
/DISPLAY OTMA
```

Response ET:

| GROUP/MEMBER | XCF-STATUS | USER-STATUS | SECURITY | TIB    | INPT   | SMEM  |        |       |
|--------------|------------|-------------|----------|--------|--------|-------|--------|-------|
|              | DRUEXIT    | T/O         | TPCNT    | ACEEAG | MAXTP  | TA    | ACEECT | BETP  |
| WGF          |            |             |          |        |        |       |        |       |
| HARRY        |            |             |          |        |        |       |        |       |
| -IMS1        | ACTIVE     | SERVER      | FULL     |        | 0      | 10000 |        |       |
| -IMS1        | N/A        | 0           | 0        | N/A    | 123456 | N     | 0      | 0 28% |
| -HWS001      | ACTIVE     | ACCEPT      | TRAFFIC  | FULL   |        | 0     | 5000   |       |
| -HWS001      | HWSYDRU0   | 5           | 0        | 0      | 500    | N     | N/A    | 0 28% |

The **/DISPLAY OTMA** command can be issued to display the tpipe limits for the IMS system and each OTMA member. In this example, the global MAXTP limit is set to 123456. The OTMA member HWS001 has a small **MAXTP** limit which is set to 500. Since the tpipe weighting factor (WGF) shows a non-zero value of 28%, it indicates the OTMA LITETP function is activated.

### Related reference

[“/DISPLAY TMEMBER command” on page 685](#)

Use the **/DISPLAY TMEMBER** command to display the current target member status for IMS Open Transaction Manager Access (OTMA) clients and servers.

## **/DISPLAY OVERFLOWQ** command

Use the **/DISPLAY OVERFLOWQ** command to display a list of queue names that are in overflow mode for those coupling facility list structures specified (for the **STRUCTURE** keyword) that are in overflow mode.

It also displays the queue type of the resource for each queue.

Subsections:

- [“Environment” on page 625](#)
- [“Syntax” on page 625](#)
- [“Keywords” on page 626](#)
- [“Usage notes” on page 626](#)
- [“Output fields” on page 626](#)
- [“Examples” on page 627](#)

### Environment

The following table lists the environments (DB/DC, DBCTL, and DCCTL) in which you can use the command and keywords.

*Table 296. Valid environments for the /DISPLAY OVERFLOWQ command and keywords*

| Command / Keywords | DB/DC | DBCTL | DCCTL |
|--------------------|-------|-------|-------|
| <b>/DISPLAY</b>    | X     | X     | X     |
| OVERFLOWQ          | X     |       | X     |
| STRUCTURE          | X     |       | X     |

### Syntax



## Keywords

The following keywords can be specified for the **/DISPLAY OVERFLOWQ** command:

### STRUCTURE

Specifies the primary coupling facility list structures to be displayed.

## Usage notes

If a specified structure is not defined, the overflow structure name is displayed as NOT-DEFINED.

Queue names displayed might not be defined to the IMS subsystem on which this command is issued. If a queue type is not defined, the type is displayed as UNKNOWN, and the queue name is displayed as the 16-byte queue name (with the queue type as the first byte).

This command is valid only in a shared-queues environment.

If there are OTMA output messages that have been moved to the overflow structure, the **/DISPLAY OVERFLOWQ** command displays information about those messages. Instead of displaying the queue name that was used to queue the OTMA output messages, the character string 'TMSTMP-' is displayed. If the messages are queued to a regular member, the IMS ID of the IMS subsystem to which the messages have affinity is displayed following the 'TMSTMP-' string. If the messages are queued to a super member, the field following the 'TMSTMP-' string is left blank because output messages queued to a super member do not have affinity to any IMS subsystem. If the command is entered on a system where the TMEMBER and TPIPE are defined, the TMEMBER and TPIPE names are displayed. If the command is entered on a system where the TMEMBER and TPIPE are not defined, the character string 'UNKNOWN' is placed in the TMEMBER and TPIPE fields.

## Output fields

The following output fields are displayed by the **/DISPLAY OVERFLOWQ** command:

### APPC

The resource type on the overflow structure is an APPC outbound queue. The first eight bytes of the resource name displayed is the unique constant TMSTMP-. The next four bytes are the IMS ID of the IMS subsystem that has the LUNAME and TPNAME defined. If you issue the **/DISPLAY OVERFLOWQ** command on the system on which the LUNAME and TPNAME are defined, then the LUNAME and TPNAME also display.

When LUNAME and TPNAME cannot be located on the system on which they're defined, UNKNOWN appears under the LUNAME and TPNAME headings in the display output.

### BALGRP

The resource type on the overflow structure is a Fast Path PSB name. The resource name displayed is the Fast Path PSB name.

### LTERM

The resource type on the overflow structure is an LTERM. The resource name displayed is the LTERM name.

### OTMA

The resource type on the overflow structure is an OTMA outbound queue. The first eight bytes of the resource name displayed is the unique constant TMSTMP-. The next four bytes are the IMS ID of the IMS subsystem that has the TMEMBER and TPIPE defined. If you issue the **/DISPLAY OVERFLOWQ** command on the system on which the TMEMBER and TPIPE are defined, then the TMEMBER and TPIPE are also displayed.

When LUNAME and TPNAME cannot be located on the system on which they're defined, UNKNOWN appears under the LUNAME and TPNAME headings in the display output.

## REMOTE

The resource type on the overflow structure is a remote LTERM, remote transaction, or an MSNAME. The resource name displayed is the remote LTERM name, remote transaction name, or the msname.

## SUSPENDTRAN

The resource type on the overflow queue is a suspended transaction and the messages are on the suspend queue. The resource name displayed is the transaction name. If the transaction that is suspended is a serial transaction, or if local affinity has been set for a non-serial transaction, the first eight bytes displayed are the transaction name and the last seven bytes represent the IMS ID of the subsystem that enqueued the message.

## SERIALTRAN

The resource type on the overflow queue is a serial transaction. The first eight bytes of the resource name are the transaction name and the last seven bytes represent the IMS ID of the IMS subsystem that inserted the message for the transaction.

## TRANSACTION

The resource type on the overflow queue is a transaction. The resource name displayed is the transaction name. If local affinity has been set for the transaction, the first eight bytes displayed are the transaction name and the last seven bytes represent the IMS ID of the IMS subsystem that enqueued the message.

## UNKNOWN

The resource type of the resource on the overflow queue is not known to this IMS subsystem. The 16 byte resource name is displayed.

## Examples

The following are examples of the **/DISPLAY OVERFLOWQ** command:

### Example 1 for /DISPLAY OVERFLOWQ command

Entry ET:

```
/DISPLAY OVERFLOWQ STRUCTURE ALL
```

Response ET:

| STRUC-RSCTYPE  | OFLSTRUC-RSCNAME                  | LUNAME-TMEMBER   | TPNAME-TPIPE   |
|----------------|-----------------------------------|------------------|--|
| IMSMGQ01       | IMSMGQ01OFLW                      |                  |  |
| TRANSACTION    | TRANA                             |                  |  |
| LTERM          | LTERMX                            |                  |  |
| SUSPENDTRAN    | TRANA                             |                  |  |
| APPC           | TMSTMP- IMSA                      | LUNAME1          | TPNAME1  |
| SERIALTRAN     | TRANABC IMSA                      |                  |  |
| APPC           | TMSTMP- IMSA                      |                  |  |
| OTMA           | TMSTMP- IMSA                      | TMEMBERA         | TPIPEA   |
| APPC           | TMSTMP- IMSA                      | NETWORK2.LUNAME2 | TPNM123456789012+<br>3456789012345678+<br>901234567890 |
| OTMA           | TMSTMP- IMSB                      |                  |  |
| REMOTE         | TRANB                             |                  |  |
| REMOTE         | LTERMA                            |                  |  |
| UNKNOWN        | ASIXTEENCHARNAME                  |                  |  |
| REMOTE         | MSNAMEA                           |                  |  |
| IMSEMHQ01      | OVERFLOW STRUCTURE IS NOT DEFINED |                  |  |
| BALGRP         | FPPSB1                            |                  |  |
| LTERM          | LTERMY                            |                  |  |
| BALGRP         | FPPSB2                            |                  |  |
| *95200/170817* |                                   |                  |  |

### Example 2 for /DISPLAY OVERFLOWQ command

Entry ET:

```
/DIS OVERFLOWQ STRUCTURE ALL
```

Response ET:

```

STRUC-RSCTYPE OFLSTRUC-RSCNAME LUNAME-TMEMBER TPNAME-TPIPE
IMSMGQ01      IS NOT IN OVERFLOW MODE
IMSEMHQ01     IMSEMHQ01OFLW
BALGRP        DDLTRN14
*04302/165656*

```

### Example 3 for /DISPLAY OVERFLOWQ command

Entry ET:

```
/DIS OVERFLOWQ STRUCTURE IMSEMHQ01
```

Response ET:

```

STRUC-RSCTYPE OFLSTRUC-RSCNAME LUNAME-TMEMBER TPNAME-TPIPE
IMSEMHQ01     IMSEMHQ01OFLW
BALGRP        DDLTRN14
*04302/165834*

```

### Example 4 for /DISPLAY OVERFLOWQ command

Entry ET:

```
/DISPLAY OVERFLOWQ STRUCTURE AL
```

Response ET:

```

STRUC-RSCTYPE OFLSTRUC-RSCNAME LUNAME-TMEMBER TPNAME-TPIPE
IMSMGQ01      IMSMSGQ01OFLW
OTMA          TMSTMP-          SM01          TPIPE1
OTMA          TMSTMP-          UNKNOWN        UNKNOWN
OTMA          TMSTMP- SYS3     HWS003        TPIPE1
IMSEMHQ01     IS NOT IN OVERFLOW MODE

```

Explanation: This example shows that messages queued to TPIPE1 of super member SM01 have been moved to the overflow structure. Messages queued to TPIPE1 of regular member HWS003 have also been moved to the overflow structure. Messages for a TMEMBER or TPIPE that is unknown to the IMS that processed the command have also been moved to the overflow structure.

## /DISPLAY PGM command

Use the **/DISPLAY PGM** command to display the status of programs.

Subsections:

- [“Environment” on page 628](#)
- [“Syntax” on page 628](#)
- [“Usage notes” on page 629](#)
- [“Equivalent IMS type-2 commands” on page 629](#)
- [“Output fields” on page 629](#)
- [“Examples” on page 629](#)

### Environment

The **/DISPLAY PGM** command is valid in DB/DC, DBCTL, and DCCTL environments.

### Syntax



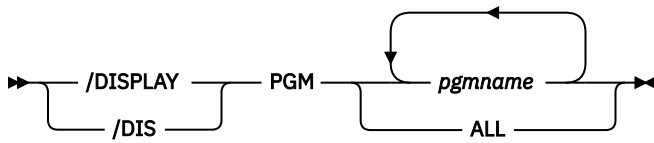

## Usage notes

For DBCTL, this command displays the status of BMP programs, DEDB utilities, and CCTL PSBs. Because DBCTL has no knowledge of CICS programs, their status is not displayed.

## Equivalent IMS type-2 commands

The following table shows variations of the **/DISPLAY PGM** command and the IMS type-2 commands that perform similar functions.

Table 297. Type-2 equivalents for the /DISPLAY PGM command

| Task                                  | /DISPLAY PGM command        | Similar IMS type-2 command                     |
|---------------------------------------|-----------------------------|--|
| Displays information about a program. | /DISPLAY PGM <i>pgmname</i> | QRY PGM NAME( <i>pgmname</i> )<br>SHOW(ALL)    |
|                                       |                             | QUERY PGM NAME( <i>pgmname</i> )<br>SHOW(TRAN) |

## Output fields

The status displayed can be one of the following:

```
DB-STOPD
I/O PREVEN
LOCK
NOTINIT
STOPPED
TRA
```

## Examples

Entry ET:

```
/DISPLAY PGM APOL1 DBFSAMP3 BMP255
```

Response ET:

```
PROGRAM      TRAN      TYPE
APOL1        APOL11   TP
              APOL12
              APOL13
              APOL14
              APOL15
              APOL16
              APOL17
              APOL18
DBFSAMP3     FPSAMP1   FPM
BMP255      TRAN255   BMP
              TXCD255
              TXCD255W
*90288/140450*  SYS3
```

Entry ET:

```
/DISPLAY PGM ALL
```

Response ET:

```
PROGRAM   TRAN      TYPE
AD2TP     TSTAD2A  TP    NOTINIT
          TSTAD2R1
APOL1     APOL11   TP    NOTINIT
          APOL12
A3270     A3270    TP    NOTINIT
          3270S
BMAAJK41  BHE4     TP    NOTINIT
          NQE4
          SHE4
BMP255    TRAN255  BMP   NOTINIT
BTAEJK01                BMP   NOTINIT
BTAPJK01                BMP   NOTINIT
BTAPJK11                BMP   NOTINIT
BTAPJK21                BMP   NOTINIT
BTGGJK01                BMP   NOTINIT
BTGGJK11                BMP   NOTINIT
BTGOJK01                BMP   NOTINIT
BTGRJK05                BMP   NOTINIT
CPGM1V0   CONV11V0 TP    NOTINIT
          CONV12V0
          CONV13V0
```

```
DBF#FPU0                FPU
DBFSAMP3  FPSAMP1  FPM
DBFSAMP4  FPSAMP2  TP    NOTINIT
DBFSAM22  TP1      FPM
DBFSAM99  TP2      TP    NOTINIT
DCLECH05  DCL      TP    NOTINIT
DDLTP04   TXCDBP04 FPM
DDLTP05   TXCDBP05 FPM
DDLTP06   TXCDBP06 FPM
DDLTP07   TXCDBP07 FPM   NOTINIT
DDLTP08   TXCDBP08 FPM   NOTINIT
DDLTP09   TXCDBP09 FPM   NOTINIT
V2MPPA02  V2MRP01  TP    NOTINIT
          V2MRP02
V2MPPC01  V2SNS01  TP
          V2SRS02
V2MPPC02  V2MRS04  TP    NOTINIT
V2MPPP01  V2SNS02  TP    NOTINIT
          V2SRS03
          V2SRS04
V2MPPPP02 V2MRP03  TP    NOTINIT
          V2SRP01
WTCPLI    TESTPLI  TP    NOTINIT
*89184/142553*
```

### Related reference

[“Status and attributes for the /DISPLAY command” on page 501](#)

A list of the attributes and status shown in the **/DISPLAY** command are described in the following table.

[QUERY PGM command \(Commands\)](#)

## **/DISPLAY POOL** command

Use the **/DISPLAY POOL** command to display processor storage utilization statistics for the various IMS storage pools.

Subsections:

- [“Environment” on page 631](#)
- [“Syntax” on page 631](#)
- [“Usage notes” on page 632](#)
- [“Equivalent IMS type-2 commands” on page 634](#)
- [“Abbreviations used in the /DISPLAY POOL command” on page 634](#)

- “Examples” on page 640

## Environment

The **/DISPLAY POOL** command is valid in DB/DC, DBCTL, and DCCTL environments.

## Syntax

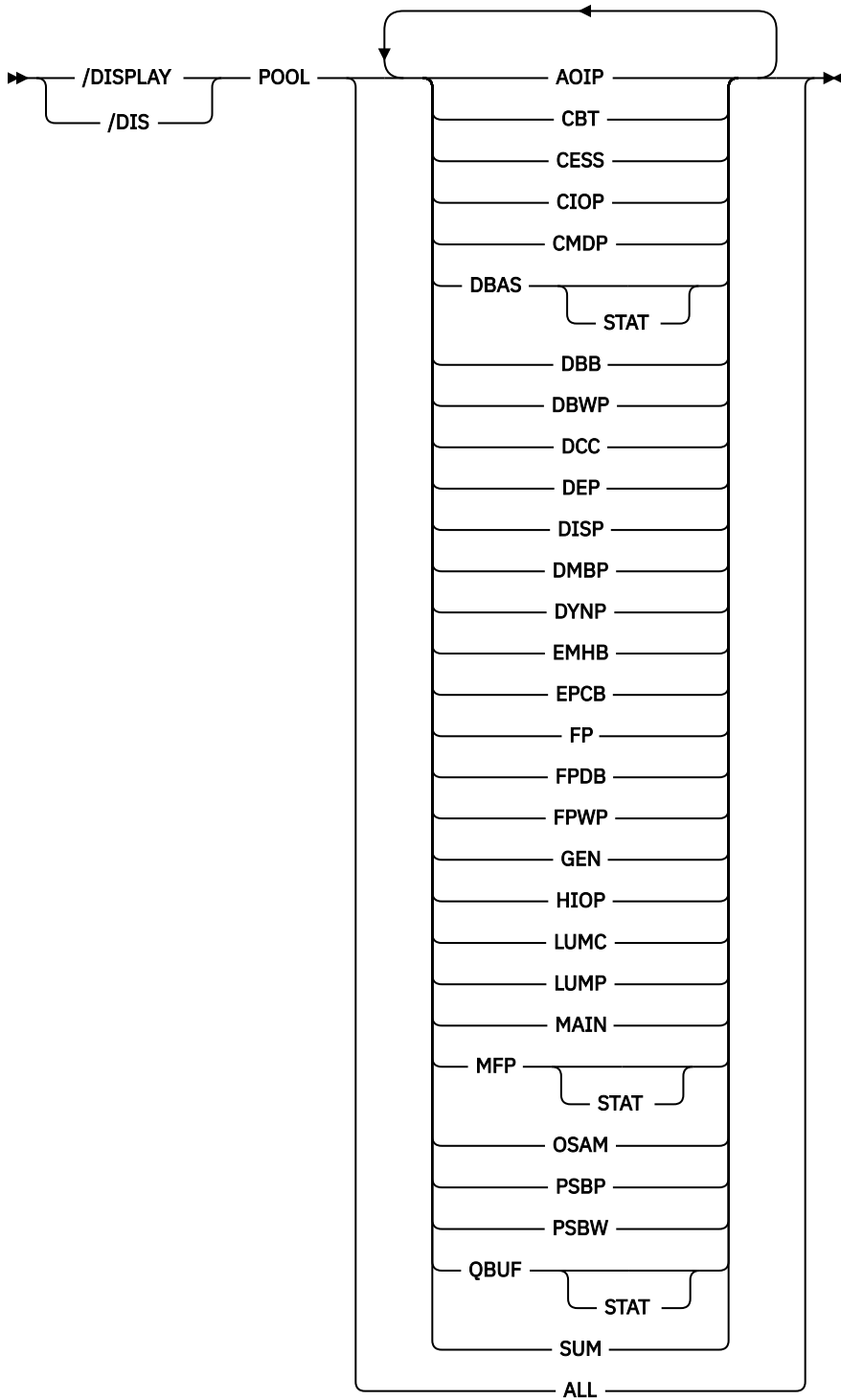

## Usage notes

When the **/DISPLAY POOL** command is issued from a specific environment (such as DBCTL), only the information that is valid for that environment is displayed.

Certain storage utilization statistics can be obtained with the DL/I STAT call.

Control block table (CBT) pools are defined in DFSCBT00 and are grouped into classes for the purposes of the **/DISPLAY POOL** command. All CBT pools are valid in all environments.

For a list of all of the IMS CBT pools with a brief description of each, see [IMS Control Block Table \(CBT\) Pools \(Diagnosis\)](#).

The classes and corresponding parameters are:

### **CBT**

This displays storage for all CBT pools. Use of this operand generates a large amount of display output.

### **DBB**

This displays database-related storage.

### **DCC**

This displays storage associated with DC.

### **DEP**

This displays storage associated with the dependent region structure.

### **DISP**

This displays dispatcher-related storage.

### **FP**

This displays Fast Path-related storage.

### **GEN**

This displays storage that has no particular functional association.

### **OSAM**

This displays OSAM-related storage.

### **SUM**

This displays summary statistics for each of the above storage classes.

A CBT class display shows information for each pool in that class. The amount of storage displayed for these pools might change, because the storage is obtained as needed and can be freed when not in use. In addition, a summary of the total current global and local storage in the class and in all CBT pools is displayed.

If SUM is specified, a summary of the total current local and global storage for each CBT class is displayed.

For the following storage pools, the amount of storage obtained is specified during system definition or by way of EXEC statement overrides in the IMS procedure JCL.

### **DBAS**

Database buffer pools (includes VSAM buffer pools if VSAM is in the system, and also includes buffer space used by sequential buffering).

Statistics for VSAM local shared resource pools are displayed in the order in which the pools are defined. For each local shared resource pool, the statistics of each subpool are displayed in ascending order by buffer size. The smallest buffers are displayed first and the largest buffers are displayed last. If an index subpool exists in the shared resource pool, its statistics follow the data subpool statistics. Index statistics are also displayed in ascending order by buffer size.

Headings for VSAM subpools include the pool ID of the local shared resource pool. They also indicate whether the subpool is a data subpool (type D) or an index subpool (type I).

The output from issuing the **/DIS POOL DBAS** command is equivalent to the output from issuing the type-2 **QUERY POOL TYPE(DBAS) SHOW(STATISTICS)** command.

**DBWP**

Database working pool.

**DMBP**

Data management block pool.

**EPCB**

Fast Path PCB extension pool for MPPs.

**FPDB**

Fast Path database buffer pool.

**MAIN**

Working storage pool.

**MFP**

Message format block pool.

**PSBP**

Program specification block pool.

**PSBW**

Program specification block work area.

**QBUF**

Message queue buffer pool. Parameter QBUF can also be used to indicate how close the system is to automatic shutdown because of message queue buildup. The statistics displayed for each data set are:

- The maximum number of records available before initiation of automatic shutdown. This value is defined by the SHUTDWN parameter of the MSGQUEUE macro. This value is not the total number of records available in the data set.
- The number of records currently in use.
- The percentage of records currently in use to records available before initiation of automatic shutdown. When the value described in this item reaches 100%, an internal checkpoint DUMPQ will automatically be initiated. The number of records in the queue data set might continue to increase during the checkpoint DUMPQ, resulting in percentages greater than 100 being displayed.
- In a shared-queues environment, two additional lines of output are displayed: the current buffer in-use count and the buffer in-use high water mark.

The following table shows the environments (DB/DC, DBCTL, or DCCTL) in which each storage pool is valid. If a pool is not valid in an environment, it will not appear when **/DISPLAY POOL ALL** is issued.

*Table 298. Storage pools and their environments*

| <b>Storage pools</b> | <b>DB/DC</b> | <b>DBCTL</b> | <b>DCCTL</b> |
|----------------------|--------------|--------------|--------------|
| AOIP                 | X            | X            | X            |
| CESS                 | X            | X            | X            |
| CIOP                 | X            | X            | X            |
| CMDP                 | X            | X            | X            |
| DBAS                 | X            | X            |              |
| DBWP                 | X            | X            |              |
| DMBP                 | X            | X            |              |
| DYNP                 | X            |              | X            |
| EMHB                 | X            | X            | X            |

Table 298. Storage pools and their environments (continued)

| Storage pools | DB/DC | DBCTL | DCCTL |
|---------------|-------|-------|-------|
| EPCB          | X     | X     | X     |
| FPDB          | X     | X     |       |
| FPWP          | X     | X     |       |
| HIOP          | X     |       | X     |
| LUMC          | X     |       | X     |
| LUMP          | X     |       | X     |
| MAIN          | X     | X     | X     |
| MFP           | X     |       | X     |
| PSBP          | X     | X     | X     |
| PSBW          | X     | X     | X     |
| QBUF          | X     |       | X     |

### Equivalent IMS type-2 commands

The following table shows variations of the **/DISPLAY POOL** command and the IMS type-2 commands that perform similar functions.

Table 299. Type-2 equivalents for the **/DISPLAY POOL** command

| Task   | <b>/DISPLAY POOL</b> command | Similar <b>IMS type-2</b> command         |
|--|------------------------------|---|
| Displays processor storage utilization statistics for OSAM and VSAM database buffer pools. | <b>/DISPLAY POOL DBAS</b>    | QUERY POOL TYPE(DBAS)<br>SHOW(STATISTICS) |

### Abbreviations used in the **/DISPLAY POOL** command

The following lists indicate the abbreviations used in the **/DISPLAY POOL** command for each pool and subpool.

#### **CBT pool display**

##### **NAME**

Storage pool name

##### **SP**

Associated MVS user number

##### **CURR**

The current bytes allocated to the pool

##### **MAX**

Maximum size in bytes that the pool ever reached

##### **GETS**

Number of GETMAINS issued

##### **FREES**

Number of FREEMAINS issued

### ***Message queue pool***

#### **BFRS**

Number of processor storage queue buffers. In a shared queues environment, the number of buffers can be dynamically expanded from the number originally defined. This field displays the number of buffers currently available.

#### **SIZE**

Usable size of one queue buffer, excluding the buffer prefix

#### **ENQ**

Number of message enqueues

#### **DEQ**

Number of message dequeues

#### **CAN**

Number of canceled messages

#### **WAIT**

Number of I/O waits issued

#### **I/O**

Number of I/O operations. In a shared-queues environment, it is the sum of CQSPUTs and CQSREADs.

#### **ERR**

Number of I/O errors

### ***Message format pool***

#### **SIZE**

Pool size

#### **SPACE**

Maximum amount of free space

#### **DIRS**

Space used by MFS Dynamic Directory

#### **REQ1**

Number of block requests from pool

#### **I/O**

Number of fetch I/O operations

#### **DIR**

Number of directory I/O operations

#### **WAIT**

Number of immediate fetch I/O operations

#### **FREE**

Amount of free space currently in the pool

#### **ERR**

Number of I/O errors

### ***Database buffer pools***

The database buffer pool display consists of the OSAM buffer pool and, if VSAM is in the system, the VSAM buffer subpool. The display also includes information about the buffer space used by sequential buffering within the online IMS subsystem. The information about the sequential buffering buffer space includes:

#### **MAX**

Maximum amount of space available for sequential buffering

#### **FREE**

Amount of currently free space for sequential buffering

#### **CUR**

The current bytes allocated to the pools for sequential buffering

**HIGH**

Highest amount of space ever used in this run for sequential buffering

***OSAM buffer subpool*****This topic contains Product-sensitive Programming Interface information.**

Statistics for each OSAM subpool are displayed separately. The final display provides the statistical summation for all the OSAM subpools in all the shared resource pools.

**SIZE**

Buffer pool size

**REQ1**

Number of block requests

**REQ2**

Number of requests satisfied in the pool plus new blocks created

**READ**

Number of read requests issued

**BISAM**

Number of BISAM reads issued plus QISAM SETLs

**WRITES**

Number of OSAM writes issued

**KEYC**

Number of retrieve by key calls number

**LCYL**

Number of OSAM format logical cylinder requests

**PURG**

Number of synchronization calls received

**OWNRR**

Number of release ownership requests

**ERRORS**

Number of permanent errors now in the pool and largest number of permanent errors during this run

***VSAM buffer subpool*****This topic contains Product-sensitive Programming Interface information.**

Statistics for each VSAM subpool are displayed separately. The final display provides the statistical summation for all the VSAM subpools in all the shared resource pools.

**BSIZE**

The size of the buffers in this VSAM subpool

**POOLID**

Local shared resource pool ID

**TYPE**

The subpool type: I (Index) or D (Data)

**RRBA**

Number of retrieval requests by RBA

**RKEY**

Number of retrieval requests by key

**BFALT**

Number of logical records altered

**NREC**

Number of new VSAM logical records created

**SYNPTS**

Number of system checkpoint requests



**NMBUFS**

Number of buffers in this VSAM subpool

**VRDS**

Number of VSAM control interval reads (OVFLO indicates that the total overflowed a 4-byte field; that is, the total exceeded 4,294,967,295)

**FOUND**

Number of control intervals VSAM found in the subpool through lookaside (OVFLO indicates that the total overflowed a 4-byte field; that is, the total exceeded 4,294,967,295)

**VWTS**

Number of VSAM control interval writes

**ERRORS**

Total number of permanent errors now in the pool and total number of permanent errors in this run

The BSIZE value in the final display is ALL.

***Enhanced OSAM buffer subpool*****This topic contains Product-sensitive Programming Interface information.**

Each OSAM subpool is displayed separately. The final display provides the statistical summation for all the OSAM subpools.

**ID**

The 4-character POOLID provided at subpool definition time

**BSIZE**

The size of the buffers in this OSAM subpool

**NBUF**

Number of buffers for this subpool

**FX=**

The fix options for this subpool. Y/N indicates whether the DATA BUFFER PREFIX/DATA BUFFERS are fixed.

**LCTREQ**

Number of LOCATE-type calls for this subpool

**ALTREQ**

Number of buffer alter calls for this subpool. This count includes NEW BLOCK and BYTALT calls.

**PURGRQ**

Number of PURGE calls for this subpool

**FNDIPL**

Number of LOCATE-type calls, for this subpool, where data is already in the OSAM pool

**BFSRCH**

Number of buffers searched by all LOCATE-type calls for this subpool

**RDREQ**

Number of READ I/O requests for this subpool

**BFSTLW**

Number of single block writes initiated by buffer steal routine for this subpool

**PURGWR**

Number of buffers written by purge

**WBSYID**

Number of LOCATE calls, for this subpool, that waited because of busy ID

**WBSYWR**

Number of LOCATE-type calls, for this subpool, that waited because of busy writing

**WBSYRD**

Number of LOCATE-type calls, for this subpool, that waited due to busy buffer reading

**WRLSEO**

Number of buffer steal or purge requests, for this subpool, that waited for ownership to be released.

**WNOBFR**

Number of buffer steal requests, for this subpool, that waited because no buffers were available to be stolen

**ERRORS**

Total number of I/O errors for this subpool, or the number of the buffers locked in the pool because of write errors for this subpool

**CFREAD**

Number of blocks read from CF.

**CFEXPC**

Number of blocks expected but not read.

**CFWRPR**

Number of blocks written to CF (prime).

**CFWRCH**

Number of blocks written to CF (changed).

**STGCLF**

Number of blocks not written (STG CLS full).

**XVIINV**

Number of XI buffer-invalidate calls.

**XICLCT**

Number of buffers found invalidated by XI on VECTOR call.

**SBSEQR**

Number of immediate (SYNC) sequential reads (SB stat).

**SBANTR**

Number of anticipatory reads (SB stat).

For the summary totals, the POOLID is not shown. BSIZE is set to ALL. NBUF indicates the total number of buffers in the pool. The FX= field is replaced by OSM=, which shows the total size of the OSAM buffer pool.

***Enhanced VSAM buffer subpool*****This topic contains Product-sensitive Programming Interface information.**

Each VSAM subpool is displayed separately. The final display provides the statistical summation for all the VSAM subpools.

**ID**

The 4-character POOLID provided at subpool definition time

**BSIZE**

The size of the buffers in this VSAM subpool

**TYPE**

identifies the subpool as containing INDEX or DATA buffer

**FX=**

Number of options for this subpool. Y/N is used to indicate whether the INDEX BUFFERS/DATA BUFFER PREFIX/ DATA BUFFERS are fixed.

**RRBA**

Number of retrieval requests by RBA

**RKEY**

Number of retrieval requests by KEY

**BFALT**

Number of logical records altered

**NREC**

Number of new VSAM logical records created

**SYNC PT**

Number of system checkpoint (synchronization point) requests

**NBUFS**

Number of buffers in this VSAM subpool

**VRDS**

Number of VSAM control interval reads (OVERFLOW indicates that the total overflowed a 4-byte field; that is, the total exceeded 4,294,967,295)

**FOUND**

Number of control intervals VSAM found in the subpool through lookaside (OVERFLOW indicates that the total overflowed a 4-byte field; that is, the total exceeded 4,294,967,295)

**VWTS**

Number of VSAM control interval writes

**HSR-S**

Number of successful VSAM reads from Hiperspace buffers

**HSW-S**

Number of successful VSAM writes to Hiperspace buffers

**HS NBUFS**

Number of Hiperspace buffers defined for this subpool

**HS R/W-FAIL**

Number of failed VSAM reads/writes from or to Hiperspace buffers. This indicates the number of times a VSAM READ/WRITE request from or to Hiperspace resulted in DASD I/O.

**ERRORS**

Number of permanent write errors now in the subpool, or the largest number of errors in this execution

The BSIZE value in the final display is the total size of all the VSAM subpool buffers. BSIZE is set to ALL. For the summary totals, the POOLID is not shown. The TYPE and FX= fields are replaced by VS=, which is the total size of the VSAM subpool in virtual storage, and HS=, which is the total size of the VSAM subpool in Hiperspace.

***Fast Path database buffer pool*****AVAIL**

Number of available page-fixed database buffers

**WRITING**

Number of page-fixed database buffers being written to disk, including the buffers being filled with sequential dependent segments

**PGMUSE**

Number of page-fixed buffers allocated to PSTs

**UNFIXED**

Number of available buffers for starting a new region

**POOLNAME**

Name of the private buffer pool for the area. This name is specified in the VSPEC member.

**CISIZE**

Control interval size of the private pool for the area.

**PBUF**

Size allocated for the primary pool (specified in the VSPEC member).

**SBUF**

Size allocated for the secondary pool (specified in the VSPEC member).

**MAX**

Maximum number of buffers for the private pool (specified in the VSPEC member).

**CURRENT**

Total number of buffers currently in the pool, including both primary and secondary allocations.

**LK**

Y indicates that buffer lookaside is active for the pool; N indicates that it is not.

**HITS**

Percentage of searches of the pool for which a buffer was found. Only displayed for lookaside pools.

**VALID**

Percentage of times a buffer found in the pool had valid data. An Invalid buffer is read from DASD and the pool copy is replaced. Only displayed for lookaside pools.

You use the percentages displayed for HITS and VALID together.

**Example:** If HITS is 40%, and VALID is 75%, a buffer was found in the pool 40% of the time, and of that 40%, 75% of the buffers found had valid data, that is, 30% of the HITS had valid data. So, IMS had to read data from DASD approximately 70% of the time.

***PSBP, DMBP, PSBW, DBWP, EPCB, and MAIN buffer pools*****SIZE**

pool size

**FREE**

amount of currently free space

**HIGH**

Highest amount of space ever used in this run

***AOIP, CESS, CIOP, CMDP, DYNP, EMHB, FPWP, HIOP, LUMC, and LUMP buffer pools***

During the execution of IMS, the AOIP, CESS, CIOP, CMDP, DYNP, EMHB, FPWP, HIOP, LUMC, and LUMP buffer pools can dynamically expand and contract.

Internally, each dynamic pool has one or more blocks of storage that are not contiguous, each divided into fixed-length buffers. By obtaining new blocks and releasing unused blocks, a buffer pool can expand or contract during the execution of IMS. The number of blocks needed for each pool depends on several factors such as the number of buffer requests from the pool, buffer size, and block size.

**SIZE**

Pool size

**HIGH**

Maximum size since last checkpoint

**LIMIT**

Upper expansion limit

**OVERFLOW**

Size of the oversized chain

**Examples**

The following are examples of the **/DISPLAY POOL** command.

For a list of all of the IMS CBT pools with a brief description of each, see [IMS Control Block Table \(CBT\) Pools \(Diagnosis\)](#).

***Example 1 for /DISPLAY POOL command***

Entry ET:

/DISPLAY POOL ALL

Response ET:

| NAME | SP# | CURR | MAX  | GETS | FREES |
|------|-----|------|------|------|-------|
| IOSB | 228 | 28K  | 28K  | 3    | 0     |
| GIOB | 228 | 0K   | 0K   | 0    | 0     |
| OSWA | 228 | 8K   | 8K   | 1    | 0     |
| GOWA | 228 | 0K   | 0K   | 0    | 0     |
| PST  | 231 | 52K  | 56K  | 14   | 1     |
| DPST | 231 | 40K  | 44K  | 11   | 1     |
| SAP  | 231 | 132K | 132K | 32   | 0     |
| GQMW | 231 | 16K  | 16K  | 4    | 0     |
| LQMW | 0   | 324K | 324K | 81   | 0     |
| D1WA | 228 | 8K   | 8K   | 2    | 0     |
| DL2W | 0   | 8K   | 8K   | 2    | 0     |
| DG2W | 231 | 4K   | 4K   | 1    | 0     |
| QSAV | 231 | 4K   | 16K  | 3    | 2     |
| VRPL | 231 | 16K  | 16K  | 4    | 0     |
| LSAV | 0   | 808K | 808K | 201  | 1     |
| AWE  | 231 | 112K | 112K | 28   | 0     |
| PDIR | 231 | 36K  | 36K  | 1    | 0     |
| DDIR | 231 | 28K  | 28K  | 1    | 0     |
| LCRE | 241 | 4K   | 4K   | 1    | 0     |
| PCIB | 0   | 0K   | 0K   | 0    | 0     |
| SIDX | 241 | 4K   | 4K   | 1    | 0     |
| RRE  | 241 | 4K   | 4K   | 1    | 0     |
| SMB  | 231 | 62K  | 62K  | 1    | 0     |
| BCPT | 231 | 4K   | 4K   | 1    | 0     |
| GESE | 241 | 0K   | 0K   | 0    | 0     |
| EPST | 231 | 208K | 208K | 20   | 0     |
| IDT  | 241 | 0K   | 0K   | 0    | 0     |
| DBRC | 231 | 0K   | 0K   | 0    | 0     |
| TTAB | 231 | 224K | 224K | 56   | 0     |
| EZS  | 241 | 0K   | 0K   | 0    | 0     |
| FNCB | 231 | 0K   | 0K   | 0    | 0     |
| TCBT | 231 | 4K   | 4K   | 1    | 0     |
| CMWU | 231 | 12K  | 12K  | 3    | 0     |
| FSRB | 228 | 4K   | 4K   | 1    | 0     |
| KLSD | 0   | 0K   | 0K   | 0    | 0     |
| IRLM | 231 | 0K   | 0K   | 0    | 0     |
| STTR | 231 | 52K  | 52K  | 13   | 0     |
| BQEL | 231 | 0K   | 0K   | 0    | 0     |
| USMU | 229 | 0K   | 0K   | 0    | 0     |
| RCTE | 231 | 3K   | 3K   | 1    | 0     |
| SLOG | 231 | 4K   | 4K   | 1    | 0     |
| ADSC | 228 | 0K   | 0K   | 0    | 0     |
| FPCP | 231 | 0K   | 0K   | 0    | 0     |
| AESL | 231 | 0K   | 0K   | 0    | 0     |
| XPST | 231 | 16K  | 16K  | 4    | 0     |
| BXQE | 231 | 16K  | 16K  | 4    | 0     |
| SRBC | 228 | 8K   | 8K   | 2    | 0     |
| MSGP | 241 | 4K   | 4K   | 1    | 0     |
| LPST | 251 | 8K   | 8K   | 2    | 0     |
| CULE | 231 | 4K   | 4K   | 1    | 0     |
| RPST | 241 | 4K   | 4K   | 1    | 0     |
| VTCB | 251 | 18K  | 18K  | 0    | 0     |
| RECA | 0   | 19K  | 19K  | 1    | 0     |
| GSAV | 231 | 0K   | 0K   | 0    | 0     |
| FEIB | 231 | 0K   | 0K   | 0    | 0     |
| IEQE | 0   | 0K   | 0K   | 0    | 0     |
| L56X | 231 | 4K   | 4K   | 1    | 0     |
| X124 | 241 | 4K   | 4K   | 1    | 0     |
| STAT | 241 | 4K   | 4K   | 1    | 0     |
| EQEL | 241 | 0K   | 0K   | 0    | 0     |
| TT24 | 231 | 24K  | 24K  | 6    | 0     |
| LGWA | 231 | 104K | 104K | 26   | 0     |
| VWA  | 231 | 8K   | 8K   | 2    | 0     |
| LGWX | 0   | 0K   | 0K   | 0    | 0     |
| LQB  | 251 | 104K | 104K | 0    | 0     |
| RCNT | 251 | 2K   | 2K   | 0    | 0     |
| DDRE | 0   | 0K   | 0K   | 0    | 0     |
| CCB  | 0   | 0K   | 0K   | 0    | 0     |
| LGND | 251 | 8K   | 8K   | 2    | 0     |
| USRD | 251 | 4K   | 4K   | 1    | 0     |
| LS24 | 0   | 2K   | 2K   | 1    | 0     |
| GS24 | 231 | 0K   | 0K   | 0    | 0     |
| CLLE | 231 | 64K  | 64K  | 16   | 1     |
| QMBA | 0   | 8K   | 8K   | 1    | 0     |

```

AHDR 251      0K      0K      0      0
XMCI 241     180K     180K     45     1
DBPB 231      0K      0K      0      0
LG24  0       12K     12K      3      0
IAFP 231      0K      0K      0      0
RACW 231      0K      0K      0      0
LUB  251      0K      0K      0      0
TIB  251     28K     28K      1      0
DESC 251      0K      0K      0      0
PF62 251      0K      0K      0      0
QAB  251      0K      0K      0      0
LCLL  0       436K    436K    109     0
CBLK 251      0K      0K      0      0
SVPG 231     24K     24K      6      0
SVPL  0       148K    148K     37     0
SOPB  0        0K      0K      0      0
CBT POOLS      GLBL    1541K  LCL    2236K
MESSAGE QUEUE POOL:  BFRS/SIZE 20/2112
ENQ   6 DEQ   6 CAN   30 WAIT   0 I/O   15 ERR   0
QBLKS: MAX # RECORDS AVAIL 1332 CUR IN USE 3 = 0 %
SMSGQ: MAX # RECORDS AVAIL 5940 CUR IN USE 4 = 0 %
LMSGQ: MAX # RECORDS AVAIL 1350 CUR IN USE 4 = 0 %
MESSAGE FORMAT POOL: SIZE 49152 SPACE 48576 DIRS 9011
REQ1  2 I/O  2 DIR  4
WAIT  2 FREE 48432 ERR  0
SEQUENTIAL BUFFERING: STATUS = NOT INIT
MAX   N.A. FREE  N.A. CURR  0K HIGH  0K
OSAM DB BUFFER POOL: ID 004K BSIZE 4K NBUF 1000 FX=Y/Y
LCTREQ 1765296 NEWBLK 0 ALTREQ 340800
PURGRQ 39371 FNDIPL 1370897 BFSRCH 1987604
RDREQ 378355 BFSTLW 0 PURGWR 150284
WBSYID 1431 WBSYWR 0 WBSYRD 0
WRLSEO 296 WNOBFR 0 ERRORS 00000/00000
OSAM DB BUFFER POOL: ID 008K BSIZE 8K NBUF 100 FX=Y/Y
LCTREQ 228080 NEWBLK 0 ALTREQ 0
PURGRQ 0 FNDIPL 204190 BFSRCH 316566
RDREQ 23891 BFSTLW 0 PURGWR 0
WBSYID 0 WBSYWR 0 WBSYRD 0
WRLSEO 0 WNOBFR 0 ERRORS 00000/00000
OSAM DB BUFFER POOL: ID 012K BSIZE 12K NBUF 100 FX=Y/Y
LCTREQ 83282 NEWBLK 0 ALTREQ 6896
PURGRQ 4384 FNDIPL 70743 BFSRCH 81395
RDREQ 7622 BFSTLW 0 PURGWR 6118
WBSYID 0 WBSYWR 0 WBSYRD 0
WRLSEO 0 WNOBFR 0 ERRORS 00000/00000
OSAM DB BUFFER POOL: BSIZE ALL NBUF 1200 OSM= 6000K
LCTREQ 2076667 NEWBLK 0 ALTREQ 347697
PURGRQ 43755 FNDIPL 1645837 BFSRCH 2385576
RDREQ 409869 BFSTLW 0 PURGWR 156402
WBSYID 1431 WBSYWR 0 WBSYRD 0
WRLSEO 296 WNOBFR 0 ERRORS 00000/00000
VSAM DB BUFFER POOL: ID VLP1 BSIZE 2K TYPE D FX=N/Y/N
RRBA 0 RKEY 0 BFALT 0
NREC 0 SYNC PT 29446 NBUFS 500
VRDS 1253 FOUND 0 VWTS 68
HSR-S 0 HSW-S 0 HS NBUFS 0
HS R/W-FAIL 000000/000000 ERRORS 000000/000000
VSAM DB BUFFER POOL: ID VLP1 BSIZE 4K TYPE D FX=N/Y/N
RRBA 370 RKEY 187583 BFALT 0
NREC 10750 SYNC PT 29446 NBUFS 1000
VRDS 145632 FOUND 0 VWTS 9771
HSR-S 0 HSW-S 50 HS NBUFS 50
HS R/W-FAIL 000000/000000 ERRORS 000000/000000
VSAM DB BUFFER POOL: ID VPL1 BSIZE 8K TYPE D FX=N/Y/N
RRBA 7375 RKEY 6704 BFALT 0
NREC 0 SYNC PT 29446 NBUFS 100
VRDS 7362 FOUND 0 VWTS 0
HSR-S 0 HSW-S 0 HS NBUFS 0
HS R/W-FAIL 000000/000000 ERRORS 000000/000000
VSAM DB BUFFER POOL: BSIZE ALL VS= 5800K HS= 200K
RRBA 7745 RKEY 194287 BFALT 0
NREC 10752 SYNC PT 29446 NBUFS 1600
VRDS 154247 FOUND 0 VWTS 9839
HSR-S 0 HSW-S 50 HS NBUFS 50
HS R/W-FAIL 000000/000000 ERRORS 000000/000000
DMPB BUFFER POOL:
SIZE 200K FREE 200K HIGH 0K
PSBP BUFFER POOL:
SIZE 80K FREE 80K HIGH 0K
DPSB BUFFER POOL:
SIZE 160K FREE 160K HIGH 0K
CIOP BUFFER POOL:

```

```

SIZE      14K HIGH      65K LIMIT      NONE OVERFLOW      0K
MAIN BUFFER POOL:
SIZE      40K FREE      39K HIGH      1K
SPAP BUFFER POOL:
SIZE      0K HIGH      0K LIMIT      9999K OVERFLOW      0K
PSBW BUFFER POOL:
SIZE      600K FREE      600K HIGH      0K
DBWP BUFFER POOL:
SIZE      80K FREE      80K HIGH      0K
HIOP BUFFER POOL:
SIZE      214K HIGH      420K LIMIT      9999K OVERFLOW      0K
FPDB BUFFER POOL:
AVAIL =    60 WRITING =    0 PGMUSE =    0 UNFIXED =    90
POOLNAME CFSIZE PBUF SBUF  MAX CURRENT LK HITS VALID
1024 01024 00064 00016 00256 00064 N NA NA
2048 02048 00064 00016 00256 00064 N NA NA
CESS BUFFER POOL:
POOL IS NOT AVAILABLE FOR STATISTICS
EMHB BUFFER POOL:
SIZE      0K HIGH      0K LIMIT      NONE OVERFLOW      0K
FPWP BUFFER POOL:
SIZE      0K HIGH      0K LIMIT      NONE OVERFLOW      0K
EPCB BUFFER POOL:
SIZE      300K FREE      300K HIGH      0K
LUMP BUFFER POOL:
SIZE      68K HIGH      68K LIMIT      NONE OVERFLOW      0K
LUMC BUFFER POOL:
SIZE      0K HIGH      32K LIMIT      NONE OVERFLOW      0K
AOIP BUFFER POOL:
SIZE      82K HIGH      82K LIMIT      NONE OVERFLOW      0K
CMDP BUFFER POOL:
SIZE      0K HIGH      0K LIMIT      NONE OVERFLOW      0K
DYNP BUFFER POOL:
SIZE      42K HIGH      42K LIMIT      NONE OVERFLOW      0K
*92120/134306*

```

**Example 2 for /DISPLAY POOL command**

Entry ET:

```
/DISPLAY POOL AOIP
```

Response ET:

```

AOIP BUFFER POOL:
SIZE      32K HIGH      32K LIMIT      NONE OVERFLOW      0K
*92280/095545*

```

**Example 3 for /DISPLAY POOL command**

For a list of all of the IMS CBT pools with a brief description of each, see [IMS Control Block Table \(CBT\) Pools \(Diagnosis\)](#).

Entry ET:

```
/DISPLAY POOL CBT
```

Response ET:

| NAME | SP# | CURR | MAX | GETS | FREES |
|------|-----|------|-----|------|-------|
| IOSB | 228 | 20K  | 20K | 1    | 0     |
| GIOB | 228 | 0K   | 0K  | 0    | 0     |
| OSWA | 228 | 8K   | 8K  | 1    | 0     |
| GOWA | 228 | 0K   | 0K  | 0    | 0     |
| PST  | 231 | 52K  | 56K | 14   | 1     |
| DPST | 231 | 40K  | 44K | 11   | 1     |
| SAP  | 231 | 28K  | 28K | 6    | 0     |
| GQMW | 231 | 12K  | 12K | 3    | 0     |
| LQMW | 0   | 40K  | 40K | 10   | 0     |
| D1WA | 228 | 8K   | 8K  | 2    | 0     |
| DL2W | 0   | 8K   | 8K  | 2    | 0     |
| DG2W | 231 | 4K   | 4K  | 1    | 0     |
| QSAV | 231 | 4K   | 12K | 2    | 1     |
| VRPL | 231 | 16K  | 16K | 4    | 0     |
| LSAV | 0   | 68K  | 72K | 17   | 1     |
| AWE  | 231 | 12K  | 12K | 3    | 0     |

|           |     |      |       |     |      |
|-----------|-----|------|-------|-----|------|
| PDIR      | 231 | 36K  | 36K   | 1   | 0    |
| DDIR      | 231 | 28K  | 28K   | 1   | 0    |
| LCRE      | 241 | 4K   | 4K    | 1   | 0    |
| PCIB      | 0   | 0K   | 0K    | 0   | 0    |
| SIDX      | 241 | 4K   | 4K    | 1   | 0    |
| RRE       | 241 | 4K   | 4K    | 1   | 0    |
| SMB       | 231 | 61K  | 61K   | 1   | 0    |
| BCPT      | 231 | 4K   | 4K    | 1   | 0    |
| GESE      | 241 | 0K   | 0K    | 0   | 0    |
| EPST      | 231 | 144K | 144K  | 20  | 0    |
| IDT       | 241 | 0K   | 0K    | 0   | 0    |
| DBRC      | 231 | 0K   | 0K    | 0   | 0    |
| TTAB      | 231 | 184K | 184K  | 46  | 0    |
| EZS       | 241 | 0K   | 0K    | 0   | 0    |
| FNCB      | 231 | 0K   | 0K    | 0   | 0    |
| TCBT      | 231 | 4K   | 4K    | 1   | 0    |
| CMWU      | 231 | 8K   | 8K    | 2   | 0    |
| FSRB      | 228 | 4K   | 4K    | 1   | 0    |
| KLSD      | 0   | 0K   | 0K    | 0   | 0    |
| IRLM      | 231 | 0K   | 0K    | 0   | 0    |
| STTR      | 231 | 52K  | 52K   | 13  | 0    |
| BQEL      | 231 | 0K   | 0K    | 0   | 0    |
| USMU      | 229 | 0K   | 0K    | 0   | 0    |
| RCTE      | 231 | 3K   | 3K    | 1   | 0    |
| SLOG      | 231 | 4K   | 4K    | 1   | 0    |
| ADSC      | 228 | 0K   | 0K    | 0   | 0    |
| FPCP      | 231 | 0K   | 0K    | 0   | 0    |
| AESL      | 231 | 0K   | 0K    | 0   | 0    |
| XPST      | 231 | 16K  | 16K   | 4   | 0    |
| BXQE      | 231 | 16K  | 16K   | 4   | 0    |
| SRBC      | 228 | 8K   | 8K    | 2   | 0    |
| MSGP      | 241 | 4K   | 4K    | 1   | 0    |
| LPST      | 251 | 8K   | 8K    | 2   | 0    |
| CULE      | 231 | 152K | 152K  | 1   | 0    |
| RPST      | 241 | 4K   | 4K    | 1   | 0    |
| VTCB      | 251 | 305K | 305K  | 0   | 0    |
| RECA      | 0   | 19K  | 19K   | 1   | 0    |
| GSAV      | 231 | 0K   | 0K    | 0   | 0    |
| FEIB      | 231 | 0K   | 0K    | 0   | 0    |
| IEQE      | 0   | 0K   | 0K    | 0   | 0    |
| L56X      | 231 | 4K   | 4K    | 1   | 0    |
| X124      | 241 | 4K   | 4K    | 1   | 0    |
| STAT      | 241 | 4K   | 4K    | 1   | 0    |
| EQEL      | 241 | 0K   | 0K    | 0   | 0    |
| TT24      | 231 | 24K  | 24K   | 6   | 0    |
| LGWA      | 231 | 104K | 104K  | 26  | 0    |
| VWA       | 231 | 8K   | 8K    | 2   | 0    |
| LGWX      | 0   | 0K   | 0K    | 0   | 0    |
| LQB       | 251 | 104K | 104K  | 0   | 0    |
| RCNT      | 251 | 4K   | 4K    | 0   | 0    |
| DDRE      | 0   | 0K   | 0K    | 0   | 0    |
| CCB       | 0   | 0K   | 0K    | 0   | 0    |
| LGND      | 251 | 8K   | 8K    | 2   | 0    |
| USRD      | 251 | 4K   | 4K    | 1   | 0    |
| LS24      | 0   | 2K   | 2K    | 1   | 0    |
| GS24      | 231 | 0K   | 0K    | 0   | 0    |
| CLLE      | 231 | 60K  | 64K   | 16  | 1    |
| QMBA      | 0   | 8K   | 8K    | 1   | 0    |
| AHDR      | 251 | 0K   | 0K    | 0   | 0    |
| XMCI      | 241 | 32K  | 36K   | 9   | 1    |
| DBPB      | 231 | 0K   | 0K    | 0   | 0    |
| LG24      | 0   | 12K  | 12K   | 3   | 0    |
| IAFP      | 231 | 0K   | 0K    | 0   | 0    |
| RACW      | 231 | 0K   | 0K    | 0   | 0    |
| LUB       | 251 | 0K   | 0K    | 0   | 0    |
| TIB       | 251 | 28K  | 28K   | 1   | 0    |
| DESC      | 251 | 4K   | 4K    | 1   | 0    |
| PF62      | 251 | 0K   | 0K    | 0   | 0    |
| QAB       | 251 | 0K   | 0K    | 0   | 0    |
| LCLL      | 0   | 36K  | 36K   | 9   | 0    |
| CBLK      | 251 | 0K   | 0K    | 0   | 0    |
| CBT POOLS |     | GLBL | 1187K | LCL | 658K |

\*91057/132506\*

#### Example 4 for /DISPLAY POOL command

Entry ET:

```
/DISPLAY POOL CIOP SPAP HIOP CESS EMHB FPWP LUMP LUMC
```



Response ET:

```
CIOP BUFFER POOL:
SIZE      16K HIGH      96K LIMIT      999K OVERFLOW      0K
SPAP BUFFER POOL:
SIZE      0K HIGH       0K LIMIT      9999K OVERFLOW      0K
HIOP BUFFER POOL:
SIZE      128K HIGH     128K LIMIT     9999K OVERFLOW      0K
CESS BUFFER POOL:
POOL IS NOT AVAILABLE FOR STATISTICS
EMHB BUFFER POOL:
SIZE      0K HIGH       0K LIMIT      9999K OVERFLOW      0K
FPWP BUFFER POOL:
SIZE      0K HIGH       0K LIMIT      9999K OVERFLOW      0K
LUMP BUFFER POOL:
SIZE      32K HIGH      32K LIMIT      NONE OVERFLOW      0K
LUMC BUFFER POOL:
SIZE      0K HIGH      32K LIMIT      NONE OVERFLOW      0K
*91051/161116*
```

**Example 5 for /DISPLAY POOL command**

Entry ET:

```
/DISPLAY POOL DBAS
```

Response ET:

```
SEQUENTIAL BUFFERING: STATUS = NOT INIT
MAX N.A. FREE N.A. CURR 0K HIGH 0K
OSAM DB BUFFER POOL: ID BSIZE 2K NBUF 4 FX=N/N
LCTREQ 0 NEWBLK 0 ALTREQ 0
PURGRQ 0 FNDIPL 0 BFSRCH 0
RDREQ 0 BFSTLW 0 PURGWR 0
WBSYID 0 WBSYWR 0 WBSYRD 0
WRLSEO 0 WNOBFR 0 ERRORS 00000/00000
OSAM DB BUFFER POOL: ID BSIZE 6K NBUF 4 FX=N/N
LCTREQ 0 NEWBLK 0 ALTREQ 0
PURGRQ 0 FNDIPL 0 BFSRCH 0
RDREQ 0 BFSTLW 0 PURGWR 0
WBSYID 0 WBSYWR 0 WBSYRD 0
WRLSEO 0 WNOBFR 0 ERRORS 00000/00000
OSAM DB BUFFER POOL: ID BSIZE 8K NBUF 4 FX=N/N
LCTREQ 0 NEWBLK 0 ALTREQ 0
PURGRQ 0 FNDIPL 0 BFSRCH 0
RDREQ 0 BFSTLW 0 PURGWR 0
WBSYID 0 WBSYWR 0 WBSYRD 0
WRLSEO 0 WNOBFR 0 ERRORS 00000/00000
OSAM DB BUFFER POOL: BSIZE ALL NBUF 12 OSM= 64K
LCTREQ 0 NEWBLK 0 ALTREQ 0
PURGRQ 0 FNDIPL 0 BFSRCH 0
RDREQ 0 BFSTLW 0 PURGWR 0
WBSYID 0 WBSYWR 0 WBSYRD 0
WRLSEO 0 WNOBFR 0 ERRORS 00000/00000
```

```
VSAM DB BUFFER POOL: ID XXXX BSIZE 1K TYPE D FX=N/N/N
RRBA 0 RKEY 0 BFALT 0
NREC 0 SYNC PT 0 NBUFS 8
VRDS 0 FOUND 0 VWTS 0
HSR-S 0 HSW-S 0 HS NBUFS 0
HS R/W-FAIL 000000/000000 ERRORS 000000/000000
VSAM DB BUFFER POOL: ID XXXX BSIZE 2K TYPE D FX=N/N/N
RRBA 0 RKEY 0 BFALT 0
NREC 0 SYNC PT 0 NBUFS 4
VRDS 0 FOUND 0 VWTS 0
HSR-S 0 HSW-S 0 HS NBUFS 0
HS R/W-FAIL 000000/000000 ERRORS 000000/000000
VSAM DB BUFFER POOL: ID XXXX BSIZE 8K TYPE D FX=N/N/N
RRBA 0 RKEY 0 BFALT 0
NREC 0 SYNC PT 0 NBUFS 4
VRDS 0 FOUND 0 VWTS 0
HSR-S 0 HSW-S 0 HS NBUFS 0
HS R/W-FAIL 000000/000000 ERRORS 000000/000000
VSAM DB BUFFER POOL: BSIZE ALL VS= 48K HS= 0K
RRBA 0 RKEY 0 BFALT 0
NREC 0 SYNC PT 0 NBUFS 16
VRDS 0 FOUND 0 VWTS 0
HSR-S 0 HSW-S 0 HS NBUFS 0
```

HS R/W-FAIL 000000/000000    ERRORS 000000/000000  
\*92120/134346\*

**Example 6 for /DISPLAY POOL command**

Entry ET:

```
/DISPLAY POOL DBB
```

Response ET:

| NAME      | SP# | CURR | MAX   | GETS | FREES |
|-----------|-----|------|-------|------|-------|
| PDIR      | 231 | 36K  | 36K   | 1    | 0     |
| DDIR      | 231 | 28K  | 28K   | 1    | 0     |
| SMB       | 231 | 61K  | 61K   | 1    | 0     |
| BQEL      | 231 | 0K   | 0K    | 0    | 0     |
| IEQE      | 0   | 0K   | 0K    | 0    | 0     |
| EQEL      | 241 | 0K   | 0K    | 0    | 0     |
| DDRE      | 0   | 0K   | 0K    | 0    | 0     |
| CLASS =   | DBB | GLBL | 125K  | LCL  | 0K    |
| CBT POOLS |     | GLBL | 1187K | LCL  | 662K  |

\*91051/161027\*

**Example 7 for /DISPLAY POOL command**

Entry ET:

```
/DISPLAY POOL DCC
```

Response ET:

| NAME      | SP# | CURR | MAX   | GETS | FREES |
|-----------|-----|------|-------|------|-------|
| PCIB      | 0   | 0K   | 0K    | 0    | 0     |
| VTCB      | 251 | 305K | 305K  | 0    | 0     |
| RECA      | 0   | 19K  | 19K   | 1    | 0     |
| LGND      | 251 | 16K  | 16K   | 4    | 0     |
| AHDR      | 251 | 0K   | 0K    | 0    | 0     |
| IAFP      | 231 | 0K   | 0K    | 0    | 0     |
| RACW      | 231 | 0K   | 0K    | 0    | 0     |
| LUB       | 251 | 0K   | 0K    | 0    | 0     |
| TIB       | 251 | 28K  | 28K   | 1    | 0     |
| DESC      | 251 | 0K   | 0K    | 0    | 0     |
| PF62      | 251 | 0K   | 0K    | 0    | 0     |
| QAB       | 251 | 0K   | 0K    | 0    | 0     |
| CBLK      | 251 | 0K   | 0K    | 0    | 0     |
| CLASS =   | DCC | GLBL | 0K    | LCL  | 368K  |
| CBT POOLS |     | GLBL | 1187K | LCL  | 662K  |

\*91051/161038\*

**Example 8 for /DISPLAY POOL command**

Entry ET:

```
/DISPLAY POOL FPDB
```

Response ET:

| POOLNAME            | CISIZE | PBUF  | SBUF  | MAX   | CURRENT | LK | HITS | VALID |
|---------------------|--------|-------|-------|-------|---------|----|------|-------|
| V\$\$\$CFSTRUCTURE1 | 04096  | 00100 | 00010 | 00500 | 00100   | N  | 000% | NA    |
| POOL4               | 04096  | 00010 | 00010 | 00500 | 00010   | Y  | NA   | NA    |

**Example 9 for /DISPLAY POOL command**

Entry ET:

```
/DISPLAY POOL MFP
```

Response ET:

|         |        |       |      |       |       |       |      |      |
|---------|--------|-------|------|-------|-------|-------|------|------|
| MESSAGE | FORMAT | POOL: | SIZE | 49152 | SPACE | 48576 | DIRS | 9011 |
| REQ1    |        | 2     | I/O  | 2     | DIR   | 4     |      |      |

```
WAIT          2  FREE          48432  ERR          0
*91051/172502*
```

**Example 10 for /DISPLAY POOL command**

Entry ET:

```
/DISPLAY POOL MFP CIOP MAIN
```

Response ET:

```
MESSAGE FORMAT POOL:  SIZE          49152  SPACE          48576  DIRS          9011
REQ1              2  I/O              2  DIR              4
WAIT              2  FREE              48432  ERR              0
CIOP BUFFER POOL:
SIZE              96K  HIGH              96K  LIMIT          999K  OVERFLOW          0K
MAIN BUFFER POOL:
SIZE              40K  FREE              40K  HIGH              5K
*91051/160913*
```

**Example 11 for /DISPLAY POOL command**

Entry ET:

```
/DISPLAY POOL MFP STAT
```

Response ET:

```
MFBP BUFFER POOL:
0170 00000000 00000002 00000002 00000000 00000004 00000000 00000000 00000002
0190 00000000 00000000 00000000 00000002 00000000 00000000 00000000 00000000
01B0 00000000 00000001
*91051/172508*
```

**Example 12 for /DISPLAY POOL command**

Entry ET:

```
/DISPLAY POOL PSBP
```

Response ET:

```
PSBP BUFFER POOL:
SIZE              80K  FREE              80K  HIGH              0K
DPSB BUFFER POOL:
SIZE              160K  FREE              160K  HIGH              0K
*91051/161048*
```

**Example 13 for /DISPLAY POOL command**

Entry ET:

```
/DISPLAY POOL QBUF
```

Response ET:

```
MESSAGE QUEUE POOL:  BFRS/SIZE 20/2112          SYS3
ENQ   18  DEQ   18  CAN   52  WAIT   0  I/O   15  ERR   0
QBLKS: MAX # RECORDS AVAIL      5  CUR IN USE      3 = 60 %
SMSGQ: MAX # RECORDS AVAIL  262167  CUR IN USE      4 = 0 %
LMSGQ: MAX # RECORDS AVAIL  524293  CUR IN USE      2 = 0 %
*91051/172432*
```

Explanation: This example shows the **/DISPLAY POOL QBUF** command output in a non-shared-queues environment.

**Example 14 for /DISPLAY POOL command**

Entry ET:

```
/DISPLAY POOL QBUF STAT
```

Response ET:

```
QBUF BUFFER POOL :
0054 00000000 0000005E 00000126 00000001 00000000 00000000 00000007 00000008
0074 00000008 00000000 00000000 00000000 00000000 00000000 00000000 00000000
0094 00000000 00000000 00000000 00000019 00000323 00000000 00000013 00000013
00B4 00000035 00000003 00000004 00000002
*91051/172440*   SYS3
```

### **Example 15 for /DISPLAY POOL command**

Entry ET:

```
/DISPLAY POOL SUM
```

Response ET:

```
CBT POOLS      GLBL      1187K  LCL      662K
CLASS = OSAM   GLBL       28K   LCL       0K
CLASS = GEN    GLBL      724K   LCL       54K
CLASS = DEP    GLBL      216K   LCL       0K
CLASS = DISP   GLBL       88K   LCL      128K
CLASS = DBB    GLBL      125K   LCL       0K
CLASS = DCC    GLBL       0K   LCL      368K
CLASS = FP     GLBL       7K   LCL       0K
*91051/161003*
```

### **Example 16 for /DISPLAY POOL command**

Entry ET:

```
/DISPLAY POOL QBUF
```

Response ET:

```
MESSAGE QUEUE POOL:  BFRS/SIZE 480/2520
ENQ  255  DEQ    2  CAN    82  WAIT    0  I/O    28  ERR    0
QBLKS:  MAX # RECORDS AVAIL    50176  CUR IN USE    3 = 0 %
MSGQ:   MAX # RECORDS AVAIL    52416  CUR IN USE    0 = 0 %
LMSGQ:  MAX # RECORDS AVAIL    20160  CUR IN USE   254 = 1 %
CUR BUFFER INUSE COUNT          379
BUFFER INUSE HIGH WATER MARK    379  I
*13091/160847*
```

Explanation: This example shows the **/DIS POOL QBUF** command output in a shared-queues environment.

#### **Related concepts**

[Monitoring VSAM buffers \(Database Administration\)](#)

#### **Related reference**

[QUERY POOL command \(Commands\)](#)

## **/DISPLAY PSB command**

Use the **/DISPLAY PSB** command to display which transactions the PSBs are processing, any routing code associated with the transactions, the databases being accessed, and the type of access.

Subsections:

- [“Environment” on page 649](#)
- [“Syntax” on page 649](#)
- [“Usage notes” on page 649](#)
- [“Equivalent IMS type-2 commands” on page 649](#)
- [“Examples” on page 649](#)

## Environment

The **/DISPLAY PSB** command is valid in DB/DC, DBCTL, and DCCTL environments.

## Syntax

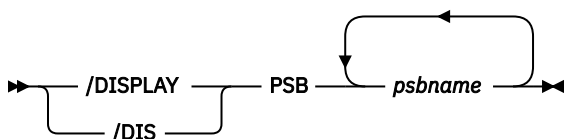

## Usage notes

For HSSP PSBs, the letter H is appended to the access intent under the ACCESS heading.

To display the status of PSBs, use the **/DISPLAY PGM** command.

## Equivalent IMS type-2 commands

The following table shows variations of the **/DISPLAY PSB** command and the IMS type-2 commands that perform similar functions.

Table 300. Type-2 equivalents for the /DISPLAY PSB command

| Task   | /DISPLAY PSB command        | Similar IMS type-2 command                     |
|--|-----------------------------|--|
| Displays transactions, routing codes, and databases associated with a PSB. | /DISPLAY PSB <i>psbname</i> | QUERY PGM NAME( <i>pgmname</i> )<br>SHOW(DB)   |
|  |                             | QUERY PGM NAME( <i>pgmname</i> )<br>SHOW(RTC)  |
|  |                             | QUERY PGM NAME( <i>pgmname</i> )<br>SHOW(TRAN) |

## Examples

Entry ET:

```
/DISPLAY PSB DDLTLM06 DDLTLM07
```

Response ET:

| PSB - NAME | TRANCODE | RTCODE   | DBD - NAME | ACCESS   |          |          |     |
|------------|----------|----------|------------|----------|----------|----------|-----|
| DDLTLM06   | TXCDLM06 | TXCDLM06 | MSDBLM01   | R/W      |          |          |     |
|            |          |          | MSDBLM02   | R/W      |          |          |     |
|            |          |          | MSDBLM03   | R/W      |          |          |     |
|            |          |          | MSDBLM01   | R/W      |          |          |     |
|            |          |          | MSDBLM04   | R/W      |          |          |     |
|            |          |          | MSDBLM04   | R/W      |          |          |     |
|            |          |          | MSDBLM05   | R/W      |          |          |     |
|            |          |          | MSDBLM05   | R/W      |          |          |     |
|            |          |          | MSDBLM06   | R/W      |          |          |     |
|            |          |          | MSDBLM06   | R/W      |          |          |     |
|            |          |          | MSDBLM06   | R/W      |          |          |     |
|            |          |          | MSDBLM06   | R/O      |          |          |     |
|            |          |          | DDLTLM07   | TXCDLM07 | TXCDLM07 | MSDBLM01 | R/W |
|            |          |          |            |          |          | MSDBLM02 | R/W |
| MSDBLM03   | R/W      |          |            |          |          |          |     |

|                |          |     |
|----------------|----------|-----|
|                | MSDBLM01 | R/O |
|                | MSDBLM04 | R/W |
|                | MSDBLM04 | R/W |
|                | MSDBLM05 | R/W |
|                | MSDBLM05 | R/W |
|                | MSDBLM06 | R/W |
|                | MSDBLM06 | R/W |
|                | MSDBLM06 | R/W |
|                | MSDBLM06 | R/O |
|                | MSDBLM07 | R/W |
| *91068/111601* |          |     |

**Related reference**

[QUERY PGM command \(Commands\)](#)

## **/DISPLAY PTERM command**

Use the **/DISPLAY PTERM** command to display physical terminals with specific attributes. The **/DISPLAY PTERM** command can be specified without an associated LINE keyword on **/DISPLAY** when PTERM is used with the special "attribute" parameter.

Subsections:

- [“Environment” on page 650](#)
- [“Syntax” on page 650](#)
- [“Usage notes” on page 651](#)
- [“Examples” on page 652](#)

### **Environment**

The **/DISPLAY PTERM** command is valid in DB/DC and DCCTL environments.

### **Syntax**

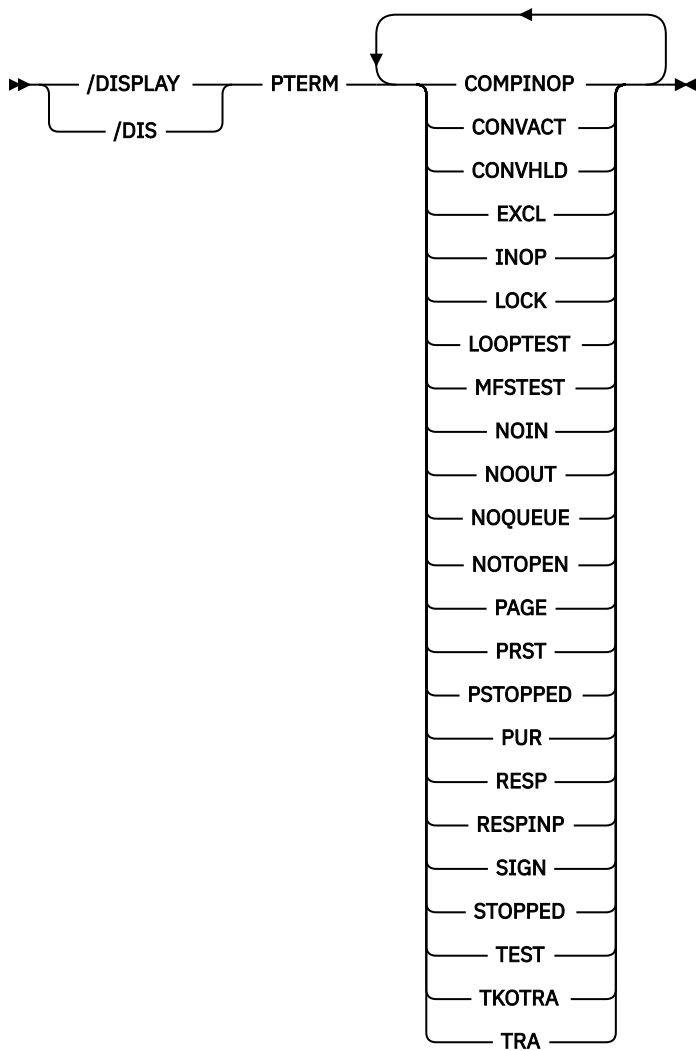

## Usage notes

Physical terminals are selected for display based on the attribute or attributes specified. The attribute display format is the same as the standard LINE/PTERM display. Attributes usually correspond to the conditions displayed for line/physical terminals.

The attributes that can be specified with the PTERM keyword are listed in the following table. For example, **/DISPLAY PTERM TRACE** displays all physical terminals that are currently being traced.

Table 301. /DISPLAY PTERM command attributes

| Attributes List #1                                   | Attributes List #2                                   |
|--|--|
| COMPINOP   | CONVACT (Corresponds to the NODE condition CONV-ACT) |
| CONVHLD (Corresponds to the NODE condition CONV-HLD) | EXCL   |
| INOP   | LOCK   |
| LOOPTEST   | MFSTEST  |
| NOIN   | NOOUT  |
| NOQUEUE  | NOTOPEN  |

Table 301. /DISPLAY PTERM command attributes (continued)

| Attributes List #1 | Attributes List #2 |
|--------------------|--------------------|
| PAGE               | PRST               |
| PSTOPPED           | PUR                |
| RESP               | RESPINP            |
| SIGN               | STOPPED            |
| TEST               | TKOTRA             |
| TRA                |                    |

### Examples

This example shows the display of all physical terminals that are being traced.

Entry ET:

```
/DISPLAY PTERM TRA
```

Response ET:

```

LIN/PTE  TYPE  ADDR  RECD  ENQCT  DEQCT  QCT  SENT  IMS1
  2-   1 RDR/PTR  ****      0      0      0      0      0 STOPPED INOP NOTOPEN TRA
*13128/111659*
```

## /DISPLAY Q command

Use the **/DISPLAY Q** command to display the message queues according to classes and priority levels.

Subsections:

- [“Environment” on page 652](#)
- [“Syntax” on page 653](#)
- [“Keywords” on page 653](#)
- [“Examples” on page 653](#)

### Environment

The following table lists the environments (DB/DC, DBCTL, and DCCTL) in which you can use the command and keywords.

Table 302. Valid environments for the /DISPLAY Q command and keywords

| Command / Keywords | DB/DC | DBCTL | DCCTL |
|--------------------|-------|-------|-------|
| <b>/DISPLAY</b>    | X     | X     | X     |
| BALGRP             | X     |       | X     |
| CLASS              | X     |       | X     |
| Q                  | X     |       | X     |
| PRIORITY           | X     | X     | X     |
| TRANSACTION        | X     |       | X     |



## Syntax

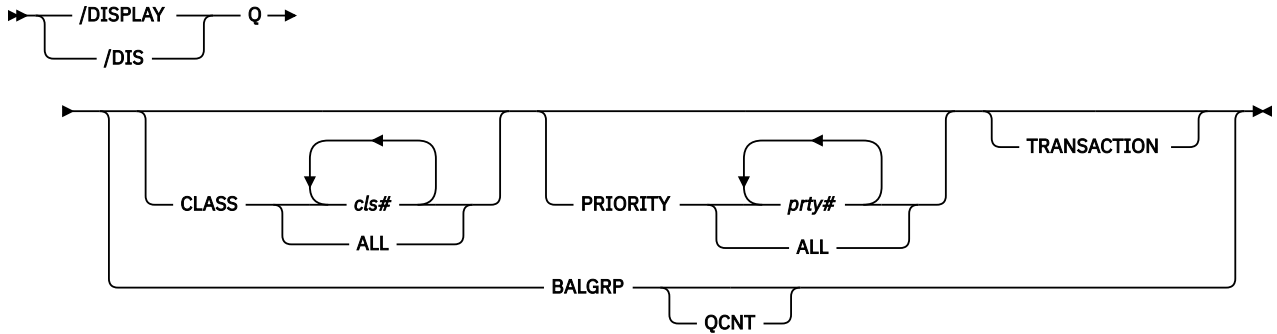

## Keywords

The following keywords can be specified for the **/DISPLAY Q** command:

### **BALGRP**

Displays queue counts of the Fast Path load balancing group queues.

### **CLASS**

Displays queues for specified classes.

### **PRIORITY**

Displays queues for specified priorities.

### **QCNT**

Specifies that global queue count information is to be displayed for Fast Path load balancing groups. If QCNT is not specified, only local queue counts are displayed; when it is specified, no local queue counts are displayed.

This keyword is valid only in a shared-queues environment.

### **TRANSACTION**

Displays queues for transactions that are ready to run. DFSPIC is displayed as psbname for CPI Communications driven transactions that have not issued a DL/I call to allocate a PSB.

Combinations of the CLASS, PRIORITY, and TRANSACTION keywords enable classes, priority levels within classes, transactions within priority levels, and message counts to be displayed on an as-needed basis.

## Examples

The following are examples of the **/DISPLAY Q** command.

### **Example 1 for /DISPLAY Q command**

Entry ET:

```
/DISPLAY Q
```

Response ET:

```
CLS CT  PTY CT  MSG CT  TRAN CT
  3      5      28      8
*90253/103811*
```

Entry ET:

```
/DISPLAY Q BALGRP
```

Response ET:

| BALGRP  | NO.RGNS | MSG CT | ENQ COUNT | DEQ COUNT |
|---------|---------|--------|-----------|-----------|
| DDLTM06 | 1       | 1      | 2         | 1         |
| DDLTM07 | 1       | 0      | 0         | 0         |

\*91068/112000\*

**Explanation:** In a shared-queues environment, the DEQ COUNT column shows the number of messages processed by the local IMS. This can be a message that is entered by the local IMS system or a sharing IMS system in the IMSplex.

Entry ET:

```
/DISPLAY Q BALGRP QCNT
```

Response ET:

| BALGRP | GBLQCT |
|--------|--------|
| SMQFP1 | 2      |
| SMQFP2 | 3      |

\*96197/174618\*

Entry ET:

```
/DISPLAY Q CLASS ALL
```

Response ET:

| CLS | PTY CT | MSG CT | TRAN CT |
|-----|--------|--------|---------|
| 1   | 1      | 2      | 1       |
| 2   | 1      | 2      | 1       |
| 3   | 1      | 4      | 1       |

\*90253/103855\*

Entry ET:

```
/DISPLAY Q CLASS 1 2
```

Response ET:

| CLS | PTY CT | MSG CT | TRAN CT |
|-----|--------|--------|---------|
| 1   | 1      | 2      | 1       |
| 2   | 1      | 2      | 1       |

\*90253/103913\*

Entry ET:

```
/DISPLAY Q PRIORITY ALL
```

Response ET:

| CLS | PTY | MSG CT | TRAN CT |
|-----|-----|--------|---------|
| 1   | 9   | 2      | 1       |
| 2   | 1   | 2      | 1       |
| 3   | 5   | 4      | 1       |

\*90253/103945\*

Entry ET:

```
/DISPLAY Q PRIORITY 10
```

Response ET:

```
CLS     PTY     MSG CT  TRAN CT
 4       10      18      3
*90253/1104016
```

Entry ET:

```
/DISPLAY Q CLASS 4 PRIORITY 10
```

Response ET:

```
CLS     PTY     MSG CT  TRAN CT
 4       10      18      3
*90309/122418*
```

Entry ET:

```
/DISPLAY Q TRANSACTION
```

Response ET:

```
CLS     PTY     MSG CT  TRAN     PSBNAME
 3       10      3     CLOSE   DFSSAM05
 4       10      2     ADDPART DFSSAM04
 4       10      4     PART    DFSSAM02
 5       7       1     ADDINV  DFSSAM04
 5       10     5     DLETINV DFSSAM04
*90243/110324*
```

Entry ET:

```
/DISPLAY Q CLASS 3 5 TRANSACTION
```

Response ET:

```
CLS     PTY     MSG CT  TRAN     PSBNAME
 3       10      3     CLOSE   DFSSAM05
 5       7       1     ADDINV  DFSSAM04
 5       10     5     DLETINV DFSSAM04
*90243/110332*
```

Entry ET:

```
/DISPLAY Q CLASS 4 PRIORITY 10 11 TRANSACTION
```

Response ET:

```
CLS     PTY     MSG CT  TRAN     PSBNAME
 4       10      2     ADDPART DFSSAM04
 4       10      4     PART    DFSSAM02
*90243/110343*
```

Entry ET:

```
/DISPLAY Q CLASS 1 2 3 PRIORITY 1
```

Response ET:

```
CLS     PTY     MSG CT  TRAN CT
 1       1       2       1
 2       1       2       1
 3       1       4       1
*90253/104321*
```

### **Example 2 for /DISPLAY Q command**

Entry ET:

```
/DISPLAY QUEUE TRANSACTION
```

Response ET:

```
CLS   PTY   MSG  CT   TRAN   PSBNAME
20    5     2     2    TPN1   DFSCPIC
20    2     5     5    TPN2   SAAPSB1
22    3     7     7    TPN3   SAAPSB2
*90332/114253*
```

## **/DISPLAY QCNT command**

Use the **/DISPLAY QCNT** command to display global queue information for the specified resource type.

The resource type can be APPC, BALGRP, LTERM, OTMA, REMOTE, or TRANSACTION. This command displays all the queues for the resource type with at least one message whose message age is greater than the message age value specified.

The **/DISPLAY QCNT OTMA** command displays the global queue counts for all OTMA outbound queues, including those messages that are queued on a transaction pipe that is defined to a super member. Instead of displaying the queue name that was used to queue the OTMA output messages, the character string 'TMSTMP-' is displayed. If the member is a regular member, the IMS ID of the IMS to which the messages have affinity is displayed following the 'TMSTMP-' character string. If the member is a super member, the IMS ID field is left blank since messages queued to the super member do not have affinity to any IMS.

This count represents the message counts of messages that can be processed by the IMS system where the command is issued. This count includes messages that can be processed by any IMS system (messages with no affinity), plus messages that can be processed by the IMS system where the command is issued (messages with an affinity to the IMS system that issued the command).

Subsections:

- [“Environment” on page 656](#)
- [“Syntax” on page 657](#)
- [“Keywords” on page 657](#)
- [“Usage notes” on page 657](#)
- [“Equivalent IMS type-2 commands” on page 658](#)
- [“Output fields” on page 658](#)
- [“Examples” on page 658](#)

### **Environment**

The following table lists the environments (DB/DC, DBCTL, and DCCTL) in which you can use the command and keywords.

*Table 303. Valid environments for the /DISPLAY QCNT command and keywords*

| <b>Command / Keywords</b> | <b>DB/DC</b> | <b>DBCTL</b> | <b>DCCTL</b> |
|---------------------------|--------------|--------------|--------------|
| <b>/DISPLAY</b>           | X            | X            | X            |
| APPC                      | X            |              | X            |
| BALGRP                    | X            |              | X            |
| LTERM                     | X            |              | X            |
| MSGAGE                    | X            |              | X            |
| OTMA                      | X            |              | X            |
| QCNT                      | X            |              | X            |

Table 303. Valid environments for the /DISPLAY QCNT command and keywords (continued)

| Command / Keywords | DB/DC | DBCTL | DCCTL |
|--------------------|-------|-------|-------|
| REMOTE             | X     |       | X     |
| TRANSACTION        | X     |       | X     |

## Syntax

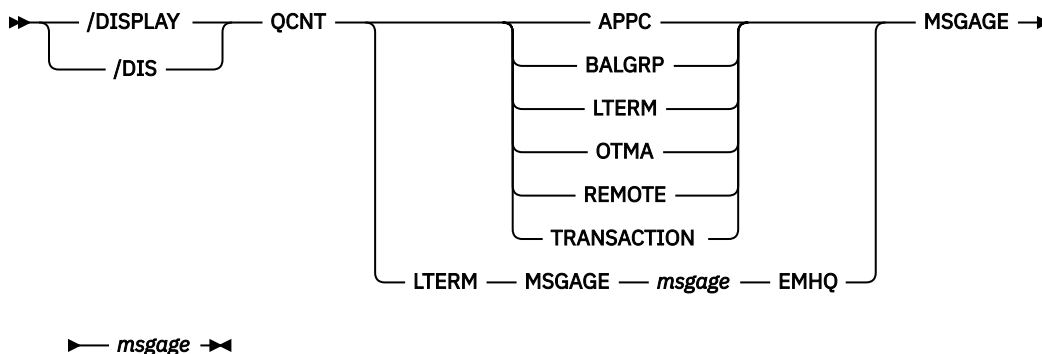

## Keywords

The following list describes the resource types allowed:

### APPC

Specifies that global information for all APPC outbound queues is to be displayed.

For messages that are placed on the shared queues using a side information entry name, the side information entry name is returned in the LUNAME field and the character string, DFSSIDE, is returned in the TPNAM field.

### BALGRP

Specifies that global information for LTERMs and MSNAMEs is to be displayed.

### LTERM

Specifies that global information for LTERMs and MSNAMEs is to be displayed.

### MSGAGE

Specifies the message age in number of days (0-365). Only those queues with messages older than or equal to the value are displayed. The resource name and the time when the message was placed on the shared queues are displayed.

If you specify MSGAGE 0, all resources (queues) are displayed.

### OTMA

Specifies that global information for all OTMA outbound queues is to be displayed.

### REMOTE

Specifies that global information for remote transactions and remote LTERMs is to be displayed.

### TRANSACTION

Specifies that global information for transactions is to be displayed, not including transactions that are suspended.

## Usage notes

This command is valid only in a shared-queues environment.

**Recommendation:** When you issue this command, IMS reads every message for the resource type. To minimize the performance impact, issue this command only when necessary.

## Equivalent IMS type-2 commands

The following table shows variations of the **/DISPLAY QCNT** command and the IMS type-2 commands that perform similar functions.

Table 304. Type-2 equivalents for the **/DISPLAY QCNT** command

| Task   | <b>/DISPLAY QCNT</b> command        | Similar IMS type-2 command   |
|--|-------------------------------------|------------------------------|
| Displays lterms with messages that are older than the specified age (shared queues). | <b>/DISPLAY QCNT LTERM MSGAGE x</b> | <b>QUERY LTERM MSGAGE(x)</b> |

## Output fields

The output fields are displayed by the **/DISPLAY QCNT** command:

### QUEUENAME

1-8 byte queue name.

If the output is the result of a **/DISPLAY QCNT APPC MSGAGE** or a **/DISPLAY QCNT OTMA MSGAGE** command, the value displayed for the queue name is the character string 'TMSTMP' followed by the IMSID (or the first seven bytes of the RSENAME if XRF capable) of the IMS to which the output messages have affinity.

### QCNT-TOTAL

Total count of messages on the queue.

### QCNT-AGED

Count of messages with a message age greater than or equal to the message age specified. This count does not include messages whose age is less than the message age specified.

### TSTMP-OLD

The time stamp of the oldest message for the queue name on the shared queue.

### TSTMP-NEW

The time stamp of the newest message for the queue name on the shared queue.

**Note:** The time stamp is the time when the message is put on the shared queues by CQS. These time stamps can be used to select records from the CQS log or the IMS log. Because this is a CQS generated time stamp, it might not correspond to the time stamp for the same message on the IMS log as logging a message in IMS and logging the same message in CQS are separate events.

## Examples

The following are examples of the **/DISPLAY QCNT** command.

### Example 1 for the **/DISPLAY QCNT** command

Entry ET:

```
/DISPLAY QCNT LTERM MSGAGE 5
```

Response ET:

| QUEUENAME | QCNT-TOTAL | QCNT-AGED | TSTMP-OLD    | TSTMP-NEW    |
|-----------|------------|-----------|--------------|--------------|
| TESTLSEA  | 1          | 1         | 95280/132006 | 95280/132006 |
| LTERMABC  | 4          | 4         | 95274/083000 | 95275/091836 |

```

LTERMA                100          100    95275/080000 95281/212224
*95290/132006*

```

**Example 2 for the /DISPLAY QCNT command**

Entry ET:

```

/DIS QCNT APPC MSGAGE 0

```

Response ET:

```

QUEUENAME      QCNT-TOTAL    QCNT-AGED    TSTMP-OLD    TSTMP-NEW
TMSTMP- SYS3          16           16    02192/080833 02192/080928
  LUNAME: L62MVS1
  TPNAME: TPNAME123
TMSTMP- IMS2          12           12    02192/080620 02192/080658
  LUNAME: NETWRKID.L62IMS1
  TPNAME: ABCDEFGHIJKLMNOPQRSTUVWXYZ
*02192/081543*

```

**Example 3 for the /DISPLAY QCNT command**

Entry ET:

```

/DISPLAY QCNT TRANSACTION MSGAGE 5

```

Response ET:

```

QUEUENAME      QCNT-TOTAL    QCNT-AGED    TSTMP-OLD    TSTMP-NEW
TRANA              20            20    95200/132006 95280/132006
TRANBBBB           4              4    95274/083000 95275/091836
TRANSACA          220            220    95275/080000 95281/212224
TRANSDDD           13              0    95290/101455 95290/101456
TRANSEEE           55              13    95277/152118 95290/114317
*95290/132006*

```

**Example 4 for the /DISPLAY QCNT command**

Entry ET:

```

/DIS QCNT OTMA MSGAGE 0

```

Response ET:

```

QUEUENAME      QCNT-TOTAL    QCNT-AGED    TSTMP-OLD    TSTMP-NEW
TMSTMP- SYS3          24            24    05038/083745 05038/083745
  TMEMBER: HWS003
  TPIPE: TPIPE1
TMSTMP-          2              2    05038/084022 05038/084022
  TMEMBER: SM01
  TPIPE: TPIPE1
TMSTMP-          5              5    05038/092537 05038/092537
  TMEMBER: SM01
  TPIPE: TPIPE2
TMSTMP-          16             16    05038/072311 05038/072311
  TMEMBER: SM01
  TPIPE: TPIPE3
*02192/083757*

```

Explanation: In this example, 24 messages are queued on TPIPE1 for member HWS003. For super member SM01, two messages are queued on TPIPE1, five messages are queued on TPIPE, and sixteen messages are queued on TPIPE3.

**Example 5 for the /DISPLAY QCNT command**

Entry ET:

```

/DIS QCNT LTERM MSGAGE 0 EMHQ

```

Response ET:

| QUEUENAME      |      | QCNT-TOTAL | QCNT-AGED | TSTMP-OLD    |
|----------------|------|------------|-----------|--------------|
| TSTMP-NEW      | SYS3 |            |           |              |
| IMSUS01        |      | 1          | 1         | 04309/103912 |
| 04309/103912   | SYS3 |            |           |              |
| IMSUS02        |      | 1          | 1         | 04309/105127 |
| 04309/105127   | SYS3 |            |           |              |
| *04310/132127* | SYS3 |            |           |              |

### Related reference

[QUERY LTERM command \(Commands\)](#)

## /DISPLAY RECOVERY command

Use the **/DISPLAY RECOVERY** command to display the recovery process in progress.

It also displays the list of database data sets and areas being recovered by an online database recovery service. The database data sets and areas are displayed as part of a recovery list, which is a set of database data sets, areas, or both processed by an online database recovery service in a single recovery instance. The **/DISPLAY RECOVERY** command also shows the status of one or all of the recovery lists that exist.

Subsections:

- [“Environment” on page 660](#)
- [“Syntax” on page 660](#)
- [“Keywords” on page 660](#)
- [“Usage notes” on page 661](#)
- [“Recovery list information” on page 661](#)
- [“Recovery progress information” on page 662](#)
- [“Recovery list entry information” on page 662](#)
- [“Output fields” on page 662](#)
- [“Examples” on page 663](#)

### Environment

The **/DISPLAY RECOVERY** command is valid in DB/DC and DBCTL environments.

### Syntax

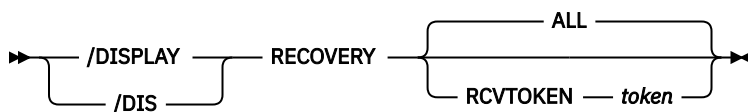

### Keywords

The following keywords can be specified for the **/DISPLAY RECOVERY** command

#### ALL

An optional parameter that displays all the recovery list information and the recovery progress information. No recovery list entry information is displayed.

#### RCVTOKEN

An optional parameter that displays the recovery token associated with the specific recovery list. The recovery list information and recovery progress information for the specific list display with the



recovery list entry information, including the database data set and areas contained in the recovery list.

**token**

Specifies the unique recovery token associated with the recovery list. This token can be up to eight characters in length. If RCVTOKEN is specified, *token* must be supplied.

## Usage notes

If an online database recovery service is executing in an IMS DB/DC control region, the **/DISPLAY RECOVERY** command can be issued from LTERMs, automated operator (AO) application programs, the IMS Master Terminal (MTO), or the z/OS master console and secondary console.

If an online database recovery service is running in an IMS DBCTL region, the **/DISPLAY RECOVERY** command can be issued by programs using the IMS DBCTL AOI or the z/OS master console and secondary console.

## Recovery list information

This section displays the status of one or more recovery lists. The status includes the following information:

### TOKEN

This shows the recovery list token. If **/DIS RECOVERY ALL** is issued and no recovery lists exist, NO LISTS is displayed. If IMS is unable to obtain recovery list information from the recovery facility, UNAVAIL is displayed.

### STATUS

The current status of the recovery list. The status is one of the following:

#### FORMING

A **/RECOVER START** command has not been issued.

#### STARTED

A **/RECOVER START** command has been issued. Recovery processing started but has not completed.

#### UNKNOWN

No list with the given token can be found.

#### STOPPING

A **/REC STOP ALLENT** command was issued.

### ERROR

The choices are ABORT or CONT. These are the action options in case an error is encountered.

### REC TYPE

Indicates the type of recovery being processed. The type is one of the following:

#### FULL

A full recovery is processing.

#### TSR

A time stamp recovery is processing. This occurs when RCVTIME was specified on the **/RECOVER START** command, but PITR was not specified.

#### PITR

A time-stamp recovery is processing with the point-in-time recovery (PITR) option. This occurs when RCVTIME is specified on the **/RECOVER START** command with PITR.

#### N/A

Recovery has not been started. The type is undefined.

### PROC

The values that may appear reflect the recovery progress in two phases of processing: reading log data sets and restoring image copy data. The format of the entries are as follows:

- nnnn of mmmm LOGS READ
- nnnn of mmmm RESTORED
- COMPLETE - this state will only appear for a few seconds following the completion of restoration of the last DBDS and termination of the recovery list.
- NOT STARTED - The recovery list is ready for processing or for additional updates.
- routing time - if an online database recovery service is being used.

#### **IC#**

Indicates the primary image copy will be used if an image copy is to be used during recovery.

#### **SOURCE**

The primary copy as contained in the RECON is used for recovery.

### **Recovery progress information**

This section displays status of the recovery in progress, if there is one. The section is omitted if no recovery is in progress. The status includes the following information:

#### **TOKEN**

The recovery list token.

#### **LAST PROCESSED**

The time stamp of the last log record processed by the recovery. The time is displayed in local time.

#### **RCVTIME**

The RCVTIME value specified on the **/RECOVER START** command or N/A if none was specified. The time is displayed in local time.

### **Recovery list entry information**

This section displays the list of database data sets and areas in the given recovery list. The status includes the following information:

#### **DATABASE DATA SET**

For full function, this is the DB name and DD name of the database data set. For Fast Path, it is the area name. If there are multiple area data sets for the area, the string '(MADS)' will also be displayed.

#### **START OPTION**

This shows the start option that was specified on the **/RECOVER ADD** or **/RECOVER START** command or taken from the system default. The values can be STALOCAL, STAGLOBAL, or OFFLINE.

#### **STATUS**

This indicates the status of the database data set or area. The status can be one of the following:

##### **FAILED**

An error occurred for this database data set or area during recovery.

##### **STOPPED**

A **/RECOVER STOP** command was entered to stop recovery processing for the database data set or area.

##### **NORMAL**

Recovery is in progress or pending for the database data set or area.

##### **INVALID**

DBRC no longer contains information about this database data set or area.

#### **AUTH SSID**

A list of SSIDs that are still authorized to the database data set or area. **NONE** displays if no IMS is authorized to the database data set or area. If recovery is in progress, **N/A** displays.

### **Output fields**

The **/DISPLAY RECOVERY** command output is divided into three sections.

- Recovery List Information
- Recovery Progress Information
- Recovery List Entry Information

### Examples

The following are examples of the **/DISPLAY RECOVERY** command.

#### **Example 1 for /DISPLAY RECOVERY command**

In this example, a **/DISPLAY RECOVERY** command is issued before a **/RECOVER START** for RCVTOKEN RECOV1 is issued.

Entry ET:

```
/DISPLAY RECOVERY RCVTOKEN RECOV1
```

Response ET:

```
**** RECOVERY LIST INFORMATION ****
TOKEN  STATUS  ERROR- REC TYPE  PROC  IC#  SOURCE
RECOV1 FORMING N/A    N/A    N/A    N/A
**** RECOVERY LIST ENTRY INFORMATION ****
DATABASE DATA SET  START OPTION  STATUS  AUTH SSID
DB23AR1             STAGLOBAL    NORMAL  NONE
DB23AR2             OFFLINE      NORMAL  NONE
DB23AR3             STAGLOBAL    NORMAL  NONE
DB23AR4             STALOCAL    NORMAL  NONE
DB23AR5             STALOCAL    NORMAL  NONE
DHVNTZ02 HIDAM     STAGLOBAL    NORMAL  NONE
DIVNTZ02 DBHVSAM1  OFFLINE     NORMAL  NONE
DXVNTZ02 XDLBT04I  STALOCAL    NORMAL  NONE
*03127/153515*
```

#### **Example 2 for /DISPLAY RECOVERY command**

In Example 2, a **/DISPLAY RECOVERY** command is issued before a **/RECOVER START** for RCVTOKEN RECOV1 is issued. Some of the database data sets in the recovery list are still authorized to two IMS systems.

Entry ET:

```
/DISPLAY RECOVERY RCVTOKEN RECOV1
```

Response ET:

```
**** RECOVERY LIST INFORMATION ****
TOKEN  STATUS  ERROR- REC TYPE  PROC  IC#  SOURCE
RECOV1 FORMING N/A    N/A    N/A    N/A
**** RECOVERY LIST ENTRY INFORMATION ****
DATABASE DATA SET  START OPTION  STATUS  AUTH SSID
DB23AR1             STAGLOBAL    NORMAL  NONE
DB23AR2             OFFLINE      NORMAL  NONE
DB23AR3             STAGLOBAL    NORMAL  NONE
DB23AR4             STALOCAL    NORMAL  NONE
DB23AR5             STALOCAL    NORMAL  NONE
DHVNTZ02 HIDAM     STAGLOBAL    NORMAL  IMS1
                    IMS2
DIVNTZ02 DBHVSAM1  OFFLINE     NORMAL  IMS1
                    IMS2
DXVNTZ02 XDLBT04I  STALOCAL    NORMAL  IMS1
                    IMS2
                    *03127/153515*
```

#### **Example 3 for /DISPLAY RECOVERY command**

In this example, a **/DISPLAY RECOVERY** command is issued after a **/RECOVER START RCVTOKEN RECOV1 ERRORCONT** command was issued when the IMS Database Recovery Facility is the recovery

product being used. In this case, all logs have been processed and three of the eight data sets have been restored.

Entry ET:

```
/DISPLAY RECOVERY RCVTOKEN RECOV1
```

Response ET:

```
**** RECOVERY LIST INFORMATION ****
TOKEN   STATUS   ERROR- REC TYPE  PROC IC#  SOURCE
RECOV1  STARTED  CONT  FULL      RTDB  0     PRI
**** RECOVERY PROGRESS INFORMATION ****
TOKEN   PROGRESS INFORMATION      RCVTIME
RECOV1  0003 OF 0008 RESTORED      N/A
**** RECOVERY LIST ENTRY INFORMATION ****
DATABASE DATA SET  START OPTION  STATUS  AUTH SSID
DB23AR1             STAGLOBAL   NORMAL  N/A
DB23AR2             OFFLINE     NORMAL  N/A
DB23AR3             STAGLOBAL   NORMAL  N/A
DB23AR4             STALOCAL   NORMAL  N/A
DB23AR5             STALOCAL   NORMAL  N/A
DHVNTZ02 HIDAM    STAGLOBAL   NORMAL  N/A
DIVNTZ02 DBHVSAM1 OFFLINE     NORMAL  N/A
DXVNTZ02 XDLBT04I STALOCAL   NORMAL  N/A *03127/153515*
```

#### Example 4 for /DISPLAY RECOVERY command

In the following example, a **/DISPLAY RECOVERY** command is issued after a **/RECOVER START ERRORCONT** command was issued. Also a **/RECOVER STOP** command was issued for DHVNTZ02, and DB23AR2 failed during a recovery.

Entry ET:

```
/DISPLAY RECOVERY RCVTOKEN RECOV1
```

Response ET:

```
**** RECOVERY LIST INFORMATION ****
TOKEN   STATUS   ERROR- REC TYPE  PROC IC#  SOURCE
RECOV1  STARTED  CONT  FULL      RTDB  0     PRI
**** RECOVERY PROGRESS INFORMATION ****
TOKEN   PROGRESS INFORMATION      RCVTIME
RECOV1  2000.251 07:57:00.3      N/A
**** RECOVERY LIST ENTRY INFORMATION ****
DATABASE DATA SET  START OPTION  STATUS  AUTH SSID
DB23AR1             STAGLOBAL   NORMAL  N/A
DB23AR2             OFFLINE     FAILED  N/A
DB23AR3             STAGLOBAL   NORMAL  N/A
DB23AR4             STALOCAL   NORMAL  N/A
DB23AR5             STALOCAL   NORMAL  N/A
DHVNTZ02 HIDAM    STAGLOBAL   STOPPED N/A
DIVNTZ02 DBHVSAM1 OFFLINE     NORMAL  N/A
DXVNTZ02 XDLBT04I STALOCAL   NORMAL  N/A *03127/153515*
```

#### Example 5 for /DISPLAY RECOVERY command

In this example, a **/DISPLAY RECOVERY ALL** command is issued after three lists are created using the IMS Database Recovery Facility recovery product. In this case, the IMS Database Recovery Facility has processed 76 of the 126 logs that will need to be read. One of the lists (RECOV2) is undergoing TSR.

Entry ET:

```
/DISPLAY RECOVERY ALL
```

Response ET:

```
**** RECOVERY LIST INFORMATION ****
TOKEN   STATUS   ERROR- REC TYPE  PROC IC#  SOURCE
RECOV1  FORMING  N/A   N/A      N/A   N/A
RECOV2  STARTED  CONT  TSR      RTDB  0     PRI
RECOV3  FORMING  N/A   N/A      N/A   N/A
**** RECOVERY PROGRESS INFORMATION ****
```

```
TOKEN    PROGRESS INFORMATION    RCVTIME
RECOV2  0076 OF 0125 LOGS READ  2003.127 08:30:00.0
**** RECOVERY LIST ENTRY INFORMATION ****
DATABASE DATA SET  START OPTION  STATUS  AUTH SSID
DB23AR1              STAGLOBAL  NORMAL  N/A
DB23AR2              OFFLINE   NORMAL  N/A
DB23AR3              STAGLOBAL  NORMAL  N/A
DB23AR4              STALOCAL  NORMAL  N/A
DB23AR5              STALOCAL  NORMAL  N/A
DHSVNTZ02 HIDAM      STAGLOBAL  NORMAL  N/A
DIVNTZ02 DBHVSAM1    OFFLINE   NORMAL  N/A
DXVNTZ02 XDLBT04I   STALOCAL  NORMAL  N/A *03127/153515*
```

**Example 6 for /DISPLAY RECOVERY command**

In this example, a **/DISPLAY RECOVERY** command is issued after three lists are created. No other parameters are specified.

Entry ET:

```
/DISPLAY RECOVERY ALL
```

Response ET:

```
**** RECOVERY LIST INFORMATION ****
TOKEN  STATUS  ERROR- REC TYPE  PROC  IC#  SOURCE
RECOV1  FORMING  N/A    N/A      N/A   N/A   N/A
RECOV2  FORMING  N/A    N/A      N/A   N/A   N/A
RECOV3  FORMING  N/A    N/A      N/A   N/A   N/A
*03127/153515*
```

**Example 7 for /DISPLAY RECOVERY command**

In this example, a **/DISPLAY RECOVERY ALL** command is issued when no recovery lists exist.

Entry ET:

```
/DISPLAY RECOVERY ALL
```

Response ET:

```
**** RECOVERY LIST INFORMATION ****
TOKEN  STATUS  ERROR- REC TYPE  PROC  IC#  SOURCE
**** RECOVERY LIST INFORMATION ****
TOKEN  STATUS  ERROR- REC TYPE  PROC  IC#  SOURCE
NO LISTS
*03127/153515*
```

**Example 8 for /DISPLAY RECOVERY command**

In this example, a **/DISPLAY RECOVERY RCVTOKEN RECOV3** is issued when the RCVTOKEN does not exist.

Entry ET:

```
/DISPLAY RECOVERY RCVTOKEN RECOV3
```

Response ET:

```
**** RECOVERY LIST INFORMATION ****
TOKEN  STATUS  ERROR- REC TYPE  PROC  IC#  SOURCE
**** RECOVERY LIST INFORMATION ****
TOKEN  STATUS  ERROR- REC TYPE  PROC  IC#  SOURCE
RECOV3  UNKNOWN  N/A    N/A      *03127/153515*
```

## /DISPLAY RTCODE command

Use the **/DISPLAY RTCODE** command to display the status of Fast Path routing codes, the PSB using the routing code, and the region, if any.

Subsections:

- [“Environment” on page 666](#)
- [“Syntax” on page 666](#)
- [“Equivalent IMS type-2 commands” on page 666](#)
- [“Output fields” on page 666](#)
- [“Examples” on page 666](#)

### Environment

The **/DISPLAY RTCODE** command is valid in DB/DC and DCCTL environments.

### Syntax

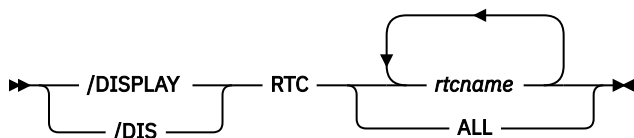

### Equivalent IMS type-2 commands

The following table shows variations of the **/DISPLAY RTC** command and the IMS type-2 commands that perform similar functions.

Table 305. Type-2 equivalents for the /DISPLAY RTC command

| Task  | /DISPLAY RTC command                             | Similar IMS type-2 command                                       |
|---|--|--|
| Displays information about one or more Fast Path routing codes. | /DISPLAY RTC <i>rtcname1...rtcnamen</i><br>  ALL | QUERY RTC<br>NAME( <i>rtcname1,...rtcnamen</i>   *)<br>SHOW(ALL) |

### Output fields

The status displayed can be one of the following:

```
NOTINIT
NOTSCHED
STOPPED
```

### Examples

Entry ET:

```
/DISPLAY RTCODE ALL
```

Response ET:

| RTCODE         | PROGRAM  | STATUS            |
|----------------|----------|-------------------|
| DCL            | EMHPSB   | NOTSCHED, STOPPED |
| EMHCOBOL       | EMHCOBOL | NOTSCHED, STOPPED |
| EMHPLI         | EMHPLI   | NOTSCHED, STOPPED |
| EMHTX          | EMHPSB   | NOTSCHED, STOPPED |
| TXCDLM06       | DDLTLMO6 | STOPPED           |
| TXCDLM07       | DDLTLMO7 | STOPPED           |
| *91068/114840* |          |                   |

### Related reference

[QUERY RTC command \(Commands\)](#)

## /DISPLAY SHUTDOWN STATUS command

Use the **/DISPLAY SHUTDOWN STATUS** command to display system activity during a shutdown type of checkpoint.

Subsections:

- [“Environment” on page 667](#)
- [“Syntax” on page 667](#)
- [“Usage notes” on page 667](#)
- [“Output fields” on page 668](#)
- [“Examples” on page 670](#)

### Environment

The following table lists the environments (DB/DC, DBCTL, and DCCTL) in which you can use the command and keywords.

Table 306. Valid environments for the /DISPLAY SHUTDOWN command and keywords

| Command / Keywords | DB/DC | DBCTL | DCCTL |
|--------------------|-------|-------|-------|
| <b>/DISPLAY</b>    | X     | X     | X     |
| SHUTDOWN           | X     | X     | X     |
| STATUS             | X     | X     | X     |

### Syntax

```

➔ /DISPLAY SHUTDOWN STATUS ➔
  /DIS

```

### Usage notes

When issuing the **/DISPLAY SHUTDOWN STATUS** command from a specific environment (such as DBCTL), only the information that is valid for that environment is displayed. For example, in a DBCTL environment, only the number of IMS threads is displayed.

In an LU 6.2 environment, the **/DISPLAY SHUTDOWN STATUS** command indicates the dependent regions that have active CPI Communications driven transaction programs. These regions must be terminated before shutdown is completed. In addition, the command also displays LU 6.2 conversations that hang the shutdown processing.

In a shared-queues environment, the **/DISPLAY SHUTDOWN STATUS** command displays the CQS job name that needs to be restarted if IMS shutdown hangs because CQS is inactive.

If a **/DISPLAY SHUTDOWN STATUS** command is issued while a database is being recovered with the Online Recovery Services, the response DB RECOVERY IN PROGRESS is returned in addition to the other responses. The **/DISPLAY SHUTDOWN STATUS** command displays a line with the count of active and indoubt ODBA threads that are active.

One of the following commands can be used to close the VTAM node:

- **/CHECKPOINT** (except simple checkpoint)
- **/CLSDST**
- **/IDLE NODE** (only after a **/CLDST** command has been tried first)
- **/QUIESCE** (for session type 6 nodes only)
- **/STOP NODE**

The **/STOP DC** command or the **/CHECKPOINT** (other than simple checkpoint) command can be issued to close the VTAM ACB.

If a checkpoint purge is in progress and messages are in the output queues, an orderly shutdown can be initiated by entering the **/CLSDST** command or the **/STOP** command. This allows termination after the next output message is sent, but might be insufficient for display terminals or terminals in input mode. If a node is hung, the following can be done:

1. A **/CLSDST FORCE** command can be issued.
2. If that fails, then the **/IDLE** command can be issued.

If any messages are queued for PTERM1 (system console) or the master terminal, they must be requested and received before the purge is completed. The **/STOP** and **/IDLE** commands are ineffective against these terminals. When using ISC parallel sessions, one line of information is displayed for each applicable session of the node. The user name is also displayed.

In addition to **/DISPLAY SHUTDOWN STATUS** command, use the following commands to get more information during shutdown:

- Use **/DISPLAY CTL** command for all coordinator controllers.
- Use **/DISPLAY UOR** command for displaying status information about units of work for protected resources that are managed by z/OS Resource Recovery Services (RRS).

## Output fields

The status displayed when the **/DISPLAY SHUTDOWN STATUS** command is issued can include the following information:

### **COMMIT x TMEMBER=membername TPIPE=tpipename**

The commit mode for the transaction and which OTMA client (member) and TPIPE is currently in progress and thus preventing completion of shutdown. COMMIT x can be either of the following:

- 0**  
Commit-Then-Send
- 1**  
Send-Then-Commit

### **Master Terminal Status**

The following text is displayed for the primary master, secondary master, or system console:

```
PRIMARY MSTR  
SECOND MSTR      ACTIVE , MESSAGES WAITING  
SYS CONSOLE
```

ACTIVE indicates the terminal is in the following states:



```
OPERABLE
ALLOWING INPUT
ALLOWING OUTPUT
NOT STOPPED FOR QUEUEING
NOT LOCKED
NOT IN TEST MODE
```

MESSAGES WAITING indicates that there are system messages (Q3) waiting to be sent, thus preventing shutdown from completing.

### **MSG-IN x MSG-OUT y**

The message totals, where *x* is the total number of input messages and *y* is the total number of output messages.

### **ONLINE CHANGE IN PROGRESS**

Online change was initiated with the **/MODIFY PREPARE** command or the **INITIATE OLC PHASE(PREPARE)** command.

### **OTMA PHASE=x**

The current phase of IMS Open Transaction Manager Access (OTMA) processing. The shutdown phases are:

- 1** OTMA shutdown processing has begun.
- 2** Dependent regions have terminated. For more information, see DFS1970.
- 3** OTMA is waiting for termination of all client-processing-related activities.
- 4** OTMA shutdown is complete.

### **SYSTEM PURGING**

The checkpoint is the result of a **/CHECKPOINT PURGE** command.

### **TERMINAL USER STATUS**

The header for the portion of the display output that shows active terminals, whose status can be one of the following:

```
INPUT IN PROCESS
OUTPUT IN PROCESS
AWAITING RESPONSE
XX MSGS IN QUEUE
```

If there is no terminal activity, the status can be one of the following:

```
NO INPUTTING LINES
NO OUTPUTTING LINES
```

If the system-defined MSC LNB is active, the following message is displayed:

```
LINK SYS      OUTPUT IN PROCESS
```

### **xx MSG PROCESSING REGION(S) ACTIVE**

Where *xx* is the number of BMP, TP, and FP regions that are active. If the checkpoint has already been posted, this is the only status displayed.

For DBCTL, a count of active CCTL threads is included.

### **xxx ODBA THREADS, yyy INDOUBT ODBA THREADS ACTIVE**

Where *xxx* is the number of active ODBA threads and *yyy* is number of indoubt ODBA threads active in the system

## xxxxxxx PROCESSING REGION(S) ACTIVE

Active regions, where xxxxxxxx is one of the following types:

```
BMP MSG
TP  MSG
FP
```

If status of a line or link shows input or output in progress and immediate shutdown is desired, the **/IDLE** command can be used.

### Examples

The following are examples of the **/DISPLAY SHUTDOWN STATUS** command.

#### **Example 1 for /DISPLAY SHUTDOWN STATUS command**

Entry ET:

```
/DISPLAY SHUTDOWN STATUS
```

Response ET:

```
DFS134 SHUTDOWN CHECKPOINT NOT IN PROGRESS,
CANNOT PROCESS COMMAND
```

Entry ET:

```
/DISPLAY SHUTDOWN STATUS
```

Response ET:

```
SYSTEM PURGING
TERMINAL  USER  STATUS
  5-   1      INPUT  IN PROCESS
  5-   2      INPUT  IN PROCESS
 11-   1      OUTPUT IN PROCESS
TERMINAL  USER  STATUS
LINK  10      OUTPUT IN PROCESS
MSG-IN   2      MSG-OUT  2
MASTER ACTIVE
*91111/222226*
```

Entry ET:

```
/DISPLAY SHUTDOWN STATUS
```

Response ET:

```
TERMINAL  USER  STATUS
NSLUTP6  SPOOLA  AWAITING RESPONSE
NSLUTP6  SPOOLB   5 MSGS IN QUEUE
NSLUTP6  SPOOLC  INPUT  IN PROCESS
NSLUTP6  SPOOLD  OUTPUT IN PROCESS
*91111/222226*
```

#### **Example 2 for /DISPLAY SHUTDOWN STATUS command**

Entry ET:

```
/DISPLAY SHUTDOWN STATUS
```

Response ET:

```

TERMINAL USER STATUS
 5- 1 INPUT IN PROCESS
 5- 2 INPUT IN PROCESS
11- 1 OUTPUT IN PROCESS
TERMINAL USER STATUS
LINK 10 OUTPUT IN PROCESS
MSG-IN 2 MSG-OUT 2
MASTER ACTIVE
CPI TRAN TRNCODE1 ACTIVE IN REGID 1
CPI TRAN TRNCODE2 ACTIVE IN REGID 4
IMSLU=L62IMS #APPC-CONV= 8 ENABLED
LUNAME STATUS
LUNAME1 3 CONVERSATIONS(S) IN PROCESS
LUNAME1 1 OUTPUT IN PROCESS
LUNAME2 4 CONVERSATIONS(S) IN PROCESS
*90332/114253*

```

Entry ET:

```
/DISPLAY SHUTDOWN STATUS
```

Response ET:

```

TERMINAL SUBPOOL STATUS
 5- 1 INPUT IN PROCESS
 5- 2 INPUT IN PROCESS
11- 1 OUTPUT IN PROCESS
TERMINAL SUBPOOL STATUS
LINK 10 OUTPUT IN PROCESS
MSG-IN 2 MSG-OUT 2
MASTER ACTIVE
CPI TRAN TRNCODE1 ACTIVE IN REGID1
CPI TRAN TRNCODE2 ACTIVE IN REGID4
IMSLU=SYS1.IMSLUNME #APPC-CONV= 8 ENABLED
LUNAME STATUS
NETWORK1.LUNAME1 3 CONVERSATION(S) IN PROCESS
NETWORK1.LUNAME1 1 OUTPUT IN PROCESS
NID2.LUNAME2 4 CONVERSATION(S) IN PROCESS
*92232/114253*

```

### **Example 3 for /DISPLAY SHUTDOWN STATUS command**

Entry ET:

```
/DISPLAY SHUTDOWN STATUS
```

Response ET:

```

TERMINAL USER STATUS
 1- 1 INPUT IN PROCESS
TERMINAL USER STATUS
NO OUTPUTTING LINES
MSG-IN 1 MSG-OUT 0
MASTER ACTIVE
OTMA PHASE=2
COMMIT 0 TMEMBER=CLIENT1 TPIPE=TPIPE1
*94298/174604*

```

### **Example 4 for /DISPLAY SHUTDOWN STATUS command**

Entry ET:

```
/DISPLAY SHUTDOWN STATUS
```

Response ET:

```

TERMINAL USER STATUS
 1- 1 INPUT IN PROCESS
TERMINAL USER STATUS
NO OUTPUTTING LINES
MSG-IN 1 MSG-OUT 0
PRIMARY MSTR SECOND MSTR ACTIVE, MESSAGES WAITING
IMSLU=N/A.N/A #APPC-CONV= 0 DISABLED
OTMA PHASE=0

```

```
0 ODBA THREADS,      1 INDOUBT ODBA THREADS ACTIVE
*06031/135629*
```

### Example 5 for /DISPLAY SHUTDOWN STATUS command

Entry ET:

```
/DISPLAY SHUTDOWN STATUS
```

Response ET:

```
TERMINAL  USER      STATUS
1- 1      INPUT IN PROCESS
TERMINAL  USER      STATUS
LINK SYS  OUTPUT IN PROCESS
MSG-IN 1  MSG-OUT 1
MASTER ACTIVE
IMSLU=L62IMS #APPC-CONV= 3 PURGING
LUNAME STATUS
IMSNET.L62MVS1 3 CONVERSATION(S) IN PROCESS
OTMA PHASE=0
*04292/112920*
```

### Related information

[DFS1970 \(Messages and Codes\)](#)

## /DISPLAY STATUS command

Use the **/DISPLAY STATUS** command to display the output for all the IMS resources.

Subsections:

- [“Environment” on page 672](#)
- [“Syntax” on page 673](#)
- [“Usage notes” on page 673](#)
- [“Equivalent IMS type-2 commands” on page 674](#)
- [“Output fields” on page 675](#)
- [“Examples” on page 675](#)

### Environment

The following table lists the environments (DB/DC, DBCTL, and DCCTL) in which you can use the command and keywords.

Table 307. Valid environments for the /DISPLAY STATUS command and keywords

| Command / Keywords | DB/DC | DBCTL | DCCTL |
|--------------------|-------|-------|-------|
| <b>/DISPLAY</b>    | X     | X     | X     |
| CLASS              | X     |       | X     |
| DATABASE           | X     | X     |       |
| LINE               | X     |       | X     |
| LINK               | X     |       | X     |
| LTERM              | X     |       | X     |
| LUNAME             | X     |       | X     |
| MSNAME             | X     |       | X     |

Table 307. Valid environments for the /DISPLAY STATUS command and keywords (continued)

| Command / Keywords | DB/DC | DBCTL | DCCTL |
|--------------------|-------|-------|-------|
| NODE               | X     |       | X     |
| PROGRAM            | X     | X     | X     |
| PTERM              | X     |       | X     |
| RTCODE             | X     |       | X     |
| STATUS             | X     | X     | X     |
| TMEMBER            | X     |       | X     |
| TRANSACTION        | X     |       | X     |
| USER               | X     |       | X     |

## Syntax

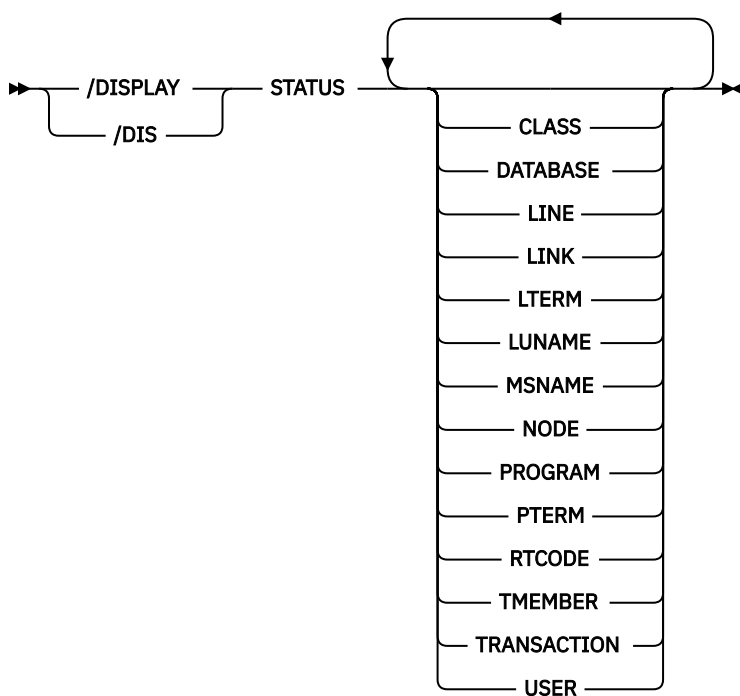

## Usage notes

Any combination of the indicated keywords can be used to display the associated resources. If no exceptional conditions are found for any of the resources specified by the individual keywords, STATUS UNRESTRICTED is displayed.

For Fast Path databases, the **/DISPLAY STATUS DATABASE** command shows the area and ADS exceptions as well as the database status. Each area with exceptions is displayed on a separate line after the database line. Each ADS with exceptions is displayed on a separate line after the area line.

The **/DISPLAY STATUS USER** command provides the status of a user. The ALLOC status is followed by the node name to which the user is allocated or signed onto in parenthesis.



**Attention:** In an IMSplex, if NODE, LTERM, or USER is specified with the **/DISPLAY STATUS** command, it will result in extensive accesses to the Resource Manager for global information, and their use should be carefully considered.

In a DBCTL environment, **/DISPLAY STATUS** displays only database and program information.

In a DCCTL environment, **/DISPLAY STATUS** does not display database information.

For **/DISPLAY STATUS TRANSACTION**, DFSCPIC is displayed as the PSB name for CPI Communications driven transactions that have not issued a DL/I APSB call to allocate a PSB.

A status of NOINIT will appear in the output of a **/DISPLAY STATUS TRANSACTION** command when IMS is unable to initialize a transaction resource during restart processing.

The **/DISPLAY STATUS LUNAME** command can indicate that a command such as **/STO LUNAME ALL INPUT** or **/STO LUNAME ALL OUTPUT** was entered before the **/DISPLAY** that applies to all future LU 6.2 inbound or outbound conversations.

The **/DISPLAY STATUS TMEMBER** command displays the IMS Open Transaction Manager Access (OTMA) transaction pipes that are stopped. If a transaction pipe is not stopped, its status is UNRESTRICTED. The command output includes information about stopped transaction pipes that are defined to super members and the super member name if a super member is used to manage the hold queue of a regular member.

## Equivalent IMS type-2 commands

The following table shows variations of the **/DISPLAY STATUS** command and the IMS type-2 commands that perform similar functions.

*Table 308. Type-2 equivalents for the /DISPLAY STATUS command*

| <b>Task</b>  | <b>/DISPLAY STATUS command</b>     | <b>Similar IMS type-2 command</b>   |
|--|------------------------------------|---|
| Displays information about databases with the specified status.                | <b>/DISPLAY STATUS DB</b>          | QUERY DB STATUS(ALLOCF, ALLOCS, BACKOUT, EEQE, LOCK, NOTINIT, NOTOPEN, OLR, OPEN, RECALL, RECOV, RNL, STOSCHD, STOUPDS) |
| Displays status.   | <b>/DISPLAY STATUS LTERM</b>       | QUERY LTERM SHOW(STATUS)  |
| Displays logical terminals with specified status.                              | <b>/DISPLAY STATUS LTERM</b>       | QUERY LTERM STATUS(status) SHOW(STATUS)   |
| Displays nodes with specified status.  | <b>/DISPLAY STATUS NODE</b>        | QUERY NODE STATUS(status)   |
| Displays all programs that have status and what that status is.                | <b>/DISPLAY STATUS PGM</b>         | QUERY PGM STATUS(DB-NOTAVL, IOPREV, LOCK, NOTINIT, STOSCHD, TRACE)  |
| Displays all Fast Path routing codes that have status and what that status is. | <b>/DISPLAY STATUS RTC</b>         | QUERY RTC STATUS(ACTIVE, NOTINIT, NOTSCHD, STOQ)  |
| Displays information about transactions with the specified status.             | <b>/DISPLAY STATUS TRANSACTION</b> | QUERY TRAN NAME( <i>trannname</i> ) STATUS (IOPREV, LCK, QERR, SUSPEND, STOQ, STOSCHD, USTO)                            |
| Displays users with specified status.  | <b>/DISPLAY STATUS USER</b>        | QUERY USER STATUS( <i>status</i> )  |

## Output fields

IMS resources that can be listed by the **/DISPLAY STATUS** command include resources in the states listed in the following table. The **/DISPLAY STATUS** command displays only conditions that require operator intervention.

Table 309. /DISPLAY STATUS resource states displayed

| Resource      | State  |
|---------------|--|
| CLASS         | STOPPED  |
| DATABASE      | ALLOCF, BACKOUT, EEQE, INQONLY, LOCK, NOTINIT, NOTOPEN   |
| DATABASE ADS  | PRE-OPEN FAILED, SEVERE-ERROR, UNAVAILABLE, COPY-PHASE, FORMAT-PHASE   |
| DATABASE AREA | RECOVERY NEEDED, STOPPED   |
| LINE          | IDLE, NOIN, NOOUT, NOQUEUE, NOTOPEN, PSTOPPED, PUR, RESP, RESP-INP, STOPPED  |
| LINK          | ACTV, COLD, ERE, IDLE, NOTIDLE-A, NOTIDLE-B, NOTIDLE-Cxx, NOTOPEN, NRE, N/A, PSTOPPED  |
| LTERM/MSNAME  | LOCK, PSTOPPED, PUR, QERROR, QLOCK, STOPPED  |
| LUNAME        | STO, STO-INP, STO-OUTP   |
| NODE          | CLSDST, CONV-HLD, C1INOP, C2INOP, C3INOP, C4INOP, DEACTIVATED, DISCONNECTED, FORCE, INOP, LOCK, LOST, OPNDST, QUIESCED, RESP, RESP-INP, RESP-INP-FP, RESYNC, SHUT, STOPPED |
| PROGRAM       | DB-STOPD, I/O PREVENT, LOCK, NOTINIT, STOPPED  |
| PTERM         | COMPINOP, CONV-HLD, EXCL, INOP, LOCK, LOOPTEST, NOIN, NOTOPEN, NOOUT, NOQUEUE, PSTOPPED, PUR, RESP, RESP-INP, STOPPED, TEST  |
| RTCODE        | NOTINIT, STOPPED   |
| TMEMBER       | STO  |
| TRAN          | LOCK, NOTINIT, PSTOPPED, PUR, QERROR, QSTP, SPND, STOPPED, USTOPPED  |
| USER          | CONV-HLD, DEADQ, RESP, RESP-INP, RESP-INP-FP, STOPPED  |

## Examples

The following are examples of the **/DISPLAY STATUS** command.

### Example 1 for /DISPLAY STATUS command

Entry ET:

```
/DISPLAY STATUS
```

Response ET:

```
**TRAN****PSBNAME
STATUS UNRESTRICTED
**DATABASE**
BMACC1      NOTOPEN,NOTINIT,STOPPED
DEDB01
```

```

-AREA01      RECOVERY-NEEDED
DEDEB03
-AREA02
  ADS01      PRE-OPEN FAILED
DEDB04      NOTOPEN, STOPPED
-AREA01      RECOVERY-NEEDED
  ADS01      UNAVAILABLE
**PROGRAM***
HIMASN01    STOPPED
SWITCH      STOPPED
**NODE****
CT3275      DISCONNECTED
CT3277A     DISCONNECTED
CT3277B     SHUT
W612        DISCONNECTED
**LINE*****
4           STOPPED, IDLE
5           STOPPED, IDLE, NOTOPEN
8           STOPPED, IDLE
10          STOPPED, IDLE, NOTOPEN
**PTERM*****
3           1 INOP, STOPPED
3           2 INOP, STOPPED
4           2 INOP, PSTOPPED
5           1 INOP, STOPPED
5           2 INOP, STOPPED
6           1 INOP, STOPPED
**LTERM*****
LU6A        STOPPED
VA01        QLOCK
**CLASS*****
2           STOPPED
**RTCODE****
STATUS UNRESTRICTED
**LINK*****
1           PSTOPPED, IDLE, NOTOPEN
3           PSTOPPED, IDLE, COLD
4           PSTOPPED, IDLE, N/A
5           PSTOPPED, IDLE, NOTOPEN
**MSNAME****
STATUS UNRESTRICTED
**USER*****
STATUS UNRESTRICTED
**LUNAME**TPNAME****
STATUS UNRESTRICTED
*92198/132223*

```

### **Example 2 for /DISPLAY STATUS command**

Entry ET:

```
/DISPLAY STATUS DATABASE
```

Response ET:

```

**DATABASE**
DEDB01
-AREA01      STOPPED
DEDB02
-AREA02      NOTOPEN
-AREA03
  ADS03      PRE-OPEN FAILED
DEDB03
-AREA05      STOPPED, NOTOPEN
  ADS03      PRE-OPEN FAILED
  ADS08      UNAVAILABLE
DEDB04      STOPPED
DEDB05      NOTOPEN, NOTINIT
-AREA01      STOPPED
-AREA08      STOPPED, NOTOPEN
DEDB06      STOPPED
-AREA03
  ADS03      UNAVAILABLE
DEDB0777    NOTOPEN, LOCK
-AREA0555   STOPPED, NOTOPEN
  ADS03333  SEVERE ERROR
  ADS08888  UNAVAILABLE
*90263/092128*

```



### Example 3 for /DISPLAY STATUS command

Entry ET:

```
/DISPLAY STATUS LUNAME
```

Response ET:

```
**LUNAME/TPNAME**  
LU2  
-TPN2          STO  
LU5  
-TPNAME1234567890+ STO  
 1234567890  
LU3          STO-INP  
LU4          STO-OUTP  
LU1          STO-INP, STO-OUTP  
*95229/155100*
```

Entry ET:

```
/DISPLAY STATUS LUNAME
```

Response ET:

```
**LUNAME/TPNAME**  
LU2          STO-INP, STO-OUTP  
-TPN2          STO  
LU5          STO-INP, STO-OUTP  
-TPN5          STO  
-TPNAME1234567890+ STO  
 1234567890  
LU3          STO-INP, STO-OUTP  
LU4          STO-INP, STO-OUTP  
LU1          STO-INP, STO-OUTP  
FUTURE INPUT: STO  
FUTURE OUTPUT: STO  
*95229/155146*
```

### Example 4 for /DISPLAY STATUS command

Entry ET:

```
/DISPLAY STATUS NODE
```

Response ET:

```
**NODE*****  
NLUTP6S     DISCONNECTED  
NLU1        STOPPED, DISCONNECTED  
NLUTP6P  
-A          HELD  
-N/A        STOPPED, DISCONNECTED  
-E          FORCE  
-C  
*90231/040059*
```

Entry ET:

```
/DISPLAY STATUS RTCODE
```

Response ET:

```
**RTCODE****  
DCL         STOPPED  
EMHCOB0L   STOPPED  
EMHPLI     STOPPED  
EMHTX      STOPPED  
TXCDBP04   STOPPED  
TXCDBP05   STOPPED  
TXCDBP06   STOPPED  
*91068/114900*
```

### Example 5 for /DISPLAY STATUS command

Entry ET:

```
/DISPLAY STATUS TMEMBER
```

Response ET:

```
**TMEMBER/TPIPE**  
CLIENT1  
-TPIPE1          STO  
*94168/095431*
```

### Example 6 for /DISPLAY STATUS command

Entry ET:

```
/DISPLAY STATUS TRANSACTION
```

Response ET:

```
**TRAN****PSBNAME  
TPN4      DFSCPIC  PUR  
TPN5      DFSCPIC  STOPPED  
TPN6      DFSCPIC  I/O PREVEN  
TPN7      DFSCPIC  USTOPPED  
TRAN1     LU2PGM1  PSTOPPED  
TRAN2     LU2PGM2  PSTOPPED  
*90332/114253*
```

### Example 7 for /DISPLAY STATUS command

Entry ET:

```
/DISPLAY STATUS TMEMBER
```

Response ET:

```
**TMEMBER/TPIPE**  
HWS001          SM01  
-TPIPE1          STO  
-TPIPE3          STO  
SM01            SM01  
-TPIPE1          STO  
-TPIPE2          STO  
-TPIPE3          STO  
HWS003  
-TPIPE1          STO  
*05049/095431*
```

### Example 8 for /DISPLAY STATUS command

Entry ET:

```
/DISPLAY STATUS CLASS
```

Response ET:

```
R 24,/DISPLAY STATUS CLASS  
IEE600I REPLY TO 24 IS;/DISPLAY STATUS CLASS  
DFS000I      **CLASS****      IMS1  
DFS000I      255      STOPPED  IMS1  
DFS000I      *15306/163251*  IMS1  
25 DFS996I *IMS READY*  IMS1
```

Explanation: HWS001 is a regular member whose hold queue output is managed by super member SM01. HWS001 has two transaction pipes that are stopped. SM01 is a super member with three transaction pipes that are stopped. HWS003 also has a stopped transaction pipe. HWS003 is a regular member that manages its own hold queue output.

## Related reference

[“Status and attributes for the /DISPLAY command” on page 501](#)

A list of the attributes and status shown in the **/DISPLAY** command are described in the following table.

[QUERY DB command \(Commands\)](#)

[QUERY LTERM command \(Commands\)](#)

[QUERY NODE command \(Commands\)](#)

[QUERY PGM command \(Commands\)](#)

[QUERY RTC command \(Commands\)](#)

[QUERY TRAN command \(Commands\)](#)

[QUERY USER command \(Commands\)](#)

## **/DISPLAY STRUCTURE** command

---

Use the **/DISPLAY STRUCTURE** command to display the status of one or more coupling facility list queue structures used by IMS. This command displays the queue structure name, type, and status.

Subsections:

- [“Environment” on page 679](#)
- [“Syntax” on page 679](#)
- [“Usage notes” on page 679](#)
- [“Output fields” on page 679](#)
- [“Examples” on page 680](#)

### Environment

The **/DISPLAY STRUCTURE** command is valid in DB/DC and DCCTL environments.

### Syntax

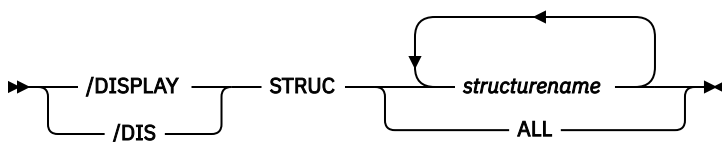

### Usage notes

This command is valid only in a shared-queues environment.

### Output fields

The following output fields are displayed for the **/DISPLAY STRUCTURE** command:

#### STATUS

The status conditions that can be displayed. Possible status values are:

##### AVAILABLE

The structure is available to be used by IMS.

##### CONNECTED

IMS is connected to the structure.

##### DISCONNECTED

IMS is not connected to the structure.

**IN-OVERFLOW**

The structure is in overflow mode.

**REBLD-INPROG**

A rebuild is in progress for the structure.

**SHUTDOWN-STRCHKPT**

A structure checkpoint will be taken by CQS for the structure during a CQS normal shutdown.

**STRCHKPT-INPROG**

A structure checkpoint is in progress for the structure.

**UNAVAILABLE**

The structure is not available to be used by IMS.

**STRUCTURE NAME**

Indicates the name of the list structure.

**TYPE**

Returns the list structure type, which can be either of the following:

**MSGQ**

Indicates a MSGQ primary or overflow structure.

**EMHQ**

Indicates an EMHQ primary or overflow structure.

**Examples**

Entry ET:

```
/DISPLAY STRUCTURE ALL
```

Response ET:

| STRUCTURE NAME | TYPE | STATUS                                  |
|----------------|------|---|
| MSGQ1          | MSGQ | CONNECTED, AVAILABLE, SHUTDOWN-STRCHKPT |
| EMHQ1          | EMHQ | CONNECTED, AVAILABLE, IN-OVERFLOW       |
| *95200/170817* |      |   |

Entry ET:

```
/DISPLAY STRUCTURE MSGQ111 EMHQ1
```

Response ET:

| STRUCTURE NAME | TYPE | STATUS       |
|----------------|------|--------------|
| MSGQ111        |      | IS INVALID   |
| EMHQ1          | EMHQ | DISCONNECTED |
| *95201/121800  |      |              |

## **/DISPLAY SUBSYS command**

Use the **/DISPLAY SUBSYS** command to display information about an external subsystem that is not a coordinator controller (CCTL) subsystem. ESS TYPE and RLA are now displayed on the second line of the **/DIS SUBSYS** command output.

Subsections:

- [“Environment” on page 681](#)
- [“Syntax” on page 681](#)
- [“Usage notes” on page 681](#)
- [“Output fields” on page 681](#)

- [“Examples” on page 682](#)

## Environment

The **/DISPLAY SUBSYS** command is valid in DB/DC, DBCTL, and DCCTL environments.

## Syntax

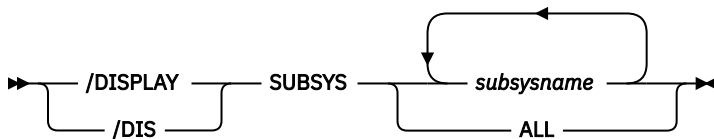

## Usage notes

When used without the OASN keyword, the SUBSYS keyword displays the status of the connection between IMS and the external subsystem (not CCTL), as well as all application programs communicating with the external subsystem (not CCTL). The OASN keyword is used with the SUBSYS keyword to display all OASNs associated with the specified external subsystem. The external subsystem is not a CCTL subsystem. See [“/DISPLAY OASN SUBSYS command” on page 616](#) for more information.

The **RLA=** parameter is displayed based on SSM= proclib member in IMS control region.

## Output fields

Subsystem status terms can be generated by the **/DISPLAY SUBSYS** command. Dependent region status terms can be generated by the **/DISPLAY SUBSYS** or **/DISPLAY ACTIVE** command.

### Subsystem status terms

#### CONN

The IMS control region has successfully completed a host system IDENTIFY request to the external subsystem, making the two subsystems aware of each other's existence so they can begin a normal dialog.

#### NOT CONN

The external subsystem is in an idle state; that is, the external subsystem has not been the object of the **/STOP SUBSYS** command, or the external subsystem initialization exit indicated not to issue the IDENTIFY REQUEST (connect)

#### CONN IN PROGRESS

The connection process for the specified subsystem is in progress

#### STOPPED

The specified subsystem has been successfully stopped using the **/STOP SUBSYS** command and all region connections to the specified external subsystem have been terminated

#### STOP IN PROGRESS

The **/STOP SUBSYS** command is in progress. Before it successfully completes, all active connections to the specified subsystem from all IMS regions must be quiesced.

#### TERM IN PROGRESS

An internal termination of the subsystem connection is underway. This type of termination might be instigated by one of the following conditions:

- The external subsystem termination service exit was called to initiate subsystem disconnect processing.
- IMS drives the external subsystem termination in a quiesce fashion.

- IMS drives the external subsystem termination in a quick or catastrophic fashion.

A X'5609' log record for subsystem disconnect is created for the termination, which indicates the type of external subsystem termination that is in progress.

An IMS shutdown does not result in this condition.

#### **INVALID SUBSYSTEM NAME = XXXX**

The specified subsystem name has not been defined in the IMS subsystem PROCLIB member

#### **SUBSYSTEM XXXX NOT DEFINED BUT RECOVERY OUTSTANDING**

The specified subsystem name has not been defined to IMS in the external subsystem PROCLIB member, but IMS still has outstanding recovery elements from a previous execution when the indicated subsystem was known

The command recognition character will also be displayed for the external subsystem.

#### **START-AF**

The specified subsystem that is attached by the DB2 z/OS Resource Recovery Services (RRS) attachment facility has been successfully started by using the **/START** command, and dependent region connections to this system will be permitted.

#### **STOP-AF**

The specified subsystem which was attached by the DB2 z/OS Resource Recovery Services (RRS) attachment facility has been successfully stopped by using the **/STOP** command, and no more dependent region connections to this system will be permitted.

#### ***Dependent region status terms***

##### **CONN**

An IMS dependent region has successfully completed a host system IDENTIFY request to the external subsystem as a result of an application having been scheduled into the dependent region. In an MPP, the application does not have to issue an external subsystem call to cause a connection.

##### **CONN, ACTIVE**

An IMS application program has established communication with an external subsystem (for example, has issued at least one external subsystem call). At this point a thread exists between the IMS application program and the external subsystem.

The absence of a PSB name for a thread indicates that a connection to the external subsystem exists but an application program is not currently occupying the region. The presence or absence of an LTERM name indicates whether a region is message driven.

LTERM is the name of the terminal. LUNAME is displayed in place of LTERM when the originating terminal is LU6.2 or OTMA unless the LUNAME information is in transition, in which case, the literal UNKNOWN will be displayed.

#### **Examples**

The following are examples of the **/DISPLAY SUBSYS** command.

##### ***Example 1 for /DISPLAY SUBSYS command***

The external subsystem that is being displayed, V10A, is a DB2 subsystem. It has the command recognition character "@" and is currently active.

Entry ET:

```
/DISPLAY SUBSYS ALL
```

Response ET:

```
      SUBSYS   CRC REGID PROGRAM  LTERM
STATUS
```

```

ESSTYPE  RLA
V10A     @
CONN
DB2      Y
          1      DSN8IC0  FPE0001  CONN, ACTIVE
          2      DSN8IC2  FPE0002  CONN, ACTIVE
          3      DSN8IC3  FPE0003  CONN,
V10B     -
DB2
ACTIVE
*13242/145525*  SYS3

```

**Example 2 for /DISPLAY SUBSYS command**

The external subsystem that is being displayed, V10A, is a DB2 subsystem. It has the command recognition character "@" and is currently stopped.

TSO SPOC input:

```
DIS SUBSYS ALL
```

TSO SPOC output:

```

IMSpIex . . . . . : PLEX1
Routing . . . . . : SYS3
Start time . . . . : 2013.256 16:01:17.63
Stop time . . . . . : 2013.256 16:01:17.66
Return code . . . . : 00000000
Reason code . . . . : 00000000
Reason text . . . . :
Command master. . . : SYS3

MbrName  Messages
-----
SYS3     SUBSYS   CRC REGID PROGRAM  LTERM  STATUS
SYS3     ESSTYPE  RLA
SYS3     V10A     @
SYS3     DB2      Y
SYS3     *13256/160117*

```

## **/DISPLAY SYSID TRANSACTION command**

Use the **/DISPLAY SYSID TRANSACTION** command to display the IDs of the local and remote systems associated with the transaction. Values displayed for the local and remote IDs can range from 1 to 2036.

Subsections:

- [“Environment” on page 683](#)
- [“Syntax” on page 684](#)
- [“Examples” on page 684](#)

### **Environment**

The following table lists the environments (DB/DC, DBCTL, and DCCTL) in which you can use the command and keywords.

*Table 310. Valid environments for the /DISPLAY SYSID TRANSACTION command and keywords*

| <b>Command / Keywords</b> | <b>DB/DC</b> | <b>DBCTL</b> | <b>DCCTL</b> |
|---------------------------|--------------|--------------|--------------|
| <b>/DISPLAY</b>           | X            | X            | X            |
| SYSID                     | X            |              | X            |
| TRANSACTION               | X            |              | X            |

## Syntax



## Examples

Entry ET:

```
/DISPLAY SYSID TRANSACTION SKS1 SKS2 SKS3 SKS4
```

Response ET:

| TRAN | PSBNAME | RID | LID |
|------|---------|-----|-----|
| SKS1 | DFSDDL1 | 21  | 11  |
| SKS2 | DFSDDL2 | NA  | 11  |
| SKS3 | DFSDDL3 | NA  | 11  |
| SKS4 | DFSDDL4 | 32  | 12  |

\*89184/142436\*

## /DISPLAY TIMEOVER command

Use the **/DISPLAY TIMEOVER** command to display all nodes that have been waiting for a response for a longer time than specified in the **/TRACE SET ON TIMEOUT** command.

Subsections:

- [“Environment” on page 684](#)
- [“Syntax” on page 684](#)
- [“Usage notes” on page 685](#)
- [“Examples” on page 685](#)

## Environment

The **/DISPLAY TIMEOVER** command is valid in DB/DC and DCCTL environments.

## Syntax

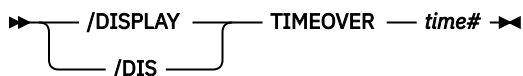

## Keywords

The following keywords can be specified for the **/DISPLAY TIMEOVER** command:

### **time#**

Specifies the time period in minutes. This parameter is required. The number of minutes must be between 1 and 60.



## Usage notes

If no nodes are found that have been waiting longer than *time#* minutes, then the message NO NODE WITH TIMEOVER *time#* FOUND is displayed. An error message is displayed and the command is rejected if the timeout trace facility failed during IMS initialization. User names are displayed for ISC nodes, but non-ISC nodes show N/A.

## Examples

Entry ET:

```
/DISPLAY TIMEOVER 10
```

Response ET:

| NODE           | USER   | TYPE | LAST OUTPUT  | START TIME |
|----------------|--------|------|--------------|------------|
| SLU1A          | N/A    | SLU1 | 88118/095914 |            |
| LU6NDPC        | LU6SPC | LUT6 | 88118/095921 |            |
| SLU1C          | N/A    | SLU1 | 88118/095929 |            |
| SLU1B          | N/A    | SLU1 | 88118/095937 |            |
| SLU1D          | N/A    | SLU1 | 88118/095943 |            |
| LU6NDPA        | LU6SPA | LUT6 | 88118/095949 |            |
| *88118/101150* |        |      |              |            |

## Example for ISC TCP/IP terminals

Entry ET:

```
/DISPLAY TIMEOVER 10
```

Response ET:

| NODE           | USER    | LINK# | TYPE | LAST OUTPUT  | START TIME |
|----------------|---------|-------|------|--------------|------------|
| CICS           | IMSUS01 | N/A   | TCP  | 12088/171914 |            |
| *12088/101948* |         |       |      |              |            |

## **/DISPLAY TMEMBER** command

Use the **/DISPLAY TMEMBER** command to display the current target member status for IMS Open Transaction Manager Access (OTMA) clients and servers.

Subsections:

- [“Environment” on page 685](#)
- [“Syntax” on page 686](#)
- [“Keywords” on page 686](#)
- [“Usage notes” on page 687](#)
- [“Output fields” on page 688](#)
- [“Examples” on page 691](#)

## Environment

The following table lists the environments (DB/DC, DBCTL, and DCCTL) in which you can use the command and keywords.

Table 311. Valid environments for the /DISPLAY TMEMBER command and keywords

| Command / Keywords | DB/DC | DBCTL | DCCTL |
|--------------------|-------|-------|-------|
| /DISPLAY           | X     | X     | X     |
| QCNT               | X     |       | X     |
| TMEMBER            | X     |       | X     |
| TPIPE              | X     |       | X     |

## Syntax

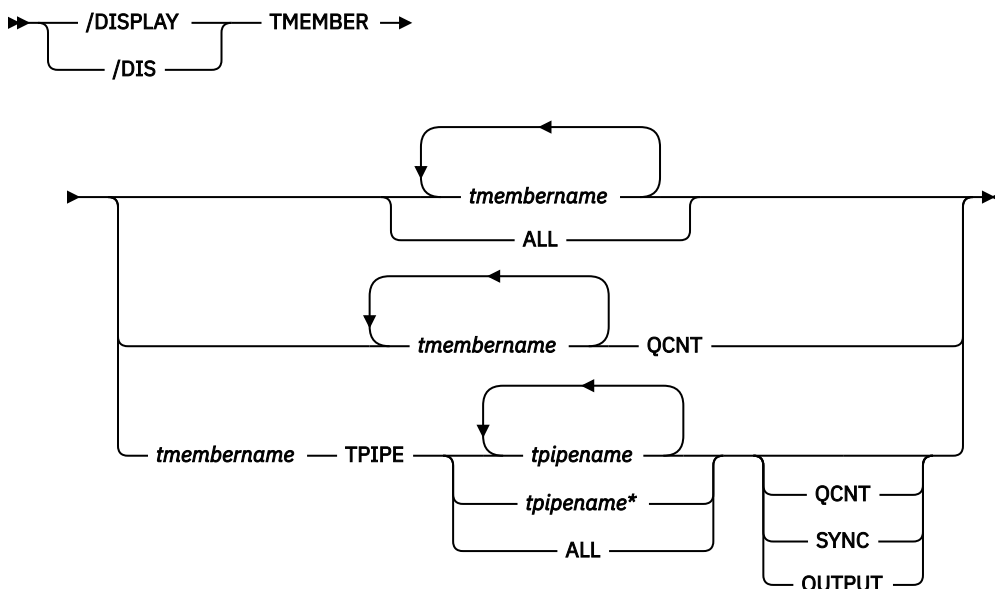

## Keywords

The following keywords can be specified for the **/DISPLAY TMEMBER** command.

### QCNT

The **/DISPLAY TMEMBER** command with the QCNT parameter specifies that global queue count information is to be displayed. If the member specified is a super member, global queue count information is displayed for the super member. If the member specified is a regular member whose hold queue output is managed by a super member, the name of the super member is displayed along with the global queue count information for the regular member.

This count represents the message counts of messages that can be processed by the IMS system where the command is issued. This count includes messages that can be processed by any IMS system (messages with no affinity), plus messages that can be processed by the IMS system where the command is issued (messages with an affinity to the IMS system that issued the command).

The **/DISPLAY TMEMBER QCNT** form of the command is valid only in a shared-queues environment.

### TPIPE

The **/DISPLAY TMEMBER TPIPE** command can be issued to display transaction pipe status for a member. If the member specified is a super member, transaction pipe status is displayed for the super member. If the member specified is a regular member whose hold queue output is managed by a super member, the name of the super member is displayed along with the queue count information.

The tpipe name can be ended with a generic character (\*). This generic form of tpipe name can also be used with QCNT or SYNC keywords. The tpipe name with a generic character cannot be mixed with other tpipe names. The valid formats for using a tpipe name with the generic character are:

```
/DIS TMEMBER membername TPIPE tpipename*  
/DIS TMEMBER membername TPIPE tpipename* QCNT  
/DIS TMEMBER membername TPIPE tpipename* SYNC
```

### QCNT

The **/DISPLAY TMEMBER TPIPE** command with the QCNT parameter specifies that global queue count information is to be displayed. If the member specified is a super member, global queue count information is displayed for the transaction pipes associated with the super member. If the member specified is a regular member whose hold queue output is managed by a super member, the name of the super member is displayed along with the global queue count information.

The **/DISPLAY TMEMBER TPIPE QCNT** form of the command is valid only in a shared-queues environment.

### SYNC

The **/DISPLAY TMEMBER TPIPE SYNC** command displays:

- The number of active synchronous callout messages
- The number of synchronous callout messages waiting for response
- The number of resume tpipe requests that are currently active on the TPIPE
- The resume tpipe option
- The resume tpipe mode
- The tpipe status

The **/DISPLAY TMEMBER TPIPE SYNC** command can be considered as a superset of the **/DISPLAY TMEMBER TPIPE** command.

### OUTPUT

The **/DISPLAY TMEMBER TPIPE OUTPUT** command can be used to display the output counts for both primary and holdq queues when the OTMA client is holdq-capable (for example, IMS Connect). This parameter is ignored for clients that are not holdq-capable (such as IBM MQ) and when IMS has shared queues enabled.

When support for multiple active resume tpipe requests is enabled (MULTIRTP=Y), the output includes the unique identifier, the resume tpipe option, and the mode for each resume tpipe request that is active on a tpipe.

**Important:** Specifying the OUTPUT parameter can double the number of lines for the display. Take care when using the ALL or masked TPIPE names for TMEMBERs with a large number of TPIPEs.

If support for multiple active resume tpipe requests is enabled (MULTIRTP=Y), the output can include even more lines if there are many active resume tpipe requests on the tpipes.

The OUTPUT parameter is mutually exclusive with the SYNC and QCNT parameters.

## Usage notes

The **/DISPLAY TMEMBER** command includes five variations: **/DISPLAY TMEMBER QCNT**, **/DISPLAY TMEMBER TPIPE**, **/DISPLAY TMEMBER TPIPE QCNT**, **/DISPLAY TMEMBER TPIPE SYNC** and **/DISPLAY TMEMBER TPIPE OUTPUT**.

In a shared-queues environment, use the QCNT keyword to obtain the current message queue counts on the shared queues structure. The local queue counts (ENQCT, DEQCT, and QCT) value that is returned on this command when the QCNT keyword is not specified represents the messages being processed by the IMS system where this command is issued. Do not use local queue counts for queue evaluation purposes.

## Output fields

The following output fields are displayed for the **/DISPLAY TMEMBER** command:

### DEQCT

Total number of messages that are dequeued from the OTMA tpipe for this member. If the OTMA hold queue is used for a client that is capable of the OTMA hold queue, such as IMS Connect, the number of the messages in the hold queue of this tpipe is also included. In a shared-queues environment, this field shows only the messages dequeued for the local subsystem.

### DRUEXIT

The name of any OTMA Destination Resolution exit routine associated with the tmember.

### ENQCT

Total number of messages that are enqueued on the OTMA tpipe for this member. If the OTMA hold queue is used for a client that is capable of the OTMA hold queue, such as IMS Connect, the number of the messages in the hold queue of this tpipe is also included. In a shared-queues environment, this field shows only the messages enqueued for the local subsystem.

### GROUP/MEMBER

Each member in each z/OS cross-system coupling facility (XCF) group.

When you issue **/DISPLAY TMEMBER ALL**, the server is always the first member displayed.

### INPT

The maximum concurrent input message count for this member that can be waiting at the same time to be processed. If the YTIBs reach the INPT value, an OTMA FLOOD condition exists and the subsequent input messages from the member will be rejected.

### MAXTP

The maximum TPIPE limit that is specified in the OTMA client descriptor. If the MAXTP parameter is specified for DFSOTMA in the OTMA client descriptor, the MAXTP limit is displayed for the OTMA server. If there are one or more OTMA clients with the MAXTP limit defined and MAXTP is not specified for DFSOTMA, the highest limit defined among the members is displayed for the OTMA server.

### MODE

The resume tpipe mode, which can be one of the following:

- S - Synchronous callout messages
- B - Both asynchronous messages and synchronous callout messages
- A - Asynchronous messages

### NO-COT

The current number of ICAL messages received for this tpipe. If the number is greater than or equal to 65535, it will be reset to 1.

### OPT

The resume tpipe option, which can be one of the following:

- N - No auto flow of messages. When a client issues a resume tpipe call and no message is present, the resume tpipe call ends.
- S - Single message. When a client issues a resume tpipe call, if multiple messages are present, only one message is retrieved. If no message is present, the call ends.
- A - Auto flow of messages. The client retrieves one message at a time. If no messages exist in the tpipe, the client waits for subsequent messages from the hold queue.
- W - Single message with wait option. The client will retrieve only one message. If there are no messages in the hold queue, the client will wait until a message arrives, then the call ends. Only one message is retrieved regardless of how many messages are in the hold queue.

This option is specified in the IRM\_F5 field of the IRM prefix in the messages that are sent to IMS Connect.

**QCT**

Total number of messages that are still in the queue for OTMA tpipe for this member. If the OTMA hold queue is used for a client that is capable of the OTMA hold queue, such as IMS Connect, the number of the messages in the hold queue of this tpipe is also included. In a shared-queues environment, this field shows only the messages enqueued for the local subsystem.

**RTA**

The number of active Resume TPIPE requests. This field is displayed only when the SYNC keyword is specified on the command.

**RTQ**

The number of queued resume tpipe requests to be processed. This field is displayed only for the command issued with the SYNC keyword.

**SECURITY**

The security status for each member or server

The security status can be one of the following:

- NONE
- JOIN
- CHECK
- FULL
- PROFILE

**SYNCOT**

The number of active synchronous callout messages.

**TIB**

The number of current input messages processed by OTMA for this member. This number will be incremented when a new transaction is received, and it will be decremented after OTMA enqueues a CM0 input transaction or OTMA completes a CM1 transaction. There are cases where orphaned transaction instance blocks (YTIBs) are created. These YTIBs will not be deleted until IMS is cold started.

**TPCNT**

The TPIPE count for the OTMA client or for the IMS server.

For an OTMA client, this field indicates the current TPIPE count for that member. For the IMS server, this field indicates the current global TPIPE count for the IMS server. This count value is limited to display at most 99999. When 99999 is displayed, it indicates the TPIPE count is 99999 or higher.

**T/O**

The timeout value for OTMA send-then-commit message responses.

**USER-STATUS**

The user status for each member.

The status can be one of the following:

- ACCEPT TRAFFIC
- DISCONNECTED
- IN SLOWDOWN
- MAX TPIPE: MAX TPIPE indicates that the OTMA member's TPIPE count has reached the limit set. This status is cleared when the global TPIPE count falls below 50%.
- SERVER
- SUPER MEMBER
- WAIT BID
- WAIT RESPONSE

If the member specified is a regular member whose member name is displayed as part of the command output. If the member specified is a super member, the character string 'SUPER MEMBER'

is displayed for the user status. Since a super member does not interface with XCF, the XCF-STATUS field is left blank. Since super members do not process input messages, OTMA security authorization is not performed.

### **XCF-STATUS**

The XCF status for each member.

The status can be one of the following:

- ACTIVE
- CREATED
- FAILED
- FLOOD
- NOT DEFINED
- QUIESCED
- STO-INPUT
- UNKNOWN

If the server leaves the XCF group (for example, because of a **/STOP OTMA** command), then the XCF status is displayed as NOT DEFINED.

The output from the **/DISPLAY TMEMBER QCNT** or **/DISPLAY TMEMBER TPIPE QCNT** command includes the following:

### **AFFINITY**

The IMSID (or the first 7 bytes of the RSENAME, if XRF capable) of the IMS to which the output messages have affinity.

### **GBLQCT**

The total number of OTMA output messages on the global queue. The global queue count includes messages that were placed on the global queue before the latest cold start of the owning IMS. Synchronous and asynchronous OTMA output messages are included in the global queue count. Messages on an OTMA asynchronous hold queue for IMS Connect are also included in the global queue count.

### **MEMBER/TPIPE**

OTMA member name. If the TPIPE keyword is specified, the transaction pipe name is also displayed. The first line displays the OTMA member name. The second and subsequent lines display the names of the transaction pipes associated with the OTMA member.

One of the following status terms is displayed for the **/DISPLAY TMEMBER** command specified with the TPIPE keyword:

### **DQF**

Dequeue request for OTMA **REPresynch** command failed.

### **FLOOD**

Input from this tmember is suppressed because of a message flood condition.

### **HLDQ**

Queue counts for the holdq queue.

### **INPCT**

The current number of input messages received for this tpipe.

### **MCP**

In a shared-queues environment, the transaction pipe has output messages on the global queue.

### **PMRY**

Queue counts for the primary queue.

### **REP**

IMS is waiting for an OTMA **REPresynch** command from the client.

**REQ**

IMS is sending an OTMA **REQresynch** command to the client.

**RSF**

Reset request failed for an OTMA **REPresynch** command.

**STO**

The transaction pipe is stopped.

**STO-INPUT**

Input from this tmember is stopped.

**SYN**

The transaction pipe is being synchronized.

**TBR**

IMS is waiting for an OTMA **TBRresynch** command from the client.

**TMP**

The transaction pipe is temporary.

**TRA**

The transaction pipe is being traced.

**WAIT\_A**

The transaction pipe is waiting for an ACK or NAK for a commit-then-send (CM0) output response.

**WAIT\_H**

The transaction pipe is waiting for an ACK or NAK for a commit-then-send (CM0) output response from the asynchronous hold queue.

**WAIT\_R**

The transaction pipe is waiting for an ACK or NAK response to a commit-then-send (CM0) output message that was sent to a remote IMS system through a TCP/IP connection managed by IMS Connect.

**WAIT\_S**

The transaction pipe is waiting for an ACK or NAK for a synchronous callout message.

**Examples**

The following are examples of the **/DISPLAY TMEMBER** command.

**Example 1 for /DISPLAY TMEMBER command**

Entry ET:

```
/DISPLAY TMEMBER ALL
```

Response ET:

| GROUP/MEMBER | XCF-STATUS<br>DRUEXIT | USER-STATUS<br>T/O | SECURITY | TIB | INPT | SMEM |
|--------------|-----------------------|--------------------|----------|-----|------|------|
| HARRY        |                       |                    |          |     |      |      |
| IMS1         | ACTIVE                | SERVER             | FULL     |     |      |      |
| HWS001       | ACTIVE                | ACCEPT TRAFFIC     | FULL     | 0   | 0    | SM01 |
| HWS001       | HWSYDRU0              | 5                  |          |     |      |      |
| SM01         |                       | SUPER MEMBER       |          |     |      | SM01 |
| MQS001       | ACTIVE                | ACCEPT TRAFFIC     | FULL     | 0   | 0    |      |
| MQS001       | MQSYDRU0              | 10                 |          |     |      |      |

Explanation: The **/DISPLAY TMEMBER ALL** command can be issued to display the current status of IMS server and members. This command is functionally equivalent to the **/DIS OTMA** command. The member information is displayed in random order. In the above example, HARRY is the XCF group name for IMS and its OTMA members. IMS1 is the server running with OTMA activated. HWS001 and MQS001 are OTMA client members. The SM01 is an OTMA super member for asynchronous output messages. Each OTMA member has two-line status information

**Example 2 for /DISPLAY TMEMBER command**

Entry ET:

```
/DISPLAY TMEMBER MQS001
```

Response ET:

| GROUP/MEMBER | XCF-STATUS | USER-STATUS    | SECURITY | TIB | INPT | SMEM |
|--------------|------------|----------------|----------|-----|------|------|
|              | DRUEXIT    | T/O            |          |     |      |      |
| MQS001       | ACTIVE     | ACCEPT TRAFFIC | FULL     | 0   | 0    |      |
| MQS001       | MQSYDRU0   | 10             |          |     |      |      |

**Explanation:** In the above example, MQS001 is an OTMA member without using super member function. There are two-line status information for the MQS001.

**Example 3 for /DISPLAY TMEMBER command**

Entry ET:

```
/DISPLAY TMEMBER HWS001 HWS002 HWS003
```

Response ET:

| GROUP/MEMBER | XCF-STATUS | USER-STATUS    | SECURITY | TIB | INPT | SMEM |
|--------------|------------|----------------|----------|-----|------|------|
|              | DRUEXIT    | T/O            |          |     |      |      |
| HWS001       | ACTIVE     | ACCEPT TRAFFIC | FULL     | 0   | 0    | SM01 |
| HWS001       | HWSYDRU0   | 5              |          |     |      |      |
| HWS002       | ACTIVE     | ACCEPT TRAFFIC | FULL     | 0   | 0    | SM01 |
| HWS002       | HWSYDRU1   | 5              |          |     |      |      |
| HWS003       | ACTIVE     | ACCEPT TRAFFIC | FULL     | 0   | 0    |      |
| HWS003       | HWSYDRU2   | 5              |          |     |      |      |

**Explanation:** In the above example, HWS001, HWS002 and HWS003 are all regular OTMA members. OTMA hold queue output for HWS001 and HWS002 is managed by super member SM01. HWS003 manages its own OTMA hold queue output without using the super member.

**Example 4 for /DISPLAY TMEMBER command**

Entry ET:

```
/DISPLAY TMEMBER HWS001 SM01
```

Response ET:

| GROUP/MEMBER | XCF-STATUS | USER-STATUS    | SECURITY | TIB | INPT | SMEM |
|--------------|------------|----------------|----------|-----|------|------|
| HWS001       | ACTIVE     | ACCEPT TRAFFIC | FULL     | 0   | 0    | SM01 |
| SM01         |            | SUPER MEMBER   |          |     |      | SM01 |

**Explanation:** HWS001 is a regular member whose hold queue output is managed by super member SM01. SM01 is a super member. The XCF-STATUS field and the SECURITY field are left blank. The super member name is repeated in the SMEM field.

**Example 5 for /DISPLAY TMEMBER command**

Entry ET:

```
/DISPLAY TMEMBER CLIENT1 TPIPE ALL
```

Response ET:

| MEMBER/TPIPE   | ENQCT | DEQCT | QCT | STATUS  |
|----------------|-------|-------|-----|---------|
| CLIENT1        |       |       |     | TRA     |
| -TPIPE1        | 0     | 0     | 0   | TRA,STO |
| -TPIPE2        | 2     | 2     | 0   | TRA,STO |
| -TPIPE3        | 1     | 0     | 1   | TRA,STO |
| *94165/170756* |       |       |     |         |

**Example 6 for /DISPLAY TMEMBER command**



Entry ET:

```
/DIS TMEMBER CLIENT1 QCNT
```

Response ET:

```
MEMBER/TPIPE      GBLQCT      AFFINITY
CLIENT1           34          SYS3
*03203/124035*
```

**Example 7 for /DISPLAY TMEMBER command**

Entry ET:

```
/DIS TMEMBER CLIENT1 TPIPE TPIPE3 TPIPE1 QCNT
```

Response ET:

```
MEMBER/TPIPE      GBLQCT      AFFINITY
CLIENT1
-TPIPE3           16          SYS3
-TPIPE1           8           SYS3
*03202/143253*
```

**Example 8 for /DISPLAY TMEMBER command**

Entry ET:

```
/DIS TMEMBER CLIENT1 TPIPE ALL QCNT
```

Response ET:

```
MEMBER/TPIPE      GBLQCT      AFFINITY
CLIENT1
-TPIPE3           16          SYS3
-TPIPE2           16          SYS3
-TPIPE1           2           SYS3
*03202/143253*
```

**Example 9 for /DISPLAY TMEMBER command**

Entry ET:

```
/DIS TMEMBER HWS001 QCNT
```

Response ET:

```
MEMBER/TPIPE      GBLQCT      AFFINITY      SMEM
HWS001            1           SYS3          SM01
*03203/124035*
```

Explanation: HWS001 is a regular member whose hold queue output is managed by super member SM01. There is one CM0 output message on the OTMA output queue for member HWS001. That message has affinity to SYS3. The **/DIS TMEMBER QCNT** command can be issued with the super member name (SM01) specified as the member name to determine the number of messages on the super member's output queue.

**Example 10 for /DISPLAY TMEMBER command**

Entry ET:

```
/DIS TMEMBER SM01 QCNT
```

Response ET:

|                |        |          |      |
|----------------|--------|----------|------|
| MEMBER/TPIPE   | GBLQCT | AFFINITY | SMEM |
| SM01           | 46     |          | SM01 |
| *03203/124035* |        |          |      |

Explanation: SM01 is a super member. There are 46 CM0 output messages on the output queue for SM01. These messages do not have affinity to any IMS subsystem. Any member whose hold queue output is managed by SM01 can retrieve the output messages.

**Example 11 for /DISPLAY TMEMBER command**

Entry ET:

```
/DISPLAY TMEMBER HWS003 TPIPE TPIPE1
```

Response ET:

|              |       |       |     |        |      |
|--------------|-------|-------|-----|--------|------|
| MEMBER/TPIPE | ENQCT | DEQCT | QCT | STATUS | SMEM |
| HWS003       |       |       |     |        |      |
| -TPIPE1      | 3     | 2     | 1   | TRA    |      |

Explanation: HWS003 is a regular member that manages its own hold queue output. There is one output message queued for TPIPE1. This message is either on the I/O PCB output queue or the hold queue.

**Example 12 for /DISPLAY TMEMBER command**

Entry ET:

```
/DISPLAY TMEMBER HWS001 TPIPE TPIPE1
```

Response ET:

|              |       |       |     |        |      |
|--------------|-------|-------|-----|--------|------|
| MEMBER/TPIPE | ENQCT | DEQCT | QCT | STATUS | SMEM |
| HWS001       |       |       |     |        |      |
| -TPIPE1      | 0     | 0     | 0   | TRA    | SM01 |

Explanation: HWS001 is a regular member whose hold queue output is managed by super member SM01. There are no output messages queued to HWS001, but there might be some messages queued to the hold queue of super member SM01.

**Example 13 for /DISPLAY TMEMBER command**

Entry ET:

```
/DISPLAY TMEMBER SM01 TPIPE TPIPE1 TPIPE2
```

Response ET:

|              |       |       |     |        |      |
|--------------|-------|-------|-----|--------|------|
| MEMBER/TPIPE | ENQCT | DEQCT | QCT | STATUS | SMEM |
| SM01         |       |       |     |        |      |
| -TPIPE1      | 3     | 2     | 1   | TRA    |      |
| -TPIPE2      | 2     | 2     | 0   | TRA    |      |

Explanation: SM01 is a super member with transaction pipes defined for TPIPE1 and TPIPE2. Local queue count information is displayed for TPIPE1 and TPIPE2. There is one output message on the hold queue for TPIPE1.

**Example 14 for /DISPLAY TMEMBER command**

Entry ET:

```
/DIS TMEMBER SM01 TPIPE ALL QCNT
```

Response ET:

|              |        |          |      |
|--------------|--------|----------|------|
| MEMBER/TPIPE | GBLQCT | AFFINITY | SMEM |
| SM01         |        |          | SM01 |
| -TPIPE1      | 2      |          |      |
| -TPIPE2      | 5      |          |      |

-TPIPE3  
\*03202/143253\*

16

Explanation: SM01 is a super member. There are 23 CM0 output messages on the output queues for SM01. Two messages are queued for TPIPE1, five for TPIPE2 and sixteen for TPIPE3. These messages do not have affinity to any IMS subsystem. Any member whose hold queue output is managed by super member SM01 can retrieve the output messages.

**Example 15 for /DISPLAY TMEMBER command**

Entry ET:

```
/DIS TMEMBER HWS1 TPIPE ALL SYNC
```

Response ET:

```
(screen 1)
MMR/TPIP      ENQCT      DEQCT      QCT      INPCT OPT MODE
HWS1
-TPIPE1              0          0          0          0 W  S

(scrolled to the right, screen 2)
SYNCOT NO-COT RTA RTQ STATUS  SMEM      IMS1
      1      1      1      1 WAIT_S  IMS1
```

Explanation: HWS1 is a regular member with a transaction pipe defined for TPIPE1. The resume tpipe call is to retrieve only synchronous callout messages from the hold queue ("S" for MODE). The request message (from the hold queue) has been sent to the client, IMS Connect, which in turn will send the message to the application client as a result of the resume tpipe call with MODE of "S" and OPT of "W". This accounts for the count of 1 under the column heading SYNCOT. The count of 1 under the column heading NO-COT indicates that the accumulated ICAL count for this OTMA tpipe is 1. Because OTMA is waiting for ACK or NAK, WAIT\_S is displayed under column heading STATUS.

To extend the processing, assuming that the client application sends an ACK, the WAIT\_S under column heading STATUS will no longer be displayed, and the count of 1 under column heading NO-COT will still be displayed. This output indicates that OTMA has processed one ICAL message for the IMS callout application. Once the OTMA has received the message response and passed it back to the IMS callout application, SYNCOT will show 0, and NO-COT will still show 1. And, when OTMA has completed processing the message response, the resume tpipe call ends, and the output display should show OPT='-', MODE='-', SYNCOT=0, NO-COT=1, and STATUS=' '.

The number of queued tpipe requests is 1.

Entry ET:

```
/DISPLAY TMEMBER HWS1 TPIPE TPIPE1
```

Response ET:

```
MEMBER/TPIPE      ENQCT      DEQCT      QCT      INPCT STATUS  SMEM      IMS1
HWS1
-TPIPE1              0          0          0          0 WAIT_S  IMS1
```

Explanation: TPIPE1 is waiting for a NAK or ACK for a synchronous callout message.

**Example 16 for /DISPLAY TMEMBER command**

Entry ET:

```
/DISPLAY TMEMBER HWS1
```

Response ET:

```
GROUP/MEMBER      XCF-STATUS  USER-STATUS  SECURITY  TIB
INPT SMEM
          DRUEXIT  T/O  TPCNT  ACEEAGE
XCFGRP1
```

```

-HWS1          ACTIVE          MAX TPIPE      FULL          0
5000
-HWS1                200  1000  999999

```

Explanation: In this example, the TPCNT field indicates the current TPIPE count for member HWS1. MAX TPIPE indicates that the TPIPE count for the OTMA member HWS1 has reached the limit set. This status is cleared when the global TPIPE count falls below 50%.

**Example 17 for /DISPLAY TMEMBER command**

Entry ET:

```
/DISPLAY TMEMBER HWS1
```

Response ET:

```

GROUP/MEMBER      XCF-STATUS  USER-STATUS  SECURITY  TIB
INPT SMEM
      DRUEXIT  T/O TPCNT ACEEAGE MAXTP
XCFGRP1
-HWS1             ACTIVE          ACCEPT TRAFFIC FULL          0
5000
-HWS1                200  500      120    0

```

Explanation: In this example, the TPCNT field indicates that the current TPIPE count for member HWS1 is 500 and that there is no MAX TPIPE limit set for this member in the OTMA client descriptor.

**Example 18 for /DISPLAY TMEMBER command**

Entry ET:

```
/DISPLAY TMEMBER HWS2
```

Response ET:

```

GROUP/MEMBER      XCF-STATUS  USER-STATUS  SECURITY  TIB
INPT SMEM
      DRUEXIT  T/O TPCNT ACEEAGE MAXTP
XCFGRP1
-HWS2             ACTIVE          ACCEPT TRAFFIC FULL          0
5000
-HWS2                200  500      120  10000

```

Explanation: In this example, the TPCNT field indicates that the current TPIPE count for member HWS2 is 500 and that there is a MAX TPIPE limit of 10000 set for this member.

**Example 19 for /DISPLAY TMEMBER command**

Entry ET:

```
/DIS TMEM HWS1 TPIPE ALL
```

Response ET:

```

DFS000I      MEMBER/TPIPE          ENQCT      DEQCT          QCT      INPCT  STATUS
SMEM
DFS000I      HWS1
DFS000I      -9999                0          0          0          1
DFS000I      -CLIENT02            3          2          1          2
DFS000I      -CLIENT01            8          5          3          5

```

**Example 20 for /DISPLAY TMEMBER command**

Entry ET:

```
/DIS TMEM HWS1 TPIPE ALL OUTPUT
```

Response ET:

| DFS000I | MEMBER/TPIPE | ENQCT | DEQCT | QCT | INPCT | STATUS |
|---------|--------------|-------|-------|-----|-------|--------|
| SMEM    |              |       |       |     |       |        |
| DFS000I | HWS1         |       |       |     |       |        |
| DFS000I | -CLIENT03    | 1     | 1     | 0   | 1     | PMRY   |
| DFS000I | -CLIENT03    | 1     | 0     | 1   | 0     | HLDQ   |
| DFS000I | -9999        | 0     | 0     | 0   | 1     | PMRY   |
| DFS000I | -CLIENT02    | 1     | 1     | 0   | 1     | PMRY   |
| DFS000I | -CLIENT04    | 1     | 1     | 0   | 1     | PMRY   |
| DFS000I | -CLIENT04    | 1     | 0     | 1   | 0     | HLDQ   |

**Example 21 for /DISPLAY TMEMBER command**

Entry ET:

```
/DIS TMEM HWS1 TPIPE CLIENT* OUTPUT
```

Response ET:

| DFS000I | MEMBER/TPIPE | ENQCT | DEQCT | QCT | INPCT | STATUS |
|---------|--------------|-------|-------|-----|-------|--------|
| SMEM    |              |       |       |     |       |        |
| DFS000I | HWS1         |       |       |     |       |        |
| DFS000I | -CLIENT02    | 2     | 2     | 0   | 2     | PMRY   |
| DFS000I | -CLIENT02    | 1     | 0     | 1   | 0     | HLDQ   |
| DFS000I | -CLIENT01    | 5     | 5     | 0   | 5     | PMRY   |
| DFS000I | -CLIENT01    | 3     | 0     | 3   | 0     | HLDQ   |

**Example 22 of /DISPLAY TMEMBER command for TPIPEs that support multiple active resume TPIPE requests**

Entry ET:

```
/DIS TMEM HWS1 TPIPE OTMACL* OUTPUT
```

Response ET:

| DFS000I | MEMBER/TPIPE | ENQCT               | DEQCT | QCT   | INPCT  | STATUS      |
|---------|--------------|---------------------|-------|-------|--------|-------------|
| DFS000I | HWS1         |                     |       |       |        |             |
| DFS000I | -OTMACL99    | 0                   | 0     | 0     | 0      | PMRY WAIT_S |
| DFS000I | -OTMACL99    | 0                   | 0     | 0     | 0      | HLDQ        |
| DFS000I | -OTMACL99    | RT 1234567890123456 |       | OPT A | MODE B |             |
| DFS000I | -OTMACL99    | RT 1234567890123457 |       | OPT A | MODE B | WAIT_S      |
| DFS000I | -OTMACL99    | RT 1234567890123458 |       | OPT A | MODE B |             |

**Related reference**

“Status and attributes for the /DISPLAY command” on page 501

A list of the attributes and status shown in the **/DISPLAY** command are described in the following table.

“/DISPLAY OTMA command” on page 620

Use the **/DISPLAY OTMA** command to display the current status for IMS Open Transaction Manager Access (OTMA) clients and servers.

## **/DISPLAY TRACE command**

Use the **/DISPLAY TRACE** command to display the status and options of the current IMS traces. TRACE must be followed by one or more keywords or by the ALL parameter. There is no default.

Subsections:

- “Environment” on page 698
- “Syntax” on page 698
- “Keywords” on page 699
- “Usage notes” on page 699

- [“Equivalent IMS type-2 commands” on page 699](#)
- [“Output fields” on page 700](#)
- [“Examples” on page 701](#)

## Environment

The following table lists the environments (DB/DC, DBCTL, and DCCTL) in which you can use the command and keywords.

*Table 312. Valid environments for the /DISPLAY TRACE command and keywords*

| <b>Command / Keywords</b> | <b>DB/DC</b> | <b>DBCTL</b> | <b>DCCTL</b> |
|---------------------------|--------------|--------------|--------------|
| <b>/DISPLAY</b>           | X            | X            | X            |
| EXIT                      | X            |              | X            |
| LINE                      | X            |              | X            |
| LINK                      | X            |              | X            |
| LUNAME                    | X            |              | X            |
| MONITOR                   | X            | X            | X            |
| NODE                      | X            |              | X            |
| OSAMGTF                   | X            | X            |              |
| PI                        | X            | X            |              |
| PROGRAM                   | X            | X            | X            |
| PSB                       | X            | X            | X            |
| TABLE                     | X            | X            | X            |
| TCO                       | X            | X            | X            |
| TIMEOUT                   | X            |              | X            |
| TMEMBER                   | X            |              | X            |
| TRACE                     | X            | X            | X            |
| TRANSACTION               | X            |              | X            |
| TRAP                      | X            |              | X            |
| XTRC                      | X            | X            | X            |

## Syntax

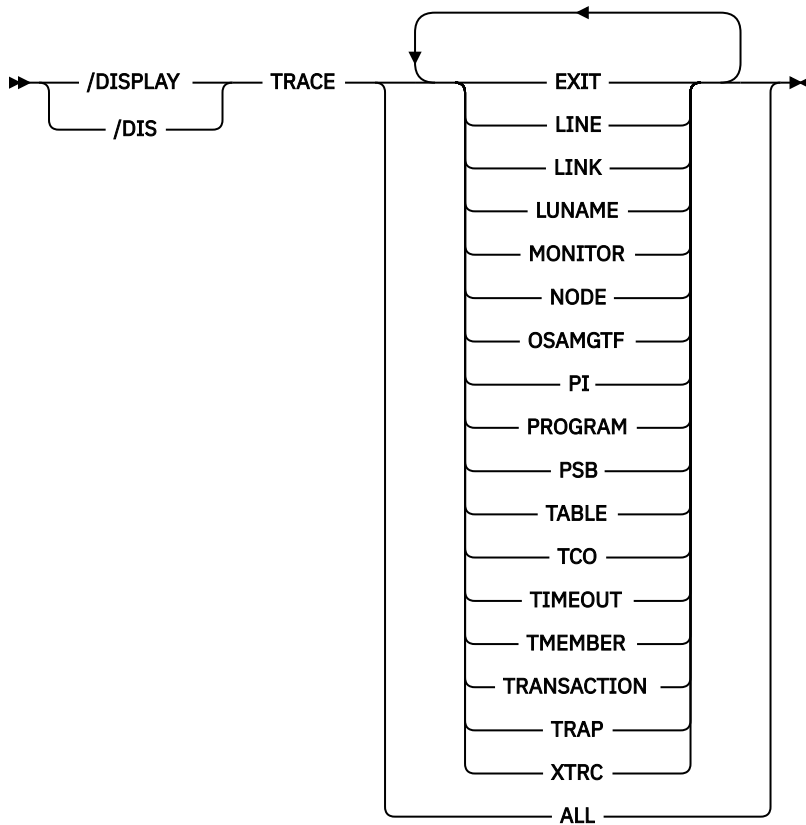

## Keywords

The following keywords are valid for the **/DISPLAY TRACE** command:

### ALL

In a DBCTL system, ALL displays only DB-related traces. It does not show DC-related traces such as LINE, LUNAME, LINK, NODE, TRANSACTION, TRAP, or TIMEOUT.

In a DCCTL system, ALL displays only DC-related traces. It does not show DB-related traces such as OSAMGTF or PI.

The display shows which external data set is active and whether the OLDS is being traced for trace logging. The command also indicates whether XTRC is usable and the status of the XTRC data sets.

For other keywords, see the descriptions for corresponding output fields under [“Output fields”](#) on page 700.

## Usage notes

The **/DISPLAY TRACE ALL** and **/DISPLAY TRACE TMEMBER** commands can be used to display IMS OTMA transaction pipes that are currently being traced for a OTMA client. The command output includes transaction pipes that are defined to super members. The super member name is displayed if the member is a super member or if the member is a regular member whose hold queue output is managed by a super member.

## Equivalent IMS type-2 commands

The following table shows variations of the **/DISPLAY TRACE** command and the IMS type-2 commands that perform similar functions.

*Table 313. Type-2 equivalents for the /DISPLAY TRACE command*

| <b>Task</b>                       | <b>/DISPLAY TRACE command</b> | <b>Similar IMS type-2 command</b> |
|-----------------------------------|-------------------------------|-----------------------------------|
| Displays nodes with trace status. | /DISPLAY TRACE NODE           | QUERY NODE STATUS(TRACE)          |

## Output fields

The following output fields are displayed by the **/DISPLAY TRACE** command:

### EXIT

Displays user exit tracing. Currently, only tracing for the DFSMSCEO user exit is supported. The following table lists the display exit entry points.

*Table 314. Display exit entry points for tracing*

| <b>List #1</b> | <b>List #2</b> | <b>List #3</b> | <b>List #4</b> |
|----------------|----------------|----------------|----------------|
| LRDI           | LRIN           | LRLT           | LRTR           |
| PRCH           | PRGU           | PRIS           | TR62           |
| TRBT           | TROT           | TRVT           |                |

**Note:** The display indicates the status of each exit entry point. If the status is ON, the trace is active for the selected entry point. If the status is OFF, the trace is inactive for the selected entry point. If the status is N/A, the specified DFSMSCEO trace entry point does not exist in the IMS.

### LINE

The relative line number and line type of all traced lines.

### LINK

The link number and link partner for all logical links.

### LUNAME

All LU 6.2 application programs that are being traced.

### OSAMGTF

Whether the OSAM Buffer Trace facility is active or inactive.

### MONITOR

The status of the IMS Monitor, and if active, the options that are specified for it.

### NODE

The VTAM or ISC TCP/IP node name and the node type. If the node is defined for a parallel session, each traced user of that node is displayed. If the users are not active, an N/A is displayed.

### PI

The status of the program isolation trace, and if active, the status of the options and the volume level.

### PROGRAM

The traced program name.

### PSB

The PSB name and trace option for each traced PSB.

### TABLE

The trace status, logging status, total number of entries in each trace table, and the volume level.

For a DL/I trace, the volume level is displayed in the subcategories.

In an IMSplex, the OCMD, RM, and SCI table traces are included in the table traces displayed.

### TCO

Displays whether tracing is active for the Time Controlled Operation (TCO).



## TIMEOUT

The status of the IMS VTAM I/O Timeout Detection Facility, including the specifications given when the **/TRACE SET ... TIMEOUT** command was issued. The **/DISPLAY TRACE TIMEOUT** command will show active or inactive status, the timeout value in minutes, and the action to be taken when timeout occurs (AUTO, MSG, or no action). Option and Timeout values will be displayed only when the facility is active.

## TMEMBER

The IMS Open Transaction Manager Access (OTMA) transaction pipes that are currently being traced for the OTMA client.

## TRANSACTION

The name of the transaction and the applicable PSB name for each trace.

## TRAP

The trap that is currently set, either 1 or 2; that trap is enabled for MFS serviceability aids.

## XTRC

External trace status. Whether XTRC is usable and the status of the XTRC data sets are also displayed.

## Examples

The following are examples of the **/DISPLAY TRACE** command.

### Example 1 for /DISPLAY TRACE command

Entry ET:

```
/DISPLAY TRACE ALL
```

Response ET:

```
IMS ACTIVE TRACES
```

```
LINE      TYPE
   1  CONSOLE
   4  3270 R
```

```
LINK      PARTNER
   2       AC
```

```
NODE      TYPE      USERS
SLUP1     SLUP
LU6NDPA   LUT6   N/A      N/A      N/A
VAT11     3277
```

```
NO PSB TRACES FOUND
```

```
MONITOR IS INACTIVE
```

```
TRAN CODE      PSB-NAME
ADDINV         DFSSAM04
```

```
PROGRAM NAME
APOL1
DEBS
TACP1
```

| TABLE | TRACE | LOGGING | ENTRIES | VOLUME | SYS3 |
|-------|-------|---------|---------|--------|------|
| RETR  | ON    | N/A     | 128/PST | N/A    | SYS3 |
| DL/I  |       | OFF     | 2268    |        | SYS3 |
| DL/I  | ON    |         |         | HIGH   | SYS3 |
| LOCK  | ON    |         |         | HIGH   | SYS3 |
| PI    | OFF   |         |         | OFF    | SYS3 |
| LATC  | ON    | OFF     | 3024    | MEDIUM | SYS3 |
| DISP  | ON    | OFF     | 1260    | MEDIUM | SYS3 |
| SCHD  | ON    | OFF     | 630     | MEDIUM | SYS3 |
| SUBS  | OFF   | OFF     | 504     | OFF    | SYS3 |
| DLOG  | ON    | OFF     | 756     | MEDIUM | SYS3 |

|      |     |     |      |        |      |
|------|-----|-----|------|--------|------|
| FAST | OFF | OFF | 252  | OFF    | SYS3 |
| STRG | ON  | OFF | 1260 | MEDIUM | SYS3 |
| IDC0 | OFF | OFF | 2268 | OFF    | SYS3 |
| LUMI | OFF | OFF | 1512 | OFF    | SYS3 |
| OTMT | OFF | OFF | 1008 | OFF    | SYS3 |
| QMGR | ON  | OFF | 1008 | MEDIUM | SYS3 |
| ORTT | OFF | OFF | 1008 | OFF    | SYS3 |
| OCMD | OFF | OFF | 1008 | OFF    | SYS3 |
| CSLT | OFF | OFF | 1008 | OFF    | SYS3 |
| RRST | OFF | OFF | 1512 | OFF    | SYS3 |
| MSCT | OFF | OFF | 1260 | OFF    | SYS3 |
| FPTT | OFF | OFF | 1008 | OFF    | SYS3 |
| DIAG | ON  | ON  | 8064 | MEDIUM | SYS3 |
| SECT | OFF | OFF | 1008 | OFF    | SYS3 |

**Example 2 for /DISPLAY TRACE command**

Entry ET:

```
/DISPLAY TRACE LINE LINK NODE
```

Response ET:

```
IMS ACTIVE TRACES
LINE      TYPE
  1  CONSOLE
  30 3270 R
  30 3270 R
LINK  PARTNER
  4   RF
NODE      TYPE  USERS
L3270A   3277
LU6NDPA  LUT6  N/A   N/A   N/A
LEVEL: 4  MODULE: ALL
*90290/143519*
```

**Example 3 for /DISPLAY TRACE command**

Entry ET:

```
/DISPLAY TRACE LUNAME
```

Response ET:

```
IMS ACTIVE TRACES
LUNAME  TPNAME
LUNAME3          INPUT
LUNAME3 TPNAME1   OUTPUT
LUNAME3 TPNAME7890123456+ OUTPUT
          789END
LUNAME4          INPUT
*90332/114253*
```

Entry ET:

```
/DISPLAY TRACE LUNAME
```

Response ET:

```
IMS ACTIVE TRACES
LUNAME/TPNAME
NET1.LU1      INP
-TPN1
NET2.LU1      OUTP
-TPN2         OUTP
LU3           INP,  OUTP
-TPN3         OUTP
-TPN4         OUTP
NET4.LU3     OUTP
```

```
NET5.LU5      INP
*93069/114435*
```

#### **Example 4 for /DISPLAY TRACE command**

Entry ET:

```
/DISPLAY TRACE OSAMGTF
```

Response ET:

```
IMS ACTIVE TRACES
OSAMGTF TRACE IS INACTIVE
*92107/090819
```

Entry ET:

```
/TRACE SET ON OSAMGTF
```

Response ET:

```
DFS058I 09:08:32 TRACE COMMAND COMPLETED
```

Entry ET:

```
/DISPLAY TRACE OSAMGTF
```

Response ET:

```
IMS ACTIVE TRACES
OSAMGTF TRACE IS ACTIVE
*92107/090841*
```

#### **Example 5 for /DISPLAY TRACE command**

Entry ET:

```
/DISPLAY TRACE MONITOR
```

Response ET:

```
IMS ACTIVE TRACES
MONITOR IS ACTIVE:  LA SCHD APMQ APDB
                    APDB dbname/partition-name/area-name ...
                    REGION reg# ... region-name ...
                    INTERVAL #seconds EXPIRING hh:mm:ss.tt
*98029/114114*
```

#### **Example 6 for /DISPLAY TRACE command**

Entry ET:

```
/TRACE SET ON TABLE QMGR
/TRACE SET ON TABLE SQTT
/DISPLAY TRACE TABLE
```

Response ET:

```
IMS ACTIVE TRACES  SYS3S Volume  SYS3
SYS3  N/A  128/PST  N/A  SYS3
TABLE  TRACE  LOGGING  ENTRIES  VOLUME  SYS3
RETR   ON    N/A    128/PST  N/A    SYS3
DL/I   OFF    OFF    2268    HIGH   SYS3
DL/I   ON    OFF    2268    HIGH   SYS3
LOCK   ON    OFF    2268    HIGH   SYS3
PI     OFF    OFF    2268    OFF    SYS3
LATC   ON    OFF    3024    MEDIUM  SYS3
DISP   ON    OFF    1260    MEDIUM  SYS3
SCHD   ON    OFF    630    MEDIUM  SYS3
SUBS   OFF    OFF    504    OFF     SYS3
```

|                |     |      |      |        |      |
|----------------|-----|------|------|--------|------|
| DLOG           | ON  | OFF  | 756  | MEDIUM | SYS3 |
| FAST           | OFF | OFF  | 252  | OFF    | SYS3 |
| STRG           | ON  | OFF  | 1260 | MEDIUM | SYS3 |
| IDC0           | OFF | OFF  | 2268 | OFF    | SYS3 |
| LUMI           | OFF | OFF  | 1512 | OFF    | SYS3 |
| OTMT           | OFF | OFF  | 1008 | OFF    | SYS3 |
| QMGR           | ON  | OFF  | 1008 | MEDIUM | SYS3 |
| ORTT           | OFF | OFF  | 1008 | OFF    | SYS3 |
| OCMD           | OFF | OFF  | 1008 | OFF    | SYS3 |
| CSLT           | OFF | OFF  | 1008 | OFF    | SYS3 |
| RRST           | OFF | OFF  | 1512 | OFF    | SYS3 |
| MSCT           | OFF | OFF  | 1260 | OFF    | SYS3 |
| FPTT           | OFF | OFF  | 1008 | OFF    | SYS3 |
| DIAG           | ON  | ON   | 8064 | MEDIUM | SYS3 |
| SECT           | OFF | OFF  | 1008 | OFF    | SYS3 |
| *04197/152006* |     | SYS3 |      |        |      |

**Example 7 for /DISPLAY TRACE command**

Entry ET:

```
/DISPLAY TRACE TCO
```

Response ET:

```
IMS ACTIVE TRACES
TCO IS NOT ACTIVE
*89100/170509*
```

**Example 8 for /DISPLAY TRACE command**

Entry ET:

```
/DISPLAY TRACE TIMEOUT
```

Response ET:

```
IMS ACTIVE TRACES
VTAM I/O TIMEOUT FACILITY IS INACTIVE
*89033/170200*
```

**Example 9 for /DISPLAY TRACE command**

Entry ET:

```
/DISPLAY TRACE TIMEOUT
```

Response ET:

```
IMS ACTIVE TRACES
VTAM I/O TIMEOUT FACILITY IS ACTIVE
OPTION = NONE    TIMEOUT VALUE = 0
*89110/131429*
```

**Example 10 for /DISPLAY TRACE command**

Entry ET:

```
/DISPLAY TRACE TIMEOUT
```

Response ET:

```
IMS ACTIVE TRACES
VTAM I/O TIMEOUT FACILITY IS ACTIVE
OPTION = AUTO    TIMEOUT VALUE = 10
```

\*89033/170200\*

**Example 11 for /DISPLAY TRACE command**

Entry ET:

/DISPLAY TRACE TIMEOUT

Response ET:

```
IMS ACTIVE TRACES
VTAM I/O TIMEOUT FACILITY IS ACTIVE
  OPTION = MSG      TIMEOUT VALUE = 60
*89033/131630*
```

**Example 12 for /DISPLAY TRACE command**

Entry ET:

/DISPLAY TRACE TMEMBER

Response ET:

```
IMS ACTIVE TRACES
TMEMBER/TPIPE      TYPE
CLIENT1
-TPIPE1            TRA
*94168/095325*
```

**Example 13 for /DISPLAY TRACE command**

Entry ET:

/DISPLAY TRACE XTRC

Response ET:

```
IMS ACTIVE TRACES
IMS EXTERNAL TRACE IS  USABLE
  SYS3
XTRC DDNAME  ALLOC STATUS      STATUS
DFSTRA01    DYNA  UNALLOCATED  CLOSED
DFSTRA02    DYNA  UNALLOCATED  CLOSED
DFSTRA0T    DYNA  UNALLOCATED  CLOSED
*91091/124215*
```

**Example 14 for /DISPLAY TRACE command**

Entry ET:

/DIS TRACE EXIT

Response ET:

```
55/DIS TRACE EXIT
IEE600I REPLY TO 55 IS;/DIS TRACE EXIT
DFS000I      IMS ACTIVE TRACES  IMS3
DFS000I      IMS3
DFS000I      EXIT      FUNC  STATUS  IMS3
DFS000I      DFSMSCE0  TRBT   ON      IMS3
DFS000I      DFSMSCE0  TRVT   ON      IMS3
DFS000I      DFSMSCE0  TR62  OFF     IMS3
DFS000I      DFSMSCE0  TR0T  OFF     IMS3
DFS000I      DFSMSCE0  LRTR  ON      IMS3
DFS000I      DFSMSCE0  LRLT  ON      IMS3
```

```

DFS000I      DFMSMCE0      LRDI      ON      IMS3
DFS000I      DFMSMCE0      LRIN      ON      IMS3
DFS000I      DFMSMCE0      PRCH      ON      IMS3
DFS000I      DFMSMCE0      PRIS      N/A     IMS3
DFS000I      DFMSMCE0      PRGU      ON      IMS3
DFS000I      *99096/103002*  IMS3
56 DFS996I *IMS READY*  IMS3

```

Response ET:

```

39/DIS TRACE EXIT
IEE600I REPLY TO 39 IS;/DIS TRACE EXIT
DFS000I      IMS ACTIVE TRACES      IMS3
DFS000I      IMS3
DFS000I      EXIT      FUNC      STATUS      IMS3
DFS000I      DFMSMCE0      TRBT      N/A      IMS3
DFS000I      DFMSMCE0      TRVT      N/A      IMS3
DFS000I      DFMSMCE0      TR62      N/A      IMS3
DFS000I      DFMSMCE0      TROT      N/A      IMS3
DFS000I      DFMSMCE0      LRTR      N/A      IMS3
DFS000I      DFMSMCE0      LRLT      N/A      IMS3
DFS000I      DFMSMCE0      LRDI      N/A      IMS3
DFS000I      DFMSMCE0      LRIN      N/A      IMS3
DFS000I      DFMSMCE0      PRCH      N/A      IMS3
DFS000I      DFMSMCE0      PRIS      N/A      IMS3
DFS000I      DFMSMCE0      PRGU      N/A      IMS3
DFS000I      *99105/222611*  IMS3
46 DFS996I *IMS READY*  IMS3

```

### Example 15 for /DISPLAY TRACE Command

Entry ET:

```

/DISPLAY TRACE TMEMBER

```

Response ET:

```

IMS ACTIVE TRACES
TMEMBER/TPIPE      TYPE      SMEM
HWS001              SM01
-TPIPE1              TRA
SM01                SM01
-TPIPE1              TRA
-TPIPE2              TRA
HWS003
-TPIPE1              TRA
*05049/095325*

```

Explanation: HWS001 is a regular member whose hold queue output is managed by super member SM01. HWS001 has one transaction pipe that is being traced. SM01 is a super member with two transaction pipes that are being traced. HWS003 also has a transaction pipe that is being traced. HWS003 is a regular member that manages its own hold queue output.

### Example 16 for /DISPLAY TRACE command

Entry ET:

```

/DISPLAY TRACE TABLE

```

Response ET:

```

IMS ACTIVE TRACES SYS3S Volume SYS3
SYS3 N/A 128/PST N/A SYS3
TABLE TRACE LOGGING ENTRIES VOLUME SYS3
RETR ON N/A 128/PST N/A SYS3
DL/I OFF 2268 SYS3
DL/I ON HIGH SYS3
LOCK ON HIGH SYS3
PI OFF OFF SYS3
LATC ON OFF 3024 MEDIUM SYS3
DISP ON OFF 1260 MEDIUM SYS3
SCHD ON OFF 630 MEDIUM SYS3
SUBS OFF OFF 504 OFF SYS3

```

```

DLOG  ON   OFF   756    MEDIUM SYS3
FAST  OFF  OFF   252    OFF     SYS3
STRG  ON   OFF   1260   MEDIUM SYS3
IDCO  OFF  OFF   2268   OFF     SYS3
LUMI  OFF  OFF   1512   OFF     SYS3
OTMT  OFF  OFF   1008   OFF     SYS3
QMGR  ON   OFF   1008   MEDIUM SYS3
ORRT  OFF  OFF   1008   OFF     SYS3
OCMD  ON   OFF   1008   ERROR  SYS3
CSLT  OFF  OFF   1008   OFF     SYS3
RRST  OFF  OFF   1512   OFF     SYS3
MSCT  OFF  OFF   1260   OFF     SYS3
FPTT  OFF  OFF   1008   OFF     SYS3
DIAG  ON   ON    8064   MEDIUM SYS3

SECT  OFF  OFF   1008   OFF     SYS3
*04197/152006* SYS3

```

### Example 17 for /DISPLAY TRACE command

The following example shows the output returned for ISC TCP/IP nodes.

Entry ET:

```
/DISPLAY TRACE TABLE
```

Response ET:

```

IMS ACTIVE TRACES

NODE      TYPE  USERS
CICS      TCP   IMSUS01
LU6NDPA   TCP   LU6SPA

LEVEL: 4   MODULE: ALL
*12062/122024*

```

### Related reference

[QUERY NODE command \(Commands\)](#)

## /DISPLAY TRAN command

Use the **/DISPLAY TRAN** command to display the status of transactions.

Subsections:

- [“Environment” on page 707](#)
- [“Syntax” on page 708](#)
- [“Keywords” on page 708](#)
- [“Usage notes” on page 709](#)
- [“Equivalent IMS type-2 commands” on page 709](#)
- [“Output fields” on page 709](#)
- [“Examples” on page 710](#)

### Environment

The following table lists the environments (DB/DC, DBCTL, and DCCTL) in which you can use the command and keywords.

Table 315. Valid environments for the /DISPLAY TRAN command and keywords

| Command / Keywords | DB/DC | DBCTL | DCCTL |
|--------------------|-------|-------|-------|
| <b>/DISPLAY</b>    | X     | X     | X     |

Table 315. Valid environments for the /DISPLAY TRAN command and keywords (continued)

| Command / Keywords | DB/DC | DBCTL | DCCTL |
|--------------------|-------|-------|-------|
| QCNT               | X     |       | X     |
| TRAN               | X     |       | X     |

## Syntax

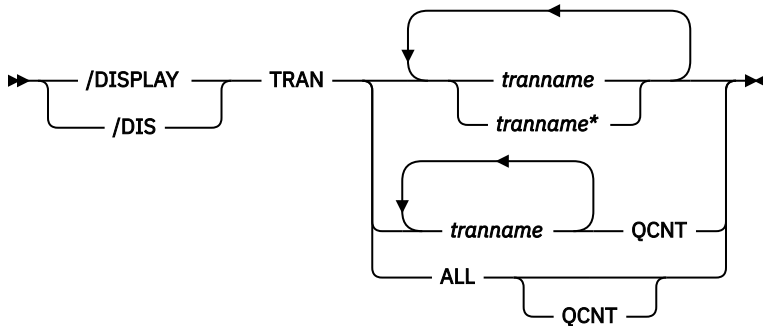

## Keywords

The following keyword can be specified for the **/DISPLAY TRAN** command:

### QCNT

Specifies that global queue count information is to be displayed. If the QCNT keyword is not specified, local queue counts are displayed. The QCNT keyword is valid only in a shared-queues environment.

IMS does not check that the specified name is a valid transaction in the IMS subsystem on which the command is entered.

The **/DIS TRAN tranname QCNT** command returns the count of messages on the shared-queue structure for transaction *tranname*. The message count includes the messages that can be processed by any IMS (messages with no affinity), plus messages that can be processed only by the IMS where the **/DIS TRAN** command was entered (messages with affinity to the IMS that issued the command). Thus, a **/DIS TRAN tranname QCNT** command that is routed to several IMS subsystems in an IMSplex environment might show different queue counts on different IMS subsystems if there are messages on the shared-queue structure that are queued with affinity to an IMS.

The **/DISPLAY TRAN ALL QCNT** command displays all the transactions on the shared queues with a global queue count. This command returns one line for each transaction that has messages queued to the global (non-affinity) queue on the shared queue structure. This line shows the number of messages that are queued to the global queue of that transaction and indicates the messages that can be processed by any IMS. Additionally, the **/DIS TRAN ALL QCNT** command returns one line for each transaction that has messages queued with affinity to an IMS in the IMSplex. This line shows the number of messages queued with affinity, as well as the IMSID of the IMS to which they have affinity.

On the IMS where this message will be processed, you might need to register this transaction for affinity message processing by entering a type-1 **/START TRAN tranname AFFINITY** command or a type-2 **UPDATE TRAN NAME(tranname) START(SCHD) OPTION(AFFIN)** command.

For the AFFINITY status, the type-1 command can display messages on the shared queues that have affinity, but not the local AFFINITY status of the transaction (*trancode*) name in IMS. To query the affinity status of a transaction, use a type-2 **QUERY TRAN STATUS(AFFIN)** command or a **QUERY TRAN NAME(tranname) SHOW(STATUS)** command.



## Usage notes

The TRAN keyword parameter can be generic.

IMS Open Transaction Manager Access (OTMA) supports an architected format for the output from the **/DISPLAY TRAN** command. The architected output is returned to the OTMA client, not to an IMS operator.

In a shared-queues environment, use the QCNT keyword to obtain the current message queue counts on the shared queues structure. The local queue counts (ENQCT, DEQCT, and QCT) value that is returned on this command when the QCNT keyword is not specified represents the messages being processed by the IMS system where this command is issued. Do not use local queue counts for queue evaluation purposes.

## Equivalent IMS type-2 commands

The following table shows variations of the **/DISPLAY TRAN** command and the IMS type-2 commands that perform similar functions.

Table 316. Type-2 equivalents for the **/DISPLAY TRAN** command

| Task   | <b>/DISPLAY TRAN</b> command              | Similar IMS type-2 command                       |
|--|---|--|
| Displays information about a transaction.  | <b>/DISPLAY TRAN</b> <i>tranname</i>      | QUERY TRAN NAME( <i>tranname</i> )<br>SHOW(ALL)  |
| Displays all of the transactions.  | <b>/DISPLAY TRAN</b> ALL                  | QUERY TRAN SHOW(ALL)                             |
| Displays all of the transactions on the shared queues with a global queue count. | <b>/DISPLAY TRAN</b> <i>tranname</i> QCNT | QUERY TRAN NAME( <i>tranname</i> )<br>SHOW(QCNT) |

## Output fields

The **/DISPLAY TRAN** command displays the transaction name, class (CLS), current priority(CP), normal priority (NP), limit priority (LP), local enqueue queue count (ENQCT), local queue count (QCT), limit count (LCT), processing limit count (PLCT), parallel limit count (PARLM), the number and size of output segments for a specified transaction code (SESZ, SEGN0), and the number of regions the transaction is currently scheduled in (RC), all on the first line.

The next two indented lines show the PSB name associated with the transaction and the status. DFSPIC is displayed as the PSB name for CPI Communications driven transactions that have not issued a DL/I APSB call to allocate a PSB.

Fast Path exclusive transaction codes have only the transaction code and class returned, where the class is displayed as FPE. The queue counts are not shown because Fast Path processing bypasses the IMS message queues.

Fast Path potential transactions have two lines returned, the first line with the transaction code and class, where the class is displayed as FPP, and the second line with the transaction information.

For remote transactions, the class column is displayed as RMT.

The status displayed can be one of the following:

```
BAL
DYNAMIC
I/O PREV
LOCK
NOTINIT
PSTOP
PUR
QERR
QSTP
SPND
```

```
STOP
TRA
USTOP
```

A status of NOINIT appears in the output of a **/DISPLAY TRAN** command when IMS is unable to initialize a transaction resource during restart processing.

The **/DISPLAY TRAN** command also displays I/O prevention when a BMP program containing GSAM cannot complete scheduling.

The **/DISPLAY TRAN QCNT count** command returns the global queue counts from shared queues and any affinity of messages on the IMS shared queues.

## Examples

The following are examples of the **/DISPLAY TRAN** command.

### Example 1 for /DISPLAY TRAN command

Entry ET:

```
/DISPLAY TRAN ALL
```

Response ET:

```
TRAN  CLS  ENQCT  QCT  LCT  PLCT  CP  NP  LP  SEGSZ  SEGNO  PARLM  RC
TPN1   22   14     7    5    0   8   5   8    0     0     0   5
  PSBNAME: DFSCPIC
TPN2   23   16     0    0    0   0   0   0    0     0     0   0
  PSBNAME: DFSCPIC
  STATUS: PUR
TPN2   24    0     0    0    0   0   0   0    0     0     0   0
  PSBNAME: DFSCPIC
  STATUS: STOP
TRAN1   4    0     0   10    5   8   8  10    0     0     2   2
  PSBNAME: LU2PGM1
TRAN2   7    0     0 65535 65535  8   8   8    0     0     0   0
  PSBNAME: LU2PGM2
  STATUS: PSTOP
*90332/114253*
```

### Example 2 for /DISPLAY TRAN command

Entry ET:

```
/DISPLAY TRAN SKS1 SKS2 SKS3 SKS4 SKS5 SKS6 SKS7
```

Response ET:

```
TRAN  CLS  ENQCT  QCT  LCT  PLCT  CP  NP  LP  SEGSZ  SEGNO  PARLM  RC
SKS1   1    0     0 65535 65535  8   8   8    0     0     0   0
  PSBNAME: DFSDDL1
  STATUS: TRA
SKS2   2    0     0 65535 65535  8   8   8    0     0     0   0
  PSBNAME: DFSDDL2
SKS3   3    0     0 65535 65535  8   8   8    0     0     0   0
  PSBNAME: DFSDDL3
  STATUS: STOP,TRA
SKS4   4    0     0 65535 65535  8   8   8    0     0     0   0
  PSBNAME: DFSDDL4
  STATUS: STOP
SKS5   5    0     0 65535 65535  8   8   8    0     0     0   0
  PSBNAME: DFSDDL5
SKS6   6    0     0 65535 65535  8   8   8    0     0     2   0
  PSBNAME: DFSDDL6
  STATUS: BAL( 2)
SKS7   7    0     0 65535 65535  8   8   8    0     0     1   0
  PSBNAME: DFSDDL7
```

```
STATUS: BAL( 2)
*89184/142345*
```

### Example 3 for /DISPLAY TRAN command

Entry ET:

```
/DISPLAY TRAN TRANA TRANB TRANC QCNT
```

Response ET:

```
TRAN      GBLQCT
TRANA      0
TRANB     1000
TRANC      45
*95200/170817*
```

### Example 4 for /DISPLAY TRAN command

Entry ET:

```
/DISPLAY TRAN ALL QCNT
```

Response ET:

```
TRAN      GBLQCT  AFFINITY
TRAN1234  1524    IMS1
TRAN1234   3     IMSA
TRAN1234   14
*00305/103034*
```

Explanation: This example command receives multiple lines of output for a transaction, TRAN1234. The output shows there are 1524 messages for the transaction that have an affinity to execute on IMS1. A transaction might have an affinity if it were an APPC, OTMA, or serial transaction. If an output line shows no affinity, like the example output line with a GBLQCT of 14, then there could be a single IMS system indicated, or multiple IMS systems that have messages that contribute to the GBLQCT.

### Example 5 for /DISPLAY TRAN command

Entry ET:

```
/DISPLAY TRAN ALL QCNT
```

Response ET:

```
DFS000I   TRAN      GBLQCT  AFFINITY
DFS000I   APOL12     1
DFS000I   APOL12     1  IMS1
```

Explanation: This example shows two messages queued to transaction APOL12. One message has affinity to IMS1. The other message does not.

### Related reference

[“Status and attributes for the /DISPLAY command” on page 501](#)

A list of the attributes and status shown in the **/DISPLAY** command are described in the following table.

[QUERY TRAN command \(Commands\)](#)

## /DISPLAY UOR command

Use the **/DISPLAY UOR** command to display status information about IMS units of recovery (UORs) for protected resources on the z/OS Resource Recovery Services (RRS) platform.

Subsections:

- [“Environment” on page 712](#)
- [“Syntax” on page 712](#)

- “Keywords” on page 712
- “Output fields” on page 712
- “Examples” on page 713

## Environment

The following table lists the environments (DB/DC, DBCTL, and DCCTL) in which you can use the command and keywords.

Table 317. Valid environments for the /DISPLAY UOR command and keywords

| Command / Keywords | DB/DC | DBCTL | DCCTL |
|--------------------|-------|-------|-------|
| /DISPLAY           | X     | X     | X     |
| ACTIVE             | X     | X     | X     |
| INDOUBT            | X     | X     |       |
| UOR                | X     | X     |       |

## Syntax

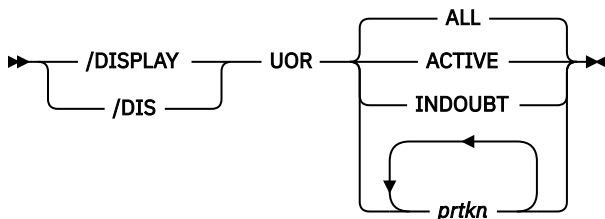

## Keywords

The following keywords are valid for the /DISPLAY UOR command:

### **ALL**

Displays active and indoubt UORs. ALL is the default.

### **ACTIVE**

Displays only active UORs.

### **INDOUBT**

Displays only UORs that were indoubt when they were terminated. Indoubt UORs identify residual work that needs resolution.

### ***prtkn***

If you specify the 6-byte pseudorecovery token of the protected UOR, this command displays information about the requested UOR.

## Output fields

The following output fields are displayed by the /DISPLAY UOR command:

### **EID**

The identifier of a work request across multiple connected distributed systems coordinated by the Encina toolkit. This data appears on a separate line of output if it is available.

**IMS-RECTOKN**

The IMS recovery token that uniquely identifies the IMS portion of the UOR.

**LUWID**

The identifier of a work request across multiple distributed systems connected by LU 6.2 conversations. This data appears on a separate line of output if it is available.

**PSBNAME**

The IMS PSB scheduled for this UOR.

**P-TOKEN**

The IMS pseudorecovery token, which can be used in subsequent commands to refer to this particular UOR. This token only displays for indoubt UORs (status RI). Use this token for subsequent **/DISPLAY UOR** and **/CHANGE UOR** commands.

**RRS-URID**

The unique identifier for a protected unit of recovery (of which IMS work is part). z/OS Resource Recovery Services (RRS) generates and maintains this data.

**ST**

Status of the UOR, which can be one of the following:

**A**

Active; work is in flight.

**B**

Active; work is being backed out.

**C**

Active; work is being committed.

**E**

Active; work is in cleanup phase.

**I**

Active; work is indoubt, awaiting phase 2 action.

**RI**

Residual indoubt; indoubt UOR from a prior IMS execution or a dependent-region abend.

**WID**

The identifier of a work request across multiple distributed systems that are not associated with a LUWID, EID, or XID task. This data is provided only for the **/DIS UOR ACTIVE** command, and appears on a separate line of output.

**XID**

X/Open identifier (XID). One possible work identifier for a distributed transaction used by a communications resource manager that uses X/Open distributed transaction processing model.

**Examples****Example 1 for /DISPLAY UOR command**

Entry ET:

```
/DISPLAY UOR
```

Response ET:

```
ST P-TOKEN PSBNAME RRS-URID IMS-TOKEN
A DBOVLFPC AF3499A27EC3E298000000401010000 SYS1 0000000400000002
EID=0001812223768AC1009B5870268346
C DBOVLFPC AF1124A27EE1C2380000000501020000 SYS1 0000000700000002
EID=0002A35549021DA108538121766899670
RI 00010120 PLAPJK02 12345678901234567890123456789012 SYS1 0000001300000001
EID=0001C35549021DB176523121445797320
*96337/145345*
```



## **/DISPLAY USER command**

---

Use the **/DISPLAY USER** command to display all of the user structures and the user IDs that match the parameter or attribute specified.

Subsections:

- [“Environment” on page 715](#)
- [“Syntax” on page 715](#)
- [“Keywords and reserved parameters” on page 716](#)
- [“Usage notes” on page 717](#)
- [“Equivalent IMS type-2 commands” on page 718](#)
- [“Examples” on page 719](#)

### **Environment**

The following table lists the environments (DB/DC, DBCTL, and DCCTL) in which you can use the command and keywords.

*Table 318. Valid environments for the /DISPLAY USER command and keywords*

| <b>Command / Keywords</b> | <b>DB/DC</b> | <b>DBCTL</b> | <b>DCCTL</b> |
|---------------------------|--------------|--------------|--------------|
| <b>/DISPLAY</b>           | X            | X            | X            |
| AUTOLOGON                 | X            |              | X            |
| EMHQ                      | X            |              | X            |
| QCNT                      | X            |              | X            |
| RECOVERY                  | X            | X            |              |
| USER                      | X            |              | X            |

### **Syntax**

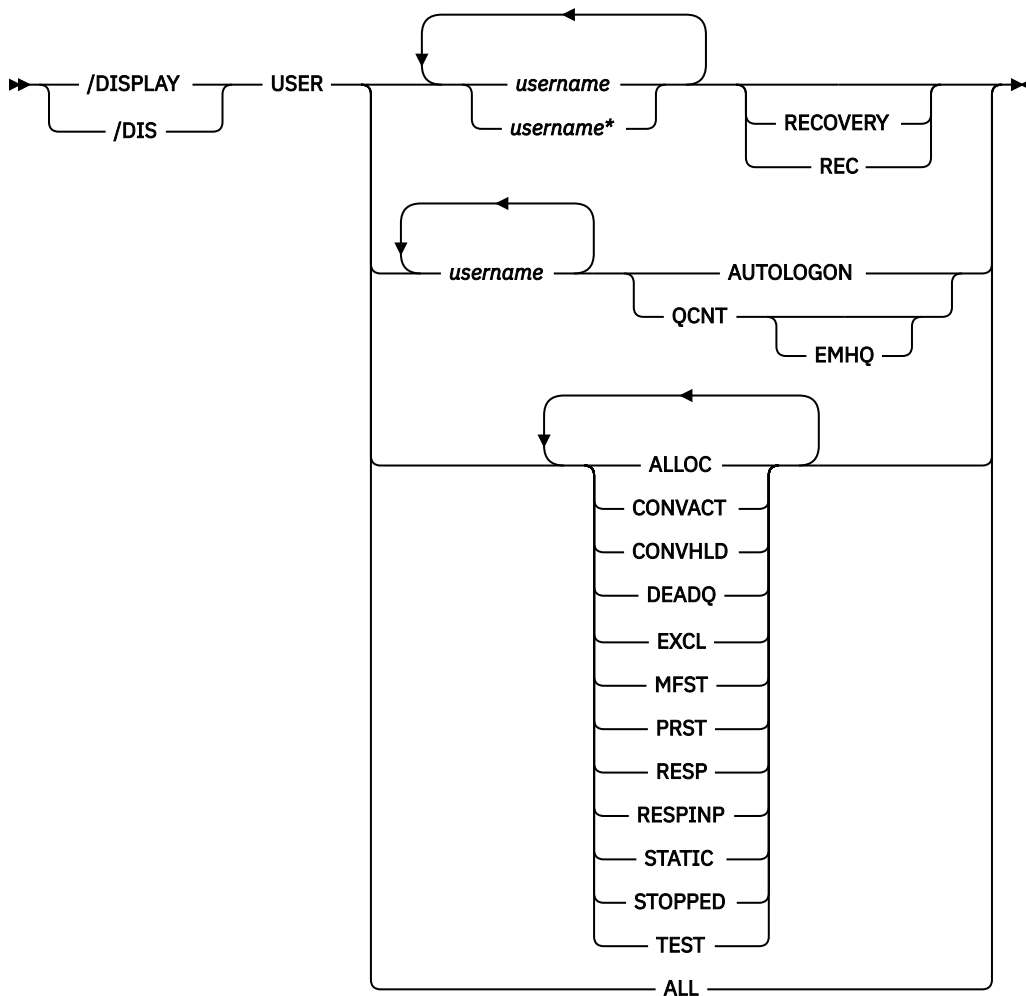

## Keywords and reserved parameters

The following keywords can be specified for the `/DISPLAY USER` command:

### AUTOLOGON

Displays the current autologon information for the specified user. The autologon information can be changed dynamically with the `/CHANGE` command.

### EMHQ

Specifies that global queue count information on the Expedited Message Handler Queues (EMHQ) displays when both EMHQ and QCNT are specified. If EMHQ is specified, QCNT must also be specified. This keyword is valid only in a shared-queues environment.

### QCNT

Specifies that global queue count information is to be displayed. If QCNT is not specified, local queue counts are displayed; when it is specified, no local queue counts are displayed. If QCNT is specified and EMHQ is not, global queue count information on the shared message queues (MSGQ) is displayed.

This count represents the message counts of messages that can be processed by the IMS system where the command is issued. This count includes messages that can be processed by any IMS system (messages with no affinity), plus messages that can be processed by the IMS system where the command is issued (messages with an affinity to the IMS system that issued the command).

IMS does not check if the specified name is a valid LTERM in the IMS subsystem on which the command is entered.



This command does not display queue counts for Fast Path output messages for the NODE unless EMHQ and QCNT are specified.

This keyword is valid only in a shared-queues environment.

## RECOVERY

The **/DISPLAY NODE|USER RECOVERY** command can be used to display the recovery values that pertain to the node or user. The recovery values may be displayed from the local control blocks, if available, or from values saved for the node or user in the Resource Manager, if resource information is being kept in Resource Manager, and the node or user is defined to have its status kept in Resource Manager. The recovery information displayed with this command are:

- IMS owner
- The IMS ID (RSEname if an XRF system) of the IMS system that currently owns this resource. If the resource is not currently owned, this field will be displayed as NONE.
- The scope of recovery for a resource, and from where the end-user significant status is maintained and recovered.
- End-user significant status
- The following status are end-user significant status for nodes and users.
  - Conversation
  - STSN
  - Fast Path

These are status that frequently change for a resource, and thus there are performance considerations related to maintaining end-user significant status. The installation can tell IMS how to recover end-user significant status by specifying the level of recovery for each status. Shown for each resource is the level of recovery for each end-user significant status.

## **username**

Specifies either a user structure name or a RACF user ID.

"Attributes" are reserved parameters for the **/DISPLAY USER** command and cannot be used to name users. Any one attribute can be used with the USER keyword. Users are selected for display based on the attribute or attributes specified. The attribute display format is the same as the standard USER display. Attributes usually correspond to the conditions displayed for users.

Following is a list of the attributes that can be specified with the USER keyword:

- ALLOC
- CONVACT
- CONVHLD
- DEADQ
- EXCL
- MFST
- PRST
- RESP
- RESPINP
- STATIC
- STOPPED
- TEST

RESPINP shows users with RESP-INP and RESP-INP-FP status.

## Usage notes

The USER parameter can be generic when the generic parameter specifies users that already exist.

The following information is displayed:

- The USER field shows the user structure name. N/A appears for all user IDs signed on to static nodes.
- The USERID field shows the RACF user ID that was used to sign on to the node. N/A appears if a user structure is not associated with a node. In that case, the user structure exists to hold status or has messages inserted to it. If no messages or status exist, the user structure is deleted at the next checkpoint.
- The node name appears if the user is allocated to a node or signed on to a node.
- The cumulative queue counts for enqueues, dequeues, and number of items still on the queue for the specified users is displayed. The cumulative counts include all LTERMs associated with the specified users, whether the LTERMs are allocated to a node or not.

For non-ISC static users, queue counts are displayed as N/A, since non-ISC static users are not associated with queues.

- STOPPED or ALLOC is displayed to show whether the user LTERMs are assigned to a node (ALLOC) or the user is stopped (STO).

User IDs can only be used as parameters with the **/DISPLAY USER** command and the **/SIGN ON** command. In other commands that support the USER keyword, the user structure name, not the user ID, must be used.

The ALLOC status is followed by the node name (in parentheses) to which the user is allocated or signed on to.

The use of DEADQ with the **/DISPLAY USER** command shows all users that have queues marked as dead letter queues. When all the messages are purged by the **/DEQUEUE** command, the DEADQ status is removed. After all the messages have been purged and the status removed, then the user structure is deleted at the next simple checkpoint.

In a shared-queues environment, use the QCNT keyword to obtain the current message queue counts on the shared queues structure. The local queue counts (ENQCT, DEQCT, and QCT) value that is returned on this command when the QCNT keyword is not specified represents the messages being processed by the IMS system where this command is issued. Do not use local queue counts for queue evaluation purposes.

## Equivalent IMS type-2 commands

The following table shows variations of the **/DISPLAY USER** command and the IMS type-2 commands that perform similar functions.

Table 319. Type-2 equivalents for the **/DISPLAY USER** command

| Task                                     | <b>/DISPLAY USER</b> command               | Similar IMS type-2 command                       |
|--|--|--|
| Displays preset destination.             | <b>/DISPLAY USER</b> <i>user</i>           | QUERY USER SHOW(PRESET)                          |
| Displays node.                           | <b>/DISPLAY USER</b> <i>user</i>           | QUERY USER SHOW(NODE)<br>QUERY USERID SHOW(NODE) |
| Displays status for a particular user.   | <b>/DISPLAY USER</b> <i>user</i>           | QUERY USER SHOW(STATUS)                          |
| Displays user ID.                        | <b>/DISPLAY USER</b> <i>user</i>           | QUERY USER SHOW(USERID)                          |
| Displays status of a particular user ID. | <b>/DISPLAY USER</b> <i>user</i>           | QUERY USERID SHOW(STATUS)                        |
| Displays user.                           | <b>/DISPLAY USER</b> <i>user</i>           | QUERY USERID SHOW(USER)                          |
| Displays autologon parameters.           | <b>/DISPLAY USER</b> <i>user</i> AUTOLOGON | QUERY USER SHOW(AUTOLOGON)                       |

Table 319. Type-2 equivalents for the /DISPLAY USER command (continued)

| Task  | /DISPLAY USER command                                       | Similar IMS type-2 command |
|---|---|----------------------------|
| Displays queue count.   | /DISPLAY USER <i>user</i><br>/DISPLAY USER <i>user</i> QCNT | QUERY USER SHOW(QCNT)      |
| Displays message queue count in the Expedited Message Handler (EMH) queues. | /DISPLAY USER <i>user</i> QCNT EMHQ                         | QUERY USER SHOW(EMHQ)      |
| Displays status recovery information.                                       | /DISPLAY USER <i>user</i> RECOVERY                          | QUERY USER SHOW(RECOVERY)  |
| Displays owner IMSID in RM resource structure.                              | /DISPLAY USER <i>user</i> RECOVERY                          | QUERY USER SHOW(OWNER)     |

### Examples

The following are examples of the /DISPLAY USER command.

#### Example 1 for /DISPLAY USER command

Entry ET:

```
/DISPLAY USER IMSUS01 IMSUS02
```

Response ET:

```
USER      USERID    ENQCT  DEQCT    QCT
IMSUS01   IMSUS01    1      1        0  ALLOC(DTSLU201) CONV-HLD
N/A      IMSUS01    N/A    N/A      N/A  ALLOC(L3270A ) STATIC
N/A      IMSUS02    N/A    N/A      N/A  ALLOC(L3270B ) STATIC
DT327002 IMSUS02    0      0        0  ALLOC(DT327002)
*92350/112229*
```

Entry ET:

```
/DISPLAY USER USER1 USER2 USER3 QCNT
```

Response ET:

```
USERID    USER          GBLQCT
N/A      USER1         25
USER2    USER2A        0
USER2    USER2B        10
USER3    IMSUSR3A      40
*95200/170817*
```

Entry ET:

```
/DISPLAY USER IMSUS01*
```

Response ET:

```
USER      USERID    ENQCT  DEQCT    QCT
IMSUS01C  N/A       0      0        0  STOPPED
IMSUS01D  N/A       0      0        0  STOPPED
IMSUS01   IMSUS01    1      1        0  ALLOC(DTSLU201) CONV-HLD
N/A      IMSUS01    N/A    N/A      N/A  ALLOC(L3270A ) STATIC
*92350/113904*
```

Entry ET:

```
/DISPLAY USER ALL
```

Response ET:

```
USER      USERID  ENQCT DEQCT  QCT
CA13      N/A      0      0      0  STATIC
IMSUS01C  N/A      0      0      0  STOPPED
IMSUS01D  N/A      0      0      0  STOPPED
LU6SPA    N/A      0      0      0  ALLOC(LU6NDPF )  STATIC
LU6SPB    N/A      0      0      0  STATIC
DT327002 IMSUS02  0      0      0  ALLOC(DT327002)
IMSUS03   IMSUS03  0      0      0  ALLOC(DTSLU601)
IMSUS01   IMSUS01  1      1      0  ALLOC(DTSLU201)  CONV-HLD
IMSUS05   N/A      0      0      0  STOPPED
N/A       IMSUS02  N/A    N/A    N/A  ALLOC(L3270B )  STATIC
N/A       IMSUS01  N/A    N/A    N/A  ALLOC(L3270A )  STATIC
N/A       IMSUS04  N/A    N/A    N/A  ALLOC(L3270C )  STATIC
*92350/114845*
```

### Example 2 for /DISPLAY USER command

Entry ET:

```
/DISPLAY USER ABC100 EMHQ QCNT
```

One user is on the queue.

Response ET:

```
14.42.46      57/DIS USER ABC100 QCNT EMHQ.
14.42.46      IEE600I REPLY TO 57 IS;/DIS USER ABC100 QCNT EMHQ.
14.42.46      JOB00110 DFS000I      USER          GBLQCT      IMS1
14.42.46      JOB00110 DFS000I      ABC100          0          IMS1
14.42.46      JOB00110 DFS000I      *98203/144246*  IMS1
```

### Example 3 for /DISPLAY USER command

Entry ET:

```
/DISPLAY USER IMSUS01 IMSUS02 IMSUS03 AUTOLOGON.
```

Response ET:

```
USER      NODE     MODE     DESC     ID
IMSUS01   N/A      N/A      N/A      N/A
IMSUS02   N/A      N/A      N/A      N/A
IMSUS03   N/A      N/A      N/A      N/A
*99243/082505*
```

Entry ET:

```
/CHANGE USER IMSUS01 AUTOLOGON DT327001 MODE LU032NT4.
```

Response ET:

```
DFS058I CHANGE COMMAND COMPLETED
```

Entry ET:

```
/CHANGE USER IMSUS02 AUTOLOGON DTSLU601 MODE LU6NEGPS ID IMSID2.
```

Response ET:

```
DFS058I CHANGE COMMAND COMPLETED
```

Entry ET:

```
/CHANGE USER IMSUS03 AUTOLOGON DT327001 LOGOND DFS3270 MODE LU032NT4.
```

Response ET:

```
DFS058I CHANGE COMMAND COMPLETED
```

Entry ET:

```
/DISPLAY USER IMSUS01 IMSUS02 IMSUS03 AUTOLOGON.
```

Response ET:

```
USER      NODE      MODE      DESC      ID
IMSUS01   DT327001  LU032NT4  N/A       N/A
IMSUS02   DTSLU601  LU6NEGPS  N/A       IMSID2
IMSUS03   DT327001  LU032NT4  DFS3270   N/A
*99243/083309*
```

#### **Example 4 for /DISPLAY USER RECOVERY command**

Entry ET:

```
/DISPLAY USER IMSUS* IMSUS03 LU6SPG RECOVERY
```

Response ET:

```
USER OWNER SRM CONV STSN FPATH
IMSUS05 IMSA GLOBAL Y Y Y
IMSUS01 IMSA LOCAL Y Y Y
IMSUS03 IMSB GLOBAL Y N N
LU6SPG IMSA LOCAL Y Y Y
*99240/134730*
```

#### **Related reference**

[“Status and attributes for the /DISPLAY command” on page 501](#)

A list of the attributes and status shown in the **/DISPLAY** command are described in the following table.

[QUERY USER command \(Commands\)](#)

[QUERY USERID command \(Commands\)](#)



## Chapter 28. /END command

The **/END** command terminates all special operating modes established through the prior entry of an **/EXCLUSIVE**, **/TEST**, or **/LOOPTEST** command.

**/END NODE | USER** does not reset TEST mode. Only the same terminal that is in TEST mode can reset the TEST mode (using **/END** without the NODE or USER keywords).

Subsections:

- [“Environment” on page 723](#)
- [“Syntax” on page 723](#)
- [“Keywords” on page 723](#)
- [“Usage notes” on page 724](#)
- [“Example” on page 724](#)

### Environment

The following table lists the environments (DB/DC, DBCTL, and DCCTL) in which you can use the command and keywords.

Table 320. Valid environments for the /END command and keywords

| Command / Keywords | DB/DC | DBCTL | DCCTL |
|--------------------|-------|-------|-------|
| <b>/END</b>        | X     |       | X     |
| LINE               | X     |       | X     |
| NODE               | X     |       | X     |
| PTERM              | X     |       | X     |
| USER               | X     |       | X     |

### Syntax

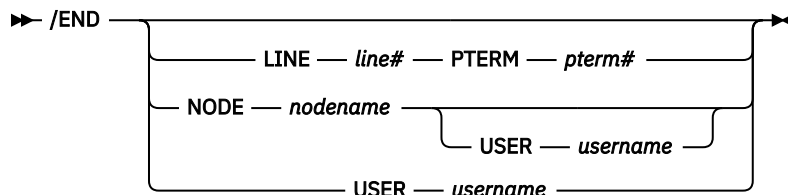

### Keywords

The following keywords are valid for the **/END** command:

#### LINE

Specifies the communication line for which special operating modes are terminated.

#### NODE

Specifies the VTAM node for which special operating modes are terminated.

**/END NODE** is not valid for ISC nodes with users or nodes that were dynamically created. **/END NODE USER** only applies to ISC sessions and affects the half-session allocated to username.

**Restrictions for using NODE and USER parameters together:**

- Commands with the NODE USER keyword pair are valid only if:
  - The USER is signed on to the NODE
  - In an ISC environment, the USER is allocated to the NODE
  - The nodes and users already exist
- **/END NODE USER** commands are valid for ISC and non-ISC nodes and users.

**USER**

Without the NODE keyword, USER specifies the dynamic user for which special operating modes are terminated. The named user must exist in IMS, must be dynamic, and must not be signed on to a node. When **/END USER** is issued against a temporary user, which was created solely to retain status that is now reset, the temporary user is deleted at the next simple checkpoint.

**Usage notes**

The **/END NODE** command applies to dynamic nodes in addition to static nodes because MFSTEST mode is associated with dynamic nodes as well as dynamic users. The **/END NODE** command and the **/END NODE USER** command reset MFSTEST mode at the node level. The **/END USER** command resets MFSTEST at the user level. The **/END** command with no keywords resets MFSTEST at the node level for static terminals (they have no user level) and at the user level for dynamic terminals. The **/END NODE USER** command supports static and dynamic ISC sessions. When the **/END NODE** command or the **/END NODE USER** command is used for a dynamic node, only MFSTEST is reset. Exclusive mode can only be reset for a dynamic resource with the **/END USER** command. If global resource information is kept in Resource Manager, MFSTEST mode is reset globally and locally. If global resource information is not kept in Resource Manager, MFSTEST mode is reset locally.

The **/END** command with no keywords operates on the entering terminal with a signed on user. The **/END** command with no keywords is not supported through the OM API in an IMSplex.

This command can be issued to an IMSplex using the Batch SPOC utility.

**Example**

Entry ET:

```
/END
```

Response ET:

```
DFS058I  END COMMAND COMPLETED
```

Explanation: All modes that previously existed are ended.



## Chapter 29. /ERESTART command

Use the **/ERESTART** command, which is a multisegment command, to restart IMS any time the system was not terminated with an orderly **/CHECKPOINT** shutdown.

Three conditions that result in the need for an emergency restart are:

- Abnormal termination of IMS
- Abnormal termination of z/OS
- Forced termination of IMS by using the z/OS MODIFY command

Subsections:

- [“Environment” on page 725](#)
- [“Syntax” on page 726](#)
- [“Keywords” on page 727](#)
- [“Usage notes” on page 731](#)
- [“Examples” on page 732](#)

### Environment

The following table lists the environments (DB/DC, DBCTL, and DCCTL) in which you can use the command and keywords.

| Command / Keywords | DB/DC | DBCTL | DCCTL |
|--------------------|-------|-------|-------|
| <b>/ERESTART</b>   | X     | X     | X     |
| BUILDQ             | X     |       | X     |
| CHECKPOINT         | X     | X     | X     |
| CMDAUTH            | X     |       | X     |
| CMDAUTHE           | X     |       | X     |
| COLDBASE           | X     | X     |       |
| COLDCOMM           | X     |       | X     |
| COLDSYS            | X     | X     | X     |
| FORMAT             | X     | X     | X     |
| MULTSIGN           | X     |       | X     |
| NOBMP              | X     | X     | X     |
| NOCMDAUTH          | X     |       | X     |
| NOCMDAUTHE         | X     |       | X     |
| NOTRANAUTH         | X     |       | X     |
| NOUSER             | X     |       | X     |
| OPTION             | X     | X     | X     |
| OVERRIDE           | X     | X     | X     |
| SNGLSIGN           | X     |       | X     |

Table 321. Valid environments for the /ERESTART command and keywords (continued)

| Command / Keywords | DB/DC | DBCTL | DCCTL |
|--------------------|-------|-------|-------|
| TRANAUTH           | X     |       | X     |
| USER               | X     |       | X     |

## Syntax

### Restart of IMS following loss of virtual storage only

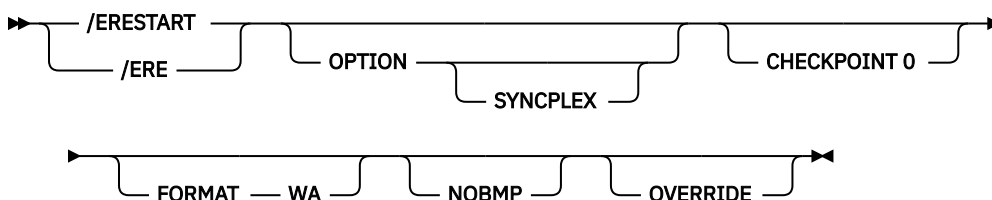

### Restart of IMS following loss of virtual storage and message queue data set integrity

The message queues have not been dumped to the system log since the most recent cold start.

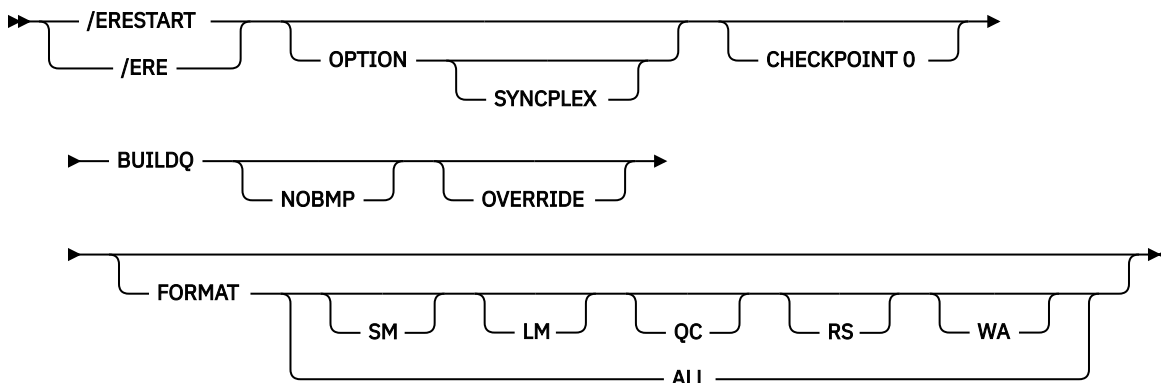

### Restart of IMS following /ERESTART failure of the database component

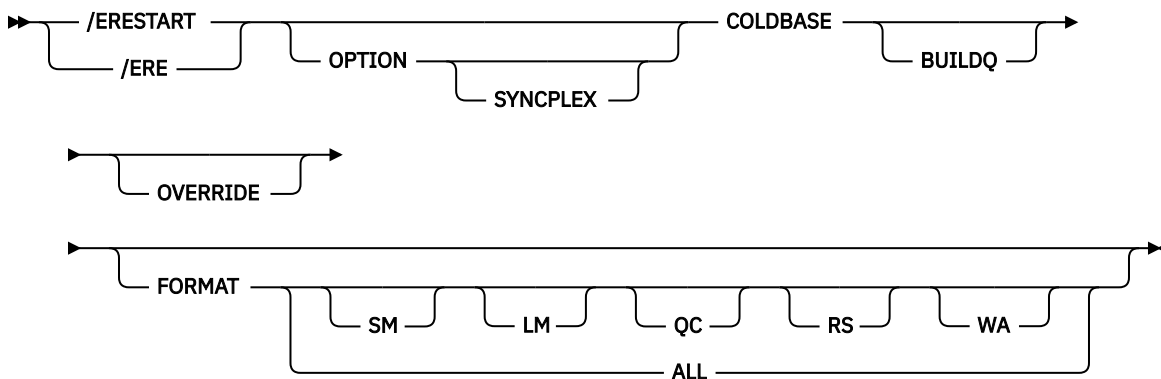

### Restart of IMS following /ERESTART failure of communication component

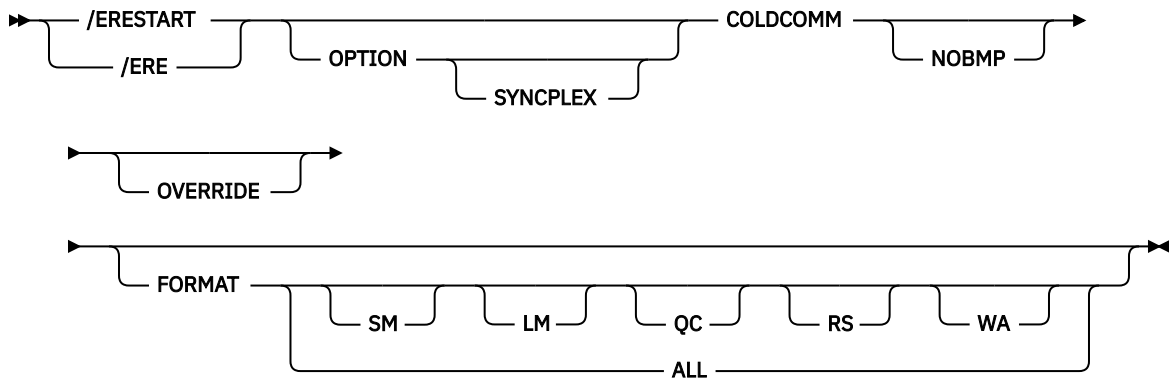

**Restart of IMS following /ERESTART failure of both the database and communication components**

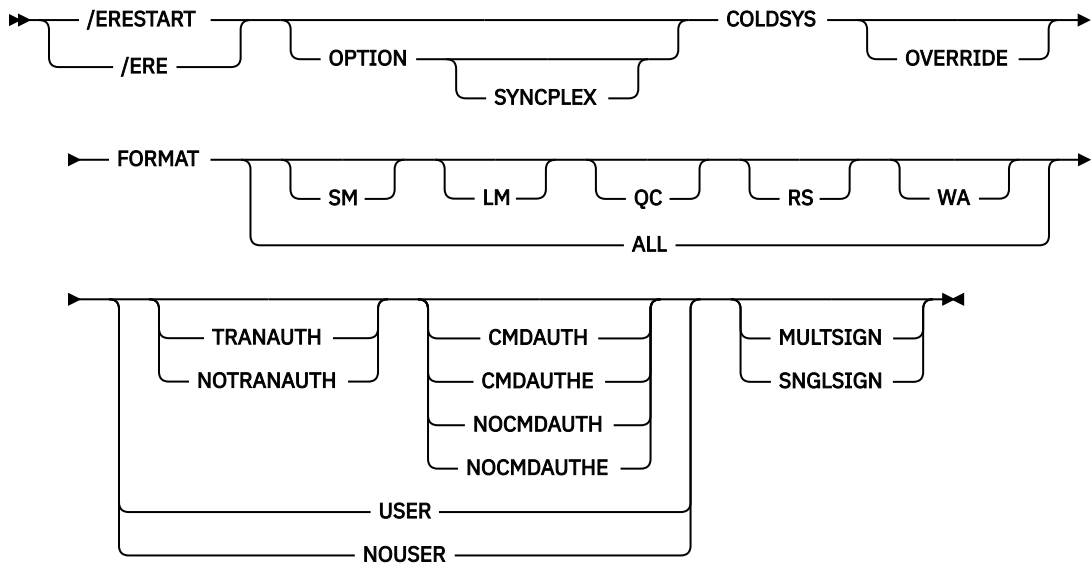

**Keywords**

The following keywords are valid for the `/ERESTART` command:

**BUILDQ**

Is required for any restart from a failure in which message queue data set integrity was lost. When a checkpoint other than checkpoint 0 is specified, the checkpoint must be one at which the message queues were dumped to the system log. Message queue data set integrity has been lost if one or more of the data sets have been reallocated or reformatted. If a checkpoint is not specified, IMS selects the appropriate checkpoint from which to start.

If an `/ERESTART BUILDQ` command fails, and then you issue the `/ERESTART CHECKPOINT 0`, `/ERESTART COLDCOMM`, or `/ERESTART COLDSYS` command, messages in local queues are lost. However, IMS Message Requirer (MRQ) can be used to recover local message queues.

In a shared-queues environment, the `BUILDQ` keyword is ignored because the message queue data sets are not used.

**CHECKPOINT**

`CHECKPOINT` is an optional keyword that identifies whether the restart should use the latest cold start system checkpoint that was taken by the IMS subsystem. If you do not specify this keyword, IMS determines the correct system checkpoint to use. If you do specify this keyword, you can specify only `CHECKPOINT 0` to use the latest cold start system checkpoint.

## **CMDAUTH**

Specifies that both signon (user identification verification) and command authorization for static and ETO terminals are in effect at the end of the emergency restart. (Command authorization is same as specifying RCF=S on the startup parameter.)

To specify CMDAUTH, you must specify RCF=A|Y|T|C|S as an initialization EXEC parameter.

## **CMDAUTHE**

Specifies that command authorization for ETO terminals (same as RCF=S on the startup parameter) is in effect at the end of the emergency restart. CMDAUTHE also resets command authorization for static terminals, if it was set.

To specify CMDAUTHE, you must specify RCF=A|Y|T|C|S as an initialization EXEC parameter.

## **COLDBASE**

Indicates a cold start of the database component, while performing an emergency restart of the communications component.

- If this keyword is used, you are responsible for the recovery of the databases. The Fast Path areas will not be redone and no backouts of inflight DL/I databases will be performed. If in-doubts exist, a batch backout run with the cold start option will backout inflight DL/I data. This will place both DL/I and Fast Path data in the aborted state.
- If this keyword is not used, the database component will be warm started.

If IMS is enabled to use the repository, IMS calls Resource Manager (RM) at the end of COLDBASE processing to read the change list, if one exists, for the IMS. The IMS change list is maintained by RM and is built if the **IMPORT** command with the SCOPE(ALL) keyword is issued while the IMS system is down. IMS imports the stored resource definitions from the repository for the resources and descriptors in the change list. The resources and descriptors in the change list are quiesced and not available for use until the stored resource definitions are imported from the repository. The change list for the IMS is deleted at the end of COLDBASE processing.

## **COLDCOMM**

Indicates a cold start of the data communication component, while an emergency restart of the database component is being performed. This includes recovering Fast Path DEDBs, reloading MSDBs, backing out inflight changes to DL/I databases, and maintaining all existing indoubt data. COLDCOMM is used to get the DC network reinstated as soon as possible while databases are being recovered. As a result of COLDCOMM, all of the messages on the local message queue will be lost; inflight messages in shared queues are moved to the cold queue for later recovery. If this keyword is not used, the data communication component will be restarted.

If IMS is enabled to use the repository, IMS calls RM at the end of COLDCOMM processing to read the change list, if one exists, for the IMS. The IMS change list is maintained by RM and is built if the **IMPORT** command with the SCOPE(ALL) keyword is issued while the IMS is down. IMS imports the stored resource definitions from the repository for the resources and descriptors in the change list. The resources and descriptors in the change list are quiesced and not available for use until the stored resource definitions are imported from the repository. The change list for the IMS is deleted at the end of COLDCOMM processing.

## **COLDSYS**

Indicates a cold start of both the database and the data communication components. An **/ERE COLDSYS** command differs from a **/NRE CHECKPOINT 0** command in function, but the COLDSYS keyword is equivalent to, and replaces, the **/NRE CHECKPOINT 0 DETACH** command. The COLDSYS keyword is the newer syntax.

The use of the COLDSYS keyword causes the release of database authorizations for DBCTL SHARECTL (full DBRC data sharing) and releases any locks held by the subsystem in IRLM. This is the required form of cold start following a failure when using DBRC SHARECTL.

The SGN=, TRN=, and RCF= startup parameters can be overridden by the **/ERESTART COLDSYS** command using the keywords shown in the following table. This table lists the keywords and the startup parameters that those keywords can override and a brief description.

Table 322. Security keywords and their startup parameter equivalents

| <b>Keyword</b> “1” on page 729 | <b>Description</b>  | <b>Startup parameter</b>   |
|--------------------------------|---|--|
| CMDAUTH                        | RACF command authorization on static and ETO terminals only                                   | RCF=S  |
| CMDAUTHE                       | RACF command authorization on ETO terminals only  | RCF=C  |
| MULTSIGN                       | Permits multiple signons for each user ID   | SGN=M  |
| NOCMDAUTH                      | Resets the command authorization on static and ETO terminals                                  | Not RCF=S  |
| NOCMDAUTHE                     | Resets the command authorization on ETO terminals only  | Not RCF=C  |
| NOTRANAUTH                     | Resets the transaction authorization.   | Not TRN=F or Y   |
| NOUSER                         | Resets user identification verification, transaction authorization, and command authorization | Not SGN=F or Y<br>(G or Z becomes M)<br>Not TRN=F or Y<br>Not RCF=C or S |
| SNGLSIGN                       | Permits a single signon for each user ID  | SGN=F and Y<br>Not SGN=M<br>(G or Z becomes F or Y)                      |
| TRANAUTH                       | Transaction authorization   | TRN=F or Y   |
| USER                           | Sets user identification verification   | SGN=Y  |

**Note:**

1. Valid only with the **/ERESTART COLDSYS** command.

If AUTOIMPORT=REPO or AUTOIMPORT=AUTO is specified and IMS is enabled to use the repository, the stored resource definitions are read from the repository during COLDSYS processing. The IMS change list is not processed during **/ERE COLDSYS** processing because all the resource definitions are imported as part of COLDSYS processing. If one exists, the change list in RM for the IMS being restarted with COLDSYS is deleted.

**FORMAT**

Specifies which queues or data sets should be formatted as part of the restart process when:

- A message queue or data set I/O error occurs.
- The size of a message queue or data set is to be changed.
- A message queue or data set is to be reallocated.
- Allocation of the WADS changes.

When queues or data sets must be formatted as part of the restart process, specify one or more of the following:

**SM**

Short-message queue

**LM**

Long-message queue

**QC**

Control record data set (QBLKs)

**RS**

Restart data set

**WA**

Write ahead data set

**ALL**

All message queues (SM and LM) and data sets (QC, WA, and RS). For DBCTL, this supports RS and WA only.

Any combination of SM, LM, QC, WA, MD, and RS can be specified; for example, FORMAT LM RS. When you specify ALL, do not specify SM, LM, QC, WA, MD, or RS.

In a shared-queues environment, the LM, SM, and QC parameters are ignored because the message queue data sets are not used. If you specify ALL, IMS does not attempt to format the message queue data sets.

The following table shows the environments in which the parameters are valid.

*Table 323. /ERESTART FORMAT command parameter environments*

| Parameter | DB/DC | DBCTL | DCCTL |
|-----------|-------|-------|-------|
| SM        | X     |       | X     |
| LM        | X     |       | X     |
| QC        | X     |       | X     |
| RS        | X     | X     | X     |
| WA        | X     | X     | X     |
| MD        | X     |       | X     |
| ALL       | X     | X     | X     |

If the WADS must be reformatted during emergency restart, the ALL parameter can be used. IMS first closes the OLDS from the WADS and then reformats the WADS. If you generally use the ALL parameter during restart, do not be concerned that the WADS will not be available to close the OLDS.

**MULTSIGN**

Permits multiple signons for each user ID.

In an IMSplex with Resource Manager and a resource structure, if MULTSIGN conflicts with the single user signon definition for the IMSplex, a warning message is issued.

**NOBMP**

Specifies no backout of BMP updates occurs and all affected databases and programs are stopped.

If NOBMP is not specified, all updates made subsequent to the last commit point invoked by the active BMP programs are backed out of the database as part of the restart process.

NOBMP is ignored if no BMP programs were active at the time of the system failure.

**NOCMDAUTH**

Resets command authorization on static and ETO terminals.

**NOCMDAUTHE**

Resets command authorization for static and ETO terminals. The command authorization is reset for static terminals because the command authorization for static terminals cannot exist without the command authorization for ETO terminals.

**NOTRANAUTH**

Turns off transaction authorization. NOTRANAUTH is not the opposite of TRANAUTH. TRANAUTH sets transaction authorization and also turns on signon (user identification verification).

If you specify NOTRANAUTH, it will be rejected with an error message if TRN=F was specified as a JCL EXEC parameter.

## NOUSER

Specifies that none of the following is in effect at the end of the emergency restart:

- Transaction authorization
- User identification verification
- Command authorization

## OPTION

Specifies parameters that are in effect for the execution of the restart process.

The valid parameters for this keyword are as follows:

### SYNCPLEX

Synchronize the startup of IMS systems after a multi-IMS failure. The option SYNCPLEX is entered on all the IMS systems that are to be synchronized. At the end of the restart process, the write to operator with replay (WTOR) message, DFS3067A, is issued. Once all of the IMS Systems are at this WTOR, they are now synchronized and can resume normal processing. The operator replies to the WTOR on each IMS and normal processing resumes

## OVERRIDE

Is required only to restart the system after failure of power, machine, z/OS, or DBRC where IMS abnormal termination was unable to mark the DBRC subsystem record in RECON as abnormally terminated. IMS emergency restart will abort with message DFS0618A when DBRC indicates that the subsystem is currently active and that neither the OVERRIDE keyword nor the BACKUP keyword is present on the **/ERESTART** command. If there is any doubt about the status of an IMS system at restart time, the OVERRIDE keyword should not be used.



**Attention:** Use of the OVERRIDE keyword on a currently running IMS system can lead to database and system integrity problems.

## SNGLSIGN

Permits a single signon for each user ID.

In an IMSplex with Resource Manager and a resource structure, if SNGLSIGN conflicts with the single user signon definition for the IMSplex, a warning message is issued.

## TRANAUTH

Specifies both transaction authorization and user identification verification, with or without RACF.

To specify TRANAUTH, you must specify RCF=A|Y|T|C|S as an initialization EXEC parameter.

## USER

Specifies user identification verification. User identification verification means that signon is required by static terminals. This keyword has no effect on ETO terminals because they are always required to sign on. User identification verification can be forced on by TRANAUTH or CMDAUTH.

To specify USER, you must specify RCF=A|Y|T|C|S as an initialization EXEC parameter.

## Usage notes

This command can be issued to an IMSplex by using the Batch SPOC utility.

For an **/ERESTART** command restart, the base security definition is created:

- From the IMS system definition and the EXECUTE parameter specifications, when the COLDSYS keyword is specified.
- From the IMS checkpoint data, when the COLDSYS keyword is not specified.

To override the security definitions, specify the COLDSYS keyword and the security keywords on the COLDSYS keyword.

The format for **/ERESTART** depends on the type of system failure that is associated with the termination and whether the message queues have been dumped to the system log since the most recent cold start.

All **/ERESTART** formats require an EOM indication to denote end-of-message; an EOS indication must be included for all segments that precede the last segment.

With Fast Path, the **/ERESTART** command loads the latest MSDB checkpoint data set and applies all MSDB changes up to the latest complete commit point. **/ERESTART** also ensures that DEDB updates created between the restart checkpoint and the latest complete commit point are applied. If the DEDB updates are not applied, they are queued for output. Output messages not acknowledged or not transmitted are also queued for output.

When IMS is initialized, the system parameters that are used for this initialization can come from the IMS system generation, from a PROCLIB member, or from EXEC statements that can override both the defaults and the PROCLIB members. Therefore, message DFS1929I is displayed showing the system parameters used for this particular initialization. The system parameters are also written to the job log.

When the **/ERESTART** command is issued without any keywords or with the COLDBASE or COLDCOMM keyword, IMS processes the system log during emergency restart processing to build runtime resource definitions from the log. The stored resource definitions from the RDDS or the IMSRSC repository are not used during emergency restart processing to build runtime resource definitions.

If IMS is enabled to use the repository, IMS calls Resource Manager (RM) at the end of emergency restart to read the change list for the IMS. The IMS change list is maintained by RM and is built if the **IMPORT** command with the SCOPE(ALL) keyword is issued while the IMS is down.

If a change list exists for the IMS that is being restarted, the database, program, transaction, and routing code resources and descriptors in the IMS change list and that apply to the IMS environment are quiesced and are not available for use until the stored resource definitions are imported from the repository.

After the IMS log is processed, IMS imports the stored resource definitions from the repository for the database, program, transaction, and routing code resources and descriptors in the IMS change list. It then applies the changes to the runtime resource and descriptor definitions in the IMS.

For the resources or descriptors that are in the IMS change list and that do not exist in IMS, the runtime resource definitions are created from the stored resource definitions in the repository. For the resource or descriptors that exist in IMS, the runtime resource definitions are updated with the stored resource definitions from the repository. The change list for the IMS is deleted at the end of the emergency restart.

## Examples

The following are examples of the **/ERESTART** command:

### **Example 1 for /ERESTART command**

All system data sets are intact.

Entry ET:

```
/ERESTART.
```

Response ET:

```
DFS058I (time stamp) ERESTART COMMAND IN PROGRESS
DFS680I USING CHKPT 85200/123456
DFS994I *CHKPT 85201/110117**SIMPLE*
```

Explanation: The restart is being performed from checkpoint 85200/123456, which was selected by IMS. If IMS contained active BMPs when the system failed, checkpoint 85200/123456 is the checkpoint that allows backout of all updates made by each active BMP since its latest system checkpoint. A simple checkpoint is written on the system log. The checkpoint number is 85201/110117.

### **Example 2 for /ERESTART command**

Message queues are in error.

Entry ET:

```
/ERESTART BUILDQ.
```



Response ET:

```
DFS058I (time stamp) ERESTART COMMAND IN PROGRESS
DFS680I USING CHKPT 85119/074811
DFS994I *CHKPT *85120/192021**SIMPLE*
```

Explanation: IMS is restarted at 192021 (time) on 85120 (\* \* date) from the most recent DUMPQ or SNAPQ checkpoint, 85119/074811. A simple checkpoint is written on the system log. The checkpoint number is 85120/192021.

The message queues from checkpoint 85119/074811 are loaded.

If BMP programs were active when the system failed, all updates invoked by the BMP programs are backed out.

### **Example 3 for /ERESTART command**

Small and large message queues were reallocated. The message queues have been dumped at least once since the most recent cold start.

Entry ET:

```
/ERESTART BUILDQ FORMAT SM LM.
```

Response ET:

```
DFS058I (time stamp) ERESTART COMMAND IN PROGRESS
DFS680I USING CHKPT 85201/070348
DFS994I *CHKPT *85204/010203**SIMPLE*
```

Explanation: IMS is restarted at 010203 (time) on 85204 (Julian date). A simple checkpoint was written on the system log. The checkpoint number is 85204/010203.

The large and small message queue data sets are reformatted.

The message queues are loaded from checkpoint 85201/070348.

If BMP programs were active when the system failed, all updates invoked by the BMP programs are backed out.

### **Example 4 for /ERESTART command**

Message queues in error or data sets reallocated and the message queues have not been dumped since the most recent cold start.

Entry ET:

```
/ERESTART BUILDQ FORMAT ALL NOBMP.
```

Response ET:

```
DFS058I (time stamp) ERESTART COMMAND IN PROGRESS
DFS680I USING CHKPT 85045/112140
DFS994I *CHKPT 85121/235959**SIMPLE*
```

Explanation: IMS is restarted at 235959 (time) on 85121 (Julian date) from the checkpoint taken during cold start 85045/112140. A simple checkpoint is written on the system log. The checkpoint number is 85121/235959.

All message queues and data sets are reformatted.

The message queues from the system log were loaded.

BMP programs that were active when the system failed are stopped, as are the databases updated by them.

### **Related concepts**

[Synchronizing IMS restart after a multiple IMS system failure \(System Administration\)](#)

Shutting down an IMS system that uses dynamic resource definition (Operations and Automation)

**Related reference**

“Commands recovered during emergency restart” on page 26

Certain commands that successfully alter IMS resources are written to the system log as X'02' or X'22' log records and are reprocessed during emergency restart.

“How to enter IMS commands” on page 2

These topics describe how to enter various types of IMS commands.

“/CHECKPOINT command” on page 153

The **/CHECKPOINT** command records control and status information about the system log.

## Chapter 30. /EXCLUSIVE command

Use the **/EXCLUSIVE** command to put a terminal into exclusive mode. This command, without keywords, is valid from a terminal with a signed on user.

The LINE PTERM and NODE keywords are only valid for output-only terminals. For a dynamically created user, the exclusive mode status is remembered across signons.

Subsections:

- [“Environment” on page 735](#)
- [“Syntax” on page 735](#)
- [“Keywords” on page 735](#)
- [“Usage notes” on page 736](#)
- [“Examples” on page 736](#)

### Environment

The following table lists the environments (DB/DC, DBCTL, and DCCTL) in which you can use the command and keywords.

Table 324. Valid environments for the /EXCLUSIVE command and keywords

| Command / Keywords | DB/DC | DBCTL | DCCTL |
|--------------------|-------|-------|-------|
| <b>/EXCLUSIVE</b>  | X     |       | X     |
| LINE               | X     |       | X     |
| NODE               | X     |       | X     |
| PTERM              | X     |       | X     |
| USER               | X     |       | X     |

### Syntax

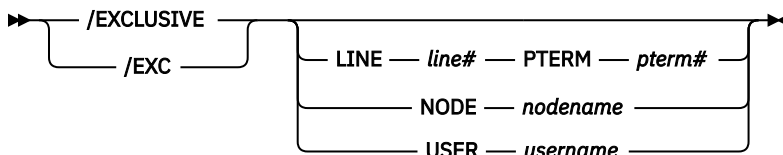

### Keywords

The following keywords are valid for the **/EXCLUSIVE** command:

#### LINE PTERM

Specifies the communication line to be put into exclusive mode. The **/DISPLAY LINE line# PTERM pterm#** command identifies a terminal in exclusive mode.

#### NODE

Specifies that the static VTAM node be put into exclusive mode. This command is not valid for nodes that were dynamically created.

## USER

Specifies that the dynamic user be put into exclusive mode. If the user does not exist in IMS, it and its associated LTERMs will be created to remember the exclusive status. If **/EXCLUSIVE USER** is issued against an existing user, the user must be dynamic.

## Usage notes

Exclusive mode restricts the output received by the terminal affected:

- A regular input/output terminal in exclusive mode only receives messages transmitted in response to transactions entered from that physical terminal.
- An output-only terminal in exclusive mode receives messages transmitted in response to transactions entered into its associated input logical terminals.

Except for an IMS system message responding to an error condition, all other output for a terminal in exclusive mode remains queued for later transmission. The queued output is transmitted after exclusive mode is reset with the **/END** command or a **/START** command.

In an IMSplex, if global resource information is kept in Resource Manager, the **/EXCLUSIVE** command sets a global exclusive status for the resource. If global resource information is not kept in Resource Manager, the **/EXCLUSIVE** command sets the status.

This command can be issued to an IMSplex using the Batch SPOC utility.

The **/END** command is used to get a terminal out of exclusive mode.

## Examples

The following are examples of the **/EXCLUSIVE** command:

### **Example 1 for /EXCLUSIVE command**

Entry ET:

```
/EXCLUSIVE
```

Response ET:

```
DFS058I EXCLUSIVE COMMAND COMPLETED
```

Explanation: No messages are sent to this terminal other than application program output resulting directly from transaction input.

### **Example 2 for /EXCLUSIVE command**

Entry ET:

```
/EXCLUSIVE USER alpha
```

Response ET:

```
DFS058I EXCLUSIVE COMMAND COMPLETED
```

# Chapter 31. /EXIT command

Use the **/EXIT** command to end conversations between users and application programs.

The conversation can be either active or in hold status at the time **/EXIT** is entered. Depending upon the conversational processing options selected for the IMS system, the application program might or might not be notified of the conversation termination.

Subsections:

- [“Environment” on page 737](#)
- [“Syntax” on page 737](#)
- [“Keywords” on page 738](#)
- [“Usage notes” on page 738](#)
- [“Examples” on page 739](#)

## Environment

The following table lists the environments (DB/DC, DBCTL, and DCCTL) in which you can use the command and keywords.

*Table 325. Valid environments for the /EXIT command and keywords*

| Command / Keywords | DB/DC | DBCTL | DCCTL |
|--------------------|-------|-------|-------|
| <b>/EXIT</b>       | X     |       | X     |
| CONVERSATION       | X     |       | X     |
| LINE               | X     |       | X     |
| LUNAME             | X     |       | X     |
| NODE               | X     |       | X     |
| PTERM              | X     |       | X     |
| TMEMBER TPIPE      | X     |       | X     |
| USER               | X     |       | X     |

## Syntax

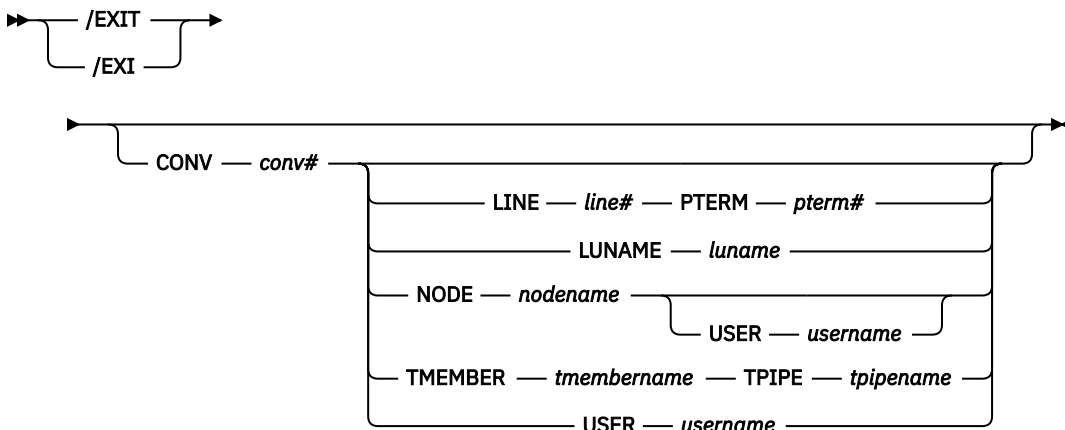

## Keywords

The following keywords are valid for the **/EXIT** command:

### CONVERSATION

Terminates the specified conversation. The conversation is terminated whether it was active or held. The conversation identifier (conv#) must be specified as a 4-digit number, including leading zeros.

### LINE PTERM

Terminates the conversation on the physical terminal specified, regardless of whether the conversation was active or held. The line specified must be in stopped and idle status.

### LUNAME

Terminates the IMS conversation and the APPC conversation on the specified luname. In an IMSplex environment, **/EXIT LUNAME** needs to be issued on the IMS that owns the conversation. Within an IMS system, the conversation ID is unique.

### NODE

Terminates the conversation on the node specified, regardless of whether the conversation was active or held. The node specified must be stopped or idle. This form of the command does not support dynamic nodes or LU 6.2 nodes defined with users.

The **NODE USER** combination applies only to the specified half-session of the ISC parallel session node allocated to **USER**. The half-session must have been stopped and idled. The command must be issued from a terminal or node other than the one in the conversation.

#### Restrictions for using **NODE** and **USER** parameters together:

- Commands with the **NODE USER** keyword pair are valid only if:
  - The **USER** is signed on to the **NODE**
  - In an ISC environment, the **USER** is allocated to the **NODE**
  - The nodes and users already exist
- **/EXIT (CONV) NODE USER** commands are valid for ISC, LUP, and 3600 nodes only.

### TMEMBER TPIPE

Terminates the IMS conversation on the specified *tmembername tpipe*name. In an IMSplex environment, **/EXIT TMEMBER TPIPE** must be issued on the IMS that owns the conversation. Within an IMS system, the conversation ID is unique.

### USER

Terminates the conversation associated with the specified user. The user must not be signed on to a node. The user must be dynamic.

## Usage notes

Transactions that are queued for processing when the **/EXIT** command is issued are discarded. If a transaction is being processed or was sent to a remote system for processing when **/EXIT** is issued, the command is still processed; however, the conversation will be terminated, but the conversational transaction will still be issued. When the conversational response is received, the Conversational Abnormal Termination exit (DFSCONE0) is called, and the response message is queued to the response terminal.

The **/EXIT** command with no keywords can only be used if the conversation is active.

If global resource information is kept in Resource Manager (RM), **/EXIT NODE** or **/EXIT USER** terminates the conversation in RM. If global resource information is not kept in RM, **/EXIT NODE** or **/EXIT USER** terminates a conversation on the IMS where the **/EXIT** command is entered or routed to by the OM SPOC.

This command can be issued to an IMSplex using the Batch SPOC utility.

**/EXIT** is not valid from an LU 6.2 device or OTMA device. DEALLOCATE the APPC conversation after receiving all output from an iteration. When the **/EXIT** command specifies only the CONVERSATION keyword, the command can be entered only from the terminal that owns the conversation.

### Examples

The following are examples of the **/EXIT** command:

#### **Example 1 for /EXIT command**

Entry ET:

```
/EXIT
```

Response ET:

```
DFS058I  EXIT COMMAND COMPLETED
```

Explanation: The active and not held conversation associated with the entering terminal is terminated.

#### **Example 2 for /EXIT command**

Entry ET:

```
/EXIT
```

Response ET:

```
DFS576I  EXIT COMPLETED, TRANSACTION DISCARDED
```

Explanation: **/EXIT** processing found the conversational transaction enqueued for an application or transmission across an MSC link, but it has not yet been scheduled for processing. The transaction has been discarded.

#### **Example 3 for /EXIT command**

Entry ET:

```
/EXIT
```

Response ET:

```
DFS577I  EXIT COMPLETED, TRANSACTION STILL ACTIVE
```

Explanation: **/EXIT** processing found the conversational transaction had been or is in the process of being transmitted across an MSC link.

#### **Example 4 for /EXIT command**

Entry ET:

```
/EXIT CONVERSATION 0001
```

Response ET:

```
DFS058I  EXIT COMMAND COMPLETED
```

Explanation: The active or held conversation (0001) is terminated if the terminal is in conversation.

#### **Example 5 for /EXIT command**

Entry ET:

```
/EXIT CONVERSATION 0001 LINE 10 PTERM 2
```

Response ET:

```
DFS058I  EXIT COMMAND COMPLETED
```

Explanation: Used from another PTERM or master terminal when a PTERM in conversation is "locked," waiting for a response. **/EXIT CONVERSATION** should be used before a **/START LINE** command that resets all conversations active on the line.



## Chapter 32. EXPORT command

Use the **EXPORT** command to export runtime resource and descriptor definitions from the online IMS system to a resource definition data set (RDDS) or the IMSRSC repository as stored resource definitions.

The resource and descriptor definitions can then be:

- Added to IMS dynamically through the **IMPORT** command
- Imported from an RDDS during an IMS cold start
- Imported from the repository during an IMS cold start, or an IMS warm start or emergency restart for changed list processing

The resource and descriptor definitions are read from the repository during processing of the **QUERY xxx SHOW(DEFN)** command.

Subsections:

- [“Environment” on page 741](#)
- [“Syntax” on page 741](#)
- [“Keywords” on page 743](#)
- [“Usage notes” on page 749](#)
- [“Output fields” on page 751](#)
- [“Return, reason, and completion codes” on page 752](#)
- [“Examples” on page 757](#)

### Environment

The following table lists the environments (DB/DC, DBCTL, and DCCTL) in which you can use the command and keywords.

*Table 326. Valid environments for the EXPORT command and keywords*

| Command / Keywords | DB/DC | DBCTL | DCCTL |
|--------------------|-------|-------|-------|
| <b>EXPORT</b>      | X     | X     | X     |
| DEFN               | X     | X     | X     |
| ENDTIME            | X     | X     | X     |
| NAME               | X     | X     | X     |
| OPTION             | X     | X     | X     |
| RDDSDSN            | X     | X     | X     |
| SET                | X     | X     | X     |
| STARTTIME          | X     | X     | X     |
| TARGET             | X     | X     | X     |
| TYPE               | X     | X     | X     |

### Syntax

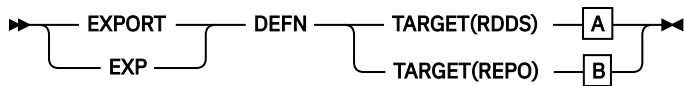

**A**

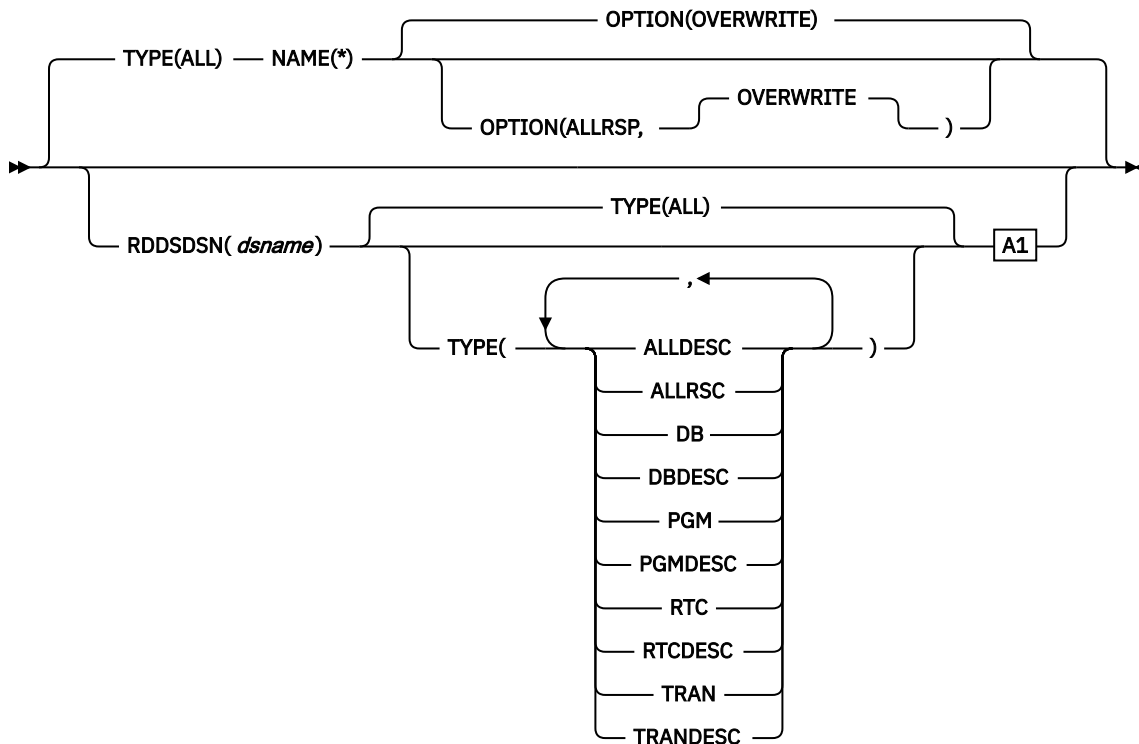

**A1**

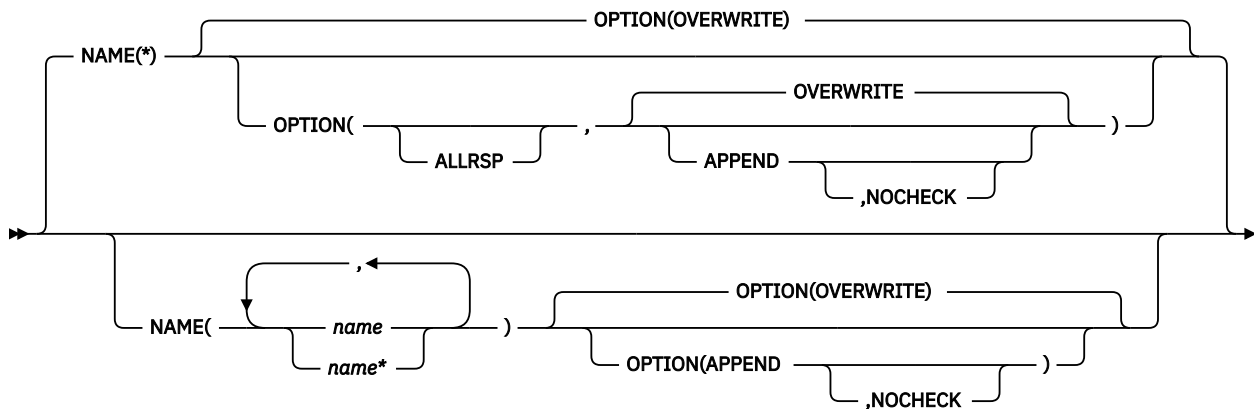

**B**

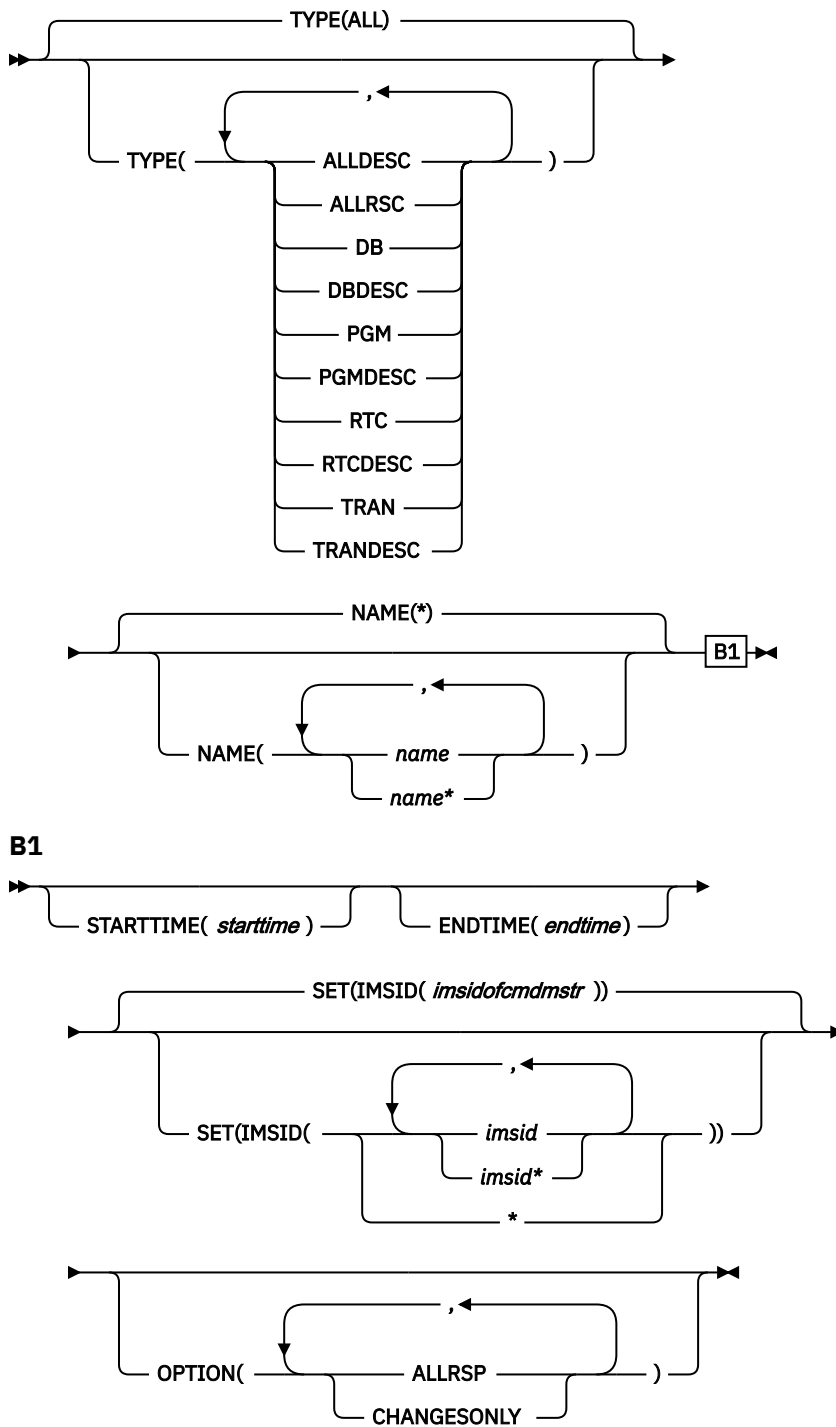

## Keywords

The following keywords are valid for the **EXPORT** command:

### DEFN

Specifies that resource and descriptor definitions are to be exported.

### ENDTIME

Specifies the end time until which new and modified runtime resource definitions are to be gathered to be exported to the repository. ENDTIME is the local time and is specified in the following format:

```
yyyy.ddd hh:mm:ss.ms.th
```

where *yyyy.ddd* is required, and the rest of the parameters (*hh*, *mm*, *ss*, *ms*, and *th*) are optional and default to 0.

When the ENDTIME keyword is specified, all the resource definitions that have either a create time stamp or an update time stamp less than the ENDTIME value specified are exported to the repository. If the TYPE, NAME, or STARTTIME keyword is specified with ENDTIME, the resource definitions that match all the specified keywords are exported to the repository.

If ENDTIME is not specified, all the resources that are found that match the STARTTIME, NAME, and TYPE keywords are exported to the repository.

**Note:** Consideration must be taken in specifying the ENDTIME value when there is a change in time for the Daylight Saving Time.

### **NAME()**

Specifies the 1-8 character name of a resource or descriptor. Wildcards can be specified in the name. The name is a repeatable parameter. If the NAME parameter specified is a specific name or a wildcard, command responses are returned for all the resource names that are processed. NAME is an optional parameter, and if not specified, it defaults to NAME(\*). For NAME(\*), command responses are returned only for the resource and descriptor names that resulted in an error. OPTION(ALLRSP) can be specified with NAME(\*) to obtain the command responses for all of the resource and descriptor names that are processed.

### **OPTION()**

Specifies additional functions to be performed along with the command.

#### **ALLRSP**

Indicates that response lines are to be returned for all resources and descriptors that are processed by the command. If NAME(\*) is specified, the default action is to return response lines only for the resources and descriptors that resulted in an error. OPTION(ALLRSP) can be used with NAME(\*) to request response lines for all resources and descriptors processed by the command. If a name value other than NAME(\*) is specified, the default action is to return a response line for all resources and descriptors processed by the command. If OPTION(ALLRSP) is specified with a name value other than NAME(\*), the ALLRSP parameter is ignored.

For HALDB databases, only the definition of the HALDB master database is exported. HALDB partition definitions are not exported, because the partition definitions are maintained in the RECON data set. OPTION(ALLRSP) does not include the partitions definitions in the output and therefore does not flag them with a nonzero completion code.

When coding the Destination Creation exit routine (DFSINSX0), the user can indicate whether the definitions for transaction and program resources created by the exit should be exported. Transaction and program resource definitions that are not exported are not included in the OPTION(ALLRSP) output.

IMS resources such as the Fast Path utility (DBF#FPU0) and the IMS defined descriptors (DBFDSRT1, DFSDSDB1, DFSDSPG1, and DFSDSTR1) are not exported. OPTION(ALLRSP) does not include these resources and descriptors in the output and therefore does not flag them with a nonzero completion code.

#### **APPEND**

Indicates that the resource and descriptor definitions are to be appended to the end of the specified RDDS data set. If OPTION(NOCHECK) is not specified, validity checking is done to ensure that the IMS performing the export is the same IMS that previously exported definitions to the RDDS. The APPEND option is valid only when exporting to a non-system RDDS.

APPEND is mutually exclusive with OVERWRITE. If APPEND results in multiple definitions for the same resource in the RDDS, IMS uses the definition that was exported most recently when the definitions are imported.

## **CHANGESONLY**

Specifies that the runtime resource definitions with changes (resources and descriptors that are created or updated) since the last successful export are to be exported to be hardened in the repository. `OPTION(CHANGESONLY)` is supported only for `TARGET(REPO)`.

The list of the names of the resources that are to be exported to the repository can also be provided on the command input. If a list of resource names is specified, the resources that have changes (creates or updates) since the last successful export are exported to the repository. If the specified resource does not have any changes, a completion code is returned for that resource. The export is completed for all other resources that have changes.

A list of the names of the resources that are exported to the repository is returned on the command response.

When `NAME(*)` is specified with `OPTION(CHANGESONLY)`, it is treated as if `OPTION(ALLRSP)` was specified; all resource names that are exported to the repository are returned on the command response. If no resource names have any changes when `NAME(*)` is specified, no resources are exported and the command results in an error reason code.

## **NOCHECK**

Indicates that no ID checking is to be done when definitions are appended to an RDDS. If `OPTION(NOCHECK)` is specified, the IMS performing the export can be a different IMS than the one that performed the previous export. The `NOCHECK` option is valid only when exporting to a non-system RDDS. `NOCHECK` is mutually exclusive with `OVERWRITE` and can be specified only if `APPEND` is specified.

## **OVERWRITE**

Indicates that the resource and descriptor definitions are to overwrite any existing definitions in the RDDS. `APPEND` is mutually exclusive with `OVERWRITE`. `OVERWRITE` is the default and the only valid option when exporting to a system RDDS.

## **RDDSDSN(*dsname*)**

An optional keyword that is used to specify the name of a non-system RDDS to which resource and descriptor definitions are to be exported. When the `RDDSDSN()` keyword is omitted from the **EXPORT** command, the definitions are written to the system RDDS that contains the oldest data. The data set name specified in the `RDDSDSN()` keyword cannot be the name of any of the system RDDSs defined in the `DYNAMIC_RESOURCES` section of the `DFSDFxxx PROCLIB` member. If a set of system data sets is not defined in the `DYNAMIC_RESOURCES` section of the `DFSDFxxx PROCLIB` member, the `RDDSDSN()` keyword is required on the **EXPORT** command.

If using the `RDDSDSN()` keyword to specify a specific data set, care should be taken when routing the **EXPORT** command by using Operations Manager (OM) routing. If the command is routed to multiple IMS systems in the IMSplex, only the IMS selected as the command master will process the command.

The data set specified for the `RDDSDSN()` keyword must be a physical sequential (`DSORG=PS`) BSAM data set. The data set must exist and be cataloged. When creating and allocating the RDDS data set, ensure that an end-of-file (EOF) mark is placed at the beginning of the data set. Failure to do so can produce unpredictable results. To place an EOF mark at the beginning of the data set, use program `IEBGENER`. The sample job skeleton `DFSRDDAL`, which is in the `IMS.SDFSSLIB` data set, can be used for this step. An alternative method of allocating the RDDS data sets is to use the `ALLOCATE` function of ISPF utilities. The `ALLOCATE` function places an EOF mark correctly at the beginning of the data set. Do not use program `IEFBR14` to allocate the RDDS data sets, because `IEFBR14` does not place an EOF mark at the beginning of the data set.

IMS allocates the RDDS with `DISP=OLD` during the export process. If you attempt to allocate a new data set by using JCL in one step of a job and then try to issue the **EXPORT** command by using the batch `SPOC` in another step of the same job, the batch export will fail with return code 10 (environment error) and reason code 4118 (data set allocate error), followed by message `DFS2503W` with error reason code 210 (data set is allocated to another job). This is because IMS cannot obtain an exclusive enqueue on the newly allocated RDDS.

Generation data group (GDG) data sets are not fully supported for RDDs. Relative generation numbers cannot be used when specifying an RDD name. For example, if you specify `RDDSDSN(IMS.EXP.GDG(0))` or `RDDSDSN(IMS.EXP.GDG(+1))`, the **EXPORT** command will fail with message DFS2503W and error reason code 35C (invalid parm specified in text unit). Specifying the absolute generation number for a GDG data set does work. For example, `RDDSDSN(IMS.EXP.GDG.G0001V00)` can be specified.

## SET

Specifies what actions are to be set.

### IMSID

Specifies one or more IMS IDs whose IMS resource lists are to be updated by the **EXPORT** command.

An IMS resource list is a list of resource or descriptor names that is used to define the resources for an IMS system. IMS resource lists reside in the repository and are used during IMS cold start to identify all the resource and descriptor definitions that are to be read during the IMS cold start.

For each IMS system defined in the repository, one IMS resource list is created for each resource type defined for the IMS:

- Databases
- Database descriptors
- Programs
- Program descriptors
- Routing codes
- Routing code descriptors
- Transactions
- Transaction descriptors

When a resource definition is written to the repository for an IMS, the resource name is added to the appropriate IMS resource list if it does not already exist in the list. If an IMS resource list does not exist for that IMS and resource type, an IMS resource list for that IMS and resource type is created, and the resource name is added to it.

For example, if the **EXPORT DEFN TARGET(REPO) NAME(TRANABC) TYPE(TRAN) SET(IMSID(IMS1,IMS2,IMS3))** command is issued, the IMS resource lists for each IMS ID specified (IMS1, IMS2, and IMS3) might be updated along with the resource definition for transaction TRANABC. If TRANABC is not already in the transaction resource list for an IMS system, it is added to the list. If no transactions have been defined for the IMS, the IMS resource list for transactions is created for the IMS, and TRANABC is added to the list. If TRANABC is already in the resource list for the IMS, the resource list is not updated.

The IMSID value specified on the **EXPORT** command identifies the IMS resource lists that are to be created or updated when a stored resource definition is created or updated in the repository.

The IMSID value can be a specific IMS ID, a list of specific IMS IDs, a wildcard name of `*`, or a wildcard name with `*` or `%`. The IMSID must be a 1- to 4-alphanumeric character value, and can include any of the following special characters: `# $ % * @`

If the IMSID specified is a wildcard name other than `*`, the IMS resource lists for those IMS systems whose names match the IMSID wildcard name will be updated. The list of IMS IDs whose IMS resource lists are updated is returned in command output. If the repository is empty and there are no resource definitions in the repository, the **EXPORT** command fails.

`IMSID(*)` indicates that the IMS resource lists for all IMS systems defined in the repository are to be updated with the resource names of the exported definitions. In other words, the resource definitions being exported will belong to all IMS systems that currently have resource definitions in the repository. If the repository is empty and there are no resource definitions in the repository, the **EXPORT** command fails.

The IMSID value can also be specified as a list of one or more IMS IDs of the IMS systems for which the resource lists must be updated. When one or more IMS IDs are specified, only the IMS resource lists for the specified IMS IDs are updated in the repository. If the IMS resource lists for the IMS IDs specified do not exist, the IMS resource lists are created.

The IMSID value that is specified does not have to belong to an active IMS in the IMSplex. The IMSID of an IMS that is yet to be started can be specified.

When exporting definitions for a new IMS, you must issue the **EXPORT** command with a specific IMSID value to create resource definitions in the repository. When a specific IMSID value is specified, the IMS resource list is created for IMS even if the IMS is currently not registered to RM. If the resource definitions are created for an IMS in error, you can use the **DELETE DEFN** command with the **FOR(imsid)** option to delete the resource definitions and the IMS resource lists.

If **SET(IMSID())** is not specified, the IMSID value defaults to the IMS ID of the command master IMS. An IMS resource list is created for the command master IMS if one does not exist. You are required to route or direct the command to each IMS by using the **ROUTE** keyword.

### STARTTIME

Specifies the start time from which all new and modified runtime resource definitions are to be gathered and exported to the repository. **STARTTIME** is the local time and is specified in the following format:

```
yyyy.ddd hh:mm:ss.ms.th
```

where *yyyy.ddd* is required, and the rest of the parameters (*hh*, *mm*, *ss*, *ms*, and *th*) are optional and default to 0.

When the **STARTTIME** keyword is specified, all the resource definitions that have either a create time stamp or an update time stamp greater than or equal to the **STARTTIME** specified will be exported to the repository. If the **ENDTIME**, **TYPE**, or **NAME** keyword is specified with **STARTTIME**, the resource definitions that match all the specified keywords are exported to the repository.

The list of the resource names that are exported to the repository is provided on the command output.

When **NAME(\*)** is specified with the **STARTTIME** keyword with or without the **ENDTIME** keyword, it is treated as if **OPTION(ALLRSP)** was specified, and all resource names that are exported to the repository are returned on the command response. If no resource names have any changes when **NAME(\*)** is specified, no resources are exported, and the command results in an error reason code.

**Consideration for daylight saving time:** Consideration must be taken in specifying the **STARTTIME** parameter when there is a change in time for the Daylight Saving Time in regard to the current local time. For the spring time adjustment, time is adjusted forward by one hour at 2:00 a.m. If you want to export all the resources that have changed since 12:30 a.m. (before the time change), you would have to specify **STARTTIME** of 1:30 a.m. on the command because 12:30 a.m. (before time change) corresponds to 1:30 a.m. (after time change). For the fall time adjustment, time is adjusted backward by one hour at 2:00 a.m. If you want to export all resources that have changed since 12:30 a.m. (before the change), you would have to enter a **STARTTIME** of 11:30 p.m. on the prior day because 12:30 a.m. (before time change) corresponds to 11:30 p.m. (after time change).

### TARGET()

Specifies where resource and descriptor definitions are to be exported.

#### RDDS

Specifies that resource and descriptor definitions are to be exported to an RDDS. If the **RDDSDSN()** keyword is not used to specify the name of a non-system RDDS, the system RDDS with the oldest data is used.

Even when IMS is enabled to use the repository, you can use the **EXPORT DEFN TARGET(RDDS)** command to export runtime resource and descriptor definitions to a system RDDS or a non-system RDDS if the RDDS is defined.

## REPO

Indicates that the runtime resource definitions of the resource names specified on the NAME keyword are to be exported to the IMSRSC repository. Only the resource definitions of the resource names that match the NAME keyword are created or updated in the repository. If the resource definition does not exist in the repository, it is created. If the resource definition exists in the repository, it is replaced. TARGET(REPO) is valid only when IMS is enabled to use the repository.

A repository can maintain resource and descriptor definitions for up to 64 IMS systems in an IMSplex.

All resource definitions are exported to the repository as a single unit of work (UOW). If any resource results in an error being written to the repository, no resource definitions are written.

The system-defined descriptors are not exported to the repository. The HALDB partition databases are not exported to the repository when TYPE(ALL) or TYPE(DB) is specified.

If any RM CSLRPUPD request errors are returned for the **EXPORT** command, you must check to see if there are any in-doubts. If the error is before the UOW is committed, all updates to the repository are backed out. If the failure is during UOW commit and if the repository primary data set is updated, the UOW is committed. You must issue the **QUERY xxx SHOW(DEFN)** commands to verify if the changes are hardened in the repository, and if not, reissue the **EXPORT** command.

The **EXPORT DEFN TARGET(REPO)** command is processed only by the IMS that has been selected as the command master. All other IMS systems that receive the command return an IRSN\_NOTMSTR return and reason code. In a cloned IMS configuration, the **EXPORT** command can be issued with SET(IMSID(\*)) so that the exported definitions are written to the repository and all the IMS resource lists in the repository are updated. If a resource name does not exist in an IMS resource list and SET(IMSID(\*)) is specified, the resource name is added to the IMS resource list. In a non-cloned IMS configuration, issue the **EXPORT** command to each IMS individually so that each IMS acts as the command master and exports its own resource and descriptor definitions. In this case, the **EXPORT** command with the default SET(IMSID()) keyword can be issued and the same command will be routed to each IMS in the IMSplex.

When an FP(E) transaction is created in the repository by the **EXPORT DEFN** command, the routing code for the FP(E) transaction will also be created in the repository by RM.

### Recommendations:

- Avoid issuing the **EXPORT DEFN** command with TARGET(REPO) NAME(\*) TYPE(ALL) during peak hours because exporting all the resource definitions to the repository can incur a larger than normal command response time. However, while the resource definitions are being written to the repository, there is no impact to other work in IMS.
- In order to avoid incurring performance overhead of accessing resources in the repository that have not been updated, export to the repository only those resources that have been updated. If you do not know the names of the resources that have been updated recently and need to be exported, you can issue the **EXPORT** command with the STARTTIME keyword so that you can export all resources that have been updated since a specific time.

During the **EXPORT DEFN TARGET(REPO)** command processing, resource validation is performed in RM as follows:

- When a new transaction or routing code definition is added to the repository, resource validation checking is done to ensure that a definition for the associated program either exists in the repository or is being added to the repository with the **EXPORT** command.
- When an existing program, transaction, or routing code definition is updated in the repository, resource validation checking is done to ensure that the attributes being updated do not conflict with the attributes of any associated resource definitions. For example, if the transaction is modified to FP(E), a check is done to ensure that the associated program is defined as FP exclusive.



## **TYPE()**

Specifies the type of resource or descriptor definitions to export.

### **ALL**

Specifies that all definitions for all resource and descriptor types (DB, DBDESC, PGM, PGMDESC, RTC, RTCDESC, TRAN, and TRANDESC) are to be exported.

### **ALLDDESC**

Specifies that all definitions for all descriptor types (DBDESC, PGMDESC, RTCDESC, and TRANDESC) are to be exported. TYPE(ALLDDESC) is not valid when exporting to a system RDDS or when exporting from an IMS that does not have DRD enabled.

### **ALLRSC**

Specifies that all definitions for all resource types (DB, PGM, RTC, and TRAN) are to be exported. TYPE(ALLRSC) is not valid when exporting to a system RDDS.

### **DB**

Specifies that one or more database definitions are to be exported. TYPE(DB) is not valid when exporting to a system RDDS. If TYPE(DB) is specified on a DCCTL system, completion code 10 ("NO RESOURCES FOUND") is returned.

### **DBDESC**

Specifies that one or more database descriptor definitions are to be exported. TYPE(DBDESC) is not valid when exporting to a system RDDS or when exporting from an IMS that does not have DRD enabled. If TYPE(DBDESC) is specified on a DCCTL system, completion code 10 ("NO RESOURCES FOUND") is returned.

### **PGM**

Specifies that one or more program definitions are to be exported. TYPE(PGM) is not valid when exporting to a system RDDS.

### **PGMDESC**

Specifies that one or more program descriptor definitions are to be exported. TYPE(PGMDESC) is not valid when exporting to a system RDDS or when exporting from an IMS that does not have DRD enabled.

### **RTC**

Specifies that one or more routing code definitions are to be exported. TYPE(RTC) is not valid when exporting to a system RDDS. If TYPE(RTC) is specified on a DBCTL system, completion code 10 ("NO RESOURCES FOUND") is returned.

### **RTCDESC**

Specifies that one or more routing code descriptor definitions are to be exported. TYPE(RTCDESC) is not valid when exporting to a system RDDS or when exporting from an IMS that does not have DRD enabled. If TYPE(RTCDESC) is specified on a DBCTL system, completion code 10 ("NO RESOURCES FOUND") is returned.

### **TRAN**

Specifies that one or more transaction definitions are to be exported. TYPE(TRAN) is not valid when exporting to a system RDDS. If TYPE(TRAN) is specified on a DBCTL system, completion code 10 ("NO RESOURCES FOUND") is returned.

### **TRANDESC**

Specifies that one or more transaction descriptor definitions are to be exported. TYPE(TRANDESC) is not valid when exporting to a system RDDS or when exporting from an IMS that does not have DRD enabled. If TYPE(TRANDESC) is specified on a DBCTL system, completion code 10 ("NO RESOURCES FOUND") is returned.

## **Usage notes**

The **EXPORT** command can be issued through TSO SPOC, IBM Management Console for IMS and DB2 for z/OS, the Manage Resources options in the IMS Applications menu, or other user-written programs that issue commands through OM API. These commands can also be issued to an IMSplex by using the Batch SPOC utility.

**Important:** Commands such as **CREATE**, **DELETE**, **EXPORT**, **IMPORT**, and **UPDATE**, which affect the definitional attributes of resources and descriptors, are not allowed while the **EXPORT** command is in progress.

The **EXPORT DEFN TARGET (RDDS)** command writes resource and descriptor definitions either to the data set specified by the **RDDSDSN()** keyword or, if the **RDDSDSN()** keyword is omitted, to the system RDDS containing the oldest data. A system RDDS is one of the RDDS data sets defined with the **RDDSDSN=** parameter in the **DYNAMIC\_RESOURCES** section of the **DFSDFxxx PROCLIB** member. A system RDDS contains all of the resource and descriptor definitions for a single IMS. If using automatic import or automatic export, each IMS must have its own set of system RDDS data sets. When exporting to a system RDDS, all of the IMS resource and descriptor definitions must be exported. When exporting to a non-system RDDS, all or some of the IMS resource and descriptor definitions can be exported.

The **EXPORT DEFN TARGET (REPO)** command writes resource and descriptor definitions to the IMSRSC repository. The repository contains all of the resource and descriptor definitions for all IMS systems in the IMSplex that share the repository. When exporting to the repository, all or some of the IMS resource and descriptor definitions can be exported. During export to the repository, you can specify, by using the **SET(IMSID())** keyword, a list of the IMS systems in the IMSplex to which the resource definitions must be defined. The specified resource definitions and the corresponding IMS resource lists in the repository are either updated or created. For more information about IMS resource lists, see the description for the **SET(IMSID())** keyword.

The **EXPORT DEFN TARGET (REPO)** command does not delete resource definitions from the repository. To delete resource definitions from the repository, issue the **DELETE DEFN** command.

To check the contents of the repository, issue the **QUERY DB | DBDESC | PGM | PGMDESC | RTC | RTCDESC | TRAN | TRANDESC** commands with the **SHOW(DEFN,GLOBAL)**, **SHOW(IMSID)**, or **SHOW(DEFN,IMSID,GLOBAL)** keyword. If the repository is empty and contains no resource definitions, the **QUERY** command fails.

When exporting to a system RDDS, all definitions in the system RDDS are overwritten with the definitions being exported. When exporting to a non-system RDDS, the user has the option of overwriting the existing definitions with the new definitions, or appending the new definitions to the end of the data set. When the **APPEND** option is used, all of the definitions that meet the criteria specified on the **EXPORT** command are exported and appended to the existing definitions in the RDDS. If the export results in multiple definitions for the same resource in the RDDS, the last definition written to the RDDS is the definition used by the **IMPORT** command when creating the runtime resource definition for the resource or descriptor.

Definitions for IMS resources such as the Fast Path utility (**DBF#FPU0**) and the descriptors defined by IMS (**DBFDSRT1**, **DFSDSDB1**, **DFS DSPG1**, and **DFS DSTR1**) cannot be exported to the RDDS or the repository.

The **EXPORT** command is not allowed on an XRF alternate or an FDBR region.

Export to a system RDDS is allowed only in a DRD environment (**DFSDFxxx** or **DFSCGxxx** defined with **MODBLKS=DYN**). Export to a non-system RDDS is allowed in a non-DRD environment (**DFSDFxxx** or **DFSCGxxx** defined with **MODBLKS=OLC**, or **MODBLKS** not defined); however, descriptors do not exist and cannot be exported.

The **EXPORT** command is defined as **ROUTE=ALL** to **OM**. When the **EXPORT** command is issued, **OM** routes the **EXPORT** command to all active IMS systems (or to all IMS systems specified in the **ROUTE** list if the **ROUTE** parameter is specified on the **CSLOMCMO** or **CSLOMI** request) that have registered interest in the command. The **EXPORT** command is processed as follows by the IMS systems that receive the command:

- When exporting to a system RDDS, the **EXPORT** command is processed by all IMS systems that receive the command. Each IMS that receives the command exports its resource and descriptor definitions to its own system RDDS. The system RDDSs are not shared among IMS systems, so all IMS systems that receive the command can process the command simultaneously without data set contention.
- When exporting to a non-system RDDS, the **EXPORT** command is treated as if the command was defined to **OM** as **ROUTE=ANY**. **OM** selects one IMS to be the command master. The command master IMS exports its resource and descriptor definitions to the specified non-system RDDS. All non-master IMS systems that receive the command return without exporting any definitions with an “IMS not master” return and reason code to **OM**. The export to the non-system RDDS is processed by only one IMS to

avoid data set contention and to prevent the resource and descriptor definitions from being overwritten if the RDDS is shared between IMS systems.

- When exporting to the repository, the **EXPORT** command is treated as if the command was defined to OM as ROUTE=ANY. OM selects one IMS to be the command master. The command master IMS exports its resource and descriptor definitions to the repository. All non-master IMS systems that receive the command return without exporting any definitions with an "IMS not master" return and reason code to OM.

If the **EXPORT** command is to be processed by a specific IMS, the **EXPORT** command must be routed to that IMS.

**Recommendation:** When exporting to a non-system RDDS, each IMS should export its definitions to a unique data set. If one RDDS is shared between systems, the resource and descriptor definitions written by one IMS might be overwritten by another IMS.

**Considerations for Fast Path exclusive transactions and their associated routing codes:** When a definition for a Fast Path exclusive transaction is exported to the repository, the definition for the associated routing code is automatically created or updated in the repository if the routing code definition is not exported at the same time.

The export process fails if all of the following conditions are met:

- A Fast Path exclusive transaction definition is exported to the repository without its associated routing code definition
- The transaction definition is being created for the IMS
- A routing code definition with the same name already exists in the repository
- Either the PGM value or the INQ value in the routing code definition is different from the PGM or INQ value in the new transaction definition

If a Fast Path exclusive transaction definition is exported to the repository without its associated routing code definition and a definition for the transaction already exists in the repository for the IMS and either the PGM value or the INQ value is being updated, the PGM value, the INQ value, or both are automatically updated in the associated routing code definition.

If a routing code definition is exported to the repository without an associated transaction definition, the export process fails if the routing code already exists in the repository for the IMS and the routing code definition in the repository is associated with a Fast Path exclusive transaction definition.

## Output fields

When TARGET(RDDS) is specified, message DFS3404I is returned by each IMS that processes the **EXPORT** command. It indicates whether all, some, or none of the specified resource or descriptors were successfully exported. It also contains the name of the data set to which the resource or descriptor definitions were exported. Each DFS3404I message is encapsulated in a single set of <msg> </msg> XML tags.

When TARGET(REPO) is specified, the **EXPORT** command results in message DFS3406I, which indicates that the export to the repository was successful, or DFS3407E, which indicates that the export was not successful. These messages include the repository name and repository type. If the export to the repository is not successful due to a CSLRPUPD error, the DFS3407E message contains the CSLRPUPD request return code and reason code. The CSLRPUPD return and reason codes are described in the CSLRRR macro.

In addition to the message, command response output is also returned in XML tag structure. The following table shows the **EXPORT** response output fields. The columns in the table are as follows:

### Short label

Contains the short label generated in the XML output.

### Long label

Contains the long label generated in the XML output.

**Keyword**

Identifies keyword on the command that caused the field to be generated. The value *error* appears for output fields that are returned only in the case of an error. N/A (not applicable) appears for output fields that are always returned.

**Meaning**

Provides a brief description of the output field.

Table 327. Output fields for the EXPORT command

| Short label | Long label | Keyword      | Meaning  |
|-------------|------------|--------------|--|
| CC          | CC         | N/A          | Completion code.   |
| CCTXT       | CCText     | <i>error</i> | Completion code text that briefly explains the meaning of the nonzero completion code.   |
| ERRT        | ErrorText  | N/A          | The error text that describes the error completion code.   |
| MBR         | MbrName    | N/A          | IMSpIex member that built the output line.   |
| NAME        | Name       | NAME         | The name of the resource or descriptor definition that was created or updated in the repository, or the name of the IMS resource list that was created or updated in the repository. |
| TYPE        | Type       | TYPE         | The resource or descriptor type, which can be DB, DBDESC, PGM, PGMDESC, RTC, RTCDESC, TRAN, or TRANDESC; or LIST for IMS resource lists.   |

**Return, reason, and completion codes**

The following table includes the return and reason codes and a brief explanation of the codes. The return or reason code returned for the command might also indicate an error from a CSL request.

Table 328. Return and reason codes for the EXPORT command

| Return code | Reason code | Meaning  |
|-------------|-------------|--|
| X'00000000' | X'00000000' | Command completed successfully. The command output contains a line for each resource, accompanied by its completion code. If NAME(*) is specified without OPTION(ALLRSP), no output lines are returned. See the completion code table for details. |
| X'00000004' | X'00001000' | The <b>EXPORT</b> command was not processed on the IMS system, because the IMS system is not the command master. No resource information is returned.  |
| X'00000008' | X'0000211F' | Unable to determine the export data set name. The RDDSDSN() keyword was not specified on the command, and there are no system RDDSs defined.   |
| X'00000008' | X'0000213A' | The data set specified for the RDDSDSN() keyword is a system RDDS.   |
| X'00000008' | X'0000213B' | OPTION(OVERWRITE) is mutually exclusive with OPTION(APPEND).   |
| X'00000008' | X'0000213C' | A value other than NAME(*) was specified. NAME(*) is required when exporting to a system RDDS.   |

Table 328. Return and reason codes for the EXPORT command (continued)

| Return code | Reason code | Meaning  |
|-------------|-------------|--|
| X'00000008' | X'0000213D' | A value other than TYPE(ALL) was specified. TYPE(ALL) is required when exporting to a system RDDS.   |
| X'00000008' | X'0000213E' | OPTION(APPEND) is not allowed when exporting to a system RDDS.   |
| X'00000008' | X'0000213F' | OPTION(NOCHECK) can be specified only if OPTION(APPEND) is specified.  |
| X'00000008' | X'00002146' | Invalid STARTTIME value.   |
| X'00000008' | X'00002147' | TARGET(RDDS) and OPTION(CHANGESONLY) conflict.   |
| X'00000008' | X'00002148' | TARGET(RDDS) and SET(IMSID()) conflict.  |
| X'00000008' | X'00002149' | TARGET(RDDS) and STARTTIME conflict.   |
| X'00000008' | X'0000214A' | TARGET(RDDS) and ENDTIME conflict.   |
| X'00000008' | X'0000214B' | TARGET(REPO) and OPTION(APPEND) conflict.  |
| X'00000008' | X'0000214C' | TARGET(REPO) and RDDSDSN conflict.   |
| X'00000008' | X'0000214D' | Either an invalid ENDTIME value was specified or the ENDTIME value specified was less than or equal to the STARTTIME value specified.  |
| X'00000008' | X'0000214F' | RM resource validation error.  |
| X'0000000C' | X'00003000' | Command was successful for some resources but failed for others. The command output contains a line for each resource, accompanied by its completion code. If NAME(*) is specified without OPTION(ALLRSP), output lines are only returned for resources with nonzero completion codes. |
| X'0000000C' | X'00003004' | Command was not successful for any of the resources. The command output contains a line for each resource, accompanied by its completion code. See the completion code table for details.  |
| X'00000010' | X'00004004' | No CQS address space.  |
| X'00000010' | X'0000400C' | Command is not valid on the XRF alternate.   |
| X'00000010' | X'00004018' | No resource structure, or resource structure is not available.   |
| X'00000010' | X'00004100' | Resource structure is full.  |
| X'00000010' | X'00004104' | No RM address space.   |
| X'00000010' | X'00004108' | No SCI address space.  |
| X'00000010' | X'00004114' | Unable to access the RDDS. The RDDS is either a system RDDS or the data set specified with the RDDSDSN() keyword.  |
| X'00000010' | X'00004118' | Unable to allocate the RDDS. The RDDS is either a system RDDS or the data set specified with the RDDSDSN() keyword.  |
| X'00000010' | X'0000411C' | The <b>EXPORT</b> command was issued to append definitions to an RDDS, but the RDDS contains invalid data.   |
| X'00000010' | X'00004120' | Online change phase is in progress.  |

Table 328. Return and reason codes for the EXPORT command (continued)

| Return code | Reason code | Meaning   |
|-------------|-------------|---|
| X'00000010' | X'00004300' | Command is not allowed, because online change for MODBLKS is enabled (DFSDFxxx or DFSCGxxx defined with MODBLKS=OLC, or MODBLKS not defined) and an RDDS was not specified with the RDDSDSN() keyword.  |
| X'00000010' | X'00004302' | The RDDS is full. No more definitions can be written to the RDDS.   |
| X'00000010' | X'0000432C' | Invalid value is specified for the TYPE() keyword. ALLDESC, DBDESC, PGMDESC, RTCDESC and TRANDESC are not allowed if online change for MODBLKS is enabled (DFSDFxxx or DFSCGxxx defined with MODBLKS=OLC, or MODBLKS not defined).  |
| X'00000010' | X'00004330' | None of the system RDDSs defined in the DFSDFxxx PROCLIB member are available for export.   |
| X'00000010' | X'00004334' | The RECFM of the RDDS is not VB.  |
| X'00000010' | X'00004338' | Invalid RDDS block size. The RDDS must be defined with a block size 4096 - 32760.   |
| X'00000010' | X'0000433C' | The RDDS specified with the RDDSDSN() keyword contains definitions written by another IMS. If new definitions are to be appended to the RDDS by a different IMS, OPTION(NOCHECK) must be specified.   |
| X'00000010' | X'00004500' | IMS is not enabled to use the repository.   |
| X'00000010' | X'00004502' | Repository is not available.  |
| X'00000010' | X'00004504' | Repository spare recovery is in progress.   |
| X'00000010' | X'00004505' | No IMS resource list. This return code can be returned if the <b>EXPORT</b> command with SET(IMSID(*)) is issued and the repository is empty. The SET(IMSID(*)) keyword cannot be processed because there are no IMS resource lists in the repository. Issue the <b>EXPORT</b> command again by specifying a list of IMS IDs, or issue the <b>EXPORT</b> command again without SET(IMSID()) so that the command defaults to the command master IMS. |
| X'00000010' | X'00004507' | Repository access denied.   |
| X'00000010' | X'00004508' | Repository maximum put length exceeded.   |
| X'00000010' | X'00004509' | RM data version is lower than the IMS data version.   |
| X'00000010' | X'0000450A' | Repository Server is being shut down.   |
| X'00000010' | X'0000450B' | Repository Server is not available.   |
| X'00000010' | X'0000450C' | Repository Server is busy.  |
| X'00000010' | X'0000450D' | RM failed to define some of the internal fields related to the IMSRSC repository.   |
| X'00000010' | X'0000450E' | An IMSID list is required.  |
| X'00000010' | X'0000450F' | Maximum number of IMSIDs for the repository was reached.  |
| X'00000010' | X'00004510' | IMSID member table changed during command processing.   |

Table 328. Return and reason codes for the EXPORT command (continued)

| Return code | Reason code | Meaning   |
|-------------|-------------|---|
| X'00000014' | X'00005000' | IMODULE GETSTOR error.  |
| X'00000014' | X'0000500C' | AWE could not be obtained.  |
| X'00000014' | X'00005004' | DFSOCMD response buffer could not be obtained.  |
| X'00000014' | X'00005008' | DFSPPOOL storage could not be obtained.   |
| X'00000014' | X'00005010' | Unable to obtain latch.   |
| X'00000014' | X'00005018' | Unable to obtain a 64-bit buffer.   |
| X'00000014' | X'0000501C' | IMODULE GETMAIN error.  |
| X'00000014' | X'00005100' | RM request error.   |
| X'00000014' | X'00005104' | Unexpected CQS error.   |
| X'00000014' | X'00005108' | SCI request error.  |
| X'00000014' | X'00005110' | Repository error.   |
| X'00000014' | X'0000551C' | A request to update the repository was rejected. Either a corrupted resource list was detected, or the update request was rejected to prevent a corruption of the resource list. Contact IBM Software Support. Send in the output from the command in error, a dump of the local RM address space where the command executed or the dump of all RM address spaces in the IMSplex. Also, send a copy of the IMSRSC repository RID and RMD data sets. |
| X'00000014' | X'00005FFF' | The <b>EXPORT</b> command could not be processed because of an internal error.  |

Errors unique to the processing of this command are returned as completion codes. The following table includes an explanation of the completion codes.

Table 329. Completion codes for the EXPORT command

| Completion code | Completion code text     | Meaning  |
|-----------------|--------------------------|--|
| 0               |                          | Command completed successfully for this resource or resource descriptor.   |
| 10              | NO RESOURCES FOUND       | Resource or descriptor was not found, or the wildcard parameter specified does not match any resource or descriptor names.                     |
| 2E              | NOT ALLOWED FOR RESOURCE | Export of resource or descriptor definition is not allowed. The definitions for IMS defined resources and HALDB partitions cannot be exported. |
| 36              | FP=E/FP=N PGM CONFLICT   | The transaction is defined as Fast Path exclusive FP(E), and the program is defined as non-Fast Path FP(N).                                    |
| 39              | FP=E TRAN FOR RTC EXISTS | The routing code definition is being updated, but the routing code is associated with a Fast Path exclusive FP(E) transaction.                 |

Table 329. Completion codes for the EXPORT command (continued)

| Completion code | Completion code text            | Meaning   |
|-----------------|---------------------------------|---|
| 3E              | FP=N/FP=E PGM CONFLICT          | The transaction is defined as non-Fast Path FP(N), and the program is defined as Fast Path exclusive FP(E).   |
| 3F              | FP=P/BMPTYPE=Y CONFLICT         | The transaction is defined as Fast Path potential FP(P), and the program is defined as program type batch BMPTYPE(Y).   |
| 40              | PARLIM/SCHDTYPE=SERIAL CONFLICT | The transaction is defined with a PARLIM value other than 65535, and the program is defined as SCHDTYPE(SERIAL).  |
| 48              | NOT ALLOWED FOR IMS RESOURCE    | Command not allowed for IMS descriptors or IMS resources. DFSDSDB1, DFSDSPG1, DBFDSRT1, and DFSDSTR1 are examples of IMS descriptors. DBF#FPU0 is an example of an IMS resource.  |
| 59              | MSC KEYWORD/FP=E PGM CONFLICT   | The transaction is defined as remote, but the program is defined as Fast Path exclusive.  |
| 5F              | INVALID CHARACTERS IN NAME      | Resource or descriptor name contains an invalid character.  |
| 67              | NO PGM DEFINED                  | No program is defined. A program name is required for non-remote transaction definitions and routing code definitions. This error should not occur if the definition was created by a valid export or by a utility supplied by IBM. |
| 6A              | FP=P/FP=E PGM CONFLICT          | The transaction is defined as Fast Path potential FP(P), and the program is defined as Fast Path exclusive FP(E).   |
| 6D              | INVALID PROGRAM NAME            | The program referenced by the transaction or routing code is not defined in the repository for the IMS or being exported for the IMS. A program definition is required for non-remote transaction and routing code definitions.     |
| 7A              | RTC/FP=N PGM CONFLICT           | The program is defined as non-Fast Path FP(N), and a routing code definition that references the program either exists in the repository or is being exported.  |
| 90              | INTERNAL ERROR                  | Resource or descriptor definition was not exported because of an internal error.  |
| 94              | RM REQUEST ERROR                | An RM request error occurred. The resource definition was not exported.   |
| B5              | ROUTING CODE ALREADY EXISTS     | A routing code with the same name as the transaction already exists in the repository for the IMS, but either the program name or the INQ value is different. The transaction definition cannot be exported for the IMS.            |
| 121             | RESOURCE HAS NO CHANGE          | The resource name specified has no changes since the last export.   |



Table 329. Completion codes for the EXPORT command (continued)

| Completion code | Completion code text        | Meaning   |
|-----------------|-----------------------------|---|
| 149             | STARTTIME/ENDTIME MISMATCH  | The resource name specified does not match the specified STARTTIME or ENDTIME value.  |
| 14D             | INVALID CHARACTERS IN IMSID | The IMSID value contains an invalid character.  |
| 1D0             | NOT DONE DUE TO ERROR       | An error resulted in the command not being processed for the resource name in the response line. The resource name that had the error will show the error that was encountered. All other resource names will have 1D0 completion code because the export is aborted due to one error. All members are exported as a single unit of work. |
| 1D1             | NO REPOSITORY DEFINED       | No repository is defined.   |
| 1D2             | RM VALIDATION ERROR         | RM validation error.  |
| 1D3             | MEMBER NOT FOUND            | The specified resource name is not found.   |
| 1D4             | MEMBER IN USE               | The specified resource name is in use.  |
| 1D5             | NO IMS RESOURCE LIST        | No IMS resource list.   |
| 1D6             | REPOSITORY ERROR            | Repository error.   |
| 1D7             | IMPORT CHANGE LIST ERROR    | Resource or descriptor is in the process of being imported from the change list in the IMSRSC repository, or the import from the change list failed. The resource or descriptor cannot be exported until it is successfully imported.   |

## Examples

The following are examples of the **EXPORT** command:

### Example 1 for EXPORT command

TSO SPOC input:

```
EXPORT DEFN TARGET(RDDS)
```

TSO SPOC output:

```
Log for: EXPORT DEFN TARGET(RDDS)
```

```
IMSpIex . . . . . : PLEX1
Routing . . . . . :
Start time. . . . : 2007.074 12:40:02.30
Stop time . . . . : 2007.074 12:40:03.32
Return code . . . : 00000000
Reason code . . . : 00000000
Reason text . . . :
Command master. . : IMS2
```

```
MbrName Messages
```

```
-----
IMS1 DFS3404I EXPORT COMMAND COMPLETE FOR ALL , DSN=IMSPLEX1.IMS1.RDDS1.DEFN
IMS2 DFS3404I EXPORT COMMAND COMPLETE FOR ALL , DSN=IMSPLEX1.IMS2.RDDS3.DEFN
```

**Explanation:** The **EXPORT** command is routed to two IMS systems: IMS1 and IMS2. Each IMS exports all of its database, program, routing code, and transaction resource and descriptor definitions to its own system RDDS. Because **OPTION(ALLRSP)** is not specified, the list of exported resources is not returned.

**Note:** Each DFS3404I message is encapsulated in a single set of `<msg>` `</msg>` tags and is shown on the same TSO SPOC screen as the return and reason codes. If the message does not fit on one screen, you might have to scroll to the right to view the entire message.

### Example 2 for EXPORT command

TSO SPOC input:

```
EXPORT DEFN TARGET(RDDS) RDDSDSN(IMSPLEX1.IMS2.RDDS.DEFN) OPTION(ALLRSP)
```

TSO SPOC output:

| Name     | Type     | MbrName | CC |
|----------|----------|---------|----|
| DBDFLT   | DBDESC   | IMS2    | 0  |
| DEDBJN01 | DB       | IMS2    | 0  |
| PGMDFLT  | PGMDESC  | IMS2    | 0  |
| CDEBS    | PGM      | IMS2    | 0  |
| RTCDFLT  | RTCDESC  | IMS2    | 0  |
| SMQFP5A  | RTC      | IMS2    | 0  |
| TRANDFLT | TRANDESC | IMS2    | 0  |
| CDEBTRN1 | TRAN     | IMS2    | 0  |

When the PF4 key is pressed, the following is displayed:

```
Log for: EXPORT DEFN TARGET(RDDS) RDDSDSN(IMSPLEX1.IMS2.RDDS.DEFN) OPTION(ALLRSP)

IMSpIex . . . . . : PLEX1
Routing . . . . . :
Start time . . . . : 2007.074 12:40:02.30
Stop time . . . . . : 2007.074 12:40:03.32
Return code . . . . : 00000000
Reason code . . . . : 00000000
Reason text . . . . :
Command master. . . : IMS2

MbrName  Messages
-----
IMS2     DFS3404I EXPORT COMMAND COMPLETE FOR ALL , DSN=IMSPLEX1.IMS2.RDDS.DEFN
```

**Explanation:** The **EXPORT** command is routed to IMS2. IMS2 exports all of its database, program, routing code, and transaction resource and descriptor definitions to RDDS IMSPLEX1.IMS2.RDDS.DEFN. Because **OPTION(ALLRSP)** is specified, the list of exported resources is returned.

### Example 3 for EXPORT command

TSO SPOC input:

```
EXPORT DEFN TARGET(RDDS) TYPE(ALL) NAME(*) OPTION(ALLRSP)
```

TSO SPOC output:

| Name     | Type     | MbrName | CC | CCText |
|----------|----------|---------|----|--------|
| PART     | DB       | IMS2    | 0  |        |
| PARTMAST | DB       | IMS2    | 0  |        |
| PGMD01   | PGM      | IMS2    | 0  |        |
| RTC001   | RTC      | IMS2    | 0  |        |
| TRND01   | TRAN     | IMS2    | 0  |        |
| TRND11   | TRAN     | IMS2    | 0  |        |
| TRND123  | TRAN     | IMS2    | 0  |        |
| TRND01   | TRANDESC | IMS2    | 0  |        |

When the PF4 key is pressed, the following is displayed:

```
Log for: EXPORT DEFN TARGET(RDDS) TYPE(ALL) NAME(*) OPTION(ALLRSP)
```

```

IMSpIex . . . . . : PLEX1
Routing . . . . . :
Start time . . . . : 2007.074 12:40:02.30
Stop time . . . . . : 2007.074 12:40:03.32
Return code . . . . : 0200000C
Reason code . . . . : 00003000
Reason text . . . . : At least one request successful
Command master. . . : IMS2

```

| MbrName          | Return Code | Reason Code                     | Description                    |
|------------------|-------------|---------------------------------|--------------------------------|
| IMS1             | 00000010    | 00004330                        | No system RDDSs are available  |
| MbrName Messages |             |                                 |                                |
| IMS2             | DFS3404I    | EXPORT COMMAND COMPLETE FOR ALL | , DSN=IMSPLEX1.IMS2.RDDS1.DEFN |

**Explanation:** The **EXPORT** command is routed to two IMS systems: IMS1 and IMS2. IMS1 attempts to export its resource and descriptor definitions to a system RDDS, but none of the system RDDSs are available for export. IMS2 successfully exports its resource and descriptor definitions to RDDS IMSPLEX1.IMS2.RDDS1.DEFN.

#### Example 4 for EXPORT command

TSO SPOC input:

```

EXPORT DEFN TARGET(RDDS) TYPE(DB, DBDESC, TRAN, TRANDESC, PGM, PGMDESC)
NAME(PART*, TRND*, PGMD*) RDDSDSN(IMSPLEX1.IMS2.RDDS.DEFN)

```

TSO SPOC output:

| Name     | Type     | MbrName | CC | CCText             |
|----------|----------|---------|----|--------------------|
| PGMD*    |          | IMS2    | 10 | NO RESOURCES FOUND |
| PART     | DB       | IMS2    | 0  |                    |
| PARTMAST | DB       | IMS2    | 0  |                    |
| TRND11   | TRAN     | IMS2    | 0  |                    |
| TRND120  | TRAN     | IMS2    | 0  |                    |
| TRND123  | TRAN     | IMS2    | 0  |                    |
| TRND123  | TRANDESC | IMS2    | 0  |                    |

When the PF4 key is pressed, the following is displayed:

Log for . . : EXPORT DEFN TARGET(RDDS) TYPE(DB, DBDESC, TRAN, ... More:

```

IMSpIex . . . . . : PLEX1
Routing . . . . . :
Start time . . . . : 2011.124 09:36:06.09
Stop time . . . . . : 2011.124 09:36:06.17
Return code . . . . : 0200000C
Reason code . . . . : 0000300C
Reason text . . . . : The command completed with warning(s).
Command master. . . : IMS2

```

| MbrName          | Return Code | Reason Code                       | Reason text                     |
|------------------|-------------|-----------------------------------|---------------------------------|
| IMS2             | 0000000C    | 00003000                          | At least one request successful |
| IMS1             | 00000004    | 00001000                          | IMS not master, cmd ignored     |
| MbrName Messages |             |                                   |                                 |
| IMS2             | DFS3404I    | EXPORT COMMAND COMPLETE FOR SOME, | DSN=IMSPLEX1.IMS2.RDDS.DEFN     |
| IMS1             | DFS3404I    | EXPORT COMMAND COMPLETE FOR NONE, | DSN=IMSPLEX1.IMS2.RDDS.DEFN     |

OM API input:

```

CMD(EXPORT DEFN TARGET(RDDS) TYPE(DB, DBDESC, TRAN, TRANDESC, PGM, PGMDESC)
NAME(PART*, TRND*, PGMD*) RDDSDSN(IMSPLEX1.IMS2.RDDS.DEFN))

```

OM API output:

```

<imsout>
<ctl>
<omname>OM10M </omname>
<omvsn>1.5.0</omvsn>

```

```

<xmlvsn>20 </xmlvsn>
<statime>2011.124 16:36:06.112826</statime>
<stotime>2011.124 16:36:06.171441</stotime>
<staseq>C7B85E23C774F3FA</staseq>
<stoseq>C7B85E23D94B927E</stoseq>
<rqsttkn1>USRT011 10091756</rqsttkn1>
<rc>0200000C</rc>
<rsn>0000300C</rsn>
<rsnmsg>CSLN055I</rsnmsg>
<rsntxt>The command completed with warning(s).</rsntxt>
</ctl>
<cmderr>
<mbr name="IMS2 ">
<typ>IMS </typ>
<styp>DBDC </styp>
<rc>0000000C</rc>
<rsn>00003000</rsn>
<rsntxt>At least one request successful</rsntxt>
</mbr>
<mbr name="IMS1 ">
<typ>IMS </typ>
<styp>DBDC </styp>
<rc>00000004</rc>
<rsn>00001000</rsn>
<rsntxt>IMS not master, cmd ignored</rsntxt>
</mbr>
</cmderr>
<cmd>
<master>IMS2 </master>
<userid>USRT011 </userid>
<verb>EXP </verb>
<kwd>DEFN </kwd>
<input>EXPORT DEFN TARGET(RDDS) TYPE(DB, DBDESC, TRAN, TRANDESC, PGM,
PGMDESC) NAME(PART*, TRND*, PGMD*) RDDS(DSN(IMSPLEX1.IMS2.RDDS.DEFN)
</input>
</cmd>
<cmdrsphdr>
<hdr slbl="NAME" llbl="Name" scope="LCL" sort="a" key="2" scroll="no"
len="8" dtype="CHAR" align="left" />
<hdr slbl="TYPE" llbl="Type" scope="LCL" sort="a" key="1" scroll="no"
len="8" dtype="CHAR" skipb="yes" align="left" />
<hdr slbl="MBR" llbl="MbrName" scope="LCL" sort="a" key="3" scroll="no"
len="8" dtype="CHAR" align="left" />
<hdr slbl="CC" llbl="CC" scope="LCL" sort="n" key="0" scroll="yes"
len="4" dtype="INT" align="right" skipb="no" />
<hdr slbl="CCTXT" llbl="CCText" scope="LCL" sort="n" key="0"
scroll="yes" len="*" dtype="CHAR" skipb="yes" align="left" />
<hdr slbl="ERRT" llbl="ErrorText" scope="LCL" sort="n" key="0"
scroll="yes" len="*" dtype="CHAR" skipb="yes" align="left" />
</cmdrsphdr>
<cmdrspdata>
<rsp>NAME(PART ) TYPE(DB) MBR(IMS2 ) CC( 0) </rsp>
<rsp>NAME(PARTMAST) TYPE(DB) MBR(IMS2 ) CC( 0) </rsp>
<rsp>NAME(TRND11 ) TYPE(TRAN) MBR(IMS2 ) CC( 0) </rsp>
<rsp>NAME(TRND120 ) TYPE(TRAN) MBR(IMS2 ) CC( 0) </rsp>
<rsp>NAME(TRND123 ) TYPE(TRAN) MBR(IMS2 ) CC( 0) </rsp>
<rsp>NAME(TRND123 ) TYPE(TRANDESC) MBR(IMS2 ) CC( 0) </rsp>
<rsp>NAME(PGMD* ) TYPE() MBR(IMS2 ) CC( 10) CCTXT(NO RESOURCES
FOUND) </rsp>
</cmdrspdata>
<msgdata>
<mbr name="IMS2 ">
<msg>DFS3404I EXPORT COMMAND COMPLETE FOR SOME,
DSN=IMSPLEX1.IMS2.RDDS.DEFN </msg>
</mbr>
<mbr name="IMS1 ">
<msg>DFS3404I EXPORT COMMAND COMPLETE FOR NONE,
DSN=IMSPLEX1.IMS2.RDDS.DEFN </msg>
</mbr>
</msgdata>
</imsout>

```

**Explanation:** The **EXPORT** command is routed to two IMS systems: IMS1 and IMS2. Because the data set is a non-system RDDS, only the IMS that is selected as the command master can process the command. OM selects IMS2 as the command master. IMS2 exports a set of resource and descriptor definitions whose names match the PART\* and TRND\* wildcard values. No resources or descriptors were found matching the PGMD\* wildcard value. IMS1 does not process the command because it is not the command master.

### Example 5 for EXPORT command

TSO SPOC input:

```
EXPORT DEFN TARGET(RDDS) TYPE(ALL) NAME(*)
```

TSO SPOC output:

```
Log for . . : EXPORT DEFN TARGET(RDDS) TYPE(ALL) NAME(*)
```

```
IMSpIex . . . . . : PLEX1
Routing . . . . . : IMS1
Start time . . . . : 2011.124 14:22:57.39
Stop time . . . . . : 2011.124 14:22:57.41
Return code . . . . : 0200000C
Reason code . . . . : 00003004
Reason text . . . . : No requests were successful.
Command master . . : IMS1
```

| MbrName | Return Code | Reason Code | Reason text                                 |
|---------|-------------|-------------|---|
| -----   | -----       | -----       | -----                                       |
| IMS1    | 00000008    | 0000211F    | No system RDDSs defined, rddsdsn() required |

OM API input:

```
CMD(EXPORT DEFN TARGET(RDDS) TYPE(ALL) NAME(*)
```

OM API output:

```
<imsout>
<ctl>
<omname>OM10M </omname>
<omvsn>1.5.0</omvsn>
<xmlvsn>20 </xmlvsn>
<statime>2011.124 21:22:57.408936</statime>
<stotime>2011.124 21:22:57.409591</stotime>
<staseq>C7B8A25066BA8BF2</staseq>
<stoseq>C7B8A25066E37072</stoseq>
<rqsttkn1>USRT011 10142257</rqsttkn1>
<rc>0200000C</rc>
<rsn>00003004</rsn>
<rsnmsg>CSLN024I</rsnmsg>
<rsntxt>No requests were successful.</rsntxt>
</ctl>
<cmderr>
<mbr name="IMS1 ">
<typ>IMS </typ>
<styp>DBDC </styp>
<rc>00000008</rc>
<rsn>0000211F</rsn>
<rsntxt>No system RDDSs defined, rddsdsn() required</rsntxt>
</mbr>
</cmderr>
<cmd>
<master>IMS1 </master>
<userid>USRT011 </userid>
<verb>EXP </verb>
<kwd>DEFN </kwd>
<input>EXPORT DEFN TARGET(RDDS) TYPE(ALL) NAME(*) </input>
</cmd>
</imsout>
```

**Explanation:** The **EXPORT** command is sent to IMS1. There are no system RDDSs defined in DFSDfxxx PROCLIB member of IMS1, and the RDDSdsn() keyword was not specified on the **EXPORT** command. The **EXPORT** command cannot be processed.

### Example 6 for EXPORT command

TSO SPOC input:

```
EXPORT DEFN TARGET(REPO) NAME(*) TYPE(ALL) SET(IMSID(*))
```

TSO SPOC output:

```

Log for . . . : EXPORT DEFN TARGET(REPO) NAME(*) TYPE(ALL) SET(I... More: >
IMSpIex . . . . . : PLEX1
Routing . . . . . : IMS1
Start time . . . . : 2011.123 22:16:24.38
Stop time . . . . . : 2011.123 22:16:28.15
Return code . . . . : 00000000
Reason code . . . . : 00000000
Reason text . . . . :
Command master. . . : IMS1

MbrName  Messages
-----
IMS1     DFS3406I EXPORT COMMAND COMPLETE FOR ALL, REPOTYPE=IMSRSC, REPONAME=IMS_REPOS

```

OM API input:

```
CMD(EXPORT DEFN TARGET(REPO) NAME(*) TYPE(ALL) SET(IMSID(*)))
```

OM API output:

```

<imsout>
<ctl>
<omname>OM10M </omname>
<omvsn>1.5.0</omvsn>
<xmlvsn>20 </xmlvsn>
<statime>2011.124 05:16:24.395621</statime>
<stotime>2011.124 05:16:28.150725</stotime>
<staseq>C7B7CA45F4365B32</staseq>
<stoseq>C7B7CA4988FC5C3A</stoseq>
<rqsttkn1>USRT011 10221624</rqsttkn1>
<rc>00000000</rc>
<rsn>00000000</rsn>
</ctl>
<cmd>
<master>IMS1 </master>
<userid>USRT011 </userid>
<verb>EXP </verb>
<kwd>DEFN </kwd>
<input>EXPORT DEFN TARGET(REPO) NAME(*) TYPE(ALL) SET(IMSID(*)) </input>
</cmd>
<msgdata>
<mbr name="IMS1 ">
<msg>DFS3406I EXPORT COMMAND COMPLETE FOR ALL, REPOTYPE=IMSRSC,
  REPONAME=IMS_REPOS </msg>
</mbr>
</msgdata>
</imsout>

```

**Explanation:** All the runtime resource definitions for all the database, transaction, program, routing code resources and descriptors from IMS are exported to the repository as the stored resource definitions for all IMS systems in the IMSplex. The command is processed by the command master IMS, IMS1. The IMS resource lists for all IMS systems defined to use the repository are updated. The IMS resource lists that have been updated are also returned on the command response.

**Example 7 for EXPORT command**

TSO SPOC input:

```
EXPORT DEFN TARGET(REPO) NAME(TRANA, DBA, RTCA, PGMA) TYPE(ALL) SET(IMSID(IMS1, IMS3))
```

TSO SPOC output:

```

Response for: EXPORT DEFN TARGET(REPO) NAME(TRANA, DBA, RTCA, PG...
Name      Type      MbrName  CC
DBA       DB        IMS1     0
IMS1      LIST     IMS1     0
IMS3      LIST     IMS1     0
PGMA      PGM      IMS1     0
RTCA      RTC      IMS1     0
TRANA     TRAN     IMS1     0

```

When the PF4 key is pressed, the following is displayed:

Log for . . . : EXPORT DEFN TARGET(REPO) NAME(TRANA,DBA,RTCA,PG... More: >

```
IMSpIex . . . . . : PLEX1
Routing . . . . . : IMS1
Start time . . . . : 2011.123 22:39:45.76
Stop time . . . . . : 2011.123 22:39:45.96
Return code . . . . : 00000000
Reason code . . . . : 00000000
Reason text . . . . :
Command master. . . : IMS1
```

MbrName Messages

```
-----
IMS1      DFS3406I EXPORT COMMAND COMPLETE FOR ALL, REPOTYPE=IMSRSC, REPONAME=IMS_REPOS
```

OM API input:

```
CMD(EXPORT DEFN TARGET(REPO) NAME(TRANA,DBA,RTCA,PGMA) TYPE(ALL) SET(IMSID(IMS1,IMS3)))
```

OM API output:

```
<imsout>
<ctl>
<omname>OM10M </omname>
<omvsn>1.5.0</omvsn>
<xmlvsn>20 </xmlvsn>
<statime>2011.124 05:39:45.784253</statime>
<stotime>2011.124 05:39:45.958539</stotime>
<staseq>C7B7CF7E6C1BD337</staseq>
<stoseq>C7B7CF7E96A8B4F7</stoseq>
<rqsttkn1>USRT011 10223945</rqsttkn1>
<rc>00000000</rc>
<rsn>00000000</rsn>
</ctl>
<cmd>
<master>IMS1 </master>
<userid>USRT011 </userid>
<verb>EXP </verb>
<kwd>DEFN </kwd>
<input>EXPORT DEFN TARGET(REPO) NAME(TRANA,DBA,RTCA,PGMA)
      TYPE(ALL) SET(IMSID(IMS1,IMS3)) </input>
</cmd>
<cmdrsphdr>
<hdr slbl="NAME" llbl="Name" scope="LCL" sort="a" key="2" scroll="no"
  len="8" dtype="CHAR" align="left" />
<hdr slbl="TYPE" llbl="Type" scope="LCL" sort="a" key="1" scroll="no"
  len="8" dtype="CHAR" skipb="yes" align="left" />
<hdr slbl="MBR" llbl="MbrName" scope="LCL" sort="a" key="3" scroll="no"
  len="8" dtype="CHAR" align="left" />
<hdr slbl="CC" llbl="CC" scope="LCL" sort="n" key="0" scroll="yes"
  len="4" dtype="INT" align="right" skipb="no" />
<hdr slbl="CCTXT" llbl="CCText" scope="LCL" sort="n" key="0"
  scroll="yes" len="*" dtype="CHAR" skipb="yes" align="left" />
<hdr slbl="ERRT" llbl="ErrorText" scope="LCL" sort="n" key="0"
  scroll="yes" len="*" dtype="CHAR" skipb="yes" align="left" />
</cmdrsphdr>
<cmdrspdata>
<rsp>NAME(DBA ) TYPE(DB) MBR(IMS1 ) CC( 0) </rsp>
<rsp>NAME(PGMA ) TYPE(PGM) MBR(IMS1 ) CC( 0) </rsp>
<rsp>NAME(RTCA ) TYPE(RTC) MBR(IMS1 ) CC( 0) </rsp>
<rsp>NAME(TRANA ) TYPE(TRAN) MBR(IMS1 ) CC( 0) </rsp>
<rsp>NAME(IMS1 ) TYPE(LIST) MBR(IMS1 ) CC( 0) </rsp>
<rsp>NAME(IMS3 ) TYPE(LIST) MBR(IMS1 ) CC( 0) </rsp>
</cmdrspdata>
<msgdata>
<mbr name="IMS1 ">
<msg>DFS3406I EXPORT COMMAND COMPLETE FOR ALL, REPOTYPE=IMSRSC,
      REPONAME=IMS_REPOS </msg>
</mbr>
</msgdata>
</imsout>
```

**Explanation:** The runtime resource definitions for the database named DBA, transaction named TRANA, program named PGMA, and routing code named RTCA are exported to the repository as the stored resource definitions for IMS1 and IMS3.

The command is processed by the command master IMS. In this case, only IMS2 processed the command.

The IMS resource lists for IMS systems IMS1 and IMS3 are updated and are available for those IMS systems to import runtime resource definitions. The IMS resource list for the command master IMS2 is not updated in the repository because it is not specified in the SET(IMSID()) keyword.

This example shows how to use the **EXPORT** command to update the IMS resource list for another IMS in the IMSplex.

### Example 8 for EXPORT command

TSO SPOC input:

```
EXPORT DEFN TARGET(REPO) NAME(*) TYPE(PGM,PGMDESC,TRAN,TRANDESC)
SET(IMSID(*))
```

TSO SPOC output:

```
Log for . . : EXPORT DEFN TARGET(REPO) NAME(*) TYPE(PGM,PGMDES... More:  +>
```

```
IMSplex . . . . . : PLEX1
Routing . . . . . : IMS2
Start time . . . . : 2011.124 14:05:50.22
Stop time . . . . . : 2011.124 14:05:50.27
Return code . . . . : 0200000C
Reason code . . . . : 00003008
Reason text . . . . : None of the clients were successful.
Command master. . . : IMS2
```

| MbrName | Return Code | Reason Code | Reason text                        |
|---------|-------------|-------------|------------------------------------|
| -----   | -----       | -----       | -----                              |
| IMS2    | 00000010    | 0000450B    | Repository Server is not available |

MbrName Messages

```
-----
IMS2      DFS3407E EXPORT COMMAND COMPLETE FOR NONE, REQUEST=CSLRPUPD,
RC=03000014, RSN=00005508, ERRORTXT=, MBR=RSC, REPOTYPE=IMSRSC, REPONAME=IMS_REPOS
```

OM API input:

```
CMD(EXPORT DEFN TARGET(REPO) NAME(*) TYPE(PGM,PGMDESC,TRAN,TRANDESC)
SET(IMSID(*)))
```

OM API output:

```
<imsout>
<ctl>
<omname>OM10M </omname>
<omvsn>1.5.0</omvsn>
<xmlvsn>20 </xmlvsn>
<statime>2011.124 21:05:50.248438</statime>
<stotime>2011.124 21:05:50.270743</stotime>
<staseq>C7B89E7CD31F676E</staseq>
<stoseq>C7B89E7CD891703C</stoseq>
<rqsttkn1>USRT011 10140550</rqsttkn1>
<rc>0200000C</rc>
<rsn>00003008</rsn>
<rsnmsg>CSLN054I</rsnmsg>
<rsntxt>None of the clients were successful.</rsntxt>
</ctl>
<cmderr>
<mbr name="IMS2 ">
<typ>IMS </typ>
<styp>DBDC </styp>
<rc>00000010</rc>
<rsn>0000450B</rsn>
<rsntxt>Repository Server is not available</rsntxt>
</mbr>
</cmderr>
<cmd>
<master>IMS2 </master>
<userid>USRT011 </userid>
<verb>EXP </verb>
```



```

<kwd>DEFN          </kwd>
<input>EXPORT DEFN TARGET(REPO) NAME(*) TYPE(PGM,PGMDESC,TRAN,TRANDESC)
SET(IMSID(*)) </input>
</cmd>
<msgdata>
<mbri name="IMS2      ">
<msg>DFS3407E EXPORT COMMAND COMPLETE FOR NONE, REQUEST=CSLRPUPD,
RC=03000014, RSN=00005508, ERRORTXT=, MBR=RSC, REPOTYPE=IMSRSC,
REPONAME=IMS_REPOS          </msg>
</mbri>
</msgdata>
</imsout>

```

**Explanation:** The export of the program and transaction resources and descriptors to the repository failed because the Repository Server was not available. The CSLRPUPD return and reason codes of 03000014/00005508 indicates that the Repository Server is not available. See the CSLRRR macro for a description of the return code and reason code.

### Example 9 for EXPORT command

TSO SPOC input:

```

EXPORT DEFN TARGET(REPO) NAME(DBA,PGMA,RTCA,TRANA) TYPE(ALL)
SET(IMSID(*)) OPTION(ALLRSP)

```

TSO SPOC output:

```

Response for: EXPORT DEFN TARGET(REPO) NAME(DBA,PGMA,RTCA,TRAN...
Name      Type      MbrName   CC CText
DBA       DB          IMS2      1D0 NOT DONE DUE TO ERROR
IMS1     LIST       IMS2      1D0 NOT DONE DUE TO ERROR
IMS2     LIST       IMS2      1D0 NOT DONE DUE TO ERROR
IMS3     LIST       IMS2      1D0 NOT DONE DUE TO ERROR
PGMA     PGM        IMS2      1D0 NOT DONE DUE TO ERROR
RTCA     RTC        IMS2      1D0 NOT DONE DUE TO ERROR
TRANA    TRAN       IMS2      67 NO PGM DEFINED

```

When the PF4 key is pressed, the following is displayed:

```

Log for . . : EXPORT DEFN TARGET(REPO) NAME(DBA,PGMA,RTCA,TRAN... More:  +>

IMSpIex . . . . . : PLEX1
Routing . . . . . : IMS2
Start time. . . . : 2011.124 11:32:16.90
Stop time . . . . : 2011.124 11:32:17.19
Return code . . . : 0200000C
Reason code . . . : 00003008
Reason text . . . : None of the clients were successful.
Command master. . : IMS2

MbrName      Return      Reason
Code         Code         Reason text
-----
IMS2         0000000C    00003004    No requests were successful

MbrName      Messages
-----
IMS2         DFS3407E EXPORT COMMAND COMPLETE FOR NONE, REQUEST=CSLRPUPD,
RC=0300000C, RSN=00003004, ERRORTXT=00000000 03000008 00002514 00000000
00000000 00000000, MBR=RSC, REPOTYPE=IMSRSC, REPONAME=IMS_REPOS

```

OM API input:

```

CMD(EXPORT DEFN TARGET(REPO) NAME(DBA,PGMA,RTCA,TRANA) TYPE(ALL)
SET(IMSID(*)) OPTION(ALLRSP))

```

OM API output:

```

<imsout>
<ctl>
<omname>OM10M </omname>
<omvsn>1.5.0</omvsn>
<xmlvsn>20 </xmlvsn>
<statime>2011.124 18:32:16.943085</statime>
<stotime>2011.124 18:32:17.187129</stotime>

```

```

<staseq>C7B87C2A54FEDBEC</staseq>
<stoseq>C7B87C2A909390F0</stoseq>
<rqsttkn1>USRT011 10113216</rqsttkn1>
<rc>0200000C</rc>
<rsn>00003008</rsn>
<rsnmsg>CSLN054I</rsnmsg>
<rsntxt>None of the clients were successful.</rsntxt>
</ctl>
<cmderr>
<mbr name="IMS2 ">
<typ>IMS </typ>
<styp>DBDC </styp>
<rc>0000000C</rc>
<rsn>00003004</rsn>
<rsntxt>No requests were successful</rsntxt>
</mbr>
</cmderr>
<cmd>
<master>IMS2 </master>
<userid>USRT011 </userid>
<verb>EXP </verb>
<kwd>DEFN </kwd>
<input>EXPORT DEFN TARGET(REPO) NAME(DBA,PGMA,RTCA,TRANA)
TYPE(ALL)SET(IMSID(*)) OPTION(ALLRSP) </input>
</cmd>
<cmdrsphdr>
<hdr slbl="NAME" llbl="Name" scope="LCL" sort="a" key="2" scroll="no"
len="8" dtype="CHAR" align="left" />
<hdr slbl="TYPE" llbl="Type" scope="LCL" sort="a" key="1" scroll="no"
len="8" dtype="CHAR" skipb="yes" align="left" />
<hdr slbl="MBR" llbl="MbrName" scope="LCL" sort="a" key="3" scroll="no"
len="8" dtype="CHAR" align="left" />
<hdr slbl="CC" llbl="CC" scope="LCL" sort="n" key="0" scroll="yes"
len="4" dtype="INT" align="right" skipb="no" />
<hdr slbl="CCTXT" llbl="CCText" scope="LCL" sort="n" key="0"
scroll="yes" len="*" dtype="CHAR" skipb="yes" align="left" />
<hdr slbl="ERRT" llbl="ErrorText" scope="LCL" sort="n" key="0"
scroll="yes" len="*" dtype="CHAR" skipb="yes" align="left" />
</cmdrsphdr>
<cmdrspdata>
<rsp>NAME(DBA ) TYPE(DB) MBR(IMS2 ) CC( 1D0) CCTXT(NOT DONE DUE TO ERROR) </
rsp>
<rsp>NAME(PGMA ) TYPE(PGM) MBR(IMS2 ) CC( 1D0) CCTXT(NOT DONE DUE TO ERROR) </
rsp>
<rsp>NAME(RTCA ) TYPE(RTC) MBR(IMS2 ) CC( 1D0) CCTXT(NOT DONE DUE TO ERROR) </
rsp>
<rsp>NAME(TRANA ) TYPE(TRAN) MBR(IMS2 ) CC( 67) CCTXT(NO PGM
DEFINED) </rsp>
<rsp>NAME(IMS1 ) TYPE(LIST) MBR(IMS2 ) CC( 1D0) CCTXT(NOT DONE DUE TO ERROR) </
rsp>
<rsp>NAME(IMS2 ) TYPE(LIST) MBR(IMS2 ) CC( 1D0) CCTXT(NOT DONE DUE TO ERROR) </
rsp>
<rsp>NAME(IMS3 ) TYPE(LIST) MBR(IMS2 ) CC( 1D0) CCTXT(NOT DONE DUE TO ERROR)</
rsp>
</cmdrspdata>
<msgdata>
<mbr name="IMS2 ">
<msg>DFS3407E EXPORT COMMAND COMPLETE FOR NONE, REQUEST=CSLRPUPD,
RC=0300000C, RSN=00003004, ERRORTXT=00000000 03000008 00002514
00000000 00000000 00000000, MBR=RSC, REPOTYPE=IMSRSC,
REPONAME=IMS_REPOS </msg>
</mbr>
</msgdata>
</imsout>

```

**Explanation:** The export of the program, transaction, database, and routing code resource definitions to the repository failed because the definition for the program referenced by TRANA does not exist in the repository and is not being exported. A completion code of 1D0, Not done due to error, is returned for all members being updated in the repository except the one that failed. If the error is due to a resource, MBR=RSC is set in the DFS3407E message.

#### **Example 10 for EXPORT command**

TSO SPOC input:

```
EXPORT DEFN TARGET(REPO) NAME(DBA,PGMA,RTCA,TRANA) TYPE(ALL)
SET(IMSID(IM1*)) OPTION(ALLRSP)
```

## TSO SPOC output:

```
Response for: EXPORT DEFN TARGET(REPO) NAME(DBA,PGMA,RTCA,TRAN...
Name      Type      MbrName    CC CText
DBA       DB         IMS2       1D0 NOT DONE DUE TO ERROR
IM1*     LIST      IMS2       1D5 NO IMS RESOURCE LIST
PGMA     PGM       IMS2       1D0 NOT DONE DUE TO ERROR
RTCA     RTC       IMS2       1D0 NOT DONE DUE TO ERROR
TRANA    TRAN      IMS2       1D0 NOT DONE DUE TO ERROR
```

## When the PF4 key is pressed, the following is displayed:

```
Log for . . : EXPORT DEFN TARGET(REPO) NAME(DBA,PGMA,RTCA,TRAN... More: +>
```

```
IMSpIex . . . . . : PLEX1
Routing . . . . . : IMS2
Start time . . . . : 2011.124 12:21:47.67
Stop time . . . . . : 2011.124 12:21:47.76
Return code . . . . : 0200000C
Reason code . . . . : 00003008
Reason text . . . . : None of the clients were successful.
Command master . . : IMS2
```

| MbrName | Return Code | Reason Code | Reason text                 |
|---------|-------------|-------------|-----------------------------|
| IMS2    | 0000000C    | 00003004    | No requests were successful |

### MbrName Messages

```
IMS2 DFS3407E EXPORT COMMAND COMPLETE FOR NONE, REQUEST=CSLRPUPD,
RC=0300000C, RSN=00003004, ERRORTXT=, MBR=LST, REPOTYPE=IMSRSC,
REPONAME=IMS_REPOS
```

## OM API input:

```
CMD(EXPORT DEFN TARGET(REPO) NAME(DBA,PGMA,RTCA,TRANA) TYPE(ALL)
SET(IMSID(IM1*)) OPTION(ALLRSP))
```

## OM API output:

```
<imsout>
<ctl>
<omname>OM10M </omname>
<omvsn>1.5.0</omvsn>
<xmlvsn>20 </xmlvsn>
<statime>2011.124 19:21:47.695676</statime>
<stotime>2011.124 19:21:47.758331</stotime>
<staseq>C7B8873B7663C765</staseq>
<stoseq>C7B8873B85AFBBEA</stoseq>
<rqsttkn1>USRT011 10122147</rqsttkn1>
<rc>0200000C</rc>
<rsn>00003008</rsn>
<rsnmsg>CSLN054I</rsnmsg>
<rsntxt>None of the clients were successful.</rsntxt>
</ctl>
<cmderr>
<mbr name="IMS2 ">
<typ>IMS </typ>
<styp>DBDC </styp>
<rc>0000000C</rc>
<rsn>00003004</rsn>
<rsntxt>No requests were successful</rsntxt>
</mbr>
</cmderr>
<cmd>
<master>IMS2 </master>
<userid>USRT011 </userid>
<verb>EXP </verb>
<kwd>DEFN </kwd>
<input>EXPORT DEFN TARGET(REPO) NAME(DBA,PGMA,RTCA,TRANA)
TYPE(ALL)SET(IMSID(IM1*)) OPTION(ALLRSP) </input>
</cmd>
<cmdsphdr>
<hdr s1b1="NAME" llb1="Name" scope="LCL" sort="a" key="2" scroll="no"
len="8" dtype="CHAR" align="left" />
<hdr s1b1="TYPE" llb1="Type" scope="LCL" sort="a" key="1" scroll="no"
len="8" dtype="CHAR" skipb="yes" align="left" />
```

```

<hdr slbl="MBR" llbl="MbrName" scope="LCL" sort="a" key="3" scroll="no"
  len="8" dtype="CHAR" align="left" />
<hdr slbl="CC" llbl="CC" scope="LCL" sort="n" key="0" scroll="yes"
  len="4" dtype="INT" align="right" skipb="no" />
<hdr slbl="CCTXT" llbl="CCText" scope="LCL" sort="n" key="0"
  scroll="yes" len="*" dtype="CHAR" skipb="yes" align="left" />
<hdr slbl="ERRT" llbl="ErrorText" scope="LCL" sort="n" key="0"
  scroll="yes" len="*" dtype="CHAR" skipb="yes" align="left" />
</cmdrsphdr>
<cmdrspdata>
<rsp>NAME(DBA      ) TYPE(DB) MBR(IMS2      ) CC( 1D0) CCTXT(NOT DONE DUE TO ERROR) </
rsp>
<rsp>NAME(PGMA     ) TYPE(PGM) MBR(IMS2      ) CC( 1D0) CCTXT(NOT DONE DUE TO ERROR) </
rsp>
<rsp>NAME(RTCA     ) TYPE(RTC) MBR(IMS2      ) CC( 1D0) CCTXT(NOT DONE DUE TO ERROR) </
rsp>
<rsp>NAME(TRANA    ) TYPE(TRAN) MBR(IMS2      ) CC( 1D0) CCTXT(NOT DONE DUE TO ERROR) </
rsp>
<rsp>NAME(IM1*     ) TYPE(LIST) MBR(IMS2      ) CC( 1D5) CCTXT(NO IMS
RESOURCE LIST) </rsp>
</cmdrspdata>
<msgdata>
<mbr name="IMS2      ">
<msg>DFS3407E EXPORT COMMAND COMPLETE FOR NONE, REQUEST=CSLRPUPD,
RC=0300000C, RSN=00003004, ERRORTXT=, MBR=LST, REPOTYPE=IMSRSC,
REPONAME=IMS_REPOS                                </msg>
</mbr>
</msgdata>
</imsout>

```

**Explanation:** The export of the program, transaction, database, and routing code resource definitions to the repository failed because there are no IMS resource lists in the repository that match the wildcard value IM1\*. A completion code of 1D0, Not done due to error, is returned for all the members being updated in the repository except the one that failed. MBR=LST indicates that the error is for an IMS resource list.

### Related concepts

[How to interpret CSL request return and reason codes \(System Programming APIs\)](#)

[CSL RM, IMS, and Repository Server termination \(System Administration\)](#)

[IMSRSC repository administration \(System Administration\)](#)

[Resource definition data sets \(System Definition\)](#)

### Related reference

[“Command keywords and their synonyms” on page 59](#)

All IMS command keywords and their synonyms, as well as keywords supported by the OM API, are listed. The list covers command keywords for the OM command processing clients such as IMS, ODBM, IMSCON, and RM.

## Chapter 33. /FORMAT command

Use the **/FORMAT** command to cause a specific format to be displayed on a physical terminal using the IMS Message Format Service (MFS).

The displayed format is used by IMS in processing the next input from the formatted terminal.

Subsections:

- [“Environment” on page 769](#)
- [“Syntax” on page 769](#)
- [“Keywords” on page 769](#)
- [“Usage notes” on page 770](#)
- [“Example” on page 770](#)

### Environment

The following table lists the environments (DB/DC, DBCTL, and DCCTL) from which the command and keyword can be issued.

Table 330. Valid environments for the /FORMAT command and keyword

| Command / Keyword | DB/DC | DBCTL | DCCTL |
|-------------------|-------|-------|-------|
| <b>/FORMAT</b>    | X     |       | X     |
| LTERM             | X     |       | X     |

### Syntax



### Keywords

The following keywords are valid for the **/FORMAT** command:

#### **modname**

Specifies the name of the message output descriptor (MOD) to be used to format the terminal.

#### **LTERM**

Specifies the name of the logical terminal to be formatted. LTERM is required when a terminal other than the input terminal is to be formatted. If LTERM is not specified, the input physical terminal must have at least one LTERM assigned.

If the *ltermname* does not exist, an attempt is made to create the lterm and associated user structure. The command creates this structure by queuing the format and data, if any exists, to the terminal as if it were a message. This process is similar to a message switch, a message insert, or a **/BROADCAST LTERM**, all of which queue a message to an LTERM.

The format request is rejected if the specified LTERM is:

- Assigned to a physical terminal that is not supported by MFS
- In line-response mode or exclusive mode
- Involved in an active conversation

- An input-only terminal
- Not the alternate master in an XRF system
- A remote LTERM

In an IMSplex, **/FORMAT LTERM** can be used to queue a format to an LTERM that is not active or that is active on any IMS in the IMSplex.

### **data**

Is a string consisting of 1 to 8 characters to be inserted into the output message created for the terminal being formatted. Since MFS treats the data as application program output data, the data string can be used to select a logical page (LPAGE) within the requested MOD. The way the selection is performed is determined by the requested MOD's LPAGE definitions.

## **Usage notes**

Using a password with the **/FORMAT** command is not valid.

The **/FORMAT** command, where an IMS-supplied default *modname* is used, is not effective for a 3270 master terminal that uses the MFS master terminal formatting option.

**Recommendation:** If a format is lost during a conversation, do not use the **/FORMAT** command to restore the format. Instead, enter a **/HOLD** command followed by a **/RELEASE** command to display the first physical page of the current message and restore the format.

## **Example**

Remote Terminal entry:

```
/FORMAT DFSM04
/BROADCAST LTERM WTOR (eos)
this is segment 1 (eos)
this is segment 2 (eos)
this is segment 3 (eom)
```

Response ET:

```
DFS058I BROADCAST COMMAND COMPLETED
```

Response RT:

```
THIS IS SEGMENT 1
THIS IS SEGMENT 2
THIS IS SEGMENT 3
```

Explanation: The remote terminal is first formatted by the **/FORMAT** command, where default format DFSM04 supports the input of 4 segments. This is followed by **/BROADCAST** with four segments.

## Chapter 34. /HOLD command

Use the **/HOLD** command to suspend and save a currently active conversation.

Subsections:

- [“Environment” on page 771](#)
- [“Syntax” on page 771](#)
- [“Usage notes” on page 771](#)
- [“Example” on page 771](#)

### Environment

The following table lists the environments (DB/DC, DBCTL, and DCCTL) from which the command can be issued.

*Table 331. Valid environments for the /HOLD command*

| Command      | DB/DC | DBCTL | DCCTL |
|--------------|-------|-------|-------|
| <b>/HOLD</b> | X     |       | X     |

### Syntax

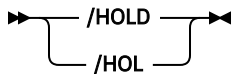

### Usage notes

The IMS response to **/HOLD** provides a conversation identification that must be used later when the held conversation is resumed (**/RELEASE** command) or terminated (**/EXIT**).

In an IMSplex, if global resource information is kept in Resource Manager, **/HOLD** suspends and saves the active conversation globally in Resource Manager. If global resource information is not kept in Resource Manager, **/HOLD** suspends and saves the active conversation locally.

### Example

Entry ET:

```
/HOLD
```

Response ET:

```
DFS999I HELD CONVERSATION ID IS 0001
```

Explanation: The active conversation is saved and is assigned an identification of 0001.





# Chapter 35. /IDLE command

The **/IDLE** command is used to immediately terminate input from, or output to, physical terminals assigned to the lines, logical links, or nodes specified in the command.

Partially processed input messages on the lines specified in the command are discarded. Output messages being sent are returned to the message queues for later transmission

This command can be issued to an IMSplex using the Batch SPOC utility.

Subsections:

- “Environment” on page 773
- “Syntax” on page 773
- “Keywords” on page 774
- “Examples” on page 775

## Environment

The following table lists the environments (DB/DC, DBCTL, and DCCTL) in which you can use the command and keywords.

*Table 332. Valid environments for the /IDLE command and keywords*

| Command / Keywords | DB/DC | DBCTL | DCCTL |
|--------------------|-------|-------|-------|
| <b>/IDLE</b>       | X     |       | X     |
| LINE               | X     |       | X     |
| LINK               | X     |       | X     |
| NODE               | X     |       | X     |
| NOSHUT             | X     |       | X     |

## Syntax

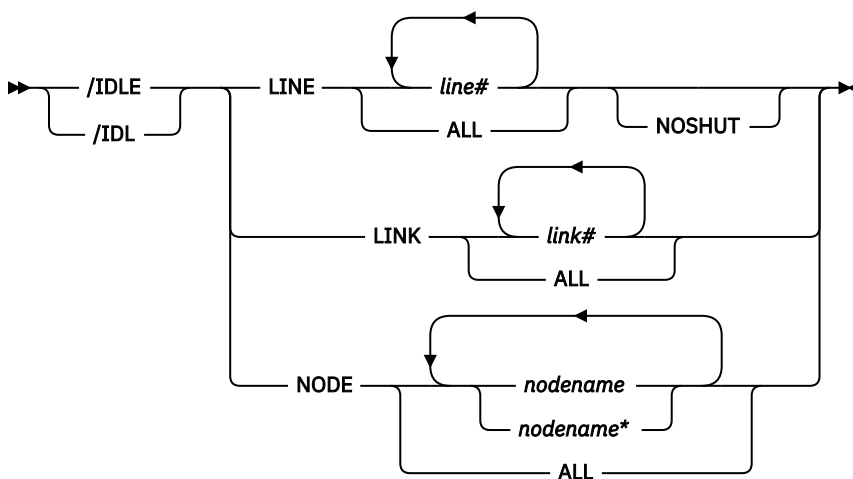

## Keywords

The following keywords are valid for the **/IDLE** command:

### LINE

Specifies the communication line to be immediately terminated.

**/IDLE** does not apply to the system console line, the master terminal line, or the secondary master terminal line. If these lines are specified, a DFS058 COMMAND COMPLETED EXCEPT LINE X message is returned. If the master terminal is assigned to a line that must be idle, the master terminal must be reassigned to a different line before **/IDLE** is specified.

### NOSHUT

Immediately terminates input to and output from 3270 remote non-VTAM lines without a checkpoint shutdown. **/IDLE** cannot be entered before a checkpoint unless the NOSHUT keyword is included in the command. NOSHUT is only valid if IMS is not in the process of shutting down and is mutually exclusive with the NODE parameter. When **/IDLE LINE line# NOSHUT** is entered, the 3270 remote non-VTAM lines must be stopped or process stopped. A DFS058 COMMAND COMPLETED EXCEPT LINE X message is returned if the command is entered and one of the following conditions exists:

- The line is the master terminal line or system console line, including the secondary master terminal line.
- The line is not stopped or process stopped.
- The line is not a 3270 remote non-VTAM line.
- The line is not open.
- The line is deactivated by IMS.

If the line specified with the NOSHUT keyword belongs to a line group, the input and output for all lines within the group are immediately terminated. If the line belonging to the line group has the master terminal assigned to it, the **/IDLE LINE line# NOSHUT** command is rejected.

To restart the lines idled by the **/IDLE LINE line# NOSHUT** command, either the **/START LINE** or **/RSTART LINE** command must be entered.

### LINK

Specifies the logical link from which input, or to which output, is to be terminated. (No input messages are lost with **/IDLE LINK**.)

If a checkpoint shutdown is not in progress, only MSC VTAM links are valid. All non-MSC VTAM links require a shutdown checkpoint in progress. IMS returns a DFS058 IDLE COMMAND COMPLETED EXCEPT LINK X message if one of the following conditions exists:

- The link is idled already.
- The link is not connected.
- The link cannot be opened.
- A shutdown checkpoint is not in progress (for non-MSC VTAM links).

For MSC TCP/IP logical links that are active, the **/IDLE LINK** command immediately terminates the link. The **/IDLE LINK** command is similar to the **/PSTOP LINK FORCE** command because the **/PSTOP LINK FORCE** command also immediately terminates a TCP/IP logical link that is active. However, the **/IDLE LINK** command is processed only during IMS shutdown, whereas the **/PSTOP LINK FORCE** can be processed at any time.

IMS performs the following actions when it processes the **/IDLE LINK** command for an active TCP/IP link:

1. Terminates the link in the IMS system where the command is issued.
2. Notifies the local IMS Connect instance to clean up the send socket.
3. Issues the DFS2169I DISCONNECTION COMPLETED ON LINK informational message.

4. Places the link in PSTOPPED ERE IDLE status.

An **/IDLE LINK link#** command internally causes issuing of the VTAM command:

```
VARY NET,TERM,TYPE=FORCE,NOTIFY=N0,SCOPE=ALL,LU1=xxxxxxxx,LU2=yyyyyyyy
```

All logical links, assigned to the same physical link, associated with the named logical link (link#) will be stopped. That is, all parallel sessions on the same physical link will be stopped. The **/RSTART LINK** command is used to reactivate links or sessions.

The **/IDLE LINK link#** command should not be used as the first attempt to stop the link. If the MSC link appears to be hung, the IMS operator should:

1. First attempt to stop the link with the **IMS /PSTOP** command.
2. If this fails, display the link session status through VTAM, using the VTAM command:

```
D NET,ID=xxxxxxxx
```

or the VTAM command:

```
D NET,SESSIONS,LIST=ALL
```

3. If the link session is still active (STATUS=ACTIV), terminate it with the **/IDLE LINK** command or the VTAM command:

```
VARY NET,TERM,TYPE=FORCE,LU1=xxxxxxxx
```

**Note:** All parallel sessions associated with the link will be terminated.

## NODE

Specifies the VTAM node to which output is to be terminated, or from which input is to be terminated. The master terminal only can be idled when specifically named.

If the **/IDLE NODE nodename** command is entered for an ISC node defined with users, all half-sessions of the specified node are affected.

An **/IDLE NODE ALL** command causes the VTAM command VARY NET,INACT, to be issued to all nodes still connected to IMS, except the master terminal.

If the **/IDLE NODE** command is entered prior to IMS entering shutdown, the **/ACT** command can be entered to reactivate the node in VTAM. If the **/IDLE NODE** command is entered while in IMS shutdown, a **VARY NET,ACT** command might have to be entered directly to VTAM. However, before using the **/IDLE** command, a **/CLSDST** and then a **/CLSDST FORCE** command should be tried.

The node parameter can be generic. The generic parameter specifies nodes that already exist.

## Examples

The following are examples of the **/IDLE** command:

### Example 1 for /IDLE command

Entry ET:

```
/IDLE LINE 14 24
```

Response ET:

```
DFS058I IDLE COMMAND COMPLETED
```

Explanation: The I/O on lines 14 and 24 is forced to terminate.

### Example 2 for /IDLE command

Entry ET:

```
/IDLE LINE 4 NOSHUT
```

Response ET:

```
DFS058I IDLE COMMAND COMPLETED
```

Explanation: The I/O on line 4, which is a 3270 remote non-VTAM line, is forced to terminate.

***Example 3 for /IDLE command***

Entry ET:

```
/IDLE LINK 2
```

Response ET:

```
DFS058I IDLE COMMAND COMPLETED
```

Explanation: The input/output on logical link 2 is forced to terminate.

***Example 4 for /IDLE command***

Entry ET:

```
/IDLE NODE ABC
```

Response ET:

```
DFS058I IDLE COMMAND COMPLETED
```

Explanation: A **VARY NET, INACT** command is executed that will cause the IMS VTAM LOSTERM exit to be entered with an indication that the session has been terminated.

---

## Chapter 36. IMPORT commands

Use the IMS **IMPORT** commands to import resources and resource descriptors.

These commands can be issued through TSO SPOC, IBM Management Console for IMS and DB2 for z/OS, the Manage Resources options in the IMS Applications menu, or other user-written programs that issue commands through OM API. These commands can also be issued to an IMSplex by using the Batch SPOC utility.

Subsections:

- [“CREATE DB command” on page 175](#)
- [“CREATE DBDESC command” on page 182](#)
- [“CREATE IMSCON commands” on page 188](#)
- [“CREATE OTMADESC command” on page 244](#)
- [“CREATE PGM command” on page 254](#)
- [“CREATE PGMDESC command” on page 265](#)
- [“CREATE RTC command” on page 274](#)
- [“CREATE RTCDESC command” on page 280](#)
- [“CREATE TRAN command” on page 285](#)
- [“CREATE TRANDESC command” on page 307](#)

---

### IMPORT DEFN SOURCE(CATALOG) command

When the IMS management of ACBs is enabled, use the **IMPORT DEFN SOURCE(CATALOG)** command to activate application and database resource definitions (PSBs and DBDs) in an online IMS system by importing them from the staging data set of the IMS catalog.

The IMS management of ACBs must be enabled before you can use the **IMPORT DEFN SOURCE(CATALOG)** command. If the IMS management of ACBs is not enabled, **IMPORT DEFN SOURCE(CATALOG)** is rejected. For more information about the IMS management of ACBs, see [IMS management of ACBs \(System Definition\)](#).

If you are modifying certain types of PSBs in an IMSplex that uses a shared IMS catalog, you can activate the modified PSBs in a subset of the IMS systems by using the UPDATEPSB and REFRESHPSB options. You can then test the application changes in the subset before you activate the changes across the entire IMSplex.

You can use the UPDATEPSB option for GSAM DBDs, so that when the IMPORT command is issued with the FOR(IMSID()) keyword, any GSAM DBDs in the staging data set are activated in the IMS directory.

Specify the FOR(IMSID()) keyword without the OPTION() keyword to perform one or all of the following operations:

- Updating staged PSBs and GSAM DBDs
- Refreshing pending PSBs

The **IMPORT** command can be issued through TSO SPOC, IBM Management Console for IMS and DB2 for z/OS, the Manage Resources options in the IMS Applications menu, or any user-written programs that issue commands through OM API. These commands can also be issued to an IMSplex by using the Batch SPOC utility.

Subsections:

- [“Environment” on page 778](#)
- [“Syntax” on page 778](#)
- [“Keywords” on page 779](#)

- [“Usage notes” on page 781](#)
- [“Output fields” on page 783](#)
- [“Return and reason codes” on page 785](#)
- [“Completion codes” on page 787](#)
- [“Examples” on page 797](#)

## Environment

The following table lists the environments (DB/DC, DBCTL, and DCCTL) in which you can use the command and keywords.

Table 333. Valid environments for the IMPORT command and keywords

| Command / Keywords | DB/DC | DBCTL | DCCTL |
|--------------------|-------|-------|-------|
| <b>IMPORT DEFN</b> | X     | X     | X     |
| OPTION             | X     | X     | X     |
| SOURCE(CATALOG)    | X     | X     |       |

## Syntax

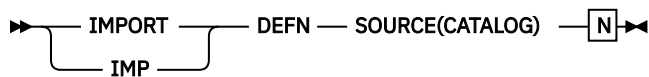

**N**

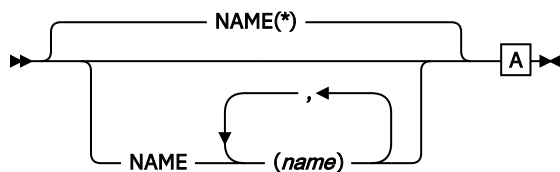

**A**

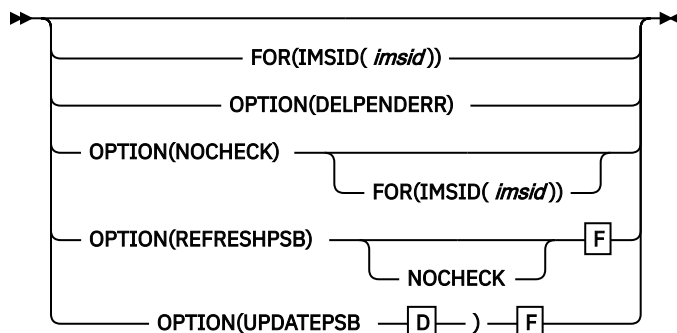

**D**

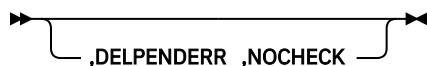

**F**



## Keywords

The following keywords are valid for the **IMPORT** command:

### DEFN

A required keyword.

### FOR()

When the **OPTION()** keyword is specified, specifies which IMS systems in the IMS sysplex are to participate in the **IMPORT** process. Depending on the type of resources that are being imported and the state of processing in each IMS system, the options that are specified on the **OPTION()** keyword might impact systems that are not listed in the **FOR(IMSID())** keyword. For more information, see the description of the **OPTIONS()** keyword.

### IMSID()

Specify one or more comma-separated IMS IDs of the IMS systems that are to process the **IMPORT** command and the specified option.

The IMS ID specified on the **FOR(IMSID())** keyword must be an IMS that exists within the IMSplex. The IMS specified might be active or down when the command is issued.

**Note:** Depending on the value that is specified on the **OPTION()** keyword, the IMS systems that are listed on the **IMSID()** keyword must either include or exclude the command master.

IMS selects a command master from the IMS systems that the command is routed to when the command is submitted. Therefore, to include the command master, route the command to one or more of the IMS systems that are specified on the **IMSID()** keyword. To exclude the command master, route the command to one or more IMS systems that are not specified on the **IMSID()** keyword.

When **OPTION(UPDATEPSB)** is specified, one of the IMS systems that is specified on the **IMSID()** keyword must be the command master, so route the **IMPORT DEFN** command to only the specified IMS systems.

When either of the preceding options is specified, if the command is routed to all IMS systems in the IMSplex, either explicitly or by default, the success of the command is unpredictable because the IMS system that is selected as the command master is unpredictable.

To see a list of the IMS systems in your IMSplex, issue the **QUERY IMSPLEX TYPE(IMS) SHOW(ALL)** command.

### NAME

Specifies one or more 1 - 8 character names of database DBD or program PSB or both resources to import from the staging directory to the active directory. Wildcard names can be specified. The name is a repeatable parameter. If the **NAME** parameter specified is a specific name or a wildcard name, command responses are returned for all the resource names that are processed. **NAME** is an optional parameter, and if not specified, it defaults to **NAME(\*)**. Duplicate names are ignored.

For example, **IMPORT DEFN SOURCE(CATALOG) NAME(DB1,DB2\*,PSB1,PSB2%%)** is a valid combination of DBD or PSB (or both) name parameters.

When **NAME(\*)** is specified, all of the ACBs in the staging directory are imported. This is equivalent to the **IMPORT DEFN SOURCE(CATALOG)** command with no **NAME** keyword. If you specify **NAME(\*)**, it is not supported with any other **NAME** parameters.

For a successful **IMPORT** command, all the resources associated with the database DBD and program PSB resources that are specified on the **NAME()** keyword are also imported, except for GSAM. For GSAM DBDs and PSBs, only the named GSAM DBDs and PSBs are imported. If the associated PSB resources do not exist in the staging directory, the import command fails.

For example, if a DBD is in the staging directory, any of its index databases, logically related databases (including secondary index), and PSBs that are also in the staging directory will be imported.

In another example, if a PSB is in the staging directory, any of the database DBDs it references that are also in the staging directory will be imported.

When the OPTION(NOCHECK) is specified, only the resources specified on the NAME keyword are imported.

### **OPTION()**

Specifies optional functions of the command.

You can specify the following options:

#### **DELPENDERR**

Specifies that if errors occur during the prepare phase of IMPORT DEFN SOURCE(CATALOG) command processing, the pending resources are deleted from the staging data set. An error in the prepare phase is indicated by OLCPREPF in the IMPORT DEFN command output.

#### **NOCHECK**

OPTION(NOCHECK) is independent of OPTION(DELPENDERR), OPTION(UPDATEPSB), OPTION(REFRESHPSB), and FOR(IMSID(imsid)).

For metadata database changes, OPTION(NOCHECK) is not required to be specified when the associated PSBs of the changed database are not included in the staging directory. If OPTION(NOCHECK) is specified for metadata database changes, LclStatus of "NO-ASSOCIATED-PSB-FOUND-IN-STAGE" is returned in the command response.

If OPTION(NOCHECK) is specified, the IMPORT DEFN command imports database changes that are created without their associated PSBs that are included in the staging directory by using the DFS3UACB utility with BLDPSB=NO parameter or DDL ALTER.

#### **Note:**

The IMPORT DEFN command does not scan the directory to find PSBs in the catalog directory so that it can validate that the PSBs were rebuilt for the changed database.

If a changed database is built incorrectly and its PSBs must be rebuilt but are not included in staging directory, the OPTION(NOCHECK) will not detect missing rebuilt PSB errors because using this option does not scan directories for all PSBs that are required to be rebuilt. Not scanning for these PSBs can cause unpredictable problems such as IMS not being able to schedule programs or cause database integrity problems.

If you want to disable the OPTION(NOCHECK) for your organization, you can use the OM Input Exit to reject the IMPORT DEFN SOURCE(CATALOG) OPTION(NOCHECK) command in case OPTION(NOCHECK) is mistakenly specified in the IMPORT DEFN SOURCE(CATALOG) command.

#### **REFRESHPSB**

Causes the IMS systems that are listed in the FOR(IMSID()) option to reload from the IMS catalog directory data set all PSBs in the system that have a *refresh-pending* (REFP) status.

Specify the REFRESHPSB option to activate PSB changes in an IMSplex that were previously activated by the UPDATEPSB option in only a subset of the IMS systems in the IMSplex.

Program resources that might be affected by the changes must be stopped on the systems that are listed in the FOR() option.

PSB activation does not occur for systems that are not listed in the FOR(IMSID()) clause.

To see a list of the IMS systems in your IMSplex, issue the **QUERY IMSPLEX TYPE(IMS) SHOW(ALL)** command.

While the REFRESHPSB option is being processed by an IMS system, the system status includes RFSHPSB in the LclStat field of the QUERY MEMBER command output.

#### **UPDATEPSB**

In an IMSplex, activates PSB changes in the IMS catalog and causes the IMS systems that are listed in the FOR(IMSID()) option to reload the changed PSBs the next time the PSBs are scheduled. IMS systems that are omitted from the FOR(IMSID()) keyword are not notified by the



command to reload the modified PSBs and continue to use the original PSB definition in online memory until the REFRESHPSB option is submitted or another event, like a system restart, causes the PSB to be reloaded.

When 64-bit storage pools are enabled and the UPDATEPSB option is specified, IMS loads the old version of the non-resident PSBs into 64-bit storage. The PSBs are marked as refresh pending.

If the staging data set of the IMS catalog contains any DBDs when the UPDATEPSB option is specified, the IMPORT command fails.

The FOR(IMSID()) keyword is not effective for DOPT PSBs. After you issue the UPDATEPSB option, all IMS system that schedule the PSB in the IMSplex load the new, modified PSB from the IMS directory.

The FOR(IMSID()) keyword is effective for non-resident PSBs only if the PSB is cached in the 64-bit storage pools of the IMS systems that are not specified on the FOR(IMSID()) keyword.

Program resources that might be affected by the changes must be stopped on the systems that are listed in the FOR(IMSID()) option. Stopping the resources is not necessary for systems that are not listed in the FOR(IMSID()) option, unless the PSB is a DOPT PSB or a non-resident PSB that is not cached in the 64-bit storage pool of the systems.

All pending PSB changes in the staging data set are activated in the IMS systems that are listed in the FOR(IMSID()) clause when the IMPORT command is issued with the UPDATEPSB option.

When OPTION(UPDATEPSB) is specified, one of the IMS systems that is specified on the IMSID() keyword must be the command master, so route the IMPORT DEFN command to only the specified IMS systems.

To see a list of the IMS systems in your IMSplex, issue the **QUERY IMSPLEX TYPE(IMS) SHOW(ALL)** command.

While OPTION(UPDATEPSB) is being processed by an IMS system, the system status includes UPDPSB in the Lc1Stat field of the QUERY MEMBER command output.

### **SOURCE()**

Specifies the source of the resource definitions to be imported.

### **CATALOG**

A required parameter that indicates that the resources to be activated are to be imported into the online IMS systems from the staging data set of the IMS catalog.

## **Usage notes**

Before you run the **IMPORT DEFN SOURCE(CATALOG)** command, stop all existing database and program resources that will be affected by the changes.

However, for existing database resources with only metadata changes, for example, DATATYPE, EXTERNALNAME, REMARKS, and so on, you do not need to stop these database resources before you run the IMPORT DEFN SOURCE(CATALOG) command for nonstructural database changes.

After the command processing completes, restart all databases and programs that were stopped for the change.

When the **IMPORT DEFN SOURCE(CATALOG)** command is issued, IMS takes the following actions:

1. Adds or replaces the ACBs in the directory data set of the IMS catalog.
2. Removes the ACBs from the staging data set of the IMS catalog.
3. Removes all old copies of the resources from memory and casts out DMBs and PSBs from their respective pools.
4. If the IMS catalog is shared by multiple IMS systems, coordinates the change across the IMSplex.
5. Updates the IMS catalog HEADER segment for the imported objects.

When you issue the **IMPORT DEFN SOURCE(CATALOG)** command, IMS uses an internal process that is similar to the online change function to activate the resources in online IMS systems. Consequently, if you issue the **QUERY MEMBER** command during import processing, the status reflects the same prepare and commit phases that online change uses. If errors occur, the messages might also reflect these phases.

The **IMPORT DEFN SOURCE(CATALOG)** command can be issued only through the Operations Manager (OM) API. This command applies to DB/DC and DBCTL systems in which the IMS management of ACBs is enabled by ACBMGMT=CATALOG in the CATALOG section of the DFSDFxxx member.

The **IMPORT** command is not valid on the XRF alternate or FDBR region.

The **IMPORT DEFN SOURCE(CATALOG)** command is valid for the following resource types:

- Database descriptors (DBDs)
- Program views (PSBs) and their associated application control blocks (ACBs)

By default, when the **IMPORT** command is issued, OM routes the command to all active IMS systems (or to all IMS systems that are specified in the route list if the ROUTE parameter is specified on the CSLOMCMO or CSLOMI request) that registered interest in the command. All IMS systems that receive the command attempt to process the **IMPORT** command and import the resource definitions from the specified source. If you need the **IMPORT** command to be processed by a specific IMS, the ROUTE parameter must be used to direct the **IMPORT** command to the specific IMS.

If the **IMPORT** command processing fails because an SCI went down, issue the **QUERY MEMBER TYPE(IMS) SHOW(STATUS)** command to determine the state of all the IMSs in the IMSplex and the recommended action to take.

If the **IMPORT** command timed out with an OM return code of x'02000004', reason code x'00001000' and reason text "Command timed out" and **QUERY MEMBER TYPE(IMS) SHOW(STATUS)** shows no IMS in an online change state, the import worked, but the command timeout value was not long enough to get the response. If **QUERY MEMBER TYPE(IMS) SHOW(STATUS)** shows IMSs in an online change state, the command might have timed out because an SCI was down. Run the **QUERY IMSPLEX SHOW(STATUS)** command to see the IMSplex address spaces to determine whether SCI is down.

If SCI goes down after the directory was successfully updated, the import is committed, the directory update cannot be backed out, and message DFS4898E **IMPORT DEFN SOURCE(CATALOG) FAILED** is issued. If one or more IMSs are still in an online change state, bring SCI back up and run the **IMPORT DEFN SOURCE(CATALOG)** command again to the command master of the failing import to finish up the import.

If the command master of the failing import abended, another IMS in the IMSplex takes over processing the import and another **IMPORT** command to finish the import is not needed. If none of the IMSs are in an online change state, then the import was committed and no action is required. If an IMS is down before the **IMPORT** command is run, the **IMPORT** command succeeds with a warning return code and the IMS synchronizes itself with the directory when it comes back up. If a non-master IMS goes down during the **IMPORT** command processing, the **IMPORT** works and the IMS synchronizes itself with the directory when it comes back up.

The value of the ACBSHR= parameter that is in effect on the command master IMS system can affect whether the other IMS systems in the IMSplex process an **IMPORT DEFN SOURCE(CATALOG)** command.

- If ACBSHR=Y is specified in the command master, the **IMPORT DEFN SOURCE(CATALOG)** command is processed by all IMS systems in the IMSplex that specify ACBSHR=Y and any IMS systems that specify ACBSHR=N, if they are specified on the ROUTE parameter when the command is issued. For IMS systems that specify ACBSHR=N, the **IMPORT** command succeeds only if the IMS systems have pending ACB changes in the IMS catalog instance that they use.
- If ACBSHR=N is specified on the command master, the command is processed by the command master and by any IMS systems that also specify ACBSHR=N and are specified on the ROUTE parameter. The command is rejected by IMS systems that specify ACBSHR=Y.

The IMS system that serves as the command master is selected by IMS from the IMS systems to which the **IMPORT DEFN** command was routed.

When the FOR(IMSID()) option is specified, you must route the command to one of the IMS systems that are specified on the FOR(IMSID()) keyword.

Use the UPDATEPSB option when 64-bit storage pools are enabled, IMS loads the old version of the non-resident PSBs into 64-bit storage and mark them as refresh pending on IMS systems that share the directory data sets but are not included on the FOR(IMSID()) keyword. For dynamic option (DOPT) PSBs and for IMS systems without 64-bit storage pools enabled, the effect of the UPDATEPSB option is no different than issuing the IMPORT DEFN SOURCE(CATALOG) command without OPTION(UPDATEPSB) specified.

The previous effects of the UPDATEPSB option also apply to the FOR(IMSID()) keyword without OPTION() keyword specified.

The IMS systems that are not specified in the FOR(IMSID()) keyword when the UPDATEPSB option is specified do not process the IMPORT command so do not reload their in-memory PSB definitions after the modified PSB definitions are imported into the IMS directory. However, after command processing completes, if an IMS system that was not specified on the command is required to reload its in-memory PSB definition from the IMS directory for any other reason, the modified PSB definition will become the active PSB definition in that IMS system.

Usually, the IMS systems that are excluded from the UPDATEPSB option continue to use the original, in-memory PSB definitions until either the IMPORT DEFN SOURCE(CATALOG) OPTION(REFRESHPSB) command is issued for the IMS system or the IMS system is restarted. In-memory PSB definitions that are prevented from reloading when the UPDATEPSB option is specified have a *refresh-pending* (REFP) status in the IMPORT command response.

To activate the PSB modifications in an IMS system and remove the PSBs refresh-pending status, issue the IMPORT DEFN SOURCE(CATALOG) OPTION(REFRESHPSB) command with the ID of the IMS system specified on the FOR(IMSID()) keyword. The REFRESHPSB option reloads all PSB definitions that have a refresh-pending status in the IMS system.

## Output fields

In addition to the message, command response output is also returned in XML tag structure. The following table shows the **IMPORT** response output fields. The columns in the table are as follows:

### Short label

Contains the short label that is generated in the XML output.

### Long label

Contains the long label that is generated in the XML output.

### Keyword

Identifies keyword on the command that caused the field to be generated. N/A (not applicable) appears for output fields that are always returned. The value *error* appears for output fields that are returned only when an error occurs.

### Meaning

Provides a brief description of the output field.

Table 334. Output fields for the IMPORT command

| Short label | Long label | Keyword | Meaning   |
|-------------|------------|---------|---|
| ADD         | ADD        |         | The listed DBD or PSB was added as new to the IMS directory data set.<br><br>This output field is displayed only if it applies to one or more DBDs or PSBs. |

Table 334. Output fields for the IMPORT command (continued)

| Short label | Long label | Keyword      | Meaning  |
|-------------|------------|--------------|--|
| CATS        | CATSHR     |              | <p><b>Y</b></p> <p>The directory data sets are shared by IMS in the plex with ACBSHR=Y specified and with the same catalog alias specified.</p> <p><b>N</b></p> <p>The directory data sets is accessed by this IMS only.</p>   |
| CC          | CC         | N/A          | Completion code.   |
| CCTXT       | CCText     | <i>error</i> | Completion code text that briefly explains the meaning of the nonzero completion code.   |
| CHG         | CHNG       |              | <p>The listed DBD or PSB was successfully modified in the IMS directory data sets.</p> <p>This output field is displayed only if it applies to one or more DBDs or PSBs.</p>   |
| CPY         | COPY       |              | <p>The listed DBD or PSB was added to the IMS directory data set, but cannot be used until its runtime control block is created in the online IMS system by either a CREATE DB or a CREATE PGM command.</p> <p>This output field is displayed only if it applies to one or more DBDs or PSBs.</p>  |
| DBD         | DBDName    |              | Name of the DBD acted upon during IMPORT command processing.   |
| DLT         | DLET       |              | <p>The listed DBD or PSB was removed from the IMS directory data set because updates to another DBD removed the last or only logical relationship that required it.</p> <p>This output field is displayed only if it applies to one or more DBDs or PSBs.</p>  |
| ERRT        | ErrorText  |              | Additional information about errors.   |
| LSTT        | LclStat    |              | <p>NO-ASSOCIATED-PSB-FOUND-IN-STAGE</p> <p>You can use the OPTION(NOCHECK) parameter to import changed database resources that do not require PSBs to be rebuilt by using the DFS3UACB utility with BLDPSB=NO parameter or DDL ALTER.</p> <p>When the OPTION(NOCHECK) is specified on the IMPORT DEFN SOURCE(CATALOG) command, the IMPORT command reports any changed DBD when its associated PSBs are not found in the staging directory by returning a status of "NO-ASSOCIATED-PSB-FOUND-IN-STAGE".</p> |

Table 334. Output fields for the IMPORT command (continued)

| Short label | Long label | Keyword | Meaning   |
|-------------|------------|---------|---|
| PHST        | ErrPhase   |         | <p>A phase where an error occurred:</p> <p><b>OLCPREPF</b><br/>The process failed at prepare phase. The process is aborted.</p> <p><b>OLCCMT1F</b><br/>The process failed at commit phase 1. The process is aborted.</p> <p><b>OLCCMT2F</b><br/>The process failed at commit phase 2. The process is aborted.</p> <p><b>OLCCMT3F</b><br/>The process failed at commit phase 3. The process is aborted.</p> <p><b>OLCCMT4F</b><br/>The process failed at commit phase 4. The process reached a commit point.</p> |
| MBR         | MbrName    | N/A     | IMSplex member that built the output line.  |
| PSB         | PSBName    |         | Name of the imported PSB.   |
| RFP         | REFP       |         | <p>This IMS system is not yet using the most current version of the PSB that is in the IMS directory data set. To activate the most current version of the PSB in this IMS system, issue IMPORT DEFN SOURCE(REFRESHPSB) FOR(<i>this_ims</i>).</p> <p>This output field is displayed only if it applies to one or more DBDs or PSBs.</p>   |
| RFS         | RFSH       |         | <p>The listed DBD or PSB was successfully imported into the IMS directory data set. The only difference between the imported version and the previous version is the timestamp.</p> <p>This output field is displayed only if it applies to one or more DBDs or PSBs.</p>   |

## Return and reason codes

The following table includes the return and reason codes and a brief explanation of the codes. The return or reason code returned for the command might also indicate an error from a CSL request.

Table 335. Return and reason codes for the IMPORT command

| Return code | Reason code | Meaning   |
|-------------|-------------|---|
| X'00000008' | X'0000203C' | The command contains an invalid keyword parameter value.        |
| X'00000008' | X'00002004' | Invalid command keyword or invalid command keyword combination. |
| X'00000008' | X'00002008' | Insufficient number of keywords.                                |
| X'00000008' | X'00002009' | Multiple values for same attribute.                             |

Table 335. Return and reason codes for the IMPORT command (continued)

| Return code | Reason code | Meaning  |
|-------------|-------------|--|
| X'00000008' | X'00002028' | The command contains an invalid keyword.   |
| X'00000008' | X'00002176' | The Command (CMD) master was not provided.<br>If OPTION(UPDATEPSB) is specified, the IMS command master must be included in the FOR(IMSID(imsid)) list.  |
| X'00000008' | X'00002177' | The Command (CMD) master was provided.<br>If OPTION(REFRESHPSB) is specified, the IMS command master must not be included in the FOR(IMSID(imsid)) list.   |
| x'00000008' | x'00002178' | The IMPORT command was routed to an IMS that was not the command master of the previous IMPORT command that failed after the directory was successfully updated and the import was committed, but not finished.<br><br>To finish the report, the IMPORT command must be routed to the IMS that was the IMPORT command master of the IMPORT command that failed. If the previous import command master abended, another IMS in the IMSplex takes over processing the import and no second IMPORT command is needed. |
| X'00000008' | x'00002133' | Reason code x'00002133' means that the IMPORT DEFN SOURCE(CATALOG) command is not processed because one or more DBD or PSB ACBs names (or both) were specified with the NAME keyword, in addition to a NAME of *. If NAME(*) is specified, the asterisk must be the only NAME parameter.   |
| X'0000000C' | X'00003000' | Command was successful for some resource definitions but failed for others.  |
| X'00000010' | X'00004100' | Resource structure is full.  |
| X'00000010' | X'00004104' | No RM address space.   |
| X'00000010' | X'00004108' | No SCI address space.  |
| X'00000010' | X'0000400C' | Command is not valid on the XRF alternate.   |
| X'00000010' | X'00004018' | No resource structure exists, or resource structure is not available.  |
| X'00000010' | X'0000401C' | Command is not valid on the FDBR region.   |
| X'00000010' | X'00004120' | Online change phase is in progress.  |
| X'00000010' | X'00004124' | The <b>IMPORT</b> command is rejected, because a process of a similar type is in progress. Possible commands in progress are <b>/DISPLAY MODIFY, CREATE DB, or DELETE DB</b> commands. Wait until the other process completes and issue the <b>IMPORT</b> command again.   |
| X'00000010' | X'00004490' | The <b>IMPORT</b> command is rejected because the catalog database is not available. Either a <b>/DBR</b> command or the <b>UPD DB STOP (ACCESS)</b> command was issued against the catalog database or catalog partitions (or both) except in the case when the catalog database itself is being changed.   |
| X'00000010' | X'00004509' | RM data version is lower than the IMS data version.  |

Table 335. Return and reason codes for the **IMPORT** command (continued)

| Return code | Reason code | Meaning   |
|-------------|-------------|---|
| X'00000014' | X'00005000' | The <b>IMPORT</b> command was terminated, because <b>IMODULE GETSTOR</b> storage could not be obtained. |
| X'00000014' | X'00005004' | <b>DFSOCMD</b> response buffer could not be obtained.   |
| X'00000014' | X'00005008' | <b>DFSPPOOL</b> storage could not be obtained.  |
| X'00000014' | X'0000500C' | <b>AWE</b> could not be obtained.   |
| X'00000014' | X'00005010' | Unable to obtain latch.   |
| X'00000014' | X'00005018' | Unable to obtain a 64-bit buffer.   |
| X'00000014' | X'00005100' | <b>RM</b> request error.  |
| X'00000014' | X'00005108' | <b>SCI</b> request error.   |
| X'00000014' | X'00005FFF' | The <b>IMPORT</b> command could not be processed because of an internal error.                          |
| X'0000000C' | X'00003004' | No requests were successful.  |

Errors unique to the processing of this command are returned as completion codes. The following table includes an explanation of the completion codes.

## Completion codes

Table 336. Completion codes for the **IMPORT** command

| Completion code | Completion code text               | Meaning   |
|-----------------|------------------------------------|---|
| 0               |                                    | Command completed successfully for resource or descriptor definition.   |
| 1               | COMMAND NOT APPLICABLE TO THIS IMS | The <b>IMPORT DEFN SOURCE(CATALOG)</b> command does not apply to this IMS.  |
| 2               | COMMAND NOT ATTEMPTED BY THIS IMS  | The <b>IMPORT DEFN SOURCE(CATALOG)</b> command was not attempted by this IMS for one of the following reasons: <ul style="list-style-type: none"> <li>The <b>IMPORT DEFN SOURCE(CATALOG)</b> command master encountered an error and did not direct this IMS to process the <b>IMPORT DEFN SOURCE(CATALOG)</b> command.</li> <li>The <b>IMPORT DEFN SOURCE(CATALOG)</b> command master rejected the command because one or more IMS systems are down. The <b>IMPORT DEFN SOURCE(CATALOG)</b> command master did not direct this IMS to process the command.</li> <li>The <b>IMPORT DEFN SOURCE(CATALOG)</b> command was specified with <b>FOR(IMSID())</b> with no option, or with <b>OPTION(REFRESHPSB)</b> or <b>OPTION(UPDATEPSB)</b>, and this IMS was not specified in the <b>FOR(IMSID())</b>.</li> </ul> |
| 3               | IMS ALREADY IN REQUESTED OLC STATE | This IMS already processed the <b>IMPORT DEFN SOURCE(CATALOG)</b> command.  |

Table 336. Completion codes for the **IMPORT** command (continued)

| Completion code | Completion code text             | Meaning  |
|-----------------|----------------------------------|--|
| 4               | OLC PHASE INCOMPLETE ON THIS IMS | The <b>IMPORT</b> DEFN SOURCE(CATALOG) command is incomplete on this IMS. Look for other nonzero completion codes in the command output to determine why command processing is incomplete.   |
| 5               | OLC COMPLETE, SOME MBRS UNUSABLE | The <b>IMPORT</b> DEFN SOURCE(CATALOG) command is complete; however, during internal commit processing after the IMS list was updated in the IMS directory, an error was encountered and one or more ACBs that were added or changed are unusable.   |
| 10              | NO RESOURCES FOUND               | The DBD or PSB name is invalid, or the wildcard name does not match any DBD or PSB names in the staging directory.   |
| 17              | ANOTHER CMD IN PROGRESS          | <p>Another <b>IMPORT</b> command or an <b>OLC</b> command is in progress.</p> <p>If the previous <b>IMPORT</b> command did not complete and IMS terminated after the message CSL2200I CLIENT <i>clientname</i> INITIATED PROCESS DFSOLC was shown but the message CSL2200I CLIENT <i>clientname</i> TERMINATED PROCESS DFSOLC was not issued, the next <b>IMPORT</b> command can result in this error because the process in the Resource Manager (RM) was not cleaned up during the IMS restart or by another IMS sharing the IMS catalog.</p> <p>In a single RM environment, you can stop RM and restart RM, or you can shut down IMS and restart IMS to clean up and terminate the RM process so that the next <b>IMPORT</b> command runs successfully.</p> <p>In a multi-RM environment, you must shut down IMS and restart IMS to clean up and terminate the RM process so that the next <b>IMPORT</b> command runs successfully.</p> |
| 1D              | XRF TAKEOVER IS IN PROGRESS      | The <b>IMPORT</b> DEFN SOURCE(CATALOG) command cannot be processed because a takeover is in progress.  |



Table 336. Completion codes for the IMPORT command (continued)

| Completion code | Completion code text           | Meaning   |
|-----------------|--------------------------------|---|
| 32              | NOT ALLOWED FOR AN MSDB        | <p>The IMPORT command cannot be processed because one of the resources that is being imported from the staging directory is an MSDB.</p> <p>If the IMPORT command that is being processed does not include the NAME keyword, the command terminates on the first error, and the command output includes only the resources processed until the error.</p> <p>If the IMPORT command that is being processed includes the NAME keyword, all the resources that are associated with the name or names that are specified on the IMPORT command are listed in the command output.</p> |
| 51              | NO RESOURCE STRUCTURE          | The resource structure is not available. The resource could not be registered with RM. The resource definition was not imported.  |
| 52              | RESOURCE STRUCTURE FULL        | The resource structure is full. The resource could not be registered with RM. The resource definition was not imported.   |
| 58              | IMS NOT REGISTERED TO RM       | IMS is not registered to RM.  |
| 60              | IMODULE GETMAIN storage error. |   |
| 61              | DFSBCB STORAGE ERROR           | DFSBCB storage error. Could not get storage for DDIR, PDIR, RCTE, or SMB control block. The resource or descriptor definition was not imported.   |
| 62              | HIOP storage error.            |   |
| 63              | WKAP storage error.            |   |
| 64              | GETSTOR STORAGE ERROR          | DFSPPOOL storage error. Could not get storage from the CMDP pool. The resource or descriptor was not imported.  |
| 73              | PROGRAM SCHEDULED              | Program is scheduled.   |
| 77              | DEPENDENT REGIONS ACTIVE       | One or more dependent regions are scheduled against the database, or one or more areas are open. The DEDB cannot be updated.  |

Table 336. Completion codes for the **IMPORT** command (continued)

| Completion code | Completion code text      | Meaning   |
|-----------------|---------------------------|---|
| 80              | DATASET ERROR             | <p>Function (8 characters), ddname (8 characters), return code (8 bytes), and error detail (8 characters).</p> <p>Function can be one of the following:</p> <p><b>BLDL</b><br/>Data set BLDL error.</p> <p><b>BUSY</b><br/>The data set is busy. The detail contains the job name that has the data set.</p> <p><b>DIR</b><br/>Data set directory error.</p> <p><b>EMPTY</b><br/>Library is empty.</p> <p><b>ENQUEUE</b><br/>Data set enqueue error.</p> <p><b>EOF</b><br/>Data set end-of-file (EOF) error.</p> <p><b>OPEN</b><br/>Data set open error. Error detail can be 'DLS REG'.</p> <p><b>READ</b><br/>Data set read error.</p> <p><b>WRITE</b><br/>Data set write error.</p> <p>Ddname can be the DFSDIRC, the ddname of the IMS directory data set or DFSSTDI, the ddname of the staging data set of the IMS directory.</p> <p>Return code is the data set service return code.</p> <p>Reason code is the data set service reason code.</p> |
| 90              | INTERNAL ERROR            | An IMS internal error occurred. The definition was not imported.  |
| 91              | TIMEOUT ERROR             | An internal prepare phase, commit phase, or abort phase of the <b>IMPORT DEFN SOURCE (CATALOG)</b> command timed out before this IMS responded to the internal prepare or commit phase. The prepare phase or commit phase might have succeeded on this IMS.   |
| 94              | RM REQUEST ERROR          | An RM request error occurred. The resource could not be registered with RM. The resource definition was not imported.   |
| B0              | RESOURCE DEFINITION ERROR | The resource exists as another resource type in the RM structure. The resource definition was not imported.   |

---

Table 336. Completion codes for the *IMPORT* command (continued)

---

| <b>Completion code</b> | <b>Completion code text</b> | <b>Meaning</b>  |
|------------------------|-----------------------------|---|
| B1                     | RESOURCE STATE ERROR        | <p>Resource type (8 characters), resource name (8 characters), error detail (16 characters).</p> <p>The resource name is the name of the resource as it is defined to IMS, such as the database name, the program name, or the transaction name.</p> <p>The error detail can be one of the following:</p> <p><b>AREA OPEN</b><br/>An area associated with the FP DEDB is open.</p> <p><b>AREA STARTED</b><br/>An area associated with the FP DEDB is started.</p> <p><b>DATABASE <i>dbname</i> ALTER INCOMPLETE</b><br/>Alter processing is not complete for a HALDB database. After alter processing completes, retry the <b>INITIATE OLC</b> command.</p> <p><b>DATABASE <i>dbname</i> STG TOO SMALL</b><br/>The <b>IMPORT DEFN SOURCE (CATALOG)</b> command cannot process the altered DDIR because there is not enough internal block storage.</p> <p>The lack of storage could be caused by the start of another HALDB alter operation after the <b>IMPORT</b> command reaches the commit phase.</p> <p>Retry the <b>IMPORT DEFN SOURCE (CATALOG)</b> command.</p> <p>Error details continued in next row.</p> |

---

---

Table 336. Completion codes for the *IMPORT* command (continued)

---

| Completion code | Completion code text                | Meaning   |
|-----------------|-------------------------------------|---|
| B1              | RESOURCE STATE ERROR<br>(continued) | <p><b>DBD ACTIVE</b><br/>A <b>/DBDUMP</b> command is active for the database.</p> <p><b>DBR ACTIVE</b><br/>A <b>/DBRECOVERY</b> command is active for the database.</p> <p><b>DBR NEEDED</b><br/>A <b>/DBRECOVERY</b> command is needed for the database resource. The <b>IMPORT DEFN SOURCE(CATALOG)</b> command was initiated to either change or delete one or more HALDB databases which have not been taken offline with a <b>/DBR</b> command.</p> <p>If the IMS catalog is enabled with an alias other than DFSC (the standard alias prefix), and the catalog databases have been modified with the <b>IMPORT DEFN SOURCE(CATALOG)</b> command, issue the <b>/DBR DB</b> command for the databases IMS1D000 and IMS1X000 instead of DFSCD000 and DFSCX000.</p> <p><b>DEP REGS ACTIVE</b><br/>Dependent regions using the FP DEDB are active.</p> <p>Error details are shown in next row.</p> |

---

Table 336. Completion codes for the *IMPORT* command (continued)

| Completion code | Completion code text                | Meaning  |
|-----------------|-------------------------------------|--|
| B1              | RESOURCE STATE ERROR<br>(continued) | <p>Error detail (continued):</p> <p><b>INTERNAL ERROR</b><br/>The resource control block is not found in the active IMS, or the resource control block exists. These are internal errors that should not occur.</p> <p><b>IN USE</b><br/>The resource is in use.</p> <p>A transaction has queuing in progress (either terminal input program-to-program switch).</p> <p>A database is in use.</p> <p><b>PSB SCHEDULED</b><br/>A program referencing a database to be changed or deleted is scheduled.</p> <p><b>QUEUEING</b><br/>Messages are queued to the transaction or program.</p> <p><b>SCHEDULED</b><br/>The named resource (a transaction or program to be changed or deleted, or a program referencing a database to be changed or deleted) is scheduled.</p> <p><b>SUSPENDED</b><br/>The transaction to be changed or deleted is on the suspend queue.</p> |
| B2              | IMS STATE ERROR                     | <p>IMS state error (32 characters). The IMS state can be one of the following:</p> <p><b>CHECKPOINT IN PROGRESS</b><br/>This IMS has checkpoint in progress.</p> <p><b>NOT-REACHABLE</b><br/>The online change phase is rejected because this IMS is NOT-REACHABLE. The SCI on the OS image where this IMS is active is down. Restart the SCI and reissue the <b>IMPORT DEFN SOURCE (CATALOG)</b> command.</p> <p><b>OLC ALREADY COMMITTED</b><br/>The internal online change phase of <i>IMPORT</i> command processing is rejected because online change is already committed.</p>  |

Table 336. Completion codes for the IMPORT command (continued)

| Completion code | Completion code text                                  | Meaning  |
|-----------------|---|--|
| B2              | IMS STATE ERROR<br>(continued)                        | <p>IMS state error (32 characters). The IMS state can be one of the following:</p> <p><b>OLC PHASE IN PROGRESS</b><br/>The IMPORT DEFN SOURCE(CATALOG) command is rejected because this IMS is processing either another IMPORT DEFN SOURCE(CATALOG) command or an online change request.</p> <p><b>RECOVERY IN PROGRESS</b><br/>The IMPORT DEFN SOURCE(CATALOG) command is rejected because the online recovery service is already in progress.</p> <p><b>RESOLVE DB INDOUBTS</b><br/>This IMS has DB indoubts. You must resolve the DB indoubts either by reconnecting the coordinator controller and IMS or by using an operator command.</p> <p><b>RESTART IN PROGRESS</b><br/>This IMS has restart in progress.</p> <p><b>RESTART NOT COMPLETE</b><br/>This IMS initialized before the IMPORT DEFN SOURCE(CATALOG) command was issued, but has not completed restart. The command is rejected as long as this IMS is in this state.</p> |
| D6              | DATABASE IN USE                                       | Database in use. The DEDB cannot be changed because the DEDB is in use in a region.  |
| E1              | DB MUST BE STOPPED AND OFFLINE                        | The database must be stopped and taken offline in order for the attribute to be changed. You might need to issue a <b>/DBR DB</b> command or an <b>UPDATE DB STOP (ACCESS)</b> command to stop the database and take it offline before issuing the <b>IMPORT DEFN</b> command.   |
| 120             | STAGING ACBLIB IS EMPTY                               | The IMPORT DEFN SOURCE(CATALOG) command failed.  |
| 121             | RESOURCE IN CMD HAS NO CHANGE                         | The IMPORT DEFN SOURCE(CATALOG) command failed.  |
| 122             | NOT ALL PSBS REBUILT FOR THIS DMB                     | The IMPORT DEFN SOURCE(CATALOG) command failed.  |
| 123             | STAGING LIBRARY LEVEL NOT COMPATIBLE WITH CURRENT IMS | The IMPORT DEFN SOURCE(CATALOG) command failed.  |
| 125             | NO PSB REBUILT  | During processing of the IMPORT DEFN SOURCE(CATALOG) command, IMS found existing PSB resources in the IMS directory that must be rebuilt before a modified DBD resource can be activated.  |

Table 336. Completion codes for the IMPORT command (continued)

| Completion code | Completion code text             | Meaning  |
|-----------------|----------------------------------|--|
| 137             | NO PSB FOR CHANGED DB IN STAGING | During processing of the IMPORT DEFN SOURCE(CATALOG) command, IMS does not find any associated PSBs rebuilt for the changed DBD resource in the staging directory.   |
| 1D0             | NOT DONE DUE TO ERROR            | The identified resource was not imported because an error occurred. Check for other completion codes that are greater than 4 to determine the cause of the error.  |
| 1F2             | DIRECTORY BLDL FAILED            | During processing of the <b>IMPORT DEFN SOURCE(CATALOG)</b> command, IMS encountered a BLDL error while reading the directory data sets.   |
| 1F3             | BAD ACB FORMAT IN DIRECTORY      | During processing of the IMPORT DEFN SOURCE(CATALOG) command, IMS encountered an ACB that contains a block with an unrecognized DBD or PSB format.   |
| 1F5             | OPEN DIRECTORY FAILED            | During processing of the IMPORT DEFN SOURCE(CATALOG) command, IMS was unable to open the IMS directory data set for update.<br><br>This is probably an internal error. Contact IBM Software Support.   |
| 1F6             | CANNOT IMPORT IMS SYSTEM RSC     | During processing of the IMPORT DEFN SOURCE(CATALOG) command, IMS encountered an ACB for the IMS catalog or another IMS system resource. The IMS catalog cannot be modified by using the IMPORT DEFN SOURCE(CATALOG) command.  |
| 1FB             | PSB NOT REBUILT                  | During processing of the IMPORT DEFN SOURCE(CATALOG) command, IMS found existing PSB resources in the IMS directory that must be rebuilt before a modified DBD resource can be activated.  |
| 1FC             | I/O ERROR READING DIRECTORY      | During processing of the IMPORT DEFN SOURCE(CATALOG) command, IMS was unable to read from the IMS directory.<br><br>Determine the cause of the error and restore or rebuild the IMS directory. After the IMS directory is recovered, reissue the IMPORT command.   |
| 1FD             | I/O ERROR READING STAGING        | During processing of the IMPORT DEFN SOURCE(CATALOG) command, IMS was unable to read from the staging data set of the IMS catalog.<br><br>Resubmit the resource changes to IMS by using either DDL or one of the IMS catalog populate utilities. After the changes are resubmitted to IMS, reissue the IMPORT command. |
| 1FE             | ADDED MBR NOT IN STAGING         | This is probably an internal error. Contact IBM Software Support.  |

Table 336. Completion codes for the IMPORT command (continued)

| Completion code | Completion code text                 | Meaning   |
|-----------------|--------------------------------------|---|
| 1FF             | REPLACED MEMBER NOT IN STAGING       | This is probably an internal error. Contact IBM Software Support.   |
| 227             | ERROR CLEANUP DIRECTORY              | IMPORT DEFN SOURCE(CATALOG) command processing attempted to clean up the directory data sets before initiating a new import activation process, but the cleanup process failed. Check the console for error messages and correct any errors before resubmitting the IMPORT command.   |
| 231             | DLET MBR NOT IN DIRECTORY            | During processing of the IMPORT DEFN SOURCE(CATALOG) command, IMS attempted to delete a resource from the IMS directory, but the resource was not found in the IMS directory.   |
| 235             | EMPTY STAGING DIRECTORY              | During processing of the IMPORT DEFN SOURCE(CATALOG) command, no resources were found to import in the staging data set.  |
| 236             | I/O ERROR UPDATING DIRECTORY         | During processing of the IMPORT DEFN SOURCE(CATALOG) command, IMS was unable to update the IMS directory.<br><br>This is probably an internal error. Contact IBM Software Support.  |
| 237             | I/O ERROR READING DFSIMSL            | During processing of the IMPORT DEFN SOURCE(CATALOG) command, IMS could not read the IMS list in the IMS directory. Either the directory data set is not available, or the IMS list member does not exist.<br><br>In the case where the directory data set is not available, resolve the I/O error and then try import again. |
| 238             | I/O ERROR WRITING DFSIMSR            | During processing of the IMPORT DEFN SOURCE(CATALOG) command, IMS could not update the resource list in the IMS directory.  |
| 23A             | I/O ERROR WRITING DFSIMSL            | During processing of the IMPORT DEFN SOURCE(CATALOG) command, IMS could not write to the list of IMS systems that share the IMS catalog in the IMS directory.   |
| 23C             | THIS IMS CATALOG IS NO LONGER SHARED | The ACBSHR specification for this IMS system changed from ACBSHR=Y to ACBSHR=N. When processing the IMPORT DEFN SOURCE(CATALOG) command, IMS no longer includes this IMS system in the global coordination of changes to a shared IMS catalog in the IMSplex.   |
| 23D             | DIRECTORY DATA SET FULL              | The IMPORT DEFN SOURCE(CATALOG) command failed because the directory data set was full. Run the catalog recovery utility to get more spaces for the data sets.  |



Table 336. Completion codes for the **IMPORT** command (continued)

| Completion code | Completion code text             | Meaning  |
|-----------------|----------------------------------|--|
| 23E             | STAGING BLDL FAILED              | During processing of the <b>IMPORT DEFN SOURCE(CATALOG)</b> command, IMS encountered a BLDL error while reading the staging data sets.   |
| 240             | IMSID NOT FOUND IN DFSIMSL       | During processing of the <b>IMPORT DEFN SOURCE(CATALOG)</b> command, an <b>imsid</b> provided in the <b>FOR(IMSID(imsid))</b> list does not exist in the <b>DFSIMSL</b> member of the IMS directory data set.  |
| 241             | DMB FOUND IN STAGING DATA SET    | During processing of the <b>IMPORT DEFN SOURCE(CATALOG)</b> , a non-GSAM <b>DMB</b> was found in the staging data set.   |
| 242             | NO RESOURCES IN REFRESH PENDING  | During processing the <b>IMPORT DEFN SOURCE(CATALOG) OPTION(REFRESHPSB)</b> no <b>PSBs</b> were found to refresh.  |
| 243             | NO REFRESH PENDING AND NO UPDATE | During processing of the <b>IMPORT DEFN SOURCE(CATALOG) FOR(IMSID())</b> command with no <b>OPTION()</b> specified, no <b>PSBs</b> were found to be refreshed. The staging data set is empty and no <b>PSBs</b> were updated to the directory.   |
| 244             | STOW ERROR IN DIRECTORY DATA SET | During processing of the <b>IMPORT DEFN SOURCE(CATALOG)</b> command, an I/O error occurs when writing the directory of the IMS directory. The <b>IMPORT DEFN SOURCE(CATALOG)</b> command fails.  |
| 246             | OPEN STAGING DIRECTORY FAILED    | During processing of the <b>IMPORT DEFN SOURCE(CATALOG)</b> command, IMS was unable to open the IMS staging directory data set for update.   |
| 247             | DESERV FAILED                    | The <b>IMPORT DEFN SOURCE(CATALOG)</b> command failed issuing a z/OS <b>DESERV</b> request to retrieve system-managed directory entries ( <b>SMDE</b> ) for all members of the staging directory. The error text contains the module name that detected the error (8 characters) and the <b>DESERV</b> return code (8 characters). |
| 248             | CAT DBDS IN STG WITH OTHER RSCS  | During processing of the <b>IMPORT DEFN SOURCE(CATALOG)</b> , a catalog <b>DBD</b> was found in the staging data set with other resources. Other resources must be removed before a modified catalog <b>DBD</b> resource can be activated.   |
| 249             | DIRECTORY IS CLOSED              | The directory is closed due to an I/O error.   |
| 24A             | ESTAE SETUP ERROR                | <b>ESTAE</b> setup fails.  |

## Examples

### Example 1 for **IMPORT DEFN SOURCE(CATALOG)**

The following example shows the output after issuing the **IMPORT DEFN SOURCE(CATALOG)** command in a single IMS system.

TSO SPOC input:

```
IMPORT DEFN SOURCE(CATALOG)
```

TSO SPOC output:

| MbrName | Member | CC | CATSHR | DBDName  | PSBName | CHNG | DLET |
|---------|--------|----|--------|----------|---------|------|------|
| IMS1    | IMS1   | 0  | N      |          |         |      |      |
| IMS1    | IMS1   | 0  | N      | DEDBGS1A |         | Y    |      |
| IMS1    | IMS1   | 0  | N      | FPSI1ASA |         |      | Y    |
| IMS1    | IMS1   | 0  | N      |          | BMP255  | Y    |      |

OM API input:

```
CMD(IMPORT DEFN SOURCE(CATALOG))
```

OM API output:

```
<?xml version="1.0"?>
<!DOCTYPE imsout SYSTEM "imsout.dtd">
<imsout>
<ctl>
<omname>OM10M </omname>
<omvsn>1.7.0</omvsn>
<xmlvsn>20 </xmlvsn>
<statime>2015.276 06:24:56.083208</statime>
<stotime>2015.276 06:24:56.836962</stotime>
<staseq>CFA3D9F7A8308DE5</staseq>
<stoseq>CFA3D9F860362863</stoseq>
<rqsttkn1>USRT011 10232456</rqsttkn1>
<rc>00000000</rc>
<rsn>00000000</rsn>
</ctl>
<cmd>
<master>IMS1 </master>
<userid>USRT011 </userid>
<verb>IMP </verb>
<kwd>DEFN </kwd>
<input>IMPORT DEFN SOURCE(CATALOG) </input>
</cmd>
<cmdsphdr>
<hdr slbl="MBR" llbl="MbrName" scope="LCL" sort="n" key="0"
  scroll="yes" len="8" dtype="CHAR" align="left" />
<hdr slbl="IMSMBR" llbl="Member" scope="LCL" sort="a" key="4"
  scroll="no" len="8" dtype="CHAR" align="left" />
<hdr slbl="CC" llbl="CC" scope="LCL" sort="n" key="0" scroll="yes"
  len="4" dtype="INT" align="right" />
<hdr slbl="CCTXT" llbl="CCText" scope="LCL" sort="n" key="0"
  scroll="yes" len="*" dtype="CHAR" align="left" skipb="yes" />
<hdr slbl="CATS" llbl="CATSHR" scope="LCL" sort="n" key="0"
  scroll="yes" len="1" dtype="CHAR" align="left" skipb="yes" />
<hdr slbl="RSC" llbl="RSCName" scope="LCL" sort="a" key="3" scroll="no"
  len="8" dtype="CHAR" align="left" skipb="yes" />
<hdr slbl="DBD" llbl="DBDName" scope="LCL" sort="a" key="2" scroll="no"
  len="8" dtype="CHAR" align="left" skipb="yes" />
<hdr slbl="PSB" llbl="PSBName" scope="LCL" sort="a" key="1" scroll="no"
  len="8" dtype="CHAR" align="left" skipb="yes" />
<hdr slbl="ADD" llbl="ADD" scope="LCL" sort="n" key="0" scroll="yes"
  len="1" dtype="CHAR" align="left" skipb="yes" />
<hdr slbl="CHG" llbl="CHNG" scope="LCL" sort="n" key="0" scroll="yes"
  len="1" dtype="CHAR" align="left" skipb="yes" />
<hdr slbl="CPY" llbl="COPY" scope="LCL" sort="n" key="0" scroll="yes"
  len="1" dtype="CHAR" align="left" skipb="yes" />
<hdr slbl="RFS" llbl="RFSH" scope="LCL" sort="n" key="0" scroll="yes"
  len="1" dtype="CHAR" align="left" skipb="yes" />
<hdr slbl="DLT" llbl="DLET" scope="LCL" sort="n" key="0" scroll="yes"
  len="1" dtype="CHAR" align="left" skipb="yes" />
</cmdsphdr>
<cmdsdata>
<rsp>MBR(IMS1 ) IMSMBR(IMS1 ) CC( 0) CATS(N) </rsp>
<rsp>MBR(IMS1 ) IMSMBR(IMS1 ) CC( 0) CCTXT() CATS(N)
  DBD(DEDBGS1A) CHG(Y) </rsp>
<rsp>MBR(IMS1 ) IMSMBR(IMS1 ) CC( 0) CCTXT() CATS(N)
  DBD(FPSI1ASA) DLT(Y) </rsp>
<rsp>MBR(IMS1 ) IMSMBR(IMS1 ) CC( 0) CCTXT() CATS(N) PSB(BMP255)
  ) CHG(Y) </rsp>
```

```
</cmdrspdata>
</imsout>
```

### Example 2 for IMPORT DEFN SOURCE(CATALOG) in a shared ACB environment (ACBSHR=Y)

The following example shows a scenario in which the processing of the IMPORT DEFN SOURCE(CATALOG) command fails in a multisystem environment where three IMS systems, IMS1, IMS2, and IMS3, share the ACBs in the IMS directory data set of the IMS catalog. In this scenario, IMS1, the command master, abends during phase 1 of commit processing. Later, IMS2 also abends.

The following example is of the QUERY MEMBER command that is routed to all IMS systems before IMS1, the command master, abends. The QUERY MEMBER command output shows that the processing of an IMPORT DEFN SOURCE(CATALOG) is in progress at phase 1 of commit processing in IMS1 and at phase 0 in both IMS2 and IMS3.

TSO SPOC input:

```
QUERY MEMBER TYPE(IMS) SHOW(ALL)
```

TSO SPOC output:

```
Response for: QUERY MEMBER TYPE(IMS) SHOW(ALL)
MbrName  CC Type  Status  LclAttr          LclStat
IMS1     0 IMS    IMPCMD
IMS1     0 IMS    IMPCMD  GBLOLC,NO-STM,DIRECTORY  IMPPHC1I,SECCMD,SECMSG
IMS2     0 IMS    IMPCMD
IMS2     0 IMS    IMPCMD  GBLOLC,NO-STM,DIRECTORY  IMPPHC0I,SECCMD,SECMSG
IMS3     0 IMS    IMPCMD
IMS3     0 IMS    IMPCMD  GBLOLC,NO-STM,DIRECTORY  IMPPHC0I,SECCMD,SECMSG
```

The following QUERY command is routed to all IMS systems and shows that IMS1, the command master for the IMPORT DEFN SOURCE(CATALOG) command, abended during phase 1 of commit processing. Because the commit point was not reached, the import is aborted.

Both IMS2 and IMS3 attempt to take over import processing to abort the updates that were made to the directory data sets and to cleanup RM process information.

TSO SPOC output:

```
Response for: QUERY MEMBER TYPE(IMS) SHOW(ALL)
MbrName  CC Type  Status  LclAttr          LclStat
IMS2     0 IMS    IMPCMD,IMPPHC1T,IMPABORT
IMS2     0 IMS    IMPCMD,IMPPHC1T,IMPABORT  GBLOLC,NO-STM,DIRECTORY  SECCMD,SECM
IMS3     0 IMS    IMPCMD,IMPPHC1T,IMPABORT
IMS3     0 IMS    IMPCMD,IMPPHC1T,IMPABORT  GBLOLC,NO-STM,DIRECTORY  SECCMD,SECM
```

In the following example, the QUERY MEMBER command was routed to all systems, but now IMS2, which became the new command master after the abend of IMS 1, also abended. IMS2 abended before it finished cleaning up the import process. IMS 3 cleans up its own local system, but not the directory or RM blocks, because IMS3 did not succeed in taking over processing after the first abend of IMS1.

```
Response for: QUERY MEMBER TYPE(IMS) SHOW(ALL)
MbrName  CC Type  Status  LclAttr          LclStat
IMS3     0 IMS    IMPCMD,IMPPHC1F,IMPABORT
IMS3     0 IMS    IMPCMD,IMPPHC1F,IMPABORT  GBLOLC,NO-STM,DIRECTORY  SECCMD,SECM
```

To resolve import processing after the failures, the IMPORT DEFN SOURCE(CATALOG) command is issued again on IMS3. The new import command cleans up the prior import process before it attempts to import the resources again. After IMS1 and IMS2 are restarted, they will pick up the changed resources from the directory and will not process any IMPORT log records.

```
Response for: IMPORT DEFN
SOURCE(CATALOG)
MbrName  Member  CC CText          ErrorText          ErrPhase CATSHR
DBDName  PSBName CHNG
-----
IMS3     IMS1    4 IMS STATE ERROR ABENDED
```

```

Y
IMS3      IMS2      4 IMS STATE ERROR ABENDED
Y
IMS3      IMS3      0
Y
IMS3      IMS3      0
DBOHIDK5      Y
IMS3      IMS3      0
DBVHDJ05      Y
IMS3      IMS3      0
D2XHDJ05      Y
IMS3      IMS3      0
D2XHIDK5      Y
IMS3      IMS3      0
Y           PSBEJK05 Y

```

**Example 3 for the OPTION() keyword of the IMPORT DEFN SOURCE(CATALOG) command**

The following example shows a scenario in which a PSB is activated in only a subset of IMS systems in an IMSplex by issuing a sequence of IMPORT DEFN SOURCE(CATALOG) commands with OPTION(UPDATEPSB) or OPTION(REFRESHPSB) specified.

There are three IMS systems, IMS1, IMS2, and IMS3, in the IMSplex and they share the ACBs in the IMS directory data set of the IMS catalog.

The following command with OPTION(UPDATEPSB) activates PSB DDLTFPE1 on IMS1 only, which is also the command master. On IMS2 and IMS3, the PSB is placed in a refresh-pending state.

TSO SPOC input:

```
IMPORT DEFN SOURCE(CATALOG) OPTION(UPDATEPSB) FOR(IMSID(IMS1))
```

The log output for the preceding command shows that IMS1 is the command master.

```

Log for:  IMPORT DEFN SOURCE(CATALOG) OPTION(UPDATEPSB) FOR(IMSID(IMS1))

IMSplex . . . . . : PLEX1
Routing . . . . . : IMS1
Start Time. . . . : 2016.264 15:18:59.26
Stop Time . . . . : 2016.264 15:18:59.86
Return code . . . : 00000000
Reason code . . . : 00000000
Reason text . . . :
Command master. . : IMS1

```

The TSO SPOC output shows that the active PSB on IMS1 changed:

```

Response for: IMPORT DEFN SOURCE(CATALOG) OPTION(UPDATEPSB) FOR(IMSID(IMS1))
MbrName  Member  CC CATSHR PSBName  CHNG REFP
-----
IMS1     IMS1     0 Y
IMS1     IMS1     0 Y      DDLTFPE1 Y
IMS1     IMS2     0 Y      DDLTFPE1 Y
IMS1     IMS3     0 Y      DDLTFPE1 Y

```

Next, the IMPORT command is issued with OPTION(REFRESHPSB) and FOR(IMSID(IMS2)) specified to activate the PSB on IMS2. On IMS3, the PSB remains in a refresh-pending state. On IMS1, the refresh request is not applicable because the PSB is already active. The command response also shows that the refresh is not applicable for IMS1 (as it was the command master) and that the command was not attempted for IMS3 as it was not in the FOR() clause.

TSO SPOC input:

```
IMPORT DEFN SOURCE(CATALOG) OPTION(REFRESHPSB) FOR(IMSID(IMS2))
```

The log output for the preceding command shows that IMS1 is still the command master.

```
Log for:  IMPORT DEFN SOURCE(CATALOG) OPTION(REFRESHPSB) FOR(IMSID(IMS2))
```

```

IMSpIex . . . . . : PLEX1
Routing . . . . . : IMS1
Start Time. . . . : 2016.264 15:19:57.28
Stop Time . . . . : 2016.264 15:19:57.67
Return code . . . : 02000004
Reason code . . . : 00001014
Reason text . . . : At least one request completed with warning/s.
Command master. . : IMS1

```

The TSO SPOC output shows that the active PSB on IMS2 changed, the command was not applicable to IMS1, and not processed by IMS3:

```

Response for: IMPORT DEFN SOURCE(CATALOG) OPTION(REFRESHPSB) FOR(IMSID(IMS2))
MbrName Member CC CCText CATSHR PSBName CHNG
-----
IMS1 IMS1 2 CMD NOT ATTEMPTED BY THIS IMS
IMS1 IMS3 2 CMD NOT ATTEMPTED BY THIS IMS
IMS1 IMS2 0 Y DDLTFPE1 Y

```

#### **Example 4 for the OPTION() keyword of the IMPORT DEFN SOURCE(CATALOG) command**

Import two database resources, DH41SK01 and DX41SK01, built using DFS3UACB with BLDPSB=NO in an IMSplex of IMS1 and IMS2.

TSO SPOC input:

```
IMPORT DEFN SOURCE(CATALOG) OPTION(NOCHECK)
```

The log output for the preceding command shows IMS2 is the command master.

```

Log for: IMP DEFN SOURCE(CATALOG) OPTION(NOCHECK)

IMSpIex . . . . . : PLEX1
Routing . . . . . :
Start Time. . . . : 2019.151 20:26:14.17
Stop Time . . . . : 2019.151 20:26:14.95
Return code . . . : 00000000
Reason code . . . : 00000000
Reason text . . . :
Command master. . : IMS2

```

The TSO SPOC output shows DB changes for DH41SK01 and DX41SK01 are imported successfully without their associated PSBs found in the staging directory.

```

Response for: IMP DEFN SOURCE(CATALOG) OPTION(NOCHECK)
MbrName Member CC CATSHR DBDName CHNG LclStat
-----
IMS2 IMS1 0 Y
IMS2 IMS2 0 Y
IMS2 IMS2 0 Y DH41SK01 Y NO-ASSOCIATED-PSB-FOUND-IN-STAGE
IMS2 IMS2 0 Y DX41SK01 Y NO-ASSOCIATED-PSB-FOUND-IN-STAGE

```

#### **Example 5 for the IMPORT DEFN SOURCE(CATALOG) FOR(IMSID()) command**

The following example shows a scenario in which a PSB is activated in only one IMS at a time in an IMSplex by issuing a sequence of IMPORT DEFN SOURCE(CATALOG) FOR(IMSID()) commands without the OPTION keyword. The FOR(IMSID()) keyword without the OPTION keyword is equivalent to OPTION(REFRESHPSB) and OPTION(UPDATEPSB).

There are three IMS systems in an IMSplex: IMS1, IMS2, and IMS3. These systems share the ACBs in the IMS directory data set of the IMS catalog.

The following command with FOR(IMSID()) activates PSBs PBAJK01 and PBAJK02 on IMS1 only, which is also the command master. On IMS2 and IMS3, the PSB is placed in a refresh-pending state.

The overall return and reason code are zero because all three IMSs took some action to process the command. The PSBs were activated on IMS and set as pending refresh on IMS2 and IMS3.

TSO SPOC input, routed to IMS1:

```
IMPORT DEFN SOURCE(CATALOG) FOR(IMSID(IMS1))
```

The log output for the preceding command shows that IMS1 is the command master.

```
Log for:  IMPORT DEFN SOURCE(CATALOG) FOR(IMSID(IMS1))

IMSplex . . . . . : PLEX1
Routing . . . . . : IMS1
Start Time . . . . : 2020.268 11:48:55.56
Stop Time . . . . . : 2020.268 11:48:55.93
Return code . . . . : 00000000
Reason code . . . . : 00000000
Reason text . . . . :
Command master. . . : IMS1
```

The TSO SPOC output shows that the PSB was successfully changed on IMS1 and needs refresh on IMS2 and IMS3:

```
Response for:  IMPORT DEFN SOURCE(CATALOG) FOR(IMSID(IMS1))
MbrName  Member  CC CATSHR PSBName  CHNG REFP
-----
IMS1     IMS1       0 Y
IMS1     IMS1       0 Y      PBAJK01  Y
IMS1     IMS2       0 Y      PBAJK01  Y
IMS1     IMS3       0 Y      PBAJK01  Y
IMS1     IMS1       0 Y      PBAJK02  Y
IMS1     IMS2       0 Y      PBAJK02  Y
IMS1     IMS3       0 Y      PBAJK02  Y
```

Next, the IMPORT command is issued with FOR(IMSID(IMS2)) that is specified to activate the PSB on IMS2. This command must be routed to IMS2 because the command master must be included in the FOR(IMSID()) list. On IMS1, the refresh request is not done because the changed PSB is already active. On IMS2, the PSBs are refreshed. On IMS3, the refresh request was not done because IMS3 was not included in the FOR(IMSID()) clause and the PSBs remain in a refresh-pending state.

TSO SPOC input, routed to IMS2:

```
IMPORT DEFN SOURCE(CATALOG) FOR(IMSID(IMS2))
```

The TSO SPOC output shows that the active PSB on IMS2 changed; the command was not done on IMS1 and IMS3.

```
Log for:  IMPORT DEFN SOURCE(CATALOG) FOR(IMSID(IMS2))
IMSplex . . . . . : PLEX1
Routing . . . . . : IMS2
Start Time . . . . : 2020.268 11:48:56.61
Stop Time . . . . . : 2020.268 11:48:56.81
Return code . . . . : 02000004
Reason code . . . . : 00001014
Reason text . . . . : At least one request completed with warning/s.
Command master. . . : IMS1

Response for:  IMPORT DEFN SOURCE(CATALOG) FOR(IMSID(IMS2))
MbrName  Member  CC CCText  CATSHR PSBName  CHNG
-----
IMS2     IMS1     2 CMD NOT ATTEMPTED BY THIS IMS Y
IMS2     IMS2     0 Y
IMS2     IMS3     2 CMD NOT ATTEMPTED BY THIS IMS Y
IMS2     IMS2     0 Y      PBAJK01  Y
IMS2     IMS2     0 Y      PBAJK02  Y
```

Finally, the IMPORT command is issued with FOR(IMSID(IMS3)) that is specified to activate the PSB on IMS3. This command must be routed to IMS3 because the command master must be included in the FOR(IMSID()) list. On IMS1 and IMS2, the refresh request is not done because the changed PSB is already active.

TSO SPOC input, routed to IMS3:

```
IMPORT DEFN SOURCE(CATALOG) FOR(IMSID(IMS3))
```

The TSO SPOC output shows that the PSB is changed on IMS3 and not done on IMS1 and IMS2 because the PSBs were already activated on IMS1 and IMS2.

```

Response for: IMPORT DEFN SOURCE(CATALOG) FOR(IMSID(IMS3))
MbrName  Member      CC CCText                CATSHR PSBName  CHNG
-----
IMS3     IMS1             2 CMD NOT ATTEMPTED BY THIS IMS Y
IMS3     IMS2             2 CMD NOT ATTEMPTED BY THIS IMS Y
IMS3     IMS3             0                                Y
IMS3     IMS3             0                                Y      PBAJK01  Y
IMS3     IMS3             0                                Y      PBAJK02  Y

```

### Related concepts

[How to interpret CSL request return and reason codes \(System Programming APIs\)](#)

### Related reference

[“Command keywords and their synonyms” on page 59](#)

All IMS command keywords and their synonyms, as well as keywords supported by the OM API, are listed. The list covers command keywords for the OM command processing clients such as IMS, ODBM, IMSCON, and RM.

## IMPORT DEFN SOURCE(REPO | RDDDS) command

Use the **IMPORT DEFN SOURCE(REPO | RDDDS)** command to create resource and descriptor definitions or replace existing resource and descriptor definitions in an online IMS system by using the definitions in a resource definition data set (RDDDS) or the IMSRSC repository.

The **IMPORT** command can be issued through TSO SPOC, IBM Management Console for IMS and DB2 for z/OS, the Manage Resources options in the IMS Applications menu, or any user-written programs that issue commands through OM API. These commands can also be issued to an IMSplex by using the Batch SPOC utility.

Subsections:

- [“Environment” on page 803](#)
- [“Syntax” on page 804](#)
- [“Keywords” on page 805](#)
- [“Usage notes” on page 809](#)
- [“Output fields” on page 811](#)
- [“Return and reason codes” on page 812](#)
- [“Completion codes” on page 815](#)
- [“Examples” on page 826](#)

### Environment

The following table lists the environments (DB/DC, DBCTL, and DCCTL) in which you can use the command and keywords.

*Table 337. Valid environments for the IMPORT command and keywords*

| Command / Keywords | DB/DC | DBCTL | DCCTL |
|--------------------|-------|-------|-------|
| <b>IMPORT</b>      | X     | X     | X     |
| DEFN               | X     | X     | X     |
| NAME               | X     | X     | X     |
| OPTION             | X     | X     | X     |
| RDDSDSN            | X     | X     | X     |

Table 337. Valid environments for the IMPORT command and keywords (continued)

| Command / Keywords         | DB/DC | DBCTL | DCCTL |
|----------------------------|-------|-------|-------|
| SCOPE                      | X     | X     | X     |
| SOURCE(RDDS), SOURCE(REPO) | X     | X     | X     |
| TYPE                       | X     | X     | X     |

## Syntax

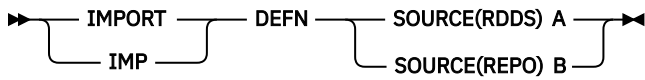

A

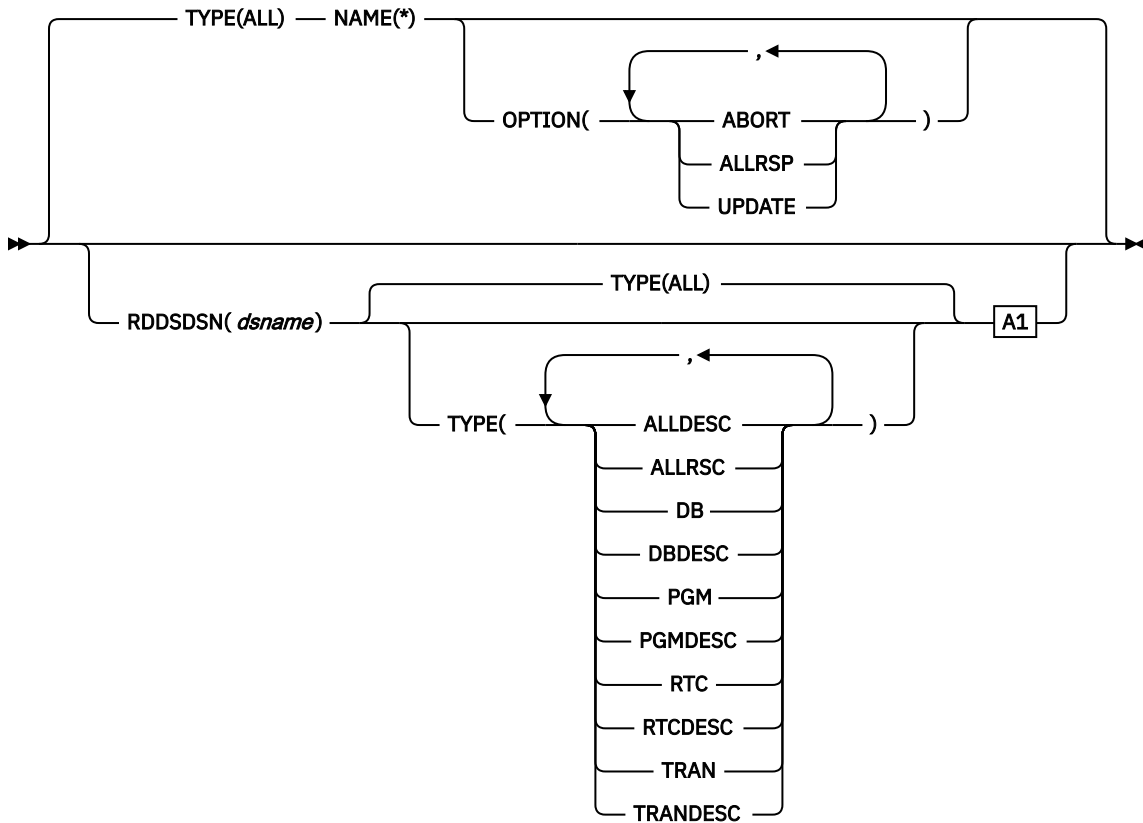

A1



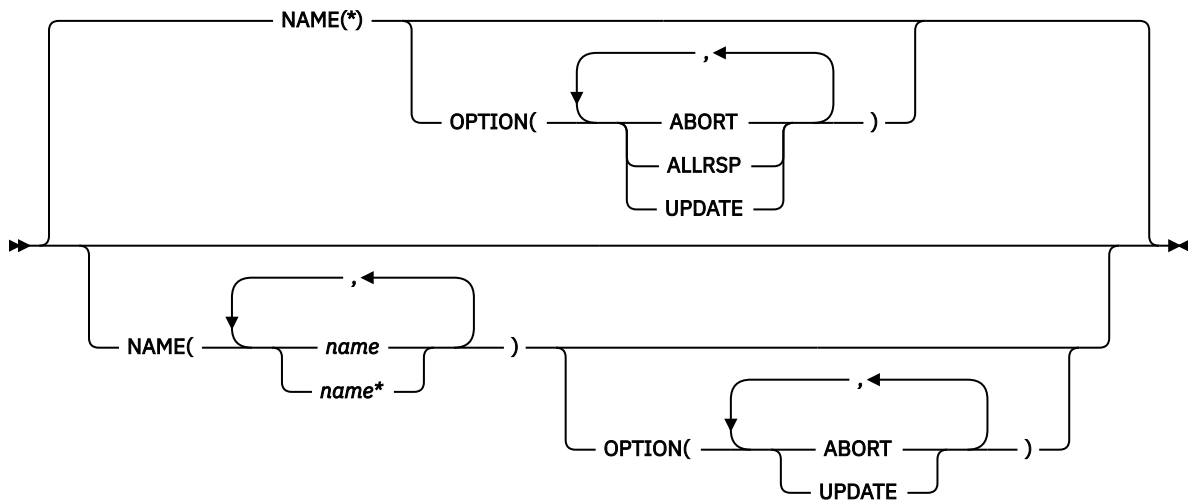

## B

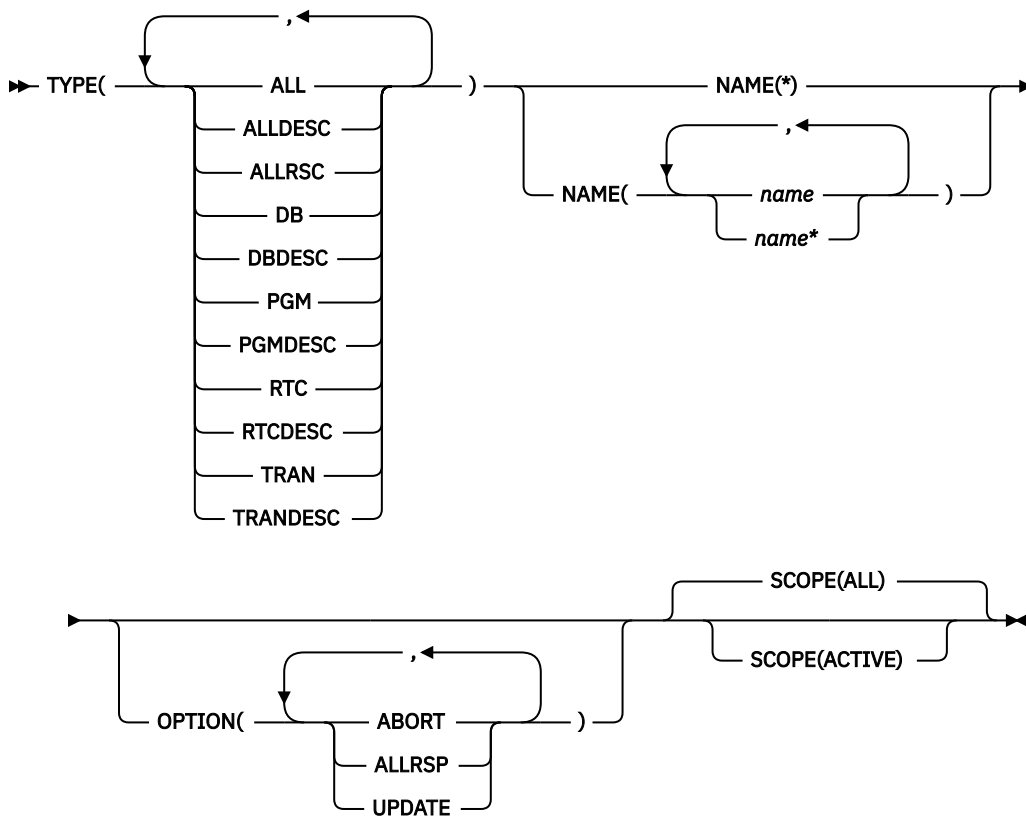

## Keywords

The following keywords are valid for the **IMPORT** command:

### DEFN

A required keyword.

### NAME()

Specifies the 1-8 character name of a resource or descriptor for which you are importing a definition from either an RDDS or the repository. Wildcards can be specified in the name. The name is a repeatable parameter. If the **NAME** parameter specified is a specific name or a wildcard, command responses are returned for all the resource names that are processed. **NAME** is an optional parameter,

and if not specified, it defaults to NAME(\*). For NAME(\*), command responses are returned only for the resource and descriptor names that resulted in an error. OPTION(ALLRSP) can be specified with NAME(\*) to obtain the command responses for all of the resource and descriptor names that are processed.

### **OPTION()**

Specifies additional functions to be performed along with the command.

You can specify the following options:

#### **ABORT**

Processes the definitions specified as a group. If an error occurs while processing any of the resource or descriptor definitions, the **IMPORT** command fails and none of the resource or descriptor definitions are imported.

If option ABORT is not specified and an error occurs while processing a particular resource or resource descriptor, that resource or descriptor is not imported. Import processing continues with the next resource or descriptor definition.

**Important:** Commands such as **CREATE**, **DELETE**, **EXPORT**, **IMPORT**, and **UPDATE**, which affect the definitional attributes of resources and descriptors, are not allowed while the **IMPORT OPTION(ABORT)** command is in progress.

#### **ALLRSP**

Indicates that a response is to be returned for all resources and descriptors that are processed by this command. If NAME(\*) is specified, the default action is to return a response only for the resources and descriptors that result in an error.

OPTION(ALLRSP) can be used with NAME(\*) to request a response for all resources and descriptors processed by this command. If a name value other than NAME(\*) is specified, the default action is to return a response for all resources and descriptors processed by the command. If OPTION(ALLRSP) is specified with a name value other than NAME(\*) the ALLRSP parameter is ignored.

#### **UPDATE**

Indicates that if the definition being imported is for a resource or descriptor that already exists in IMS, the imported definition should be used to replace the existing runtime resource or descriptor definition. If the definition being imported is for a resource or descriptor that does not exist, the imported definition should be used to create the runtime resource or descriptor definition. If the UPDATE option is not specified and a runtime definition already exists for the resource or descriptor, the import of the resource or descriptor definition fails.

In most cases, the affected resource must not be in use when the **IMPORT OPTION(UPDATE)** command is entered. If the resource is in use, the import of the stored definition fails. The following transaction attributes can be updated if the transaction is in use: CLASS, LCT, LPRI, NPRI, MAXRGN, PARLIM, PLCT, PLCTTIME, SEGNO, SEGSZ, and TRANSTAT. The following program attribute can be updated while the program is in use: TRANSTAT.

To minimize the likelihood that the import of a resource definition will fail, do the following steps before issuing the **IMPORT** command:

1. Stop the resource.
2. Query the resource to check for work in progress.
3. Complete the work, if any.

If the imported definition is for a resource or descriptor that already exists in IMS, the import time stamp in the existing runtime definition is replaced with the time the **IMPORT** command was received by OM. If one or more of the attributes in the existing runtime definition are different from the attributes in the imported definition, the update time stamp is also updated with the time the **IMPORT** command was received by OM. The access and create time stamps in the existing runtime definition are unchanged.

If the imported definition is for a resource or descriptor that does not exist in IMS, the import time stamp in the newly created runtime definition is set to the time the **IMPORT** command was

received by OM. The create time stamp is obtained from the imported definition and stored in the new runtime definition.

If the imported definition is for a descriptor that has DEFAULT(N) defined and the runtime descriptor is the current default descriptor, the default value is not updated. The runtime descriptor remains the default descriptor. Other attributes are updated, but the default value remains unchanged. To change the default descriptor so that it is no longer the default descriptor, you must update another descriptor to be the default descriptor. If the imported definition has DEFAULT(Y) defined, the updated runtime descriptor becomes the current default descriptor.

The DEFNTYPE of a newly created definition is set to IMPORT. The DEFNTYPE is set to IMPORT when an existing definition is replaced with a new definition.

When the ABORT option is also specified, the definitions are imported as a group. If an error occurs while processing any of the resource or descriptor definitions, the **IMPORT** command fails and none of the resource or descriptor definitions are imported.

If the ABORT option is not specified and an error occurs while processing a resource or descriptor definition, the resource or descriptor is not imported. Import processing continues with the next resource or descriptor definition. In an IMSplex environment, the **IMPORT** command might succeed on some IMS systems and fail on others.

### **RDDSDSN(dsname)**

Specifies an optional RDDS from which resource and descriptor definitions are to be imported. The data set specified can be either a system RDDS or a non-system RDDS. If the RDDSDSN keyword is not specified, resource and descriptor definitions are imported from the most current system RDDS. If RDDS system data sets are not defined in the DFSDFxxx PROCLIB member, the RDDSDSN keyword is required on the **IMPORT** command.

### **SCOPE**

Indicates the scope of the **IMPORT DEFN SOURCE(REPO)** command and whether any action is to be taken in Resource Manager (RM), along with the IMS systems that receive the command. The IMS systems that receive the command are identified by the ROUTE keyword on the OM API (such as TSO SPOC or Batch SPOC).

**Recommendation:** Specify ROUTE(ALL) so that all active IMS systems that have the resources defined will receive the command. If a ROUTE list is specified, the command is processed only by the IMS systems that are on the list. Other active IMS systems that have the resources defined but not on the ROUTE list will not be synchronized with the repository because they do not receive the command.

### **ALL**

Indicates that the runtime resource definitions of the resource and descriptor names specified on the **IMPORT** command apply to all the IMS systems to which the resources and descriptors are defined in the repository.

When an **IMPORT DEFN SOURCE(REPO) SCOPE(ALL)** command is issued, resource definitions for the specified resource and descriptor names are read from the IMSRSC repository and imported at all active systems that receive the **IMPORT** command.

If SCOPE(ALL) is specified and an IMS system to which the resources and descriptors are defined is not active, the command master IMS calls RM to create or update an IMS change list in the repository with a list of the resource and descriptor names being imported. The resource definitions of all the resource names in the IMS change list are imported at warm or emergency restart so that the IMS is synchronized with all other IMS systems in the IMSplex. If a change list is created in the repository, a response line is returned on the **IMPORT** command for each resource name in the change list with the IMSID of the IMS for which the change list is created, along with the import type (IMPTYPE) of the change list.

If the **IMPORT DEFN SCOPE(ALL)** command is issued without the OPTION(UPDATE) keyword and routed to an IMS system that has one or more resources or descriptors already defined, the **IMPORT** command results in a nonzero return code. The import might be successful at other active

IMS systems, and the command might be successful in creating the change list in the IMSRSC repository for inactive IMS systems.

To avoid a nonzero return code and reason code from the **IMPORT DEFN SCOPE(ALL)** command, do one of the following:

- Specify the **IMPORT DEFN SCOPE(ALL)** command with the **OPTION(UPDATE)** keyword and route it to all IMS systems (**ROUTE(\*)**)
- Route the **IMPORT DEFN SCOPE(ALL)** command to active IMS systems in which the resource or descriptors do not exist

### **ACTIVE**

Indicates that the runtime resource definitions of the resource and descriptor names specified on the **IMPORT** command apply only to the active IMS systems to which the resources and descriptors are defined in the repository.

If an IMS system to which the resources and descriptors are defined is not active, that IMS does not obtain the resource definitions during warm or emergency restart because change lists are not created with the **SCOPE(ACTIVE)** keyword. To synchronize runtime resource definitions in all IMS systems in the IMSplex, you must issue the **IMPORT** command manually.

### **SOURCE()**

Specifies the source of the resource and descriptor definitions to be imported.

### **RDDS**

Specifies that resource and descriptor definitions are to be imported from an RDDS. If a data set name is not specified on the command with the **RDDSDSN()** keyword, the most current system RDDS is used.

Even if IMS is enabled with the repository, import from system RDDSs is allowed if the system RDDSs are defined. Import from a non-system RDDS is also valid when IMS is enabled to use the repository.

### **REPO**

Indicates that the runtime resource definitions of the resource names specified on the **NAME** keyword are to be imported from the stored resource definitions in the repository. **SOURCE(REPO)** is valid only when IMS is enabled to use the repository.

The **IMPORT** command does not import resource and descriptor definitions from the repository if the resource or descriptor names do not exist in the IMS resource list for the IMS in the repository. You must first add the resource and descriptor names to the IMS resource list for the IMS before issuing the **IMPORT** command at the IMS. An **EXPORT** command with the **SET(IMSID())** option can be used to add the resource definitions to an IMS resource list in the repository.

The resource definitions are imported from the repository and created in IMS if the resource definitions do not exist on the local IMS. If the resource definitions exist at the local IMS and **OPTION(UPDATE)** is specified, the resource definitions are replaced in the local IMS system.

### **TYPE()**

Specifies the type of resource or descriptor definition to import.

**TYPE()** is not supported when **SOURCE(CATALOG)** is specified.

You can specify the following resource types:

### **ALL**

**ALL** specifies that all types of resource and descriptor definitions (**DB**, **DBDESC**, **PGM**, **PGMDESC**, **RTC**, **RTCDESC**, **TRAN**, and **TRANDESC**) are to be imported. **ALL** is the only valid value when importing from a system RDDS.

### **ALLDESC**

**ALLDESC** specifies that all definitions for all descriptor types (**DBDESC**, **PGMDESC**, **RTCDESC**, and **TRANDESC**) are to be imported. **TYPE(ALLDESC)** is not valid when importing from a system RDDS.

**ALLRSC**

ALLRSC specifies that all definitions for all resource types (DB, PGM, RTC, and TRAN) are to be imported. TYPE(ALLRSC) is not valid when importing from a system RDDS.

**DB**

DB specifies that one or more database definitions are to be imported. TYPE(DB) is not valid when importing from a system RDDS.

**DBDESC**

DBDESC specifies that one or more database descriptor definitions are to be imported. TYPE(DBDESC) is not valid when importing from a system RDDS.

**PGM**

PGM specifies that one or more program definitions are to be imported. TYPE(PGM) is not valid when importing from a system RDDS.

**PGMDESC**

PGMDESC specifies that one or more program descriptor definitions are to be imported. TYPE(PGMDESC) is not valid when importing from a system RDDS.

**RTC**

RTC specifies that one or more route code definitions are to be imported. TYPE(RTC) is not valid when importing from a system RDDS.

**RTCDESC**

RTCDESC specifies that one or more route code descriptor definitions are to be imported. TYPE(RTCDESC) is not valid when importing from a system RDDS.

**TRAN**

TRAN specifies that one or more transaction definitions are to be imported. TYPE(TRAN) is not valid when importing from a system RDDS.

**TRANDESC**

TRANDESC specifies that one or transaction descriptor definitions are to be imported. TYPE(TRANDESC) is not valid when importing from a system RDDS.

## Usage notes

The **IMPORT DEFN SOURCE(REPO | RDDS)** command can be issued only through the Operations Manager (OM) API. This command applies to DB/DC, DBCTL and DCCTL systems.

The **IMPORT DEFN SOURCE(REPO | RDDS)** command is not valid on the XRF alternate or FDBR region.

The **IMPORT DEFN SOURCE(REPO | RDDS)** command is valid for the following resource types:

- MODBLKS resources, such as the runtime resource attributes for databases, application programs, transactions, or Fast Path routing codes, if dynamic resource definition (DRD) is enabled by MODBLKS=DYN in either the COMMON\_SERVICE\_LAYER section of the DFSDFxxx or DFSCGxxx PROCLIB member)

The **IMPORT DEFN SOURCE(REPO | RDDS)** command is defined as ROUTE=ALL to OM. When the **IMPORT** command is issued, OM routes the **IMPORT** command to all active IMS systems (or to all IMS systems specified in the route list if the ROUTE parameter is specified on the CSLOMCMD or CSLOMI request) that have registered interest in the command. All IMS systems that receive the command attempt to process the **IMPORT** command and import the resource definitions from the specified source. If you want the **IMPORT** command to be processed by a specific IMS, the ROUTE parameter must be used to direct the **IMPORT** command to the specific IMS.

If the definition is for a resource or descriptor that is unknown to IMS, the IMS creates the internal control blocks that are needed to manage the resource. If the definition is for a resource or descriptor that exists in IMS and OPTION(UPDATE) is not specified, the definition is not imported. If the definition is for a resource or descriptor that exists in IMS and OPTION(UPDATE) is specified, the definition is imported and the existing runtime resource or descriptor definition is replaced with the attributes from the imported definition.

If the SOURCE(RDDS) keyword is specified for the **IMPORT** command, resource and descriptor definitions are created from or replaced by definitions from the system RDDS with the most current resource and descriptor definitions, or they are imported from an RDDS specified with the RDDS(SN) keyword on the **IMPORT** command. The RDDS specified with the RDDS(SN) keyword can be a system RDDS or a non-system RDDS. A system RDDS is one of the RDDSs defined with the RDDS(SN)= parameter in the DYNAMIC\_RESOURCES section of the DFSDFxxx PROCLIB member. A system RDDS contains all of the resource and descriptor definitions for a single IMS. If using automatic import or automatic export, each IMS must have its own set of system RDDSs.

If an RDDS contains multiple definition instances for the same resource or descriptor, the last definition instance imported is the definition used to create the resource or descriptor.

The definitions for IMS-defined resources, such as the Fast Path utility (DBF#FPU0) and the IMS-defined descriptors (DBFDSRT1, DFSDSDB1, DFSDSPG1 and DFSDSTR1), cannot be exported or imported. IMS-defined resources and descriptors are created at IMS restart. If the name of an IMS-defined resource or descriptor is specified in the NAME() parameter, the import of the resource or descriptor definition fails with a completion code of 48 and a completion code text of "NOT ALLOWED FOR IMS RESOURCE".

**Rules and restrictions that apply to the IMPORT command:** The **IMPORT DEFN SOURCE(REPO | RDDS)** command imports resource and descriptor definitions from an RDDS or the repository and uses the definitions to create the runtime resource and descriptor definitions in the online IMS system. Therefore, the same rules and restrictions that apply to the **CREATE** commands for databases, programs, routing codes, and transactions also apply to the **IMPORT** command. For example, when importing a transaction definition, the definition for the program referenced by the transaction must either be imported at the same time, or the program must already be defined in the online IMS. The definitional attributes of the transaction must correspond to the definitional attributes of the program. The only exception is the **CREATE DB** command for a HALDB master database. The **CREATE DB** command for a HALDB master database creates the runtime resource definitions for both the HALDB master database and its associated HALDB partition databases. The **IMPORT** command for a HALDB master database creates the runtime resource definition for the HALDB master database only. The runtime resource definitions for the HALDB partition databases must be created with either a **/START DB** or **UPDATE DB START (ACCESS)** command for the HALDB master database.

The runtime resource and descriptor definitions that are created by the **IMPORT** command exist in the online system until IMS terminates, unless they are deleted using a **DELETE** command. They are recoverable across an IMS warm start or emergency restart. To preserve the resource and descriptor definitions across a cold start, export the definitions to an RDDS or the repository before IMS terminates, and then import the stored definitions from the RDDS or the repository back into IMS either during cold start processing by using the automatic import function or, once IMS is up and running, by using the **IMPORT** command.

Runtime resource and descriptor definitions are lost if IMS is cold started (**/NRE CHKPT 0** or **/ERE COLDSYS**), unless an automatic import from the current system RDDS or the repository is done during cold start.

When a transaction resource definition is imported from either an RDDS or the repository and a new runtime definition is created, the current priority (CPRI) is initialized to the normal priority (NPRI). When a transaction resource definition is imported from either an RDDS or the repository and an existing runtime definition is updated, the CPRI value is not updated.

When OPTION(ABORT) is not specified, **IMPORT**, **EXPORT**, and automatic export are processed serially. **CREATE**, **DELETE**, and **UPDATE** commands, which do not affect the imported resources, can run in parallel with the **IMPORT** command.

### **HALDB considerations**

The **IMPORT** command creates runtime resource and descriptor definitions in an online IMS system from definitions that have been exported to an RDDS or the repository. Whereas HALDB master database definitions can be exported to an RDDS or the repository, HALDB partition definitions cannot be exported to an RDDS or the repository. If the definition for a HALDB master database is imported, the **IMPORT** command creates only runtime resource definitions for the HALDB master database; it does not create runtime resource definitions for the associated HALDB partitions. A completion code of "D" is returned for

the HALDB master database and the completion code text of "RSC NEEDS STA DB ON HALDB MASTER" is returned.

After a HALDB master database is imported, you must issue a **/START DB** or **UPDATE DB** command on the HALDB master database to build its associated partition structures.

- **/START DB HALDB\_master**
- **UPDATE DB NAME(HALDB\_master) START(ACCESS)**

### **MSDB considerations**

Like a **CREATE DB** command for an MSDB database, an **IMPORT** command for an MSDB database creates runtime resource definitions for the MSDB. If a **CREATE DB** or **IMPORT** command creates one or more MSDB databases, the MSDB resource control blocks are logged in the checkpoint log records. However, the MSDB databases cannot be used and they are not written to the MSDB checkpoint data sets (MSDBCPx) until they are loaded into online storage either at the next IMS cold start, or IMS warm start with MSDBLOAD (**/NRESTART MSDBLOAD**) from the MSDBINIT data set.

Like the **UPDATE DB** command, an **IMPORT** command that changes runtime resource definition attributes such as the RESIDENT attribute is rejected for MSDBs and DEDBs. An **IMPORT** command that changes the access type of an MSDB is also rejected.

If IMS is warm-started without MSDBLOAD (**/NRESTART**) or is emergency restarted (**/ERESTART**) without loading MSDB databases from the MSDBINIT data set, a new message, DFS2608W MSDBS NOT AVAILABLE - NO MSDBCPX DATA SET NAMES FOUND IN CHECKPOINT, is issued at IMS warm or emergency restart. IMS continues to run with no MSDB databases available until MSDB databases are loaded from the MSDBINIT data set during a subsequent cold start or warm restart with MSDBLOAD (**/NRESTART MSDBLOAD**).

## **Output fields**

When SOURCE(RDDS) is specified, message DFS3405I is returned by each IMS that processes the **IMPORT** command. It indicates whether all, some, or none of the specified resource or descriptor definitions were imported. It also contains the name of the data set from which the resource or descriptor definitions were imported. Each DFS3405I message is encapsulated in a single set of <msg> </msg> XML tags.

When SOURCE(REPO) is specified, the **IMPORT** command results in message DFS3406I, which indicates that the import from the repository was successful, or DFS3407E, which indicates that the import was not successful. These messages include the repository name and repository type. If the import from the repository is not successful because of a CSLRPQRY error, the DFS3407E message consists of the CSLRPQRY request return code and reason code. The CSLRPQRY return and reason codes are described in the CSLRRR macro.

In addition to the message, command response output is also returned in XML tag structure. The following table shows the **IMPORT** response output fields. The columns in the table are as follows:

### **Short label**

Contains the short label generated in the XML output.

### **Long label**

Contains the long label generated in the XML output.

### **Keyword**

Identifies keyword on the command that caused the field to be generated. N/A (not applicable) appears for output fields that are always returned. The value *error* appears for output fields that are returned only in the case of an error.

### **Meaning**

Provides a brief description of the output field.

Table 338. Output fields for the IMPORT command

| Short label | Long label | Keyword      | Meaning   |
|-------------|------------|--------------|---|
| CC          | CC         | N/A          | Completion code.  |
| CCTXT       | CCText     | <i>error</i> | Completion code text that briefly explains the meaning of the nonzero completion code.  |
| IMPTYPE     | ImpType    | N/A          | <p>Import type of the resource or descriptor. One of the following values might be set:</p> <p><b>CREATE</b><br/>Indicates that a resource or descriptor definition is imported and a new resource or descriptor is created.</p> <p><b>UPDATE</b><br/>Indicates that the attributes of an existing runtime resource or descriptor definition are updated by the import.</p> <p><b>CHGLIST</b><br/>Indicates that the command master IMS is creating or updating the IMS change list for one or more IMS systems that are down.<br/><br/>Indicates that the command master IMS created or updated the IMS change list for the IMS whose IMSID is in the IMSid column. The change list has been created or updated because the IMS is down and the <b>IMPORT DEFN SCOPE(ALL)</b> command is specified.</p> <p><b>(blank)</b><br/>Indicates that a resource or descriptor definition is not imported due to an error, or that none of the attributes of an existing resource or descriptor definition are changed by the import.</p> |
| IMSID       | IMSid      | SCOPE(ALL)   | IMSID of the IMS that is down and whose change list is updated with this resource. If the change list does not exist, it is created.  |
| MBR         | MbrName    | N/A          | IMSplex member that built the output line.  |
| NAME        | Name       | NAME         | Descriptor or resource name.  |
| OLDDEF      | OldDefault | N/A          | Old default descriptor name if this descriptor was made the default by the IMPORT command. The old default descriptor is no longer the default.   |
| TYPE        | Type       | TYPE         | Type of resource or descriptor, which can be DB, DBDESC, PGM, PGMDESC, RTC, RTCDESC, TRAN, or TRANDESC.   |

## Return and reason codes

The following table includes the return and reason codes and a brief explanation of the codes. The return or reason code returned for the command might also indicate an error from a CSL request.



Table 339. Return and reason codes for the **IMPORT** command

| Return code | Reason code | Meaning   |
|-------------|-------------|---|
| X'00000000' | X'00000000' | Command completed successfully. If NAME(*) is not specified (or defaulted to), the command output contains a line for each resource, accompanied by its completion code. If NAME(*) is specified and OPTION(ALLRSP) is not specified, no output lines are returned. If NAME(*) is specified and OPTION(ALLRSP) is specified, output lines are returned for each resource or descriptor definition imported. |
| X'00000008' | X'00002004' | Invalid command keyword or invalid command keyword combination.   |
| X'00000008' | X'00002008' | Insufficient number of keywords.  |
| X'00000008' | X'00002028' | The command contains an invalid keyword.  |
| X'00000008' | X'0000211F' | Unable to determine the import data set name. The RDDSDSN() keyword was not specified on the command, and there are no system RDDs defined.   |
| X'00000008' | X'00002138' | Values other than NAME(*) and TYPE(ALL) were specified, and either the RDDSDSN() keyword was not specified or the data set specified with the RDDSDSN() keyword is a system RDDs.   |
| X'00000008' | X'00002139' | A value was specified for the RDDSDSN keyword, but SOURCE(RDD) was not specified.   |
| X'00000008' | X'0000214E' | SOURCE(RDD) and the SCOPE() keyword conflict.   |
| X'00000008' | X'00002176' | The Command (CMD) master was not provided.  |
| X'00000008' | X'00002177' | The Command (CMD) master was provided.  |
| X'0000000C' | X'00003000' | Command was successful for some resource definitions but failed for others. If OPTION(ALLRSP) is specified, the command output contains a line for each resource, accompanied by its completion code. If OPTION(ALLRSP) is not specified, output lines are only returned for resources with nonzero completion codes.   |
| X'0000000C' | X'00003008' | Command was not successful for any of the resource definitions. The command output contains a line for each resource, accompanied by its completion code.   |
| X'00000010' | X'00004004' | No CQS address space.   |
| X'00000010' | X'00004100' | Resource structure is full.   |
| X'00000010' | X'00004104' | No RM address space.  |
| X'00000010' | X'00004108' | No SCI address space.   |
| X'00000010' | X'0000400C' | Command is not valid on the XRF alternate.  |
| X'00000010' | X'00004018' | No resource structure exists, or resource structure is not available.   |
| X'00000010' | X'0000401C' | Command is not valid on the FDBR region.  |
| X'00000010' | X'00004038' | No requests were processed. OPTION(ABORT) was specified on the <b>IMPORT</b> command, and the number of database definitions to be imported exceeds 32K.  |

Table 339. Return and reason codes for the **IMPORT** command (continued)

| Return code | Reason code | Meaning  |
|-------------|-------------|--|
| X'00000010' | X'00004114' | Unable to access the RDDS. The RDDS is either the system RDDS with the most current data or the data set specified with the RDDSDSN() keyword.   |
| X'00000010' | X'00004118' | Unable to allocate the RDDS. The RDDS is either the system RDDS with the most current data or the data set specified with the RDDSDSN() keyword.   |
| X'00000010' | X'0000411C' | The RDDS from which the definitions are to be imported contains invalid data.  |
| X'00000010' | X'00004120' | Online change phase is in progress.  |
| X'00000010' | X'00004124' | The <b>IMPORT</b> command is rejected, because a process of a similar type is in progress. Possible commands in progress are <b>/DISPLAY MODIFY, CREATE DB, or DELETE DB</b> commands. Wait until the other process completes and issue the <b>IMPORT</b> command again. |
| X'00000010' | X'00004300' | Command is not allowed, because online change for MODBLKS is enabled (DFSDFxxx or DFSCGxxx defined with MODBLKS=OLC, or MODBLKS not defined).  |
| X'00000010' | X'00004500' | IMS is not enabled with the repository.  |
| X'00000010' | X'00004502' | Repository not available   |
| X'00000010' | X'00004504' | Repository spare recovery is in progress.  |
| X'00000010' | X'00004505' | No IMS resource list exists, or no resources for the resource type exist in the IMS resource list.   |
| X'00000010' | X'00004507' | Repository access was denied.  |
| X'00000010' | X'00004508' | Repository maximum put length exceeded.  |
| X'00000010' | X'00004509' | RM data version is lower than the IMS data version.  |
| X'00000010' | X'0000450A' | Repository Server (RS) is being shut down.   |
| X'00000010' | X'0000450B' | RS is not available.   |
| X'00000010' | X'0000450C' | RS is busy.  |
| X'00000010' | X'0000450D' | RM failed to define some of the internal fields related to the IMSRSC repository.  |
| X'00000014' | X'00005000' | The <b>IMPORT</b> command was terminated, because <b>IMODULE GETSTOR</b> storage could not be obtained.  |
| X'00000014' | X'00005004' | DFSOCMD response buffer could not be obtained.   |
| X'00000014' | X'00005008' | DFSPPOOL storage could not be obtained.  |
| X'00000014' | X'0000500C' | AWE could not be obtained.   |
| X'00000014' | X'00005010' | Unable to obtain latch.  |
| X'00000014' | X'00005018' | Unable to obtain a 64-bit buffer.  |
| X'00000014' | X'00005100' | RM request error.  |
| X'00000014' | X'00005104' | Unexpected CQS error.  |

Table 339. Return and reason codes for the **IMPORT** command (continued)

| Return code | Reason code | Meaning  |
|-------------|-------------|--|
| X'00000014' | X'00005108' | SCI request error.   |
| X'00000014' | X'00005110' | Repository error.  |
| X'00000014' | X'00005115' | Import from the IMSRSC repository change list is in progress. Reissue the command after the change list processing is complete.  |
| X'00000014' | X'0000551C' | A request to read data from the repository was rejected because a corrupted resource list was detected. The <b>IMPORT DEFN</b> command is rejected because the resource list is not usable. Contact IBM Software Support. Send in the output from the command in error, a dump of the local RM address space where the command executed or the dump of all RM address spaces in the IMSplex. Also, send a copy of the IMSRSC repository RID and RMD data sets. |
| X'00000014' | X'00005FFF' | The <b>IMPORT</b> command could not be processed because of an internal error.   |
| X'02000008' | X'0000203C' | The command contains an invalid keyword parameter value.   |
| X'02000008' | X'00003004' | No requests were successful.   |

## Completion codes

Errors unique to the processing of this command are returned as completion codes. The following table includes an explanation of the completion codes.

Table 340. Completion codes for the **IMPORT** command

| Completion code | Completion code text             | Meaning  |
|-----------------|----------------------------------|--|
| 0               |                                  | Command completed successfully for resource or descriptor definition.  |
| 6               | RESOURCE NEEDS ONLINE CHANGE     | The database definition was imported, but an online change is needed if the database is to be used.  |
| 9               | NO IMPORT - OPTION ABORT         | The resource or descriptor definition was not imported. An error occurred importing one or more resource or descriptor definitions and <b>OPTION(ABORT)</b> was specified.                             |
| A               | NO IMPORT - SAME RSC FOUND LATER | There were multiple definitions for the same resource or descriptor on the RDDS. The last instance of the resource or descriptor definition on the RDDS was used to create the resource or descriptor. |
| D               | RSC NEEDS STA DB ON HALDB MASTER | The HALDB master database definition was imported. In order to create the database partitions, a <b>/STA DB</b> or <b>UPD DB START (ACCESS)</b> command on the master HALDB is required.               |

Table 340. Completion codes for the **IMPORT** command (continued)

| Completion code | Completion code text           | Meaning   |
|-----------------|--------------------------------|---|
| E               | IMPORT CANNOT SET DEFLT DESC   | The descriptor definition was imported, but the descriptor could not be made the default descriptor as defined.   |
| F               | GLOBAL STATUS NOT APPLIED      | The resource definition was imported, but global status could not be applied to the resource.   |
| 10              | NO RESOURCES FOUND             | Resource or descriptor name is invalid, or the wildcard parameter specified does not match any resource names.  |
| 11              | RESOURCE ALREADY EXISTS        | The resource or descriptor being imported already exists. No import was done.   |
| 16              | INVALID CLASS VALUE            | The transaction class value is invalid. The transaction definition was not imported. This should not occur if the definition was created by a valid export or by an IBM-supplied utility.   |
| 17              | ANOTHER CMD IN PROGRESS        | Another command (such as <b>DELETE PGM</b> or <b>UPDATE PGM</b> ) is in progress for the program referenced by the transaction or routing code definition being imported.   |
| 19              | CMTMODE=MULT/WFI=Y CONFLICT    | Wait-for-input WFI(Y) option conflicts with commit mode CMTMODE(MULT). The transaction definition was not imported. This should not occur if the definition was created by a valid export or by an IBM-supplied utility.                        |
| 1A              | IN CONVERSATION                | Transaction is in conversation. The conversation ID and the terminal in conversation are returned separately. The terminal can be a static node, node and user, dynamic user, APPC luname, or OTMA tmember and tpipe.                           |
| 1B              | CONV=Y/CMTMODE=MULT CONFLICT   | Conversation option CONV(Y) conflicts with commit mode CMTMODE(MULT). The transaction definition was not imported. This should not occur if the definition was created by a valid export or by an IBM-supplied utility.                         |
| 1D              | XRF TAKEOVER IS IN PROGRESS    | The <b>IMPORT DEFN SOURCE(CATALOG)</b> command cannot be processed, because a takeover is in progress.  |
| 1E              | CONV=N/SPASZ/SPATRUNC CONFLICT | Non-conversation CONV(N) option conflicts with conversation attributes SPASZ > 0 or SPATRUNC. The transaction definition was not imported. This should not occur if the definition was created by a valid export or by an IBM-supplied utility. |
| 1F              | CONV=Y/RECOVER=N CONFLICT      | Conversation CONV(Y) option conflicts with recovery RECOVER(N) option. The transaction definition was not imported. This should not occur if the definition was created by a valid export or by an IBM-supplied utility.                        |

Table 340. Completion codes for the **IMPORT** command (continued)

| Completion code | Completion code text               | Meaning  |
|-----------------|------------------------------------|--|
| 1F2             | DIRECTORY BLDL FAILED              | During processing of the <b>IMPORT DEFN SOURCE (CATALOG)</b> command, IMS encountered a BLDL error while reading the directory data sets.  |
| 21              | CONV=Y REQUIRES SPASZ/<br>SPATRUNC | Conversation CONV(Y) option requires conversation attributes SPASZ and SPATRUNC. The transaction definition was not imported. This should not occur if the definition was created by a valid export or by a utility supplied by IBM. |
| 22              | CPIC TRAN ALREADY EXISTS           | CPI-C transaction already exists by the same name. The transaction definition was not imported.  |
| 23E             | STAGING BLDL FAILED                | During processing of the <b>IMPORT DEFN SOURCE (CATALOG)</b> command, IMS encountered a BLDL error while reading the staging data sets.  |
| 29              | DOPT=Y/RESIDENT=Y<br>CONFLICT      | Dynamic DOPT(Y) option conflicts with resident RESIDENT(Y) option. The program definition was not imported. This should not occur if the definition was created by a valid export or by an IBM-supplied utility.                     |
| 2A              | DOPT=Y/PARALLEL CONFLICT           | Dynamic DOPT(Y) option conflicts with parallel schedule SCHDTYPE(PARALLEL) option. The program definition was not imported. This should not occur if the definition was created by a valid export or by an IBM-supplied utility.     |
| 2B              | INVALID EDITRTN NAME               | EDITRTN name is invalid. The transaction definition was not imported. This should not occur if the definition was created by a valid export or by an IBM-supplied utility.   |
| 2C              | MAX 255 EDIT ROUTINES<br>EXCEEDED  | Transaction definition to be imported specifies a new edit routine name, which exceeds the limit of 255 edit routines. The transaction definition was not imported.  |
| 2D              | INVALID EMHBSZ VALUE               | EMH buffer size EMHBSZ value is invalid. The transaction definition was not imported. This should not occur if the definition was created by a valid export or by an IBM-supplied utility.   |
| 2F              | FP=E/BMPTYPE=Y CONFLICT            | Fast Path exclusive FP(E) option conflicts with BMP type BMPTYPE(Y). The program definition was not imported. This should not occur if the definition was created by a valid export or by an IBM-supplied utility.                   |
| 31              | NOT ALLOWED FOR A DEDB             | The resident attribute in the imported database definition differs from the resident attribute in the runtime resource definition. The resident option of a DEDB cannot be changed.  |

Table 340. Completion codes for the **IMPORT** command (continued)

| Completion code | Completion code text           | Meaning   |
|-----------------|--------------------------------|---|
| 32              | NOT ALLOWED FOR AN MSDB        | The resident attribute in the imported database definition differs from the resident attribute in the runtime resource definition. The resident option of an MSDB cannot be changed.  |
| 35              | FP=E/EDITRTN CONFLICT          | Fast Path exclusive FP(E) option conflicts with edit routine EDITRTN. The transaction definition was not imported. This should not occur if the definition was created by a valid export or by an IBM-supplied utility.   |
| 36              | FP=E/FP=N PGM CONFLICT         | Fast Path exclusive FP(E) option conflicts with program defined as non-Fast Path FP(N). The transaction definition was not imported.  |
| 37              | FP=E/LANG=JAVA CONFLICT        | Fast Path exclusive FP(E) option conflicts with Java language LANG(JAVA) option. The program definition was not imported. This should not occur if the definition was created by a valid export or by an IBM-supplied utility.  |
| 39              | FP=E TRAN FOR RTC EXISTS       | The routing code was created by IMS for a Fast Path exclusive transaction and cannot be updated with an <b>IMPORT</b> command. The attributes of the routing code can be updated with an <b>UPDATE TRAN</b> command or an <b>IMPORT</b> command that updates the Fast Path exclusive transaction.                                   |
| 3A              | FP=E OR P/MSK KEYWORD CONFLICT | Fast Path exclusive FP(E) or Fast Path potential FP(P) conflicts with MSK MSNAME or SIDR/SIDL value. The transaction definition was not imported. This should not occur if the definition was created by a valid export or by an IBM-supplied utility.  |
| 3B              | FP/MSGTYPE=MULTSEG CONFLICT    | Fast Path exclusive FP(E) or Fast Path potential FP(P) conflicts with multiple segment MSGTYPE(MULTSEG) option. The transaction definition was not imported. This should not occur if the definition was created by a valid export or by an IBM-supplied utility.   |
| 3C              | MAXRGN/PARLIM=65535 CONFLICT   | The maximum region count MAXRGN value conflicts with the parallel limit count PARLIM value 65535, which disables parallel processing. MAXRGN>0 is not allowed with PARLIM(65535). The transaction definition was not imported. This should not occur if the definition was created by a valid export or by an IBM-supplied utility. |
| 3D              | FP=N/EMHBSZ GT 0 CONFLICT      | Non-Fast Path FP(N) conflicts with Fast Path attribute EMHBSZ>0. The transaction definition was not imported. This should not occur if the definition was created by a valid export or by an IBM-supplied utility.  |
| 3E              | FP=N/FP=E PGM CONFLICT         | Non-Fast Path FP(N) option conflicts with program defined as Fast Path exclusive FP(E). The transaction definition was not imported.  |

Table 340. Completion codes for the **IMPORT** command (continued)

| Completion code | Completion code text            | Meaning  |
|-----------------|---------------------------------|--|
| 3F              | FP=P/BMPTYPE=Y CONFLICT         | Fast Path potential FP(P) option conflicts with program defined as BMP type BMPTYPE(Y). The transaction definition was not imported.   |
| 40              | PARLIM/SCHDTYPE=SERIAL CONFLICT | PARLIM value is something other than 65535 and the program is defined as SCHDTYPE(SERIAL). The transaction definition was not imported.  |
| 41              | FP=E OR P/RECOVER=N CONFLICT    | Fast Path exclusive FP(E) or Fast Path potential FP(P) option conflicts with recovery RECOVER(N) option. The transaction definition was not imported. This should not occur if the definition was created by a valid export or by an IBM-supplied utility.   |
| 42              | FP=E OR P/RESP=N CONFLICT       | Fast Path exclusive FP(E) or Fast Path potential FP(P) option conflicts with response mode RESP(N) option. The transaction definition was not imported. This should not occur if the definition was created by a valid export or by an IBM-supplied utility. |
| 43              | GPSB=Y/DOPT=Y CONFLICT          | Generated PSB GPSB(Y) option conflicts with the dynamic DOPT(Y) option. The program definition was not imported. This should not occur if the definition was created by a valid export or by an IBM-supplied utility.  |
| 44              | TRANSACTION BUSY                | The <b>IMPORT</b> command cannot be processed for the resource because the transaction is currently being scheduled.   |
| 45              | INVALID SIDR VALUE              | Remote system ID SIDR value is invalid. The transaction definition was not imported.   |
| 46              | GPSB=N/LANG CONFLICT            | Generated PSB option N GPSB(N) conflicts with the language option LANG(). The program definition is not imported. This should not occur if the definition was created by a valid export or by an IBM-supplied utility.                                       |
| 47              | GPSB=Y/RESIDENT=Y CONFLICT      | Generated PSB GPSB(Y) option conflicts with the resident RESIDENT(Y) option. The program definition is not imported. This should not occur if the definition was created by a valid export or by an IBM-supplied utility.                                    |
| 48              | NOT ALLOWED FOR IMS RESOURCE    | Command is not allowed for IMS descriptors or IMS resources. DFSDSDB1, DFSDSPG1, DBFDSRT1, and DFSDSTR1 are examples of IMS descriptors. DBF#FPU0 is an example of an IMS resource.  |
| 49              | INQ=N/RECOVER=N CONFLICT        | Inquiry INQ(N) option conflicts with recover RECOVER(N) option. The transaction definition was not imported. This should not occur if the definition was created by a valid export or by an IBM-supplied utility.  |

Table 340. Completion codes for the IMPORT command (continued)

| Completion code | Completion code text           | Meaning   |
|-----------------|--------------------------------|---|
| 4A              | IN USE                         | Transaction is in use. Queuing is in progress, either terminal input or a program-to-program switch.  |
| 4B              | INVALID LCT VALUE              | Limit count LCT value is invalid. The transaction definition was not imported. This should not occur if the definition was created by a valid export or by an IBM-supplied utility.   |
| 4D              | INVALID LPRI INVALID           | Limit priority LPRI value is invalid. The transaction definition was not imported. This should not occur if the definition was created by a valid export or by an IBM-supplied utility.   |
| 4E              | LTERM ALREADY EXISTS           | An LTERM already exists by the same name. The transaction definition was not imported.  |
| 4F              | INVALID MAXRGN VALUE           | Maximum region count value is invalid. The transaction definition was not imported. This should not occur if the definition was created by a valid export or by an IBM-supplied utility.  |
| 51              | NO RESOURCE STRUCTURE          | The resource structure is not available. The resource could not be registered with RM. The resource definition was not imported.  |
| 52              | RESOURCE STRUCTURE FULL        | The resource structure is full. The resource could not be registered with RM. The resource definition was not imported.   |
| 55              | NO FAST PATH INSTALLED         | Fast Path is not installed. The resource or descriptor definition was not imported.   |
| 58              | IMS NOT REGISTERED TO RM       | IMS is not registered to RM.  |
| 59              | MSC KEYWORD/FP=E PGM CONFLICT  | MSC MSNAME or SIDR/SIDL value conflicts with program defined as Fast Path exclusive FP(E). The transaction definition was not imported.   |
| 5A              | INVALID MSNAME                 | MSNAME is invalid. The transaction definition was not imported.   |
| 5B              | MSNAME ALREADY EXISTS          | An MSNAME with the same name exists. The transaction definition was not imported.   |
| 5E              | MAXRGN GT 0/SERIAL=Y CONFLICT  | Serial SERIAL(Y) option conflicts with maximum region count MAXRGN > 0 value. The transaction definition was not imported. This should not occur if the definition was created by a valid export or by an IBM-supplied utility. |
| 5F              | INVALID CHARACTERS IN NAME     | Resource or descriptor name is invalid because it contains an invalid character. The resource or descriptor definition was not imported.  |
| 60              | IMODULE GETMAIN storage error. |   |
| 61              | DFSBCB STORAGE ERROR           | DFSBCB storage error. Could not get storage for DDIR, PDIR, RCTE, or SMB control block. The resource or descriptor definition was not imported.   |



Table 340. Completion codes for the **IMPORT** command (continued)

| Completion code | Completion code text            | Meaning   |
|-----------------|---------------------------------|---|
| 62              | HIOP storage error.             |   |
| 63              | WKAP storage error.             |   |
| 64              | GETSTOR STORAGE ERROR           | DFSPPOOL storage error. Could not get storage from the CMDP pool. The resource or descriptor was not imported.  |
| 65              | DMB POOL STORAGE ERROR          | DMB pool storage error. The command failed because of DMB pool storage request failure.   |
| 67              | NO PGM DEFINED                  | No program PGM() defined. PGM() is required for transactions that are not remote REMOTE(N) and for routing codes. The definition was not imported. This should not occur if the definition was created by a valid export or by an IBM-supplied utility.   |
| 68              | INVALID NPRI VALUE              | Normal priority NPRI value is invalid. The transaction definition was not imported. This should not occur if the definition was created by a valid export or by an IBM-supplied utility.  |
| 69              | INVALID PARLIM VALUE            | Parallel limit count PARLIM value is invalid. The transaction definition was not imported. This should not occur if the definition was created by a valid export or by an IBM-supplied utility.   |
| 6A              | FP=P/FP=E PGM CONFLICT          | Fast Path potential FP(P) transaction definition conflicts with program already defined as Fast Path exclusive FP(E). The transaction definition was not imported.  |
| 6B              | PARLIM/SERIAL=Y CONFLICT        | Serial SERIAL(Y) option conflicts with parallel limit PARLIM value. The transaction definition was not imported. This should not occur if the definition was created by a valid export or by an IBM-supplied utility.   |
| 6C              | NOT ALLOWED FOR HALDB PARTITION | When processing a database definition, the <b>IMPORT</b> command attempted to change the resident attribute of a HALDB partition. HALDB partition definitions are not exported to an RDDS or the IMSRSC repository. When the database definition was exported, the database must not have been a HALDB partition. |
| 6D              | INVALID PROGRAM NAME            | Program specified does not exist. The transaction or route code definition was not imported.  |
| 73              | PROGRAM SCHEDULED               | Program is scheduled.   |
| 75              | INVALID PLCTTIME VALUE          | Parallel limit count time is invalid. The transaction definition was not imported. This should not occur if the definition was created by a valid export or by a utility supplied by IBM.   |
| 77              | DEPENDENT REGIONS ACTIVE        | One or more dependent regions are scheduled against the database, or one or more areas are open. The DEDB cannot be updated.  |

Table 340. Completion codes for the IMPORT command (continued)

| Completion code | Completion code text             | Meaning   |
|-----------------|----------------------------------|---|
| 79              | REMOTE/SIDR/SIDL/MSNAME CONFLICT | Remote REMOTE(Y) option requires MSC MSNAME or SIDR/SIDL value. The transaction definition was not imported. This should not occur if the definition was created by a valid export or by an IBM-supplied utility.   |
| 7A              | RTC/FP=N PGM CONFLICT            | The program specified is defined as non-Fast Path FP(N). The route code definition was not imported.  |
| 7E              | INVALID SPASZ VALUE              | SPA size is invalid. The transaction definition was not imported. This should not occur if the definition was created by a valid export or by an IBM-supplied utility.  |
| 80              | DATASET ERROR                    | <p>Function (8 characters), ddname (8 characters), return code (8 bytes), and error detail (8 characters).</p> <p>Function can be one of the following:</p> <p><b>BLDL</b><br/>Data set BLDL error.</p> <p><b>BUSY</b><br/>The data set is busy. The detail contains the job name that has the data set.</p> <p><b>DIR</b><br/>Data set directory error.</p> <p><b>EMPTY</b><br/>Library is empty.</p> <p><b>ENQUEUE</b><br/>Data set enqueue error.</p> <p><b>EOF</b><br/>Data set end-of-file (EOF) error.</p> <p><b>OPEN</b><br/>Data set open error. Error detail can be 'DLS REG'.</p> <p><b>READ</b><br/>Data set read error.</p> <p><b>WRITE</b><br/>Data set write error.</p> <p>Ddname can be the DFSDIRC, the ddname of the IMS directory data set or DFSSTDI, the ddname of the staging data set of the IMS directory.</p> <p>Return code is the data set service return code.</p> <p>Reason code is the data set service reason code.</p> |
| 83              | INVALID SIDL VALUE               | Local system ID SIDL value is invalid. The transaction definition was not imported.   |
| 85              | SUSPENDED                        | Transaction is on the suspend queue.  |
| 87              | TRAN QUEUEING                    | Transaction has messages queued in a non-shared-queues environment.   |

Table 340. Completion codes for the IMPORT command (continued)

| Completion code | Completion code text             | Meaning   |
|-----------------|----------------------------------|---|
| 89              | TRAN SCHEDULED                   | Transaction is scheduled.   |
| 8A              | WILDCARD PARAMETER NOT SUPPORTED | Resource or descriptor name is invalid because it contains a wildcard parameter. The definition was not imported. This should not occur if the definition was created by a valid export or by an IBM-supplied utility.  |
| 90              | INTERNAL ERROR                   | An IMS internal error occurred. The definition was not imported.  |
| 93              | RESERVED NAME                    | Resource or descriptor name is reserved. For example, name starts with DFS (except for DFSSAMxx or DFSIVPxx), or is an IMS reserved name such as BASICEDT or WTOR. The definition was not imported. This should not occur if the definition was created by a valid export or by an IBM-supplied utility.  |
| 94              | RM REQUEST ERROR                 | An RM request error occurred. The resource could not be registered with RM. The resource definition was not imported.   |
| 97              | DOPT=Y/LANG CONFLICT             | The program was defined as DOPT(Y) and a language other than Java was defined. The program definition was not imported. This should not occur if the definition was created by a valid export or by an IBM-supplied utility.  |
| 98              | CQS REQUEST ERROR                | A CQS request error occurred. The resource could not be registered with RM. The resource definition was not imported.   |
| B0              | RESOURCE DEFINITION ERROR        | The resource exists as another resource type in the RM structure. The resource definition was not imported.   |
| B1              | RESOURCE STATE ERROR             | Resource type (8 characters), resource name (8 characters), error detail (16 characters).<br><br>The resource name is the name of the resource as it is defined to IMS, such as the database name, the program name, or the transaction name.<br><br>The error detail can be one of the following:<br><b>AREA OPEN</b><br>An area associated with the FP DEDB is open.<br><b>AREA STARTED</b><br>An area associated with the FP DEDB is started.<br><b>DATABASE <i>dbname</i> ALTER INCOMPLETE</b><br>Alter processing is not complete for a HALDB database. After alter processing completes, retry the <b>INITIATE OLC</b> command.<br><br>Error details continued in next row. |

Table 340. Completion codes for the *IMPORT* command (continued)

| Completion code | Completion code text                | Meaning  |
|-----------------|-------------------------------------|--|
| B1              | RESOURCE STATE ERROR<br>(continued) | <p><b>DBD ACTIVE</b><br/>A <b>/DBDUMP</b> command is active for the database.</p> <p><b>DBR ACTIVE</b><br/>A <b>/DBRECOVERY</b> command is active for the database.</p> <p><b>DEP REGS ACTIVE</b><br/>Dependent regions using the FP DEDB are active.</p> <p>Error details continued in next row.</p>  |
| B1              | RESOURCE STATE ERROR<br>(continued) | <p>Error detail (continued):</p> <p><b>INTERNAL ERROR</b><br/>The resource control block is not found in the active IMS, or the resource control block exists. These are internal errors that should not occur.</p> <p><b>IN USE</b><br/>The resource is in use.</p> <p>A transaction has queuing in progress (either terminal input program-to-program switch).</p> <p>A database is in use.</p> <p><b>PSB SCHEDULED</b><br/>A program referencing a database to be changed or deleted is scheduled.</p> <p><b>QUEUEING</b><br/>Messages are queued to the transaction or program.</p> <p><b>SCHEDULED</b><br/>The named resource (a transaction or program to be changed or deleted, or a program referencing a database to be changed or deleted) is scheduled.</p> <p><b>SUSPENDED</b><br/>The transaction to be changed or deleted is on the suspend queue.</p> |
| B2              | IMS STATE ERROR                     | <p>IMS state error (32 characters). The IMS state can be one of the following:</p> <p><b>CHECKPOINT IN PROGRESS</b><br/>This IMS has checkpoint in progress.</p> <p><b>NOT-REACHABLE</b><br/>The online change phase is rejected because this IMS is NOT-REACHABLE. The SCI on the OS image where this IMS is active is down. Restart the SCI and reissue the <b>IMPORT DEFN SOURCE (CATALOG)</b> command.</p>   |

Table 340. Completion codes for the IMPORT command (continued)

| Completion code | Completion code text           | Meaning   |
|-----------------|--------------------------------|---|
| B2              | IMS STATE ERROR<br>(continued) | IMS state error (32 characters). The IMS state can be one of the following:<br><br><b>RESOLVE DB INDOUBTS</b><br>This IMS has DB indoubts. You must resolve the DB indoubts either by reconnecting the coordinator controller and IMS or by using an operator command.<br><br><b>RESTART IN PROGRESS</b><br>This IMS has restart in progress. |
| B3              | TRAN ELIGIBLE FOR SCHEDULING   | Transaction is eligible for scheduling and cannot be updated. You might need to stop the transaction with an <b>UPDATE TRAN STOP(Q, SCHD)</b> command before attempting the import again.   |
| B5              | ROUTING CODE ALREADY EXISTS    | Transaction update failed because the Fast Path exclusive FP(E) option conflicts with a routing code that already exists by that transaction name.  |
| B6              | LATCH ERROR                    | Unable to obtain latch. The resource or descriptor definition was not imported.   |
| B9              | LANG REQUIRED                  | Program is defined as GPSB(Y) but a language LANG() value was not defined. The program definition was not imported. This should not occur if the definition was created by a valid export or by an IBM-supplied utility.  |
| BA              | NOT ALLOWED FOR MRQ PSB        | An attribute was defined that is not supported for the MRQ PSB. The program definition was not imported. This should not occur if the definition was created by a valid export or by an IBM-supplied utility.   |
| BC              | MAX 32767 DB EXCEEDED          | 32767 databases already exist. A maximum of 32767 databases are allowed. The database definition was not imported.  |
| BD              | INVALID DB ACCESS TYPE         | The database access type is invalid. The database definition was not imported. This should not occur if the definition was created by a valid export or by an IBM-supplied utility.   |
| BE              | INVALID CPRI VALUE             | The current priority CPRI value is invalid. The transaction definition was not imported. This should not occur if the definition was created by a valid export or by an IBM-supplied utility.   |
| D6              | DATABASE IN USE                | Database in use. The DEDB cannot be changed because the DEDB is in use in a region.   |
| DE              | ACBLIB READ FAILURE            | An error occurred trying to read ACBLIB. The definition was not imported.   |

Table 340. Completion codes for the **IMPORT** command (continued)

| Completion code | Completion code text            | Meaning  |
|-----------------|---------------------------------|--|
| E1              | DB MUST BE STOPPED AND OFFLINE  | The database must be stopped and taken offline in order for the attribute to be changed. You might need to issue a <b>/DBR DB</b> command or an <b>UPDATE DB STOP(ACCESS)</b> command to stop the database and take it offline before issuing the <b>IMPORT DEFN</b> command.  |
| E2              | PARALLEL DB OPEN NOT COMPLETE   | Restart parallel DB open is not complete. The command is not processed because the restart parallel DB open is not complete for the database.  |
| 140             | NO TRAN INPUT EDIT RTN TBL      | An edit routine was defined for the transaction, but an edit routine table was never built. The transaction definition was not imported.   |
| 141             | LOAD FOR EDIT ROUTINE FAILED    | An edit routine was defined for the transaction, but the edit routine could not be loaded. The transaction definition was not imported.  |
| 143             | NO IMPORT - FPE TRAN ERROR      | The routing code is associated with a Fast Path exclusive transaction. An error occurred importing the transaction, so the routing code definition was not imported.   |
| 144             | NO STORAGE FOR RM REG TRAN LIST | No storage was available to build the list of transactions to register with RM. The transaction definition was not imported.   |
| 145             | MESSAGE IN PROGRESS ACROSS LINK | Transaction update failed because a message for the transaction is in progress across the MSC link.  |
| 1D1             | NO REPOSITORY DEFINED           | No repository is defined.  |
| 1D4             | REPOSITORY MEMBER IN USE        | The repository member for the specified resource is in use.  |
| 1D6             | REPOSITORY ERROR                | Repository error.  |
| 1D8             | CHANGE LIST IN USE              | The <b>IMPORT DEFN SOURCE(REPO)</b> command could not be completed because the change list for an IMS is in use and not accessible to be updated. If it is a residual change list, issue the <b>DELETE DEFN TARGET(REPO) TYPE(CHGLIST)</b> command to delete the change list and then retry the command, or issue the <b>IMPORT</b> command with the <b>SCOPE(ACTIVE)</b> keyword. If the IMS whose change list is not accessible is being restarted, issue the <b>IMPORT</b> command again. |

## Examples

The following are examples of the **IMPORT** command:

### Example 1 for **IMPORT** command

TSO SPOC input:

```
IMPORT DEFN SOURCE(RDDS) RDDSDSN(IMSPLEX1.RDDS.DEFN)
```

TSO SPOC output:

```
Log for: IMPORT DEFN SOURCE(RDDS) RDDSDSN(IMPSPLEX1.RDDS.DEFN)

IMSpIex . . . . . : PLEX1
Routing . . . . . :
Start time . . . . : 2007.074 12:40:02.30
Stop time . . . . . : 2007.074 12:40:03.32
Return code . . . . : 00000000
Reason code . . . . : 00000000
Reason text . . . . :
Command master. . . : IMS2

MbrName  Messages
-----
IMS1     DFS3405I IMPORT COMMAND COMPLETE FOR ALL , DSN=IMPSPLEX1.RDDS.DEFN
IMS2     DFS3405I IMPORT COMMAND COMPLETE FOR ALL , DSN=IMPSPLEX1.RDDS.DEFN
```

**Explanation:** The **IMPORT** command is routed to two IMS systems: IMS1 and IMS2. Each IMS successfully imports all of the resource and descriptor definitions from RDDS IMPSPLEX1.RDDS.DEFN. Because **OPTION(ALLRSP)** is not specified, the list of imported resources is not returned.

**Note:** Each DFS3405I message is encapsulated in a single set of <msg> </msg> tags and is shown on the same TSO SPOC screen as the return and reason codes. If the message does not fit on one screen, you might need to scroll right to view the entire message.

### **Example 2 for IMPORT command**

TSO SPOC input:

```
IMPORT DEFN SOURCE(RDDS) RDDSDSN(IMPSPLEX1.RDDS.DEFN) OPTION(ALLRSP)
```

TSO SPOC output:

```
Name      Type      MbrName  CC ImpType
DEDBJN01  DB        IMS2     0  CREATE
DBDFLT    DBDESC    IMS2     0  CREATE
CDEBS     PGM       IMS2     0  CREATE
PGMDFLT   PGMDDESC  IMS2     0  CREATE
SMQFP5A   RTC       IMS2     0  CREATE
RTCDFLT   RTCDESC   IMS2     0  CREATE
CDEBTRN1  TRAN      IMS2     0  CREATE
TRANDFLT  TRANDESC  IMS2     0  CREATE
```

When the **PF4** key is pressed, the following is displayed:

```
Log for: IMPORT DEFN SOURCE(RDDS) RDDSDSN(IMPSPLEX1.RDDS.DEFN) OPTION(ALLRSP)

IMSpIex . . . . . : PLEX1
Routing . . . . . : IMS2
Start time . . . . : 2007.074 12:40:02.30
Stop time . . . . . : 2007.074 12:40:03.32
Return code . . . . : 00000000
Reason code . . . . : 00000000
Reason text . . . . :
Command master. . . : IMS2

MbrName  Messages
-----
IMS2     DFS3405I IMPORT COMMAND COMPLETE FOR ALL , DSN=IMPSPLEX1.RDDS.DEFN
```

**Explanation:** The **IMPORT** command is sent to IMS2. All resources from RDDS IMPSPLEX1.RDDS.DEFN are imported successfully by IMS2. Because **OPTION(ALLRSP)** is specified, a list of imported resources is returned.

### **Example 3 for IMPORT command**

TSO SPOC input:

```
IMPORT DEFN SOURCE(RDDS) RDDSDSN(IMPSPLEX1.RDDS.DEFN) OPTION(ALLRSP)
```

TSO SPOC output:

| Name     | Type     | MbrName | CC | CCText               | ImpType |
|----------|----------|---------|----|----------------------|---------|
| PART     | DB       | IMS1    | 0  |                      | CREATE  |
| PART     | DB       | IMS2    | 0  |                      | CREATE  |
| PARTMAST | DB       | IMS1    | 0  |                      | CREATE  |
| PARTMAST | DB       | IMS2    | 0  |                      | CREATE  |
| TESTDB   | DB       | IMS1    | 0  |                      | CREATE  |
| TESTDB   | DB       | IMS2    | 0  |                      | CREATE  |
| TRND01   | TRAN     | IMS1    | 6D | INVALID PROGRAM NAME |         |
| TRND01   | TRAN     | IMS2    | 0  |                      | CREATE  |
| TRND11   | TRAN     | IMS1    | 0  |                      | CREATE  |
| TRND11   | TRAN     | IMS2    | 0  |                      | CREATE  |
| TRND123  | TRAN     | IMS1    | 0  |                      | CREATE  |
| TRND123  | TRAN     | IMS2    | 0  |                      | CREATE  |
| TRND01   | TRANDESC | IMS1    | 0  |                      | CREATE  |
| TRND01   | TRANDESC | IMS2    | 0  |                      | CREATE  |

When the **PF4** key is pressed, the following is displayed:

```
Log for: IMPORT DEFN SOURCE(RDDS) RDDSDSN(IMSPLEX1.RDDS.DEFN)
```

```

IMSpIex . . . . . : PLEX1
Routing . . . . . :
Start time . . . . : 2007.074 12:40:02.30
Stop time . . . . . : 2007.074 12:40:03.32
Return code . . . . : 0200000C
Reason code . . . . : 00003000
Reason text . . . . : At least one request successful
Command master. . : IMS2

```

| MbrName | Return Code | Reason Code | Description                     |
|---------|-------------|-------------|---------------------------------|
| IMS1    | 0000000C    | 00003000    | At least one request successful |

```

MbrName Messages
-----
IMS1 DFS3405I IMPORT COMMAND COMPLETE FOR SOME, DSN=IMSPLEX1.RDDS.DEFN
IMS2 DFS3405I IMPORT COMMAND COMPLETE FOR ALL, DSN=IMSPLEX1.RDDS.DEFN

```

**Explanation:** The **IMPORT** command is routed to two IMS systems: IMS1 and IMS2. Each IMS imports the resource and descriptor definitions from RDDS IMSPLEX1.RDDS.DEFN. IMS1 failed to import one or more resource or descriptor definitions. IMS2 imported all of the resource and descriptor definitions successfully. Transaction resource TRND01 is not imported at IMS1, because its program name does not exist at IMS1. Because **OPTION(ALLRSP)** is specified, a list of imported resources at IMS1 and IMS2 is returned.

#### Example 4 for **IMPORT** command

TSO SPOC input:

```
IMPORT DEFN SOURCE(RDDS) RDDSDSN(MYDSN.DEFN) OPTION(ABORT,ALLRSP)
```

TSO SPOC output:

| Name     | Type     | MbrName | CC | CCText                   |
|----------|----------|---------|----|--------------------------|
| PART     | DB       | IMS1    | 9  | NO IMPORT - OPTION ABORT |
| PARTMAST | DB       | IMS1    | 9  | NO IMPORT - OPTION ABORT |
| TESTDB   | DB       | IMS1    | 9  | NO IMPORT - OPTION ABORT |
| TRND01   | TRAN     | IMS1    | 6D | INVALID PROGRAM NAME     |
| TRND11   | TRAN     | IMS1    | 9  | NO IMPORT - OPTION ABORT |
| TRND123  | TRAN     | IMS1    | 9  | NO IMPORT - OPTION ABORT |
| TRND01   | TRANDESC | IMS1    | 9  | NO IMPORT - OPTION ABORT |

When the **PF4** key is pressed, the following is displayed:

```
Log for . . : IMPORT DEFN SOURCE(RDDS) RDDSDSN(MYDSN.DEFN) OPTION(...)
```

```

IMSpIex . . . . . : PLEX1
Routing . . . . . :
Start time . . . . : 2009.027 19:34:42.27
Stop time . . . . . : 2009.027 19:34:42.34
Return code . . . . : 0200000C
Reason code . . . . : 00003008
Reason text . . . . : None of the clients were successful.

```



```
Command master. . : IMS1
```

| MbrName | Return Code | Reason Code | Reason text                 |
|---------|-------------|-------------|-----------------------------|
| IMS1    | 0000000C    | 00003004    | No requests were successful |

```
MbrName Messages
```

```
IMS1 DFS3405I IMPORT COMMAND COMPLETE FOR NONE, DSN=MYDSN.DEFN
```

**Explanation:** The **IMPORT** command is sent to IMS1. IMS1 encountered an error when importing resource and descriptor definitions from RDDS MYDSN.DEFN. Transaction resource TRND01 is not imported, because its associated program name does not exist at IMS1. Because **OPTION(ABORT,ALLRSP)** is specified, no resources are imported at IMS1 because of the **ABORT** option, and a response line is returned for each resource processed by the command because of the **ALLRSP** option. The resources that are not imported because of the **ABORT** option have a completion code of 9 and completion code text of "NO IMPORT - OPTION ABORT". If **OPTION(ALLRSP)** is not specified, response lines are only returned for those resources that encountered an import error, such as TRND01 in this example, and response lines are not returned for those resources that have a completion code of 9.

### Example 5 for IMPORT command

TSO SPOC input:

```
IMPORT DEFN SOURCE(RDDS) RDDSDSN(IMSPLEX1.RDDS.DEFN) OPTION(ALLRSP,UPDATE)
```

TSO SPOC output:

| Name     | Type     | MbrName | CC | ImpType |
|----------|----------|---------|----|---------|
| DEDBJN01 | DB       | IMS2    | 0  | CREATE  |
| DBDFLT   | DBDESC   | IMS2    | 0  | CREATE  |
| CDEBS    | PGM      | IMS2    | 0  | UPDATE  |
| PGMDFLT  | PGMDESC  | IMS2    | 0  | CREATE  |
| SMQFP5A  | RTC      | IMS2    | 0  | CREATE  |
| RTCDFLT  | RTCDESC  | IMS2    | 0  | CREATE  |
| CDEBTRN1 | TRAN     | IMS2    | 0  | UPDATE  |
| TRANDFLT | TRANDESC | IMS2    | 0  | CREATE  |

When the **PF4** key is pressed, the following is displayed:

```
Log for: IMPORT DEFN SOURCE(RDDS) RDDSDSN(IMSPLEX1.RDDS.DEFN) OPTION(ALLRSP,UPDATE)
IMSpIex . . . . . : PLEX1
Routing . . . . . :
Start time . . . . : 2007.074 12:40:02.30
Stop time . . . . . : 2007.074 12:40:03.32
Return code . . . . : 00000000
Reason code . . . . : 00000000
Reason text . . . . :
Command master. . : IMS2
```

```
MbrName Messages
```

```
IMS2 DFS3405I IMPORT COMMAND COMPLETE FOR ALL , DSN=IMSPLEX1.RDDS.DEFN
```

OM API input:

```
CMD(IMPORT DEFN SOURCE(RDDS) RDDSDSN(IMSPLEX1.RDDS.DEFN) OPTION(ALLRSP,UPDATE))
```

OM API output:

```
<imsout>
<ctl>
<omname>OM10M </omname>
<omvsn>1.3.0</omvsn>
<xmIvsn>20 </xmIvsn>
<statime>2009.099 00:26:38.776367</statime>
<stotime>2009.099 00:26:38.829881</stotime>
<staseq>C402495EBA42FFA0</staseq>
<stoseq>C402495EC7539267</stoseq>
<rqsttkn1>USRT011 10172638</rqsttkn1>
<rc>00000000</rc>
<rsn>00000000</rsn>
```

```

</ctl>
<cmd>
<master>IMS2      </master>
<userid>USRT011  </userid>
<verb>IMP </verb>
<kwd>DEFN          </kwd>
<input>IMPORT DEFN SOURCE(RDDS) RDDSDSN(IMSPLEX1.RDDS.DEFN)
  OPTION(ALLRSP,UPDATE) </input>
</cmd>
<cmdr sphdr>
<hdr  slbl="NAME" llbl="Name" scope="LCL" sort="a" key="2" scroll="no"
  len="8" dtype="CHAR" align="left" />
<hdr  slbl="TYPE" llbl="Type" scope="LCL" sort="a" key="1" scroll="no"
  len="8" dtype="CHAR" align="left" skipb="yes" />
<hdr  slbl="MBR" llbl="MbrName" scope="LCL" sort="a" key="3" scroll="no"
  len="8" dtype="CHAR" align="left" />
<hdr  slbl="CC" llbl="CC" scope="LCL" sort="n" key="0" scroll="yes"
  len="4" dtype="INT" align="right" />
<hdr  slbl="CCTXT" llbl="CCText" scope="LCL" sort="n" key="0"
  scroll="yes" len="32" dtype="CHAR" align="left" skipb="yes" />
<hdr  slbl="IMPTYPE" llbl="ImpType" scope="LCL" sort="n" key="0"
  scroll="yes" len="8" dtype="CHAR" align="left" skipb="yes" />
<hdr  slbl="OLDDEF" llbl="OldDefault" scope="LCL" sort="n" key="0"
  scroll="yes" len="8" dtype="CHAR" align="left" skipb="yes" />
</cmdr sphdr>
<cmdrsp data>
<rsp>NAME(CDEBTRN1) TYPE(TRAN) MBR(IMS2) CC( 0) IMPTYPE(UPDATE) </rsp>
<rsp>NAME(TRANDFLT) TYPE(TRANDESC) MBR(IMS2) CC( 0) IMPTYPE(CREATE)
</rsp>
<rsp>NAME(DEDBJN01) TYPE(DB) MBR(IMS2) CC( 0) IMPTYPE(CREATE) </rsp>
<rsp>NAME(DBDFLT ) TYPE(DBDESC) MBR(IMS2) CC( 0) IMPTYPE(CREATE)
</rsp>
<rsp>NAME(CDEBS ) TYPE(PGM) MBR(IMS2) CC( 0) IMPTYPE(UPDATE) </rsp>
<rsp>NAME(PGMDFLT ) TYPE(PGMDESC) MBR(IMS2) CC( 0) IMPTYPE(CREATE)
</rsp>
<rsp>NAME(SMQFP5A ) TYPE(RTC) MBR(IMS2) CC( 0) IMPTYPE(CREATE) </rsp>
<rsp>NAME(RTCDFLT ) TYPE(RTCDESC) MBR(IMS2) CC( 0) IMPTYPE(CREATE)
</rsp>
</cmdrsp data>
<msg data>
<mbr name="IMS2 ">
<msg>DFS3405I IMPORT COMMAND COMPLETE FOR ALL , DSN=IMSPLEX1.RDDS.DEFN
</msg>
</mbr>
</msg data>
</imsout>

```

**Explanation:** The **IMPORT** command is sent to IMS IMS2. All resources from RDDS IMSPLEX1.RDDS.DEFN are imported successfully by IMS2. Because OPTION(ALLRSP) is specified, a list of imported resources is returned. In this example, runtime resource definitions for program CDEBS and transaction CDEBTRAN already exist. Because OPTION(UPDATE) is specified, the exiting runtime resource definitions for those resources are replaced. New runtime resource definitions are created for the remaining resources and descriptors.

#### Example 6 for IMPORT command

TSO SPOC input:

```
IMPORT DEFN SOURCE(RDDS) RDDSDSN(MYDSN.DEFN) OPTION(UPDATE,ABORT)
```

TSO SPOC output:

| Name   | Type | MbrName | CC | CCText               |
|--------|------|---------|----|----------------------|
| TRND01 | TRAN | SYS3    | 6D | INVALID PROGRAM NAME |

When the **PF4** key is pressed, the following is displayed:

```

Log for . . : IMPORT DEFN SOURCE(RDDS) RDDSDSN(MYDSN.DEFN) OPT... More:  +>

IMSPlex . . . . . : PLEX1
Routing . . . . . :
Start time. . . . : 2011.124 15:59:03.26
Stop time . . . . : 2011.124 15:59:03.41
Return code . . . : 0200000C
Reason code . . . : 00003000
Reason text . . . : At least one request was successful.

```

Command master. . : IMS2

| MbrName | Return Code | Reason Code | Reason text                 |
|---------|-------------|-------------|-----------------------------|
| IMS1    | 0000000C    | 00003004    | No requests were successful |

MbrName Messages

|      |          |  |
|------|----------|--|
| IMS2 | DFS3405I | IMPORT COMMAND COMPLETE FOR ALL , DSN=MYDSN.DEFN |
| IMS1 | DFS3405I | IMPORT COMMAND COMPLETE FOR NONE, DSN=MYDSN.DEFN |

#### OM API input:

```
CMD(IMPORT DEFN SOURCE(RDDS) RDDSDSN(MYDSN.DEFN) OPTION(UPDATE,ABORT))
```

#### OM API output:

```
<imsout>
<ctl>
<omname>OM10M </omname>
<omvsn>1.5.0</omvsn>
<xmlvsn>20 </xmlvsn>
<statime>2011.124 22:59:03.358498</statime>
<stotime>2011.124 22:59:03.407697</stotime>
<staseq>C7B8B7CB3D422A2C</staseq>
<stoseq>C7B8B7CB49451F2C</stoseq>
<rqsttkn1>USRT011 10155903</rqsttkn1>
<rc>0200000C</rc>
<rsn>00003000</rsn>
<rsnmsg>CSLN023I</rsnmsg>
<rsntxt>At least one request was successful.</rsntxt>
</ctl>
<cmderr>
<mbr name="IMS1 ">
<typ>IMS </typ>
<styp>DBDC </styp>
<rc>0000000C</rc>
<rsn>00003004</rsn>
<rsntxt>No requests were successful</rsntxt>
</mbr>
</cmderr>
<cmd>
<master>IMS2 </master>
<userid>USRT011 </userid>
<verb>IMP </verb>
<kwd>DEFN </kwd>
<input>IMPORT DEFN SOURCE(RDDS) RDDSDSN(MYDSN.DEFN)
OPTION(UPDATE,ABORT) </input>
</cmd>
<cmdrsphdr>
<hdr slbl="NAME" llbl="Name" scope="LCL" sort="a" key="2" scroll="no"
len="8" dtype="CHAR" align="left" />
<hdr slbl="TYPE" llbl="Type" scope="LCL" sort="a" key="1" scroll="no"
len="8" dtype="CHAR" align="left" skipb="yes" />
<hdr slbl="MBR" llbl="MbrName" scope="LCL" sort="a" key="3" scroll="no"
len="8" dtype="CHAR" align="left" />
<hdr slbl="CC" llbl="CC" scope="LCL" sort="n" key="0" scroll="yes"
len="4" dtype="INT" align="right" skipb="no" />
<hdr slbl="CCTXT" llbl="CCText" scope="LCL" sort="n" key="0"
scroll="yes" len="32" dtype="CHAR" align="left" skipb="yes" />
<hdr slbl="ERRT" llbl="ErrorText" scope="LCL" sort="n" key="0"
scroll="yes" len="*" dtype="CHAR" skipb="yes" align="left" />
<hdr slbl="IMPTYPE" llbl="ImpType" scope="LCL" sort="n" key="0"
scroll="yes" len="8" dtype="CHAR" align="left" skipb="yes" />
<hdr slbl="OLDDEF" llbl="OldDefault" scope="LCL" sort="n" key="0"
scroll="yes" len="8" dtype="CHAR" align="left" skipb="yes" />
</cmdrsphdr>
<cmdrspdata>
<rsp>NAME(TRND01 ) TYPE(TRAN) MBR(SYS3 ) CC( 6D) CCTXT(INVALID PROGRAM NAME) </
rsp>
</cmdrspdata>
<msgdata>
<mbr name="IMS2 ">
<msg>DFS3405I IMPORT COMMAND COMPLETE FOR ALL , DSN=MYDSN.DEFN
</msg>
</mbr>
<mbr name="IMS1 ">
<msg>DFS3405I IMPORT COMMAND COMPLETE FOR NONE, DSN=MYDSN.DEFN
```

```

</msg>
</mbi>
</msgdata>
</imsout>

```

**Explanation:** The **IMPORT** command is sent to two IMS subsystems: IMS1 and IMS2. IMS1 encountered an error when importing resource and descriptor definitions from RDDS MYDSN.DEFN. Transaction resource TRND01 is not imported at IMS1 because the program specified in the transaction definition does not exist on IMS1. Because **OPTION(ABORT)** is specified, no resources are imported at IMS1. The command is successful at IMS2. Because **OPTION(ALLRSP)** is not specified, a list of resource names is not returned for IMS2.

**Example 7 for IMPORT command**

The following example consists of three separate commands.

TSO SPOC input:

```
QRY TRAN NAME(SKS1,SKS2,TRANA) SHOW(TIMESTAMP)
```

TSO SPOC output:

```

Response for: QRY TRAN NAME(SKS1,SKS2,TRANA) SHOW(TIMESTAMP)
Trancode MbrName  CC CCText          LTimeAccess
SKS1     IMS1       0                  2011.130 11:55:16.02
SKS2     IMS1       0
TRANA    IMS1      10 NO RESOURCES FOUND

Response for: QRY TRAN NAME(SKS1,SKS2,TRANA) SHOW(TIMESTAMP) More: <
Trancode MbrName  LTimeUpdate      LTimeCreate      LTimeImport
SKS1     IMS1     2011.130 12:02:17.44 2011.130 11:49:11.01
SKS2     IMS1     2011.130 11:49:11.01
TRANA    IMS1

```

**Explanation:** The **QRY TRAN SHOW(TIMESTAMP)** command is issued to display the current time stamp values for transactions SKS1, SKS2, and TRANA. Transactions SKS1 and SKS2 exist on IMS IMS1. An access time, an update time, and a create time are displayed for SKS1. A create time is displayed for SKS2. The import time fields are blank for both SKS1 and SKS2. Transaction TRANA does not exist on IMS IMS1.

TSO SPOC input:

```
IMPORT DEFN SOURCE(RDDSDSN) NAME(SKS1,SKS2,TRANA) RDDSDSN(NONSYS.RDDSDSN) OPTION(UPDATE)
```

TSO SPOC output:

```

Response for: IMPORT DEFN SOURCE(RDDSDSN) NAME(SKS1,SKS2,TRANA) ...
Name      Type      MbrName  CC ImpType
SKS1     TRAN      IMS1     0 UPDATE
SKS2     TRAN      IMS1     0
TRANA    TRAN      IMS1     0 CREATE

```

When the **PF4** key is pressed, the following is displayed:

```

Log for . . : IMPORT DEFN SOURCE(RDDSDSN) NAME(SKS1,SKS2,TRANA) ... More:

IMSpIex . . . . . : PLEX1
Routing . . . . . :
Start time. . . . : 2011.130 12:07:27.27
Stop time . . . . : 2011.130 12:07:27.32
Return code . . . : 00000000
Reason code . . . : 00000000
Reason text . . . :
Command master. . : IMS1

MbrName  Messages
-----
IMS1     DFS3405I IMPORT COMMAND COMPLETE FOR ALL , DSN=NONSYS.RDDSDSN

```

OM API input:

```
CMD(IMPORT DEFN SOURCE(RDDS) NAME(SKS1,SKS2,TRANA) RDDSDSN(NONSYS.RDDS1)
OPTION(UPDATE))
```

OM API output:

```
<imsout>
<ctl>
<omname>OM10M </omname>
<omvsn>1.5.0</omvsn>
<xmlvsn>20 </xmlvsn>
<statime>2011.130 19:07:27.297021</statime>
<stotime>2011.130 19:07:27.323045</stotime>
<staseq>C7C00F37B01FDCE7</staseq>
<stoseq>C7C00F37B67A5CAC</stoseq>
<rqsttkn1>USRT011 10120727</rqsttkn1>
<rc>00000000</rc>
<rsn>00000000</rsn>
</ctl>
<cmd>
<master>IMS1 </master>
<userid>USRT011 </userid>
<verb>IMP </verb>
<kwd>DEFN </kwd>
<input>IMPORT DEFN SOURCE(RDDS) NAME(SKS1,SKS2,TRANA)
RDDSDSN(NONSYS.RDDS1) OPTION(UPDATE) </input>
</cmd>
<cmdrsphdr>
<hdr slbl="NAME" llbl="Name" scope="LCL" sort="a" key="2" scroll="no"
len="8" dtype="CHAR" align="left" />
<hdr slbl="TYPE" llbl="Type" scope="LCL" sort="a" key="1" scroll="no"
len="8" dtype="CHAR" align="left" skipb="yes" />
<hdr slbl="MBR" llbl="MbrName" scope="LCL" sort="a" key="3" scroll="no"
len="8" dtype="CHAR" align="left" />
<hdr slbl="CC" llbl="CC" scope="LCL" sort="n" key="0" scroll="yes"
len="4" dtype="INT" align="right" skipb="no" />
<hdr slbl="CCTXT" llbl="CCText" scope="LCL" sort="n" key="0"
scroll="yes" len="32" dtype="CHAR" align="left" skipb="yes" />
<hdr slbl="ERRRT" llbl="ErrorText" scope="LCL" sort="n" key="0"
scroll="yes" len="*" dtype="CHAR" skipb="yes" align="left" />
<hdr slbl="IMPTYPE" llbl="ImpType" scope="LCL" sort="n" key="0"
scroll="yes" len="8" dtype="CHAR" align="left" skipb="yes" />
<hdr slbl="OLDDEF" llbl="OldDefault" scope="LCL" sort="n" key="0"
scroll="yes" len="8" dtype="CHAR" align="left" skipb="yes" />
</cmdrsphdr>
<cmdrspdata>
<rsp>NAME(SKS1 ) TYPE(TRAN) MBR(IMS1 ) CC( 0) IMPTYPE(UPDATE)
</rsp>
<rsp>NAME(SKS2 ) TYPE(TRAN) MBR(IMS1 ) CC( 0) IMPTYPE( )
</rsp>
<rsp>NAME(TRANA ) TYPE(TRAN) MBR(IMS1 ) CC( 0) IMPTYPE(CREATE)
</rsp>
</cmdrspdata>
<msgdata>
<mbr name="IMS1 ">
<msg>DFS3405I IMPORT COMMAND COMPLETE FOR ALL , DSN=NONSYS.RDDS1
</msg>
</mbr>
</msgdata>
</imsout>
```

**Explanation:** The **IMPORT DEFN** command is issued to import definitions for transactions SKS1, SKS2, and TRANA from RDDS NONSYS.RDDS1. A runtime resource definition for SKS1 already exists in IMS IMS1. One or more of the attribute values in the imported definition differ from the attribute values in the existing runtime definition, so the runtime definition is replaced with the attribute values from the imported definition, and the import type is set to UPDATE. A runtime resource definition for SKS2 already exists in IMS IMS1. The attribute values in the imported definition are the same as the attribute values in the existing runtime definition, so the import type is set to UPDATE. A runtime resource definition does not exist for TRANA, so a new runtime definition is created and the import type is set to CREATE.

TSO SPOC input:

```
QRY TRAN NAME(SKS1,SKS2,TRANA) SHOW(TIMESTAMP)
```

TSO SPOC output:

```

Response for: QRY TRAN NAME(SKS1,TRANA) SHOW(TIMESTAMP)
  File Action Manage resources SPOC View Options Help
-----
PLEX1                IMS Single Point of Control
Command ==>

----- Plex . .      Route . .      Wait . .
Response for: QRY TRAN NAME(SKS1,SKS2,TRANA) SHOW(TIMESTAMP)
Trancode MbrName    CC LTimeAccess      LTimeUpdate
SKS1     IMS1       0 2011.130 11:55:16.02 2011.130 12:07:27.29
SKS2     IMS1       0
TRANA    IMS1       0

Response for: QRY TRAN NAME(SKS1,SKS2,TRANA) SHOW(TIMESTAMP)      More: <
Trancode MbrName    LTimeCreate      LTimeImport
SKS1     IMS1       2011.130 11:49:11.01 2011.130 12:07:27.29
SKS2     IMS1       2011.130 11:49:11.01 2011.130 12:07:27.29
TRANA    IMS1       2011.130 11:55:16.02 2011.130 12:07:27.29

```

**Explanation:** After the **IMPORT** command is completed, the **QRY TRAN SHOW(TIMESTAMP)** command is issued again to display the current time stamp values for transactions SKS1, SKS2, and TRANA. The existing runtime definition for SKS1 was replaced by the **IMPORT** command. Both the import time stamp and the update time stamp were set to the time that the **IMPORT** command was received by OM. The access time stamp and create time stamp were not changed. The existing runtime definition for SKS2 was unchanged. The import time stamp for SKS2 was set to the time that the **IMPORT** command was received by OM. The update time stamp, access time stamp, and create time stamp were unchanged. The **IMPORT** command created a runtime definition for TRANA. The import time stamp was set to the time that the **IMPORT** command was received by OM. The create time stamp was obtained from the imported definition and stored in the new runtime definition.

#### **Example 8 for IMPORT command**

TSO SPOC input:

```
IMPORT DEFN SOURCE(REPO) NAME(TRANA,DBA,RTCA,PGMA) TYPE(ALL) SCOPE(ACTIVE)
```

TSO SPOC output:

| Name  | Type | MbrName | CC | ImpType |
|-------|------|---------|----|---------|
| DBA   | DB   | IMS2    | 0  | CREATE  |
| DBA   | DB   | IMS1    | 0  | CREATE  |
| PGMA  | PGM  | IMS2    | 0  | CREATE  |
| PGMA  | PGM  | IMS1    | 0  | CREATE  |
| RTCA  | RTC  | IMS2    | 0  | CREATE  |
| RTCA  | RTC  | IMS1    | 0  | CREATE  |
| TRANA | TRAN | IMS2    | 0  | CREATE  |
| TRANA | TRAN | IMS1    | 0  | CREATE  |

When the **PF4** key is pressed, the following is displayed:

```

Log for . . : IMPORT DEFN SOURCE(REPO) NAME(TRANA,DBA,RTCA,PGM... More: >

IMSpIex . . . . . : PLEX1
Routing . . . . . :
Start time. . . . : 2011.125 11:09:18.82
Stop time . . . . : 2011.125 11:09:19.09
Return code . . . : 00000000
Reason code . . . : 00000000
Reason text . . . :
Command master. . : IMS2

MbrName Messages
-----
IMS2 DFS3406I IMPORT COMMAND COMPLETE FOR ALL, REPOTYPE=IMSRSC,
REPONAME=IMS_REPOS
IMS1 DFS3406I IMPORT COMMAND COMPLETE FOR ALL, REPOTYPE=IMSRSC,
REPONAME=IMS_REPOS

```

OM API input:

```
CMD(IMPORT DEFN SOURCE(REPO) NAME(TRANA,DBA,RTCA,PGMA) TYPE(ALL) SCOPE(ACTIVE))
```

OM API output:

```
<imsout>
<ctl>
<omname>OM10M </omname>
<omvsn>1.5.0</omvsn>
<xmlvsn>20 </xmlvsn>
<stetime>2011.125 18:09:18.842449</stetime>
<stotime>2011.125 18:09:19.093317</stotime>
<staseq>C7B9B8E588A517AE</staseq>
<stoseq>C7B9B8E5C5E45638</stoseq>
<rqsttkn1>USRT011 10110918</rqsttkn1>
<rc>00000000</rc>
<rsn>00000000</rsn>
</ctl>
<cmd>
<master>IMS2 </master>
<userid>USRT011 </userid>
<verb>IMP </verb>
<kwd>DEFN </kwd>
<input>IMPORT DEFN SOURCE(REPO) NAME(TRANA,DBA,RTCA,PGMA) TYPE(ALL)
SCOPE(ACTIVE) </input>
</cmd>
<cmdsphdr>
<hdr sbl="NAME" llbl="Name" scope="LCL" sort="a" key="2" scroll="no"
len="8" dtype="CHAR" align="left" />
<hdr sbl="TYPE" llbl="Type" scope="LCL" sort="a" key="1" scroll="no"
len="8" dtype="CHAR" align="left" skipb="yes" />
<hdr sbl="MBR" llbl="MbrName" scope="LCL" sort="a" key="3" scroll="no"
len="8" dtype="CHAR" align="left" />
<hdr sbl="CC" llbl="CC" scope="LCL" sort="n" key="0" scroll="yes"
len="4" dtype="INT" align="right" skipb="no" />
<hdr sbl="CCTXT" llbl="CCText" scope="LCL" sort="n" key="0"
scroll="yes" len="32" dtype="CHAR" align="left" skipb="yes" />
<hdr sbl="ERRT" llbl="ErrorText" scope="LCL" sort="n" key="0"
scroll="yes" len="*" dtype="CHAR" skipb="yes" align="left" />
<hdr sbl="IMPTYPE" llbl="ImpType" scope="LCL" sort="n" key="0"
scroll="yes" len="8" dtype="CHAR" align="left" skipb="yes" />
<hdr sbl="OLDDEF" llbl="OldDefault" scope="LCL" sort="n" key="0"
scroll="yes" len="8" dtype="CHAR" align="left" skipb="yes" />
</cmdsphdr>
<cmdsdata>
<rsp>NAME(DBA ) TYPE(DB) MBR(IMS2 ) CC( 0) IMPTYPE(CREATE)
</rsp>
<rsp>NAME(PGMA ) TYPE(PGM) MBR(IMS2 ) CC( 0) IMPTYPE(CREATE)
</rsp>
<rsp>NAME(RTCA ) TYPE(RTC) MBR(IMS2 ) CC( 0) IMPTYPE(CREATE)
</rsp>
<rsp>NAME(TRANA ) TYPE(TRAN) MBR(IMS2 ) CC( 0) IMPTYPE(CREATE)
</rsp>
<rsp>NAME(DBA ) TYPE(DB) MBR(IMS1 ) CC( 0) IMPTYPE(CREATE)
</rsp>
<rsp>NAME(PGMA ) TYPE(PGM) MBR(IMS1 ) CC( 0) IMPTYPE(CREATE)
</rsp>
<rsp>NAME(RTCA ) TYPE(RTC) MBR(IMS1 ) CC( 0) IMPTYPE(CREATE)
</rsp>
<rsp>NAME(TRANA ) TYPE(TRAN) MBR(IMS1 ) CC( 0) IMPTYPE(CREATE)
</rsp>
</cmdsdata>
<msgdata>
<mbr name="IMS2 ">
<msg>DFS3406I IMPORT COMMAND COMPLETE FOR ALL, REPOTYPE=IMSRSC,
REPONAME=IMS_REPOS </msg>
</mbr>
<mbr name="IMS1 ">
<msg>DFS3406I IMPORT COMMAND COMPLETE FOR ALL, REPOTYPE=IMSRSC,
REPONAME=IMS_REPOS </msg>
</mbr>
</msgdata>
</imsout>
```

**Explanation:** The runtime resource definitions for the database named DBA, transaction named TRANA, program named PGMA, and routing code named RTCA are imported from the repository as the runtime resource definitions for IMS systems IMS2 and IMS3. The command is processed by all IMS systems that receive the command.

### Example 9 for IMPORT command

TSO SPOC input:

```
IMPORT DEFN SOURCE(REPO) NAME(PGM002,PGM003,PGM004,PGM005,PGM006) SCOPE(ALL)
```

TSO SPOC output:

| Name   | Type | MbrName | CC | ImpType | IMSid |
|--------|------|---------|----|---------|-------|
| PGM002 | PGM  | IMS1    | 0  | CREATE  |       |
| PGM002 | PGM  | IMS1    | 0  | CHGLIST | IMS2  |
| PGM002 | PGM  | IMS1    | 0  | CHGLIST | IMS3  |
| PGM002 | PGM  | IMS1    | 0  | CHGLIST | IMS4  |
| PGM002 | PGM  | IMS1    | 0  | CHGLIST | IMS5  |
| PGM003 | PGM  | IMS1    | 0  | CHGLIST | IMS3  |
| PGM003 | PGM  | IMS1    | 0  | CHGLIST | IMS2  |
| PGM003 | PGM  | IMS1    | 0  | CHGLIST | IMS4  |
| PGM003 | PGM  | IMS1    | 0  | CREATE  |       |
| PGM003 | PGM  | IMS1    | 0  | CHGLIST | IMS5  |
| PGM004 | PGM  | IMS1    | 0  | CHGLIST | IMS2  |
| PGM004 | PGM  | IMS1    | 0  | CHGLIST | IMS4  |
| PGM004 | PGM  | IMS1    | 0  | CHGLIST | IMS3  |
| PGM004 | PGM  | IMS1    | 0  | CREATE  |       |
| PGM004 | PGM  | IMS1    | 0  | CHGLIST | IMS5  |
| PGM005 | PGM  | IMS1    | 0  | CHGLIST | IMS4  |
| PGM005 | PGM  | IMS1    | 0  | CHGLIST | IMS2  |
| PGM005 | PGM  | IMS1    | 0  | CREATE  |       |
| PGM005 | PGM  | IMS1    | 0  | CHGLIST | IMS3  |
| PGM005 | PGM  | IMS1    | 0  | CHGLIST | IMS5  |
| PGM006 | PGM  | IMS1    | 0  | CHGLIST | IMS2  |
| PGM006 | PGM  | IMS1    | 0  | CHGLIST | IMS3  |
| PGM006 | PGM  | IMS1    | 0  | CREATE  |       |
| PGM006 | PGM  | IMS1    | 0  | CHGLIST | IMS4  |
| PGM006 | PGM  | IMS1    | 0  | CHGLIST | IMS5  |

When the **PF4** key is pressed, the following is displayed:

```
Log for . . : IMPORT DEFN SOURCE(REPO) NAME(PGM002,PGM003,PGM004,PGM005,PGM006) SCOPE(ALL)
IMSpIex . . . . : PLEX1
Routing . . . . :
Start time . . . : 2013.189 16:06:50.58
Stop time . . . . : 2013.189 16:06:50.59
Return code . . . : 00000000
Reason code . . . : 00000000
Reason text . . . :
Command master . : IMS1

MbrName  Messages
-----
IMS1     DFS3406I IMPORT COMMAND COMPLETE FOR ALL, REPOTYPE=IMSRSC, REPONAME=IMS_REPOS
```

OM API input:

```
CMD(IMPORT DEFN SOURCE(REPO) NAME(PGM002,PGM003,PGM004,PGM005,PGM006) SCOPE(ALL))
```

OM API output:

```
<?xml version="1.0"?>
<!DOCTYPE imsout SYSTEM "imsout.dtd">
<imsout>
<ctl>
<omname>OM10M </omname>
<omvsn>1.6.0</omvsn>
<xmlvsn>20 </xmlvsn>
<statime>2013.189 23:00:48.499819</statime>
<stotime>2013.189 23:00:48.545610</stotime>
<staseq>CBA184CA6A86B806</staseq>
<stoseq>CBA184CA75B4AD94</stoseq>
<rqsttkn1>USRT005 10160048</rqsttkn1>
<rc>00000000</rc>
<rsn>00000000</rsn>
</ctl>
```



```

<cmd>
<master>IMS1      </master>
<userid>USRT005  </userid>
<verb>IMP </verb>
<kwd>DEFN          </kwd>
<input>IMPORT DEFN SOURCE (REPO)
  NAME (PGM002,PGM003,PGM004,PGM005,PGM006) TYPE (PGM) SCOPE (ALL) </input>
</cmd>
<cmdrsphdr>
<hdr slbl="NAME" llbl="Name" scope="LCL" sort="a" key="2" scroll="no"
len="8" dtype="CHAR" align="left" />
<hdr slbl="TYPE" llbl="Type" scope="LCL" sort="a" key="1" scroll="no"
len="8" dtype="CHAR" align="left" skipb="yes" />
<hdr slbl="MBR" llbl="MbrName" scope="LCL" sort="a" key="3" scroll="no"
len="8" dtype="CHAR" align="left" />
<hdr slbl="CC" llbl="CC" scope="LCL" sort="n" key="0" scroll="yes"
len="4" dtype="INT" align="right" skipb="no" />
<hdr slbl="CCTXT" llbl="CCText" scope="LCL" sort="n" key="0"
scroll="yes" len="32" dtype="CHAR" align="left" skipb="yes" />
<hdr slbl="ERRT" llbl="ErrorText" scope="LCL" sort="n" key="0"
scroll="yes" len="*" dtype="CHAR" skipb="yes" align="left" />
<hdr slbl="IMPTYPE" llbl="ImpType" scope="LCL" sort="n" key="0"
scroll="yes" len="8" dtype="CHAR" align="left" skipb="yes" />
<hdr slbl="IMSID" llbl="IMSid" scope="LCL" sort="n" key="0"
scroll="yes" len="4" dtype="CHAR" align="left" skipb="yes" />
</cmdrsphdr>
<cmdrspdata>
<rsp>NAME (PGM002 ) TYPE (PGM) MBR (IMS1 ) CC ( 0) IMPTYPE (CREATE)
</rsp>
<rsp>NAME (PGM003 ) TYPE (PGM) MBR (IMS1 ) CC ( 0) IMPTYPE (CREATE)
</rsp>
<rsp>NAME (PGM004 ) TYPE (PGM) MBR (IMS1 ) CC ( 0) IMPTYPE (CREATE)
</rsp>
<rsp>NAME (PGM005 ) TYPE (PGM) MBR (IMS1 ) CC ( 0) IMPTYPE (CREATE)
</rsp>
<rsp>NAME (PGM006 ) TYPE (PGM) MBR (IMS1 ) CC ( 0) IMPTYPE (CREATE)
</rsp>
<rsp>NAME (PGM002 ) TYPE (PGM) MBR (IMS1 ) CC ( 0) IMSID (IMS2 )
IMPTYPE (CHGLIST) </rsp>
<rsp>NAME (PGM003 ) TYPE (PGM) MBR (IMS1 ) CC ( 0) IMSID (IMS2 )
IMPTYPE (CHGLIST) </rsp>
<rsp>NAME (PGM004 ) TYPE (PGM) MBR (IMS1 ) CC ( 0) IMSID (IMS2 )
IMPTYPE (CHGLIST) </rsp>
<rsp>NAME (PGM005 ) TYPE (PGM) MBR (IMS1 ) CC ( 0) IMSID (IMS2 )
IMPTYPE (CHGLIST) </rsp>
<rsp>NAME (PGM006 ) TYPE (PGM) MBR (IMS1 ) CC ( 0) IMSID (IMS2 )
IMPTYPE (CHGLIST) </rsp>
<rsp>NAME (PGM002 ) TYPE (PGM) MBR (IMS1 ) CC ( 0) IMSID (IMS3 )
IMPTYPE (CHGLIST) </rsp>
<rsp>NAME (PGM003 ) TYPE (PGM) MBR (IMS1 ) CC ( 0) IMSID (IMS3 )
IMPTYPE (CHGLIST) </rsp>
<rsp>NAME (PGM004 ) TYPE (PGM) MBR (IMS1 ) CC ( 0) IMSID (IMS3 )
IMPTYPE (CHGLIST) </rsp>
<rsp>NAME (PGM005 ) TYPE (PGM) MBR (IMS1 ) CC ( 0) IMSID (IMS3 )
IMPTYPE (CHGLIST) </rsp>
<rsp>NAME (PGM006 ) TYPE (PGM) MBR (IMS1 ) CC ( 0) IMSID (IMS3 )
IMPTYPE (CHGLIST) </rsp>
<rsp>NAME (PGM002 ) TYPE (PGM) MBR (IMS1 ) CC ( 0) IMSID (IMS4 )
IMPTYPE (CHGLIST) </rsp>
<rsp>NAME (PGM003 ) TYPE (PGM) MBR (IMS1 ) CC ( 0) IMSID (IMS4 )
IMPTYPE (CHGLIST) </rsp>
<rsp>NAME (PGM004 ) TYPE (PGM) MBR (IMS1 ) CC ( 0) IMSID (IMS4 )
IMPTYPE (CHGLIST) </rsp>
<rsp>NAME (PGM005 ) TYPE (PGM) MBR (IMS1 ) CC ( 0) IMSID (IMS4 )
IMPTYPE (CHGLIST) </rsp>
<rsp>NAME (PGM006 ) TYPE (PGM) MBR (IMS1 ) CC ( 0) IMSID (IMS4 )
IMPTYPE (CHGLIST) </rsp>
<rsp>NAME (PGM002 ) TYPE (PGM) MBR (IMS1 ) CC ( 0) IMSID (IMS5 )
IMPTYPE (CHGLIST) </rsp>
<rsp>NAME (PGM003 ) TYPE (PGM) MBR (IMS1 ) CC ( 0) IMSID (IMS5 )
IMPTYPE (CHGLIST) </rsp>
<rsp>NAME (PGM004 ) TYPE (PGM) MBR (IMS1 ) CC ( 0) IMSID (IMS5 )
IMPTYPE (CHGLIST) </rsp>
<rsp>NAME (PGM005 ) TYPE (PGM) MBR (IMS1 ) CC ( 0) IMSID (IMS5 )
IMPTYPE (CHGLIST) </rsp>
<rsp>NAME (PGM006 ) TYPE (PGM) MBR (IMS1 ) CC ( 0) IMSID (IMS5 )
IMPTYPE (CHGLIST) </rsp>
</cmdrspdata>
<msgdata>
<mbr name="IMS1 ">
<msg>DFS3406I IMPORT COMMAND COMPLETE FOR ALL, REPOTYPE=IMSRSC,
  REPONAME=IMS_REPOS </msg>

```

```
</mbi>
</msgdata>
</imsout>
```

**Explanation:** IMS1 is active. IMS2, IMS3, IMS4, and IMS5 are not active. IMS1 through IMS5 have programs PGM002 through PGM006 defined in their resource lists. Because SCOPE(ALL) is specified, the change lists of the IMS systems that are down are updated with the resources that are being imported. The **IMPORT** command imports five programs, which are created for IMS1 and added to the change lists of IMS2, IMS3, IMS4, and IMS5. The IMSID column identifies the IMS whose change list was created or updated.

### Example 10 for IMPORT command

TSO SPOC input:

```
IMPORT DEFN SOURCE(REPO) NAME(DB0010) TYPE(DB) SCOPE(ALL) OPTION(ALLRSP)
```

TSO SPOC output:

| Name   | Type | MbrName | CC | CCText             | ImpType | IMSid |
|--------|------|---------|----|--------------------|---------|-------|
| DB0010 |      | IMS1    | 10 | NO RESOURCES FOUND |         |       |
| DB0010 | DB   | IMS1    | 0  |                    | CHGLIST | IMS5  |

When the **PF4** key is pressed, the following is displayed:

```
Log for . . . : IMPORT DEFN SOURCE(REPO) NAME(DB0010) TYPE(DB) SCOPE(ALL)
OPTION(ALLRSP)
```

```
IMSpIex . . . . . : PLEX1
Routing . . . . . :
Start time . . . . : 2013.189 16:18:35.27
Stop time . . . . . : 2013.189 16:18:35.33
Return code . . . . : 0200000C
Reason code . . . . : 00003008
Reason text . . . . : None of the clients were successful.
Command master . . : IMS1
```

| MbrName | Return Code | Reason Code | Reason text                     |
|---------|-------------|-------------|---------------------------------|
| IMS1    | 0000000C    | 00003000    | At least one request successful |

```
MbrName Messages
-----
IMS1 DFS3407E IMPORT COMMAND COMPLETE FOR SOME, REPOTYPE=IMSRSC,
REPONAME=IMS_REPOS
```

OM API input:

```
CMD(IMPORT DEFN SOURCE(REPO) NAME(DB0010) TYPE(DB) SCOPE(ALL) OPTION(ALLRSP))
```

OM API output:

```
<?xml version="1.0"?>
<!DOCTYPE imsout SYSTEM "imsout.dtd">
<imsout>
<ctl>
<omname>OM10M </omname>
<omvsn>1.6.0</omvsn>
<xmlvsn>20 </xmlvsn>
<statime>2013.189 23:18:35.272816</statime>
<stotime>2013.189 23:18:35.332778</stotime>
<staseq>CBA188C3C5270282</staseq>
<stoseq>CBA188C3D3CAA981</stoseq>
<rqsttkn1>USRT005 10161835</rqsttkn1>
<rc>0200000C</rc>
<rsn>00003008</rsn>
<rsnmsg>CSLN054I</rsnmsg>
<rsntxt>None of the clients were successful.</rsntxt>
</ctl>
<cmderr>
```

```

<mbr name="IMS1      ">
<typ>IMS      </typ>
<styp>DBDC    </styp>
<rc>0000000C</rc>
<rsn>00003000</rsn>
<rsntxt>At least one request successful</rsntxt>
</mbr>
</cmderr>
<cmd>
<master>IMS1      </master>
<userid>USRT005  </userid>
<verb>IMP </verb>
<kwd>DEFN          </kwd>
<input>IMPORT DEFN SOURCE(REPO) NAME(DB0010) TYPE(DB) SCOPE(ALL)
                OPTION(ALLRSP) </input>
</cmd>
<cmdrsphdr>
<hdr slbl="NAME" llbl="Name" scope="LCL" sort="a" key="2" scroll="no"
  len="8" dtype="CHAR" align="left" />
<hdr slbl="TYPE" llbl="Type" scope="LCL" sort="a" key="1" scroll="no"
  len="8" dtype="CHAR" align="left" skipb="yes" />
<hdr slbl="MBR" llbl="MbrName" scope="LCL" sort="a" key="3" scroll="no"
  len="8" dtype="CHAR" align="left" />
<hdr slbl="CC" llbl="CC" scope="LCL" sort="n" key="0" scroll="yes"
  len="4" dtype="INT" align="right" skipb="no" />
<hdr slbl="CCTXT" llbl="CCText" scope="LCL" sort="n" key="0"
  scroll="yes" len="32" dtype="CHAR" align="left" skipb="yes" />
<hdr slbl="ERRT" llbl="ErrorText" scope="LCL" sort="n" key="0"
  scroll="yes" len="*" dtype="CHAR" skipb="yes" align="left" />
<hdr slbl="IMPTYPE" llbl="ImpType" scope="LCL" sort="n" key="0"
  scroll="yes" len="8" dtype="CHAR" align="left" skipb="yes" />
<hdr slbl="IMSID" llbl="IMSid" scope="LCL" sort="n" key="0"
  scroll="yes" len="4" dtype="CHAR" align="left" skipb="yes" />
</cmdrsphdr>
<cmdrspdata>
<rsp>NAME(DB0010 ) TYPE(DB) MBR(IMS1 ) CC( 0) IMSID(IMS5 )
  IMPTYPE(CHGLIST) </rsp>
<rsp>NAME(DB0010 ) MBR(IMS1 ) CC( 10) CCTXT(NO RESOURCES FOUND)
</rsp>
</cmdrspdata>
<msgdata>
<mbr name="IMS1      ">
<msg>DFS3407E IMPORT COMMAND COMPLETE FOR SOME, REPOTYPE=IMSRSC,
  REPONAME=IMS_REPOS
</msg>
</mbr>
</msgdata>
</imsout>

```

**Explanation:** IMS1 is active, and IMS5 is down. The **IMPORT** command is routed to IMS1, which does not have database DB0010 in its resource list. The repository has database DB0010, which is defined for IMS5 but not IMS1. Because SCOPE(ALL) is specified, the change list of the IMS systems that are down are updated with the resources that are being imported. IMS1, the command master, reports that IMS5's change list is updated for DB0010, but it does not import anything itself. A response line with a completion code of X'10', no resources found, is returned for IMS1 because DB0010 is not defined for IMS1 in the repository.

### Related concepts

[How to interpret CSL request return and reason codes \(System Programming APIs\)](#)

[CSL RM, IMS, and Repository Server termination \(System Administration\)](#)

[IMSRSC repository administration \(System Administration\)](#)

[Change lists for the IMSRSC repository \(System Definition\)](#)

### Related reference

[“Command keywords and their synonyms” on page 59](#)

All IMS command keywords and their synonyms, as well as keywords supported by the OM API, are listed. The list covers command keywords for the OM command processing clients such as IMS, ODBM, IMSCON, and RM.



## Chapter 37. INITIATE commands

Use the **INITIATE** commands to initiate the online change process or online reorganization of the specified HALDB partitions.

INITIATE commands are:

- “[INITIATE OLC command](#)” on page 841
- “[INITIATE OLREORG command](#)” on page 878

### INITIATE OLC command

Use the **INITIATE OLC** command to initiate the global online change process. The resources that can be changed online are areas, databases, DMBs, Fast Path DEDB databases, MFS formats, programs, routing codes, and transactions. The correct online change command sequence is **INITIATE OLC PHASE(PREPARE)** followed by **INITIATE OLC PHASE(COMMIT)**.

#### Restrictions:

- The **INITIATE OLC** command is not supported if local online change is enabled.
- This command is invalid on XRF alternate and FDBR systems.
- **INIT OLC TYPE(MODBLKS)** does not apply or is not supported when dynamic resource definition (DRD) is enabled by MODBLKS=DYN in the <COMMON\_SERVICE\_LAYER> section of the DFSDFxxx PROCLIB member. To change MODBLKS resources in an online system when DRD is enabled, use the IMS type-2 commands **CREATE**, **UPDATE**, and **DELETE**.
- **INIT OLC TYPE(ACBLIB)** and **INIT OLC TYPE(ACBMBR)** do not apply or are not supported when the IMS management of ACBs is enabled by ACBMGMT=CATALOG in the <CATALOG> section of the DFSDFxxx PROCLIB member. To change ACBs in an online system when IMS manages ACBs, submit the changes by using either DDL or one of the IMS catalog population utilities and, if the changes are not activated automatically, issuing the **IMPORT DEFN SOURCE(CATALOG)**.

Subsections:

- “[Environment](#)” on page 841
- “[Syntax](#)” on page 842
- “[Keywords](#)” on page 842
- “[Usage notes](#)” on page 848
- “[Output fields](#)” on page 850
- “[Return, reason, and completion codes](#)” on page 852
- “[Examples](#)” on page 866

#### Environment

The following table lists the environments (DB/DC, DBCTL, and DCCTL) from which the **INITIATE** command and keywords can be issued.

Table 341. Valid environments for the INITIATE OLC command and keywords

| Command / Keywords  | DB/DC | DBCTL | DCCTL |
|---------------------|-------|-------|-------|
| <b>INITIATE OLC</b> | X     | X     | X     |
| OPTION              | X     | X     | X     |
| PHASE               | X     | X     | X     |

Table 341. Valid environments for the INITIATE OLC command and keywords (continued)

| Command / Keywords | DB/DC | DBCTL | DCCTL |
|--------------------|-------|-------|-------|
| TYPE               | X     | X     | X     |

## Syntax

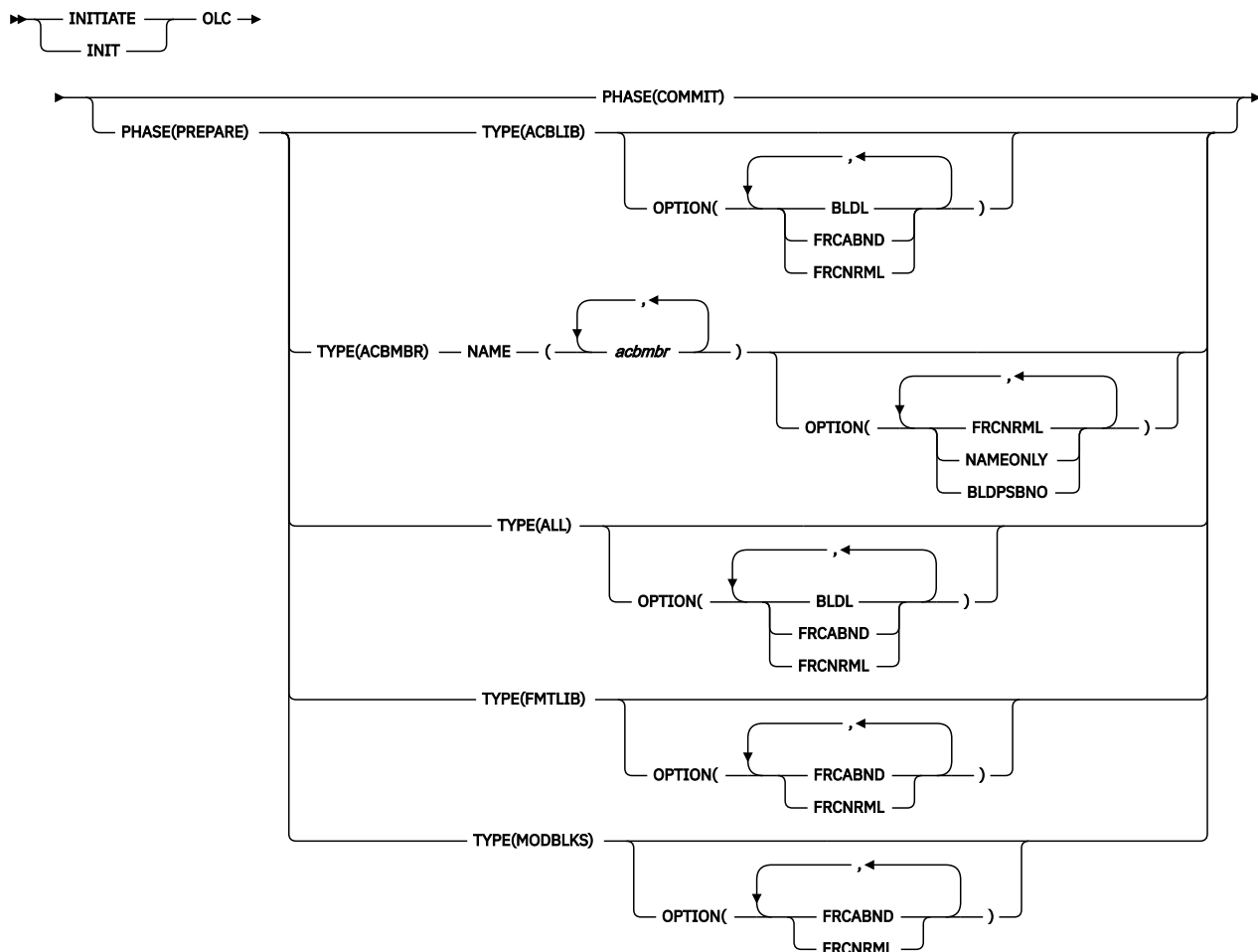

## Keywords

The following keywords are valid for the **INITIATE OLC** command:

### OPTION()

Specifies an additional function to be performed during an online change. Following is a list of additional functions:

#### BLDL

Sends asynchronous information message DFS3498I to the system console for each PSB or DMB not found in ACBLIB. This message does not affect the success of the command.

#### BLDPSBNO

Specifies only DBDs to be added without checking the reference list of associated PSBs.

By default, when a DBD is specified on the NAME keyword of the INITIATE OLC PHASE(PREPARE) TYPE(ACBMBR) command, the ACB member online change (OLC) function automatically copies all

associated PSBs and externally referenced DBDs from the staging ACB library to the active ACB library.

Depending on the number of PSBs and DBDs, the amount of time required for the copying process can be significant.

#### **FRCABND**

Forces the online change prepare phase even if one or more required IMS systems in the IMSplex have ended abnormally. An IMS is required to participate in the global online change if it is listed in the OLCSTAT data set as being current with the online change libraries. An IMS is listed in the OLCSTAT data set because it either participated in the last global online change or cold started since the last global online change. A successful global online change specified with the FRCABND removes an abnormally ended IMS from the list of required IMS systems in the OLCSTAT data set.

If the **INITIATE OLC PHASE(PREPARE)** command is specified with the FRCABND keyword and the command fails for any IMS, you can proceed with an **INITIATE OLC PHASE(COMMIT)** command, if you want, after canceling those IMS systems where prepare failed. Otherwise, you must cancel (abort) the online change and start over.

#### **FRCNRML**

Forces the online change prepare phase even if one or more required IMS systems in the IMSplex have terminated normally. An IMS is required to participate in the global online change if it is listed in the OLCSTAT data set as being current with the online change libraries. An IMS is listed in the OLCSTAT data set because it either participated in the last global online change or cold started since the last global online change. A successful global online change specified with the FRCNRML keyword removes an IMS that shut down normally from the list of required IMS systems in the OLCSTAT data set.

If the **INITIATE OLC PHASE(PREPARE)** command is specified with the FRCNRML keyword and the command fails for any IMS, you can proceed with an **INITIATE OLC PHASE(COMMIT)** command, if you want, after shutting down those IMS systems where prepare failed. Otherwise, you must terminate the online change and start over.

#### **NAMEONLY**

Specifies that only the DBDs and PSBs that are specified in the NAME keyword are to be processed.

By default, when a DBD is specified on the NAME keyword of the **INITIATE OLC PHASE(PREPARE) TYPE(ACBMBR)** command, the ACB member online change (OLC) function automatically copies all associated PSBs and externally referenced DBDs from the staging ACB library to active ACB library. Depending on the number of PSBs and DBDs, the amount of time required for the copying process can be significant.

In many cases, you can significantly reduce the amount of time the ACB member online change function takes by specifying **OPTION(NAMEONLY)** on the **INITIATE OLC PHASE(PREPARE) TYPE(ACBMBR)** command. The NAMEONLY option limits the processing of the ACB member online change function to only the DBDs and PSBs that are specified in NAME() keyword of the command.

If a PSB is specified in the NAME keyword, the following rules apply:

- Regardless of whether a PSB is new to the active ACB library or not, if the DBDs in the intent list have not been modified, this PSB is copied to the active ACB library.
- If a PSB is not new to the active ACB library and the DBDs in the intent list have been modified, this PSB is not copied to the active ACB library and a completion code 12B is returned.

If a DBD is specified in the NAME keyword, the following rules apply:

- If a DBD is new to the active ACB library and the DBDs in the reference list have not been modified, this DBD is copied to the active ACB library.
- If a DBD is new to the active ACB library and the DBDs in the reference list have been modified, this DBD is not copied to the active ACB library and a completion code 12C is returned.

- If a DBD is not new to the active ACB library and has been modified, this DBD is not copied to the active ACB library and a completion code 12A is returned.

### **NAME(*acbmbr*)**

Specifies that one or more ACB library members are to be copied from the staging ACB library to the active ACB library. *acbmbr* can be a DBD or a PSB that is being changed or added.

Wildcard characters are not supported in the member names.

The maximum number of DBDs and PSBs that can be specified on the *acbmbr* parameter is limited to 100.

If a DBD is being changed and **OPTION(NAMEONLY)** is not specified, you do not have to specify the associated PSBs on the command because all of the PSBs that are associated with the changed DBD are copied automatically from the staging ACB library to the active ACB library.

If a DBD that is being changed or added has external references and **OPTION(NAMEONLY)** is not specified, the secondary index DBD does not have to be specified on the *acbmbr* parameter. The **INIT OLC TYPE (ACBMBR)** command processing copies all externally referenced members of the DBD from the staging ACB library to the active ACB library.

### **PHASE()**

Specifies the online change phase to start. The **PREPARE** phase must be performed first, followed by the **COMMIT** phase.

#### **PREPARE**

Performs the online change prepare phase on each IMS system listed in the **OLCSTAT** data set by specifying which resources are to be added, changed, and deleted. **PREPARE** is not recovered across an emergency restart and must be reentered after restart if the **COMMIT** phase did not complete before IMS failure.

The prepare phase is rejected if any IMS systems in the IMSplex current with the online change libraries are down, unless the **FRCABND** or the **FRCNRML** option is used. The **OLCSTAT** data set lists the IMS systems that are current with the online change libraries. These IMS systems either participated in the last global online change or cold started after the last global online change. To force a global online change in spite of abended IMS systems, use the **FRCABND** option. To force a global online change in spite of IMS systems that are shut down normally, use the **FRCNRML** option. The prepare phase fails if any IMS participating in the global online change prepare phase fails, detects an error, or fails to respond in time. Zero, one, or more of the IMS systems remain in an online change prepare complete state. Issue the **QUERY MEMBER TYPE(IMS) SHOW(STATUS)** command to display the online change state of all the IMS systems in the IMSplex. Evaluate the **QUERY MEMBER TYPE(IMS)** output to help you decide whether to issue the **INITIATE OLC PHASE(PREPARE)** command to try the **PREPARE** phase again, or to issue the **TERMINATE OLC** command to terminate the online change. The IMS systems that are in an online change state remain in an online change state until you terminate or commit the online change. IMS does not automatically terminate online change because of a failure. IMS leaves the IMS systems in their online change states. You must issue the **QUERY MEMBER TYPE(IMS) SHOW(STATUS)** command and evaluate the output to decide whether to terminate the online change or attempt the online change phase again.

**Restriction:** The **INITIATE OLC PHASE(PREPARE)** command is rejected if the IMS to which the command is routed does not support global online change. If this situation occurs and there is an IMS that supports global online change, you must route the command to a specific IMS that supports global online change.

#### **COMMIT**

Performs the online change commit phase on each IMS listed in the **OLCSTAT** data set, which commits the online changes by bringing all the newly defined resources online, updating changed resources, and removing deleted resources. The commit phase consists of commit phase 1, the **OLCSTAT** data set update, commit phase 2, and commit phase 3. The **OLCSTAT** data set is updated with the new current online change libraries and the list of IMS systems that are current with the current online change libraries. The commit phase 2 switches the online environment from



the active ACBLIB, FORMAT, or MODBLKS libraries to the inactive libraries containing the new or changed resource descriptions.

**Recommendation:** Use the **/DISPLAY MODIFY** command to display the work in progress for resources to be changed or deleted, before attempting the COMMIT phase.

When COMMIT is successful, the modifications persist across all IMS restarts, unless global online change occurs while this IMS is down.

The commit phase fails if any IMS participating in the global online change commit phase fails, detects an error, or fails to respond in time. Zero, one, or more of the IMS systems might be in an online change prepare complete state, a commit phase 1 complete state, or no longer in an online change state because commit phase 2 succeeded. Issue the **QUERY MEMBER TYPE(IMS) SHOW(STATUS)** command to display the online change state of all the IMS systems in the IMSplex. Evaluate the **QUERY MEMBER TYPE(IMS)** output to help you decide whether to issue the **INITIATE OLC PHASE(COMMIT)** command to try the commit again, or issue the **TERMINATE OLC** command to terminate the online change. The IMS systems that are in an online change state remain in an online change state until you terminate or commit the online change.

IMS does not automatically terminate online change because of a failure. IMS leaves the IMS systems in their online change states. You must issue the **QUERY MEMBER TYPE(IMS) SHOW(STATUS)** command and evaluate the output to decide whether to terminate the online change or attempt the online change phase again.

If a database is deleted, IMS closes the database and makes it unavailable to programs. Also, if the database is authorized for DBRC, COMMIT deauthorizes it.

If FMTLIB is being changed, most new and in-progress requests are queued for processing after the **INITIATE OLC PHASE(COMMIT)** command is completed.

Most new and in-progress requests are queued for processing.

An **INITIATE OLC PHASE(COMMIT)** command is rejected if:

- An **INITIATE OLC PHASE(PREPARE)** command was not previously entered.
- Commit phase 1 fails on one or more IMS systems in the IMSplex.
- Transactions to be deleted have messages queued.
- Transactions to be changed by the following system definition keywords have messages queued:
  - MSGTYPE
  - INQUIRY
  - FPATH
  - EDIT
  - SPA
  - SERIAL
- Transactions to be changed by keywords not shown in the previous bullet have messages queued and the transactions have not been the object of a **/STOP** or **/PSTOP** command.
- Transactions with access to programs or databases to be changed or deleted are prevented from updating and the transactions have not been the object of a **/STOP** or **/PSTOP** command. When a transaction shows a status of USTOP during a **/DISPLAY TRAN** command, the **/STOP** command might have to be entered because the **/PSTOP** command might not enable the **INITIATE OLC** command to complete the transaction.
- Any program (PSB) that is currently scheduled has a program, database, or transaction change or deletion. This includes Wait for Input (WFI) and Fast Path transactions. All WFI and Fast Path regions that reference changed or deleted routing codes, programs, or databases must be stopped before entering the **INITIATE OLC PHASE(COMMIT)**.
- An I/O error occurs while reading the inactive MFS FORMAT library directory or the resident index (\$\$IMSDIR) member.

- A **/START DATABASE** command is in progress for any database that is changed or deleted.
- A **/DBDUMP** or **/DBRECOVERY** command is in progress for any database that is changed or deleted.
- An IMS that participated in the prepare phase was shut down normally or ended abnormally. The online change must be aborted and started over.
- OM routed the command to an IMS where local online change is enabled.
- The OLCSTAT data set is not locked for global online change.

The **INITIATE OLC PHASE(PREPARE)** command locks the OLCSTAT data set, so that no IMS systems can initialize during the global online change. The commit command is rejected if the lock is not set. The **INITIATE OLC PHASE(PREPARE)** command might not have completed successfully or the OLCSTAT data set contents might be invalid.

- An IFP region is running. The **INITIATE OLC PHASE(COMMIT)** command is rejected because an active route code exists. All IFP regions must be terminated before issuing a COMMIT.

IMS does not reject the **INITIATE OLC PHASE(COMMIT)** command if the online change indirectly affects transactions (having work in progress) that reference resources in the ACB library or in the MODBLKS data set that are directly affected by the online change. These transactions themselves are not being changed (no attribute on the TRANSACT macro is being changed), but they reference a PDIR, PSB, or DMB that is affected by the online change. A transaction can be indirectly affected by an online change in one of the following situations:

- The transaction references a PSB directory (PDIR) control block in the IMS.MODBLKS data set that is being changed.
- The transaction references a PSB in the ACB library that is being changed.
- The transaction references a PSB directory (PDIR) control block in the IMS.MODBLKS data set which in turn references a database that is being changed online.
- The transaction references a PSB in the ACB library (IMS.ACBLIB) that references a database that is being changed online.

Operator action might be required to prevent the preceding conditions. For example, if a program or database is scheduled, the operator must either wait until the program or database is finished before the **INITIATE OLC PHASE(COMMIT)** command is entered or issue the **/STOP, /PSTOP, or UPDATE TRAN** command for the associated transaction.

If IMS is in an IMSplex and Resource Manager (RM) is using a resource structure, the transactions being added by the online change are registered to RM if they are not already registered to RM. If any error occurs during the CSLRMUPD request to register the transactions, the **/MODIFY** or **INITIATE OLC** command fails and IMS will be in a COMMIT2F state.

If an **INITIATE OLC PHASE(COMMIT)** command results in the IMS remaining in a COMMIT2F state, a completion code of the error that caused it is returned to OM. If the error can be fixed, the **INITIATE OLC PHASE(COMMIT)** can be reissued and CSLRMUPD tried again and the online change completed. If the error cannot be fixed, the IMS must be canceled and warm started as the online change is not complete.

## TYPE()

Specifies the types of resources that are changed online. The resources are as follows:

### ACBLIB

Causes IMS to prepare to add, change, or delete database descriptors (DMB) and program descriptors (PSB) to ACBLIB. The online environment is switched from the active ACBLIB to the inactive ACBLIB containing new or changed DMB and PSBs. ACBLIB members that are not found are displayed as CHANGED because a DDIR or PDIR exists in MODBLKS. Additions or deletions to ACBLIB require the MODBLKS parameter. Quiesces transactions to be changed or deleted and transactions that access databases or programs to be changed or deleted. Fast Path DEDBs are supported but Fast Path MSDBs are not supported.

ACBLIB is disabled if IMS management of ACBs is enabled for IMS. If IMS management of ACBs is enabled on all of the IMS systems, the **INITIATE OLC TYPE(ACBLIB)** command fails. If IMS management of ACBs is enabled on some of the IMS systems, the **INITIATE OLC PHASE(PREPARE) TYPE(ACBLIB)** command succeeds with a warning return code indicating that the command was not applicable to some IMS systems. The IMS systems where online change for ACBLIB is enabled, perform the ACBLIB online change. The IMS systems where IMS management of ACBs is enabled, return a completion code of 1 (not applicable).

If the **INITIATE OLC PHASE(PREPARE)** command is specified, with type **ACBLIB** and **MODBLKS** and/or **FMTLIB**, the OLC is performed as follows:

- IMS systems where ACBLIB online change is enabled, perform the ACBLIB OLC.
- IMS systems where IMS management of ACBs is enabled, ignore the ACBLIB keyword.
- IMS systems where MODBLKS online change is enabled, perform the MODBLKS OLC.
- IMS systems where DRD is enabled, ignore the MODBLKS keyword.
- IMS systems where FMTLIB is enabled, perform FMTLIB OLC.
- DBCTL systems ignore the FMTLIB keyword. DBCTL IMS systems with DRD and IMS management of ACBs enabled ignore the MODBLKS, FMTLIB and ACBLIB keywords and no OLC is performed.

### **ACBMBR**

Specifies that an ACB library member online change process is to be performed for the specified ACB library member name or names. The command response lists all the members that are to be copied from the staging ACB library to the active ACB library during the COMMIT command processing.

When you issue either an **INIT OLC PHASE(PREPARE) TYPE(ALL)** command or an **INIT OLC PHASE(PREPARE) TYPE(ACBLIB)** command, IMS initiates a full online change process for either the ACB library or the ACB, FMT, and MODBLKS libraries. In either case, an ACB library member online change process is not involved.

After an **INITIATE OLC PHASE(COMMIT)** command, when the TYPE(ACBMBR) online change completes successfully, the active and inactive ACB library suffixes and the MODID are not updated in the OLCSTAT data set or in the IMS control blocks because ACB library member online change processing changes or adds ACB members directly into the active ACB library.

ACBMBR OLC is disabled if IMS management of ACBs is enabled for IMS. If IMS management of ACBs is enabled on all the IMS systems, the **INITIATE OLC TYPE(ACBMBR)** command fails. If IMS management of ACBs is enabled on some IMS systems, the **INITIATE OLC PHASE(PREPARE) TYPE(ACBMBR)** command succeeds with a warning return code indicating that the command was not applicable to some IMS systems. The IMS systems where online change for ACBLIB is enabled, perform the ACBMBR online change. The IMS systems where IMS management of ACBs is enabled return a completion code of 1 (not applicable).

### **ALL**

Prepares to add, change, and delete resources for the ACBLIB, FMTLIB, or MODBLKS libraries. The BLDL function is performed for ACBLIB. ALL does not include the ACBMBR online change.

If the **INITIATE OLC PHASE(PREPARE)** command is specified with **ALL**, the OLC is performed as follows:

- IMS systems where ACBLIB online change is enabled, perform the ACBLIB OLC.
- IMS systems where IMS management of ACBs is enabled, ignore the ACBLIB keyword.
- IMS systems where MODBLKS online change is enabled, perform the MODBLKS OLC.
- IMS systems where DRD is enabled, ignore the MODBLKS keyword.
- IMS systems where FMTLIB is enabled, perform FMTLIB OLC.
- DBCTL systems ignore the FMTLIB keyword. DBCTL IMS systems with DRD and IMS management of ACBs enabled ignore the MODBLKS, FMTLIB and ACBLIB keywords and no OLC is performed.

## FMTLIB

Causes IMS to prepare to add, change, or delete MFS maps in the FMTLIB library that are produced by the MFS Language utility and Service utility. The online environment is switched from the active FMTLIB to the inactive FMTLIB containing new MFS maps produced by the MFS Language utility and Service utility. The FMTLIB parameter is ignored with DBCTL. There are no restrictions on the use of MFS format blocks until the **INITIATE OLC PHASE(COMMIT)** command is entered.

If the **INITIATE OLC PHASE(PREPARE)** command is specified with type **FMTLIB** and **MODBLKS** and/or **ACBLIB**, the OLC is performed as follows:

- IMS systems where ACBLIB online change is enabled, perform the ACBLIB OLC.
- IMS systems where IMS management of ACBs is enabled, ignore the ACBLIB keyword.
- IMS systems where MODBLKS online change is enabled, perform the MODBLKS OLC.
- IMS systems where DRD is enabled, ignore the MODBLKS keyword.
- IMS systems where FMTLIB is enabled, perform FMTLIB OLC.
- DBCTL systems ignore the FMTLIB keyword. DBCTL IMS systems with DRD and IMS management of ACBs enabled ignore the MODBLKS, FMTLIB and ACBLIB keywords and no OLC is performed.

## MODBLKS

Causes IMS to prepare to add, change, or delete database, transaction, program, or RTCODE resources in the MODBLKS library.

The online environment is switched from the active MODBLKS library to the inactive MODBLKS library. The MODBLKS library contains a subset of control blocks produced by IMS system definition. Transactions to be changed or deleted and transactions that access databases or programs to be changed or deleted are quiesced.

MODBLKS is disabled if DRD is enabled for IMS. If DRD is enabled on all the IMS systems, the **INITIATE OLC TYPE(MODBLKS)** command fails. If DRD is enabled on some IMS systems, the **INITIATE OLC PHASE(PREPARE) TYPE(MODBLKS)** command succeeds with a warning return code indicating that the command was not applicable to some IMS systems. The IMS systems where online change for MODBLKS is enabled perform the MODBLKS online change. The IMS systems where DRD is enabled return a completion code of 1 (not applicable).

If the **INITIATE OLC PHASE(PREPARE)** command is specified, with type **MODBLKS** and **FMTLIB** and/or **ACBLIB**, the OLC is performed as follows:

- IMS systems where ACBLIB online change is enabled perform the ACBLIB OLC.
- IMS systems where IMS management of ACBs is enabled ignore the ACBLIB keyword.
- IMS systems where MODBLKS online change is enabled perform the MODBLKS OLC.
- IMS systems where DRD is enabled ignore the MODBLKS keyword.
- IMS systems where FMTLIB is enabled perform FMTLIB OLC.
- DBCTL systems ignore the FMTLIB keyword. DBCTL IMS systems with DRD and IMS management of ACBs enabled ignore the MODBLKS, FMTLIB and ACBLIB keywords and no OLC is performed.

## Usage notes

The **INITIATE OLC** command can be issued to an IMSplex by using the Batch SPOC utility.

If an IMSplex is running with a Resource Manager (RM) environment (RMENV=Y in the DFSCGxxx PROCLIB member), the **INITIATE OLC** command initiates a phase of global online change of resources and coordinates the phase with all of the IMS systems in the IMSplex. The **INITIATE OLC** command is similar to the command sequence **/MODIFY PREPARE** and **/MODIFY COMMIT**, except that it applies to an IMSplex-wide global online change. OM sends the **INITIATE OLC** command to one master IMS

in the IMSplex. The command master IMS uses RM services to coordinate the online change with all participating IMS systems.

If the command master IMS in an IMSplex is running without an RM environment (RMENV=N in the DFSCGxxx PROCLIB member), the **INITIATE OLC** command is performed locally at the IMS to which the command was sent. The OLCSTAT data set must be unique for each IMS in the IMSplex that is running without an RM environment. The OLCSTAT data set cannot be shared between IMS systems and must be unique. If the OLCSTAT data set contains the name of an IMS other than the one processing the online change, the **INITIATE OLC** command is rejected. You can use the **QUERY OLC** command to display the contents of the OLCSTAT data set to determine which IMS member name is invalid. To correct the data set, you can use the Global Online Change utility, DFSUOLC0.

If the **INITIATE OLC** command is issued with a route list containing either the default Route All or multiple IMS systems that do not have RM running, the **INITIATE OLC** command must be issued separately to each IMS. To perform online change for IMS systems that do not have RM running, you must issue the **INITIATE OLC** command to each IMS. To determine which IMS systems are defined with RMENV=N in the DFSCGxxx PROCLIB member, you can issue the **QUERY MEMBER SHOW(ATTRIB)** command.

If some IMS systems in an IMSplex use RM services and some do not, you must ensure that the OLCSTAT data sets are properly defined to the IMS systems. The IMS systems that use RM services and global online change must share one OLCSTAT data set. Each IMS system that does not use RM services must have its own unique OLCSTAT data set.

When all of the IMS systems return the completion code of 1 (CMD NOT APPLICABLE), the online change cannot be committed as there is nothing to commit. You must issue a **TERM OLC** to terminate the OLC phase in progress. IMS systems remain in OLCPREPC state until the OLC is terminated.

If the **INITIATE OLC PHASE(PREPARE)** command is specified without an FRCABND or FRCNRML keyword and the command fails because one or more IMS systems are down or go down before the online change is committed, the online change must be aborted and started over. Issue the **TERMINATE OLC** command to terminate the online change.

The **INITIATE OLC** command master usually performs the online change phase locally first. If the online change phase fails locally, the command master usually skips sending the online change phase to the other IMS systems, sets a completion code for each other IMS indicating that the online change phase was not attempted, and terminates command processing. However, if the **INITIATE OLC PHASE(COMMIT)** command fails on the local IMS because of work in progress for resources that are directly affected by the online change, the command master still sends the commit phase 1 to the other IMS systems. The purpose is to report work in progress for all the IMS systems in the IMSplex, to facilitate completion of the work in progress.

In a mixed IMSplex, you might have some variations of IMS systems that support a particular type of online change and some that do not. At least one IMS in the IMSplex must successfully perform the online change phase for the command to be considered successful. If no IMS in the IMSplex supports the type of online change that the command is attempting, the command reason code indicates that none of the IMS systems performed the online change phase. If you enter an **INITIATE OLC PHASE(PREPARE)** command that does not apply to any IMS in the IMSplex, you must terminate the online change with a **TERMINATE OLC** command.

If the **INITIATE OLC PHASE(COMMIT)** command fails for any IMS before the OLCSTAT data set is updated, either correct the errors and try the commit again or terminate the online change with a **TERMINATE OLC** command. If the **INITIATE OLC PHASE(COMMIT)** command fails for any IMS after the OLCSTAT data set has been updated, correct the errors and try the commit again. The online change cannot be terminated.

If an IMS ends abnormally during online change and the **INITIATE OLC PHASE(PREPARE)** command was not specified with FRCABND, then issue the **TERMINATE OLC** command to terminate the online change. The **INITIATE OLC PHASE(COMMIT)** command is not permitted in this case. If an IMS ends abnormally during online change and the **INITIATE OLC PHASE(PREPARE)** command was specified with FRCABND, then the **INITIATE OLC PHASE(COMMIT)** command is permitted.

Type-1 and type-2 commands that come from the OM interface are rejected during the commit phase, if the command changes resources. Commands that change resources could interfere with the online change of the resources. Type-1 and type-2 commands that come from the OM interface are permitted during the commit phase, if the command displays resources such as **QUERY** or **/DISPLAY**. Type-1 commands that are entered from the system console or an IMS terminal are queued during the online change commit phase. These commands run after the online change is committed or aborted.

Each IMS participating in the global online change does not issue the same synchronous online change messages to the master terminal or system console that it does for a local online change. The OM command response contains information equivalent to the online change messages that appear for the local online change, such as the DFS3499 message contents.

Each IMS participating in the global online change might issue asynchronous online change messages to the system console, such as DFS3400, DFS3445, and DFS3498.

The **INITIATE OLC PHASE(PREPARE) TYPE(ALL)** command ignores the following resource definitions on IMS systems where dynamic resource definition is enabled: database directories (DDIRs), program directories (PDIRs), Fast Path routing codes (RCTEs), and scheduler message blocks (SMBs, which are also known as transactions). **INITIATE OLC PHASE(PREPARE)** specified with **TYPE MODBLKS** alone or with other keywords is rejected on the IMS systems where dynamic resource definition is enabled, but processed on the IMS systems where dynamic resource definition is not enabled. The **INITIATE OLC PHASE(COMMIT)** command master updates the OLCSTAT data set to switch the MODBLKS data set, even in the case where the master has dynamic resource definition enabled and the MODBLKS online change does not apply. The MODBLKS data set is switched in the OLCSTAT data set in case another IMS in the IMSplex does not have dynamic resource definition enabled. If the **INITIATE OLC PHASE(PREPARE)** command is specified with **TYPE MODBLKS** and there is only one IMS in the IMSplex and it has dynamic resource definition enabled, the command is rejected and the OLCSTAT data set is not updated.

The OM command timeout default of 300 seconds (5 minutes) might not be enough time for the online change phase to complete. You might have to specify a timeout value on the command based on the needs of the installation. To change the timeout value, use the **TIMEOUT** parameter of the **CSLQMCM** command request or specify a **Wait (timeout)** value when you issue the **INITIATE OLC** command from **TSO SPOC**.

An online change of a PSB or DBD removes the member from the 31-bit pool as well as from the 64-bit pool.

If a resident program is changed, it becomes nonresident locally because its definition in the resident PSB pool is no longer valid. If its resident definition attribute was not changed, it becomes resident again at the next IMS restart. If a nonresident program is changed to be resident, the residency takes effect at the next IMS restart.

## Output fields

The following table shows the output fields for an **INITIATE OLC** command. The columns in the table are as follows:

### Short label

Contains the short label generated in the XML output.

### Keyword

Identifies the keyword on the command that caused the field to be generated. N/A appears for output fields that are always returned.

### Meaning

Provides a brief description of the output field.

Table 342. INITIATE OLC output field descriptions

| Short label | Keyword                         | Meaning  |
|-------------|---------------------------------|--|
| ACBL        | TYPE(ACBLIN,FMTLIB,MODBLKS,ALL) | The current ACBLIB library suffix (if prepare succeeded or commit succeeded that did not include ACBLIB), or the new ACBLIB library suffix (if commit succeeded for ACBLIB). The ACBLIB suffix is returned if the online change prepare phase or commit phase is successful. Suffix A means that ACBLIBA is current. Suffix B means that ACBLIBB is current. |
| ACBS        | TYPE(ACBMBR)                    | Value of an IMS system.  |
| ADD         | TYPE(ACBMBR)                    | Resource added. The ACB member is found in the staging ACBLIB and not in the active ACBLIB. The ACB member is to be added to the active ACBLIB.  |
| CC          | N/A                             | Completion code returned by IMS member that performed the global online change phase. Completion code is always returned.  |
| CCTXT       | <i>error</i>                    | Completion code text that briefly explains the meaning of the nonzero completion code.   |
| CHG         | TYPE(ACBMBR)                    | Resource changed. The ACB member is found in the staging ACBLIB and the active ACBLIB. The ACB member is to be changed in the active ACBLIB.   |
| CPY         | TYPE(ACBMBR)                    | Resource copied. The ACB member is found in the staging ACBLIB and not in the active ACBLIB. The ACB member does not have a PDIR for a PSB or a DDIR for a DBD in an IMS system. The ACB member is to be copied from the staging to the active ACBLIB. The ACB resource is not available until a PDIR for a PSB or a DDIR for a DBD is created.              |
| DBD         | TYPE(ACBMBR)                    | DBD resource name  |
| ERRT        | N/A                             | Error text returned by IMS member that failed performing the global online change phase. Error text might be returned if the completion code is nonzero.   |
| FMTL        | TYPE(ACBLIN,FMTLIB,MODBLKS,ALL) | The current FMTLIB library suffix (if prepare succeeded or commit succeeded that did not include FMTLIB), or the new FMTLIB library suffix (if commit succeeded for FMTLIB). The FMTLIB suffix is returned if the online change prepare phase or commit phase is successful. Suffix A means that FMTLIBA is current. Suffix B means that FMTLIBB is current. |
| IMSMBR      | N/A                             | IMS member that performed the global online change phase. The IMS member name is always returned.  |
| MBR         | N/A                             | IMSplex member that built the line of output. IMS identifier of the IMS that is the master of this online change phase. IMS identifier is always returned.   |

Table 342. INITIATE OLC output field descriptions (continued)

| Short label | Keyword                         | Meaning  |
|-------------|---------------------------------|--|
| MODB        | TYPE(ACBLIN,FMTLIB,MODBLKS,ALL) | The current MODBLKS library suffix (if prepare succeeded or commit succeeded that did not include MODBLKS), or the new MODBLKS library suffix (if commit succeeded for MODBLKS). The MODBLKS suffix is returned if the online change prepare phase or commit phase is successful.<br><br>Suffix A means that MODBLKSA is current. Suffix B means that MODBLKSB is current. |
| MODI        | TYPE(ACBLIN,FMTLIB,MODBLKS,ALL) | The current modify ID (if prepare succeeded), or new modify ID (if commit succeeded). The modify ID - 1 indicates the number of global online changes that have been performed. The modify ID is returned if the online change prepare phase or commit phase is successful.  |
| PSB         | TYPE(ACBMBR)                    | PSB resource name  |
| RSC         | TYPE(ACBSHR)                    | Resource type is not known.  |
| RFS         | TYPE(ACBSHR)                    | Resource is refreshed in the active ACBLIB.  |

## Return, reason, and completion codes

Two sets of return and reason codes are returned when a command is issued through the OM API. One set of codes is for the OM request and the other set of codes is for the command itself. The OM request return and reason codes that can be returned as a result of the **INITIATE OLC** command are standard for all commands entered through the OM API.

The return and reason codes returned by the **INITIATE OLC** command are passed from the OM API on to the SPOC application. These codes are encapsulated in XML tags similar to how the response to the command is encapsulated in XML tags. The IBM-supplied TSO SPOC displays these codes, whereas a user-written SPOC application might choose not to display these codes.

Some reason codes are accompanied by a complete list of IMS systems and return codes. The reason code meaning indicates whether a list is returned. A partial list of IMS systems and return codes might be returned with any **INITIATE OLC** error reason code, if any output was built before the error was detected.

The following table includes the return and reason codes and a brief explanation of the codes. The return or reason code returned for the command might also indicate an error from a CSL request.



Table 343. Return and reason codes for INITIATE OLC

| Return code | Reason code | Meaning   |
|-------------|-------------|---|
| X'00000000' | X'00000000' | <p>The <b>INITIATE OLC</b> command completed successfully. The <b>INITIATE OLC</b> command applies to all of the IMS systems listed in the OLCSTAT data set. Each IMS listed in the OLCSTAT data set is current with the online change libraries and required to participate in the online change. The FRCABND option was not specified. The FRCNRML option was not specified, either.</p> <p>If the <b>INITIATE OLC PHASE(PREPARE)</b> command was specified, all of the IMS systems listed in the OLCSTAT data set are now in an online change prepare state.</p> <p>If the <b>INITIATE OLC PHASE(COMMIT)</b> command was specified, all of the IMS systems listed in the OLCSTAT data set successfully committed the online change.</p> <p>An output line is built for each IMS listed in the OLCSTAT data set. Each output line contains the IMS member name and a completion code of zero.</p>   |
| X'00000004' | X'0000100C' | <p>The command completed successfully, but was not applicable to one or more IMS systems for acceptable reasons. The <b>INITIATE OLC</b> command applies to all of the IMS systems listed in the OLCSTAT data set. Each IMS listed in the OLCSTAT data set is current with the online change libraries and required to participate in the online change (unless FRCABND or FRCNRML is specified).</p> <p>An output line is built for each IMS listed in the OLCSTAT data set. Each output line contains the IMS member name and a completion code. A nonzero completion code might be accompanied by error text. One or more of the IMS systems contain a completion code indicating that the online change phase did not apply to this IMS, such as the IMS state is shutdown and FRCSHUT was specified, the IMS state is abended and FRCABND was specified, the online change type does not apply to this IMS, or this IMS is already in the correct online change state. The <b>INITIATE OLC</b> completion code table contains the list of completion codes and error text that can be returned by the <b>INITIATE OLC</b> command.</p> |
| X'00000004' | X'0000100D' | <p>The specified online change type is not applicable to all the IMS systems in the OLCSTAT. Because the online change cannot be committed, use the <b>TERMINATE OLC</b> command to terminate the online change in progress. This error return and reason code combination is returned in the following situations:</p> <ul style="list-style-type: none"> <li>• If a MODBLKS type of online change process is attempted in an IMSplex where all IMS systems are DRD enabled</li> <li>• If an FMTLIB type of online change process is attempted in an IMSplex where all IMS systems are configured as DBCTL systems</li> </ul>  |
| X'00000008' | X'00002040' | <p>The <b>INITIATE OLC</b> command is rejected because of an invalid filter. The <b>INITIATE OLC PHASE(PREPARE) OPTION(BLDL)</b> command can be specified only with TYPE(ACBLIB) or TYPE(ALL). The <b>INITIATE OLC PHASE(COMMIT)</b> command does not support TYPE or OPTION.</p>   |
| X'00000008' | X'00004300' | <p>The command is not allowed, because online change for the MODBLKS data set is disabled (DFSDFxxx or DFSCGxxx is defined with MODBLKS=DYN). Dynamic resource definition is enabled.</p>   |

Table 343. Return and reason codes for INITIATE OLC (continued)

| Return code | Reason code | Meaning  |
|-------------|-------------|--|
| X'0000000C' | X'00003000' | <p>The <b>INITIATE OLC</b> command is successful for at least one IMS but not all IMS systems. The <b>INITIATE OLC</b> command applies to all of the IMS systems listed in the OLCSTAT data set. Each IMS listed in the OLCSTAT data set is current with the online change libraries and required to participate in the online change (unless FRCABND or FRCNRML is specified).</p> <p>An output line is built for each IMS listed in the OLCSTAT data set. Each output line contains the IMS member name and a completion code. A nonzero completion code might be accompanied by error text. One or more of the IMS systems returned an error completion code. The <b>INITIATE OLC</b> completion code table contains the list of completion codes and error text that can be returned by the <b>INITIATE OLC</b> command.</p> <p><b>If INITIATE OLC PHASE(PREPARE)</b> fails, the online change must be aborted and started over.</p> <p><b>If INITIATE OLC PHASE(COMMIT)</b> fails and you want to try the commit again, correct the problem, and issue the <b>INITIATE OLC PHASE(COMMIT)</b> command again.</p> <p>To abort the online change, issue the <b>TERMINATE OLC</b> command. If the <b>INITIATE OLC PHASE(PREPARE)</b> command failed or the <b>INITIATE OLC PHASE(COMMIT)</b> command failed before the commit master updated the OLCSTAT data set, the online change is aborted. See 'INITIATE OLC error handling' for more details.</p>  |
| X'0000000C' | X'00003004' | <p>The <b>INITIATE OLC</b> command failed for all of the IMS systems. The <b>INITIATE OLC</b> command applies to all of the IMS systems listed in the OLCSTAT data set. Each IMS listed in the OLCSTAT data set is current with the online change libraries and required to participate in the online change (unless FRCABND or FRCNRML is specified).</p> <p>An output line is built for each IMS listed in the OLCSTAT data set. Each output line contains the IMS member name and a completion code. A nonzero completion code might be accompanied by error text. The <b>INITIATE OLC</b> completion code table contains the list of completion codes and error text that can be returned by the <b>INITIATE OLC</b> command.</p> <p>If <b>INITIATE OLC PHASE(PREPARE)</b> fails for all of the IMS systems listed in the OLCSTAT data set, no IMS is in an online change state. You can try the online change again with another <b>INITIATE OLC PHASE(PREPARE)</b> command.</p> <p>If <b>INITIATE OLC PHASE(COMMIT)</b> fails and you want to try the commit again, correct the problem, and then issue the <b>INITIATE OLC PHASE(COMMIT)</b> command again.</p> <p>To terminate the online change, issue the <b>TERMINATE OLC</b> command. If the <b>INITIATE OLC PHASE(PREPARE)</b> command failed or the <b>INITIATE OLC PHASE(COMMIT)</b> command failed before the commit master updated the OLCSTAT data set, the online change is terminated.</p> <p>For more details, see “INITIATE OLC error handling” on page 875.</p> |

Table 343. Return and reason codes for INITIATE OLC (continued)

| Return code | Reason code | Meaning   |
|-------------|-------------|---|
| X'00000010' | X'00004004' | The <b>INITIATE OLC</b> command failed because there is no CQS. RM attempted to access the process resource on the resource structure, but it failed because CQS is not available. The online change phase might have succeeded on one or more IMS systems.<br><br>For more details, see <a href="#">“INITIATE OLC error handling” on page 875.</a>   |
| X'00000010' | X'0000400C' | The <b>INITIATE OLC</b> command failed because it is invalid for an XRF alternate.  |
| X'00000010' | X'0000401C' | The <b>INITIATE OLC</b> command failed because it is invalid for an FDBR region.  |
| X'00000010' | X'00004018' | The <b>INITIATE OLC</b> command failed because the RM resource structure is not available. The online change phase might have succeeded on one or more IMS systems.<br><br>For more details, see <a href="#">“INITIATE OLC error handling” on page 875.</a>   |
| X'00000010' | X'00004100' | The <b>INITIATE OLC PHASE(PREPARE)</b> command is rejected because the resource structure is full. RM failed trying to create the process resource on the resource structure.   |
| X'00000010' | X'00004104' | The <b>INITIATE OLC</b> command failed because RM is not available. The online change phase might have succeeded on one or more IMS systems. Either there is no RM address space, or RM is active but not registered to SCI because CQS or the resource structure is not available.<br><br>For more details, see <a href="#">“INITIATE OLC error handling” on page 875.</a>                             |
| X'00000010' | X'00004108' | The <b>INITIATE OLC</b> command failed because SCI is not available. The online change phase might have succeeded on one or more IMS systems.<br><br>For more details, see <a href="#">“INITIATE OLC error handling” on page 875.</a>   |
| X'00000010' | X'0000410C' | The <b>INITIATE OLC</b> command is rejected, because global online change is not enabled. Local online change is enabled. Use the <b>/MODIFY</b> command for local online change. If your IMSplex is made up of some IMS systems that support global online change and some that support local online change, route the <b>INITIATE OLC</b> command to an IMS that is enabled for global online change. |
| X'00000010' | X'0000410D' | Online change prepare has already been done. Another prepare command is not allowed. The only commands that are allowed when IMS is in this state are <b>INITIATE OLC PHASE(COMMIT)</b> or <b>TERMINATE OLC</b> .   |
| X'00000010' | X'0000410E' | Online change prepare has not been done. An online change prepare command must complete successfully before a commit command is attempted.  |

Table 343. Return and reason codes for INITIATE OLC (continued)

| Return code | Reason code | Meaning   |
|-------------|-------------|---|
| X'00000010' | X'0000410F' | The online change has already been committed, so it cannot be terminated. However, an error occurred that prevented the commitment from being fully completed. For example, one of the IMS systems that participates in the online change was unable to complete commit phase 2 or commit phase 3, or an IMS response to RM timed out and the commit master could not determine whether the online change commit succeeded on the other IMS systems. Another commit command is required to complete the online change commitment.   |
| X'00000010' | X'00004110' | The <b>INITIATE OLC</b> command is rejected, because the command does not apply to the online change state of the command master.<br><br><b>INITIATE OLC PHASE(COMMIT)</b> is rejected if the command master is not in an online change prepare state.<br><br><b>INITIATE OLC PHASE(COMMIT)</b> is rejected if routed to an IMS that already successfully completed commit phase 3.<br><br><b>INITIATE OLC PHASE(PREPARE)</b> is rejected if the command master is already in an online change prepare state.<br><br>For more details, see <a href="#">“INITIATE OLC error handling” on page 875.</a> |
| X'00000010' | X'00004111' | The <b>INITIATE OLC</b> command failed because the command master is not in the OLCSTAT data set.   |
| X'00000010' | X'00004112' | The <b>PREPARE</b> command cannot be processed, because the OLCSTAT is locked.  |
| X'00000010' | X'00004114' | The <b>INITIATE OLC</b> command failed because of an error accessing the OLCSTAT data set. The online change phase might have succeeded on one or more IMS systems.<br><br>A DFS2843 message is sent to the OM output exit as unsolicited output.<br><br>For more details, see <a href="#">“INITIATE OLC error handling” on page 875.</a>   |
| X'00000010' | X'00004118' | The <b>INITIATE OLC</b> command failed because of an error allocating the OLCSTAT data set. The online change phase might have succeeded on one or more IMS systems.<br><br>A DFS2848 message is sent to the OM output exit as unsolicited output.<br><br>For more details, see <a href="#">“INITIATE OLC error handling” on page 875.</a>  |
| X'00000010' | X'0000411C' | The <b>INITIATE OLC</b> command failed because of an error in the OLCSTAT data set contents. One or more of the values is invalid.<br><br>A DFS2844 message is sent to the OM output exit as unsolicited output.  |
| X'00000010' | X'00004120' | The <b>INITIATE OLC</b> command is rejected because an online change command is already in progress on this IMS. The command in progress might be <b>INITIATE OLC</b> , <b>TERMINATE OLC</b> , or <b>/DISPLAY MODIFY</b> .  |

Table 343. Return and reason codes for INITIATE OLC (continued)

| Return code | Reason code | Meaning   |
|-------------|-------------|---|
| X'00000010' | X'00004124' | The <b>INITIATE OLC PHASE(PREPARE)</b> command is rejected, because another process of the same type is already in progress. Processes include another OLC command or a DRD command such as <b>CREATE DB</b> or <b>DELETE DB</b> for a DEDB. Wait until the other process has completed.  |
| X'00000010' | X'0000412C' | The OLCSTAT data set contains the name of an IMS other than the IMS processing the online change. Use DFSUOLC0 to correct the data set.   |
| X'00000010' | X'00004303' | At least one IMS in the OLCSTAT is at a lower level than required for the TYPE(ACBMBR) online change.   |
| X'00000010' | X'00004304' | Data set version is invalid. The OLCSTAT is initialized to an invalid version for the type of online change requested. For example, version 1 is invalid for TYPE(ACBMBR) member online change. Or, the data set is initialized to version 2 and one or more IMS systems are lower than IMS Version 10.   |
| X'00000010' | X'00004305' | IMS version mismatch. There is a mismatch between the version of the IMS in the OLCSTAT and the actual version of IMS that is currently running. The actual version of IMS is returned from the CSLSCQRY request. The OLCSTAT must be reinitialized so that the IMS is at the correct version.  |
| X'00000010' | X'0000501C' | The <b>INITIATE OLC</b> command is rejected because an IMODULE GETMAIN storage request failed.  |
| X'00000014' | X'00005000' | The <b>INITIATE OLC</b> command is rejected because an IMODULE GETSTOR storage request failed.  |
| X'00000014' | X'00005004' | The <b>INITIATE OLC</b> command failed because a DFSOCMD response buffer could not be obtained. The online change phase might have succeeded on one or more IMS systems.<br><br>For more details, see <a href="#">“INITIATE OLC error handling” on page 875.</a>  |
| X'00000014' | X'0000500C' | The <b>INITIATE OLC</b> command failed because an AWE could not be obtained.  |
| X'00000014' | X'00005100' | The <b>INITIATE OLC</b> command failed because of an RM error. The online change phase might have succeeded on one or more IMS systems. The RM error might be caused by a resource structure failure that causes RM to lose knowledge of an IMSplex-wide process.<br><br>For more details, see <a href="#">“INITIATE OLC error handling” on page 875.</a> |
| X'00000014' | X'00005104' | The <b>INITIATE OLC</b> command failed because of a CQS error. The online change phase might have succeeded on one or more IMS systems.<br><br>For more details, see <a href="#">“INITIATE OLC error handling” on page 875.</a>   |
| X'00000014' | X'00005108' | The <b>INITIATE OLC</b> command failed because of an SCI error. The online change phase might have succeeded on one or more IMS systems.<br><br>For more details, see <a href="#">“INITIATE OLC error handling” on page 875.</a>  |

Table 343. Return and reason codes for INITIATE OLC (continued)

| Return code | Reason code | Meaning  |
|-------------|-------------|--|
| X'00000014' | X'0000510C' | Another RM process step is in progress. If this reason code is returned after the previous <b>COMMIT</b> command timed out, try the <b>COMMIT</b> command again.   |
| X'00000014' | X'00005FFF' | The <b>INITIATE OLC</b> command failed because of an internal IMS error. The online change phase might have succeeded on one or more IMS systems.<br><br>For more details, see <a href="#">“INITIATE OLC error handling” on page 875</a> . |

The **INITIATE** command (with the OLC keyword) can result in errors that leave one or more of the IMS systems in the IMSplex in various online change states. The following table contains the possible completion codes that can be returned as a result of issuing an **INITIATE OLC** command. The table also includes a brief explanation of the code and provides the error text if applicable.

Table 344. Completion codes for the INITIATE OLC command

| Completion code | Meaning  | ERROR TEXT (uppercase)           |
|-----------------|--|----------------------------------|
| 0               | The online change prepare phase or commit phase completed successfully.  |                                  |
| 1               | The online change type does not apply to this IMS. For example, an FMTLIB online change does not apply to a DBCTL IMS. This IMS keeps status indicating that it is participating in the online change. This IMS is included in the OLCSTAT data set IMS list after a successful commit phase 1. For another example, a MODBLKS online change does not apply to an IMS where dynamic resource definition is enabled (DFSDFxxx or DFSCGxxx is defined with MODBLKS=DYN).   |                                  |
| 2               | The online change phase was not attempted by this IMS for one of the following reasons: <ul style="list-style-type: none"> <li>The online change phase master encountered an error and did not direct this IMS to perform the online change phase.</li> <li>The online change phase master rejected the online change because one or more IMS systems are down and the FRCNRML or FRCABND keyword was not specified on the <b>INITIATE OLC PHASE(PREPARE)</b> command. The online change phase master did not direct this IMS to perform the online change phase.</li> </ul> |                                  |
| 3               | This IMS is already in the correct online change state. The <b>INITIATE OLC</b> command must have been tried again after a previous <b>INITIATE OLC</b> command resulted in a mix of successes and failures. This IMS keeps status indicating that it is participating in the online change. This IMS is included in the OLCSTAT data set IMS list after a successful commit phase 1.  |                                  |
| 4               | The online change commit phase is incomplete on this IMS. One or more online change commit phases have been completed on this IMS. All online change commit phases were not sent to this IMS due to errors.  |                                  |
| 5               | The ACBMBR OLC is complete; however, during COMMIT processing after the OLCSTAT was updated, an error was encountered and one or more members that have been added or changed with the ACBMBR OLC are unusable. Any programs that are not usable are marked bad with a reason code of MOLCCOMMIT. Any databases that are not usable are marked bad with a reason code of MOLCFAIL.   | OLC COMPLETE, SOME MBRS UNUSABLE |

Table 344. Completion codes for the INITIATE OLC command (continued)

| Completion code | Meaning  | ERROR TEXT (uppercase)   |
|-----------------|--|--|
| 1D              | The OLC directive cannot be processed, because a takeover is in progress.  | XRF TAKEOVER IS IN PROGRESS  |
| 57              | The queue structure is unavailable. IMS is unable to check if there is a global queue count for transactions to be added, changed, or deleted. Commit is not permitted to proceed. The structure might be unavailable for one of the following reasons: <ul style="list-style-type: none"> <li>• CQS is unavailable</li> <li>• The MSGQ structure failed and it has not been rebuilt yet</li> <li>• CQS lost connectivity to the MSGQ structure</li> </ul>   | THE QUEUE STRUCTURE IS UNAVAILABLE.  |
| 58              | An IMS is not registered to RM. An OLCSTAT data set contains an IMS that is not registered to RM. The <b>INITIATE</b> command fails for that IMS.<br><br>If the <b>INITIATE OLC PHASE(PREPARE)</b> command is issued to an IMS that is registered to RM and the OLCSTAT data set contains an IMS system that is not registered to RM, the command fails. The unregistered IMS command-line response is cc=58. To initiate online change, you must remove the unregistered IMS from the OLCSTAT data set. To remove the IMS, perform the following steps: <ol style="list-style-type: none"> <li>1. Issue <b>QRY MEMBER TYPE(IMS) SHOW(ATTRIB)</b> or <b>SHOW(ALL)</b> to verify the IMS that received the cc=58 was initialized with RMENV=N.</li> <li>2. Unlock the OLCSTAT data set using the DFSUOLCO utility. When online change is in progress it is necessary for the utility to delete the invalid member name.</li> <li>3. Delete the invalid IMSID from the OLCSTAT data set using the DFSUOLCO utility.</li> <li>4. Issue <b>TERM OLC</b> to terminate the OLC with the valid IMS systems.</li> <li>5. Reissue the OLC.</li> </ol> |  |
| 60              | IMODULE GETMAIN storage error.   |  |
| 61              | DFSBCB storage error.  | <b>INTERNALBLOCK NOT BUILD</b><br>IMS was unable to get the CSA storage that is required to build the DBRC work area.  |
| 62              | HIOP storage error.  |  |
| 63              | WKAP storage error.  |  |
| 64              | GETSTOR storage error,   | <b>INTERNALBLOCK NOT BUILD</b><br>IMS was unable to get the CSA storage that is required to build an internal block that holds a list of altered HALDB master databases. |
| 70              | Module load error.   | Module name (8 characters), module type (8 characters).<br>The module type can be 'SECURITY'.  |
| 71              | Module locate error.   | Module name (8 characters), module type (8 characters).<br>The module type can be 'SECURITY'.  |
| 72              | Randomizer load error.   | FP area randomizer name (8 characters).  |

Table 344. Completion codes for the INITIATE OLC command (continued)

| Completion code | Meaning         | ERROR TEXT (uppercase)  |
|-----------------|-----------------|---|
| 80              | Data set error. | <p>Function (8 characters), ddname (8 characters), return code (8 bytes), and error detail (8 characters).</p> <p>Function can be one of the following:</p> <p><b>BLDL</b><br/>Data set BLDL error.</p> <p><b>BUSY</b><br/>The data set is busy. The detail contains the job name that has the data set.</p> <p><b>DIR</b><br/>Data set directory error.</p> <p><b>DIRSIZE ddname nn mbrname</b><br/>Where:</p> <p><b>ddname</b><br/>The 7-character FMTLIB DD name, which is either FORMATA or FORMATB.</p> <p><b>nn</b><br/>The 2-byte FMTLIB data set concatenation number within the FMTLIB DD statement.</p> <p><b>mbrname</b><br/>The 8-character invalid member name in the FMTLIB data set.</p> <p>For example, if a module is erroneously copied into the inactive FMTLIB before the <b>INITIATE OLC PHASE (COMMIT)</b> command is issued, the <b>INITIATE OLC PHASE (COMMIT)</b> command might fail with this error. If the member is an actual MFS format with an invalid directory size, the first two characters of the format name are unprintable hexadecimal values that might appear as blanks or other non-alphanumeric characters in this output. The first two characters of the format name might appear as different non-alphanumeric characters when browsing the FMTLIB with TSO.</p> <p><b>EMPTY</b><br/>Library is empty.</p> <p><b>ENQUEUE</b><br/>Data set enqueue error.</p> <p><b>EOF</b><br/>Data set end-of-file (EOF) error.</p> <p><b>OPEN</b><br/>Data set open error. Error detail can be 'DLS REG'.</p> <p><b>READ</b><br/>Data set read error.</p> <p><b>WRITE</b><br/>Data set write error.</p> <p>DDname can be ACBLIBA, ACBLIBB, FMTLIBA, FMTLIBB, MODBLKSA, MODBLKSB, or MODSTAT.</p> <p>Return code is the data set service return code.</p> <p>Reason code is the data set service reason code.</p> |
| 90              | Internal error  | <p>Module name that detected internal error (8 characters), unused (8 characters), return code or function code (8 bytes), and error detail (8 characters).</p>   |



Table 344. Completion codes for the INITIATE OLC command (continued)

| Completion code | Meaning  | ERROR TEXT (uppercase)   |
|-----------------|--|--|
| 91              | The online change prepare phase, commit phase, or abort phase timed out before this IMS responded to the online change prepare or commit phase. The online change prepare phase or commit phase might have succeeded on this IMS. Issue <b>QUERY MEMBER TYPE (IMS)</b> to determine the online change state of this IMS. |  |
| B0              | Resource definition error.   | <p>Resource type (8 characters), resource name (8 characters), error detail (16 characters).</p> <p>The resource type can be AREA, DB, DMB, PSB, SECURITY, or SMB.</p> <p>The resource name can be a resource name, ACBLIB or MODBLKS.</p> <p>The error detail can be one of the following:</p> <p><b>CISIZE ERROR</b><br/>An attempt to add the area name to the DEDB failed. The CI size of the area exceeds the Fast Path buffer size (BSIZ=) of the IMS online control region.</p> <p><b>CPCTAN CONFLICT</b><br/>The online change command attempted to add a transaction name that conflicts with a CPIC transaction name. Traname specifies the transaction that exists as a CPIC transaction.</p> <p><b>DESC CONFLICT</b><br/>The online change command attempted to add a transaction name that conflicts with a descriptor name. Traname specifies the transaction that exists as a descriptor name.</p> <p><b>DUPLICATE</b><br/>A duplicate area name was found in the named DEDB DBD defined in the IMS system. The area name, that was defined in the DD1 operand on one of the AREA statements in the DBDGEN, is defined in another DEDB DBDGEN or is defined within the DEDB DBDGEN.</p> <p><b>INCOMPATIBLE</b><br/>The DMB in the inactive ACBLIB is not compatible with IMS. The level of the inactive library is not compatible with the current IMS release.</p> <p><b>PDIR NAME</b><br/>The online change attempted to change the program name of the transaction, but the program does not exist, nor is it being added by online change. The program name for a local transaction must exist or be added with the same online change.</p> |

Table 344. Completion codes for the INITIATE OLC command (continued)

| Completion code | Meaning                                | ERROR TEXT (uppercase)   |
|-----------------|--|--|
| B0              | Resource definition error (continued). | <p><b>INCONSISTENT</b><br/>IMS detected an inconsistency between the indicated security module and the definition of the new blocks in the inactive MODBLKS data set. Either the security option was requested on the online change command or the prevailing security option is YES or FORCE. In the module name, <i>nnns</i> is the specific table name, where <i>s</i> is the suffix.</p> <p><b>LTERM CONFLICT</b><br/>The online change command attempted to add a transaction name that conflicts with a dynamic lterm name.<br/><br/>Tranname specifies the transaction that exists as a dynamically created LTERM. The error detail can be one of the following (continued):</p> <p><b>MSNAME CONFLICT</b><br/>The online change command attempted to add a transaction name that conflicts with an MSNAME. Tranname specifies the transaction that exists as an MSNAME.</p> <p><b>NOT DEFINED</b><br/>Control block was not defined in the active library during the online prepare phase. This is an internal error that should not occur.</p> <p><b>NO BLOCKS</b><br/>Control blocks were missing from the inactive library during the online prepare phase.</p> |
| B0              | Resource definition error (continued). | <p><b>NO FP INSTALLED</b><br/>An attempt was made to add a data entry database (DEDB) to an IMS system that does not have Fast Path installed.</p> <p><b>NO OTHREADS</b><br/>An attempt was made to add a data entry database (DEDB) to an IMS system that was not initialized with DEDBs. No output threads (OTHREADS) were initialized and no I/O will be possible to the added DEDB.</p> <p><b>PARTITION EXISTS</b><br/>A database partition by that name exists.</p> <p><b>RSRC CONFLICT</b><br/>The online change command is attempting to add a transaction name that conflicts with another message destination resource in the Resource Manager (RM). The resource can be an LTERM, CPIC transaction, MSNAME, or descriptor. Tranname specifies the transaction that exists as another resource type.</p> <p><b>UNSUPPORTED MSDB</b><br/>The online change attempted to add an MSDB or change a DEDB to an MSDB, which is not permitted.</p>   |
| B1              |  | <p>Resource type (8 characters), resource name (8 characters), error detail (16 characters).</p> <p>The resource name is the name of the resource as it is defined to IMS, such as the database name, the program name, or the transaction name.</p> <p>The resource type can be DATABASE, DMB, FORMAT, PROGRAM, PSB, RTCODE, or TRAN.</p>   |

Table 344. Completion codes for the INITIATE OLC command (continued)

| Completion code | Meaning   | ERROR TEXT (uppercase)   |
|-----------------|---|--|
| B1              | <p>Resource state error.</p> <p>The online change phase failed on this IMS because of the state of the specified resource.</p> <p>Many of the resource states indicate work is in progress for resources to be changed or deleted by online change. Online change commit detected a resource in a state that results in commit failure. This is the first resource for which an error is detected. IMS is returned to an online change prepare state. Issue a <b>/DISPLAY MODIFY</b> command to display the work in progress for resources to be changed or deleted by online change. Resolve the work in progress, then attempt the <b>INITIATE OLC PHASE(COMMIT)</b> command again.</p> | <p>The error detail can be one of the following:</p> <p><b>ACTIVE</b><br/>The routing code <i>rtcode</i> is active.</p> <p><b>AREA OPEN</b><br/>An area associated with the FP DEDB is open.</p> <p><b>AREA STARTED</b><br/>An area associated with the FP DEDB is started.</p> <p><b>CONVERSATION</b><br/>The transaction to be changed or deleted or the transaction referencing a program or database to be changed or deleted is in conversation.</p> <p><b>DATABASE <i>dbname</i> ALTER INCOMPLETE</b><br/>Alter processing is not complete for a HALDB database. After alter processing completes, retry the <b>INITIATE OLC</b> command.</p> <p><b>DATABASE <i>dbname</i> STG TOO SMALL</b><br/>The OLC function cannot process the altered DDIR because there is not enough internal block storage.</p> <p>The lack of storage could be caused by the start of another HALDB alter operation after OLC reaches the commit phase.</p> <p>Retry the <b>INITIATE OLC PHASE(COMMIT)</b> command.</p> <p>Error details continued in next row.</p> |
| B1              | Resource state error (continued).   | <p><b>DBD ACTIVE</b><br/>A <b>/DBDUMP</b> command is active for the database.</p> <p><b>DBR ACTIVE</b><br/>A <b>/DBRECOVERY</b> command is active for the database.</p> <p><b>DBR NEEDED</b><br/>A <b>/DBRECOVERY</b> command is needed for the database resource. Online change was initiated to either change or delete one or more HALDB databases which have not been taken offline with a <b>/DBR</b> command.</p> <p>If the IMS catalog is enabled with an alias other than DFSC (the standard alias prefix), and the catalog databases have been modified with online change, issue the <b>DBR DB</b> command for the databases IMS1D000 and IMS1X000 instead of DFSCD000 and DFSCX000.</p> <p><b>DEP REGS ACTIVE</b><br/>Dependent regions using the FP DEDB are active.</p> <p>Error details continued in next row.</p>   |

Table 344. Completion codes for the INITIATE OLC command (continued)

| Completion code | Meaning                           | ERROR TEXT (uppercase)  |
|-----------------|-----------------------------------|---|
| B1              | Resource state error (continued). | <p>Error detail (continued):</p> <p><b>DYNAMIC OR CPIC</b><br/>The transaction being added exists and is not dynamic or CPIC. This is an internal error that should not occur.</p> <p><b>ELIGIBLE SCHED</b><br/>The named transaction is eligible for scheduling and cannot be deleted by online change. Stop the transaction before attempting another online change commit.</p> <p><b>INTERNAL ERROR</b><br/>The resource control block is not found in the active IMS, or the resource control block exists. These are internal errors that should not occur.</p> <p><b>IN USE</b><br/>The resource is in use.<br/><br/>A transaction has queuing in progress (either terminal input program-to-program switch).<br/><br/>A database is in use.</p> <p><b>PSB SCHEDULED</b><br/>A program referencing a database to be changed or deleted is scheduled.</p> <p><b>QUEUEING</b><br/>Messages are queued to the transaction or program.</p> <p><b>SCHEDULED</b><br/>The named resource (a transaction or program to be changed or deleted, or a program referencing a database to be changed or deleted) is scheduled.</p> <p><b>SUSPENDED</b><br/>The transaction to be changed or deleted is on the suspend queue.</p>   |
| B2              | IMS state error.                  | <p>IMS state error (32 characters). The IMS state can be one of the following:</p> <p><b>ABENDED</b><br/>This IMS ended abnormally since the last successful online change. Online change is not permitted if any IMS ended abnormally since the last online change, unless the FRCABND option is specified on prepare. If the online change phase was rejected, issue <b>TERMINATE OLC</b> to abort the online change, correct the problem, and try the online change again. If an online change specified with the FRCABND option succeeds, this IMS might have to cold start.</p> <p><b>CHECKPOINT IN PROGRESS</b><br/>This IMS has checkpoint in progress.</p> <p><b>NOT-REACHABLE</b><br/>The online change phase is rejected because this IMS is NOT-REACHABLE. The SCI on the OS image where this IMS is active is down. Restart the SCI and reissue the <b>INITIATE OLC</b> or <b>TERMINATE OLC</b> command.</p> <p><b>OLC ALREADY COMMITTED</b><br/>The online change phase is rejected because online change is already committed. All IMS systems have completed commit phase 1 and the OLCSTAT data set was updated.</p> <p><b>OLC NOT IN PROGRESS</b><br/>The online change phase is rejected because this IMS is not in an online change state.</p> |

Table 344. Completion codes for the INITIATE OLC command (continued)

| Completion code | Meaning   | ERROR TEXT (uppercase)  |
|-----------------|---|---|
| B2              | IMS state error (continued).  | <p>IMS state error (32 characters). The IMS state can be one of the following:</p> <p><b>OLC PHASE IN PROGRESS</b><br/>The online change phase is rejected because this IMS has an online change phase already in progress.</p> <p><b>RECOVERY IN PROGRESS</b><br/>The online change command is rejected because the online recovery service is already in progress.</p> <p><b>RESOLVE DB INDOUBTS</b><br/>This IMS has DB indoubts. You must resolve the DB indoubts either by reconnecting the coordinator controller and IMS or by using an operator command.</p> <p><b>RESTART IN PROGRESS</b><br/>This IMS has restart in progress.</p> <p><b>RESTART NOT COMPLETE</b><br/>This IMS initialized before the online change was initiated, but has not completed restart. The online prepare or abort phase is rejected as long as this IMS is in this state. Cancel this IMS, then abort the online change before attempting the online change prepare phase again.</p> <p><b>SHUTDOWN</b><br/>This IMS was shut down normally since the last successful online change. Online change is not permitted if any IMS was shut down normally since the last online change, unless the FRCNRML option is specified on prepare. If the online change phase was rejected, issue <b>TERMINATE OLC</b> to terminate the online change, correct the problem, and try the online change again. If an online change specified with the FRCNRML option succeeds, this IMS might have to cold start.</p> |
| 120             | The INIT OLC TYPE(ACBMBR) online change failed.   | Staging ACBLIB is empty.  |
| 121             | The INIT OLC TYPE(ACBMBR) online change failed.   | Resource in command has no change.  |
| 122             | The INIT OLC TYPE(ACBMBR) online change failed.   | Not all PSBs are rebuilt for this DMB.  |
| 123             | The INIT OLC TYPE(ACBMBR) online change failed.   | Staging library level is not compatible with the current IMS.   |
| 124             | The INIT OLC TYPE(ACBMBR) online change failed.   | DOPT PSB will not be copied to the active ACBLIB.   |
| 125             | The INIT OLC TYPE(ACBMBR) online change failed.   | No PSB is rebuilt for this change DMB.  |
| 126             | The INIT OLC TYPE(ACBMBR) online change failed.   | The previous member OLC failed in the commit phase 1 processing. The terminate OLC command must be entered to terminate the pending member OLC.   |
| 127             | The INIT OLC TYPE(ACBMBR) online change failed.   | COMMIT MEMBER failure.  |
| 128             | The INIT OLC TYPE(ACBMBR) online change failed.   | REFRESH MBR failure.  |
| 129             | The INIT OLC TYPE(ACBMBR) online change failed.   | Mismatch in ACBSHR= values among IMS systems in the OLCSTAT.  |
| 12A             | Existing DBDs in the active ACB library cannot be modified.   | NAMEONLY DBD CHANGES NOT ALLOWED  |
| 12B             | The PSB that is specified in the command includes references to the existing DBDs that have been changed in the staging ACB library. The <b>INIT OLC</b> command failed because existing DBDs in the active ACB library cannot be modified. | NAMEONLY PSB CONTAINS CHANGED DB  |

Table 344. Completion codes for the INITIATE OLC command (continued)

| Completion code | Meaning   | ERROR TEXT (uppercase)               |
|-----------------|---|--------------------------------------|
| 12C             | The DBD that is specified in the command includes references to the existing DBDs that have been changed in the staging ACB library. The <b>INIT OLC</b> command failed because existing DBDs in the active ACB library cannot be modified.                                   | NAMEONLY DBD HAS CHNG LOGICAL DB     |
| 12D             | The online change prepare phase failed. The catalog PSB DFSCP000 cannot be deleted from the online system while the catalog is enabled. To allow the online change prepare phase to proceed, perform an ACBGEN of the staging ACBLIB with BUILD PSB=DFSCP000.                 | DELETING CATALOG PSB NOT ALLOWED     |
| 12E             | The online change prepare phase failed. The catalog DBD DFSCD000 or DFSCX000 cannot be deleted from the online system while the catalog is enabled. In order for the online change prepare phase to proceed, perform an ACBGEN with BUILD PSB=DFSCP000 to the staging ACBLIB. | DELETING CATALOG DBD NOT ALLOWED     |
| 130             | The <b>INIT OLC TYPE(ACBMBR)</b> online change failed.  | Allocation of staging ACBLIB failed. |
| 131             | The <b>INIT OLC TYPE(ACBMBR)</b> online change failed.  | Allocation of active ACBLIB failed.  |
| 132             | The <b>INIT OLC TYPE(ACBMBR)</b> online change failed.  | Open of staging ACBLIB failed.       |
| 133             | The <b>INIT OLC TYPE(ACBMBR)</b> online change failed.  | IO error of active ACBLIB.           |
| 134             | The <b>INIT OLC TYPE(ACBMBR)</b> online change failed.  | Open of active ACBLIB failed.        |
| 135             | The <b>INIT OLC TYPE(ACBMBR)</b> online change failed.  | IO error of staging ACBLIB.          |
| 136             | The <b>INIT OLC TYPE(ACBMBR)</b> online change failed because there were more than the maximum supported concatenations for the active ACB library.   |                                      |
| 138             | The <b>INIT OLC TYPE(ACBMBR) OPTION(BLDPSBNO)</b> online change failed because the specified DBD has a structural update.   | AREA HAS STRUCTURAL CHANGE           |
| 14B             | IMS is being shut down. The ACBMBR online change prepare command is terminated.   | SHUTDOWN                             |
| 180             | During an <b>INIT OLC PHASE(PREPARE)</b> command processing, the load of the DFSMDA member for the inactive ACBLIB failed. Message DFS0887A is issued on the system console.  | DATASET ERROR MDA LOAD               |
| 181             | During an <b>INIT OLC PHASE(PREPARE)</b> command processing, the allocation of the inactive ACBLIB failed. Message DFS2500W is issued on the system console.  | DATASET ERROR ALLOCATE               |

## Examples

The following are examples of the **INITIATE OLC** command.

### Example 1 for INITIATE OLC command

TSO SPOC input:

```
INITIATE OLC PHASE(PREPARE) TYPE(MODBLKS,ACBLIB)
```

TSO SPOC output:

| MbrName | Member | CC | ACBLIB | FMTLIB | MODBLKS | ModId |
|---------|--------|----|--------|--------|---------|-------|
| IMS3    | IMS2   | 0  |        |        |         |       |
| IMS3    | IMS3   | 0  | B      | A      | B       | 1     |
| IMS3    | SYS3   | 0  |        |        |         |       |

OM API input:

```
CMD (INITIATE OLC PHASE(PREPARE) TYPE(MODBLKS,ACBLIB))
```

OM API output:

```
<imsout>
<ctl>
<omname>OM10M </omname>
<omvsn>1.1.0</omvsn>
<xmlvsn>1 </xmlvsn>
<statime>2003.163 15:40:53.336327</statime>
<stotime>2003.163 15:41:08.282146</stotime>
<staseq>B7C4AC11FED070C6</staseq>
<stoseq>B7C4AC203FB220C1</stoseq>
<rqsttkn1>USRT011 10084053</rqsttkn1>
<rc>0200000C</rc>
<rsn>00003000</rsn>
</ctl>
<cmderr>
<mbr name="IMS2 ">
<typ>IMS </typ>
<styp>DBDC </styp>
<rc>02000004</rc>
<rsn>00001008</rsn>
</mbr>
<mbr name="SYS3 ">
<typ>IMS </typ>
<styp>DBDC </styp>
<rc>02000004</rc>
<rsn>00001008</rsn>
</mbr>
</cmderr>
<cmd>
<master>IMS3 </master>
<userid>USRT011 </userid>
<verb>INIT</verb>
<kwd>OLC </kwd>
<input>INITIATE OLC PHASE(PREPARE) TYPE(MODBLKS,ACBLIB)</input>
</cmd>
<cmdsphdr>
<hdr slbl="MBR" llbl="MbrName" scope="LCL" sort="n" key="0" scroll="yes" len="8"
dtype="CHAR" align="left" />
<hdr slbl="IMSMBR" llbl="Member" scope="LCL" sort="a" key="1" scroll="no" len="8"
dtype="CHAR" align="left" />
<hdr slbl="CC" llbl="CC" scope="LCL" sort="n" key="0" scroll="yes" len="4"
dtype="INT" align="right" />
<hdr slbl="ACBL" llbl="ACBLIB" scope="GBL" sort="n" key="0" scroll="yes" len="1"
dtype="CHAR" align="right" />
<hdr slbl="FMTL" llbl="FMTLIB" scope="GBL" sort="n" key="0" scroll="yes" len="1"
dtype="CHAR" align="right" />
<hdr slbl="MODB" llbl="MODBLKS" scope="GBL" sort="n" key="0" scroll="yes" len="1"
dtype="CHAR" align="right" />
<hdr slbl="MODI" llbl="ModId" scope="GBL" sort="n" key="0" scroll="yes" len="8"
dtype="CHAR" align="right" />
</cmdsphdr>
<cmdsphdata>
<rsp>MBR(IMS3 ) IMSMBR(SYS3 ) CC( 0) </rsp>
<rsp>MBR(IMS3 ) IMSMBR(IMS2 ) CC( 0) </rsp>
<rsp>MBR(IMS3 ) IMSMBR(IMS3 ) CC( 0) ACBL(B) FMTL(A) MODB(B) MODI( 1)
</rsp>
</cmdsphdata>
</imsout>
```

**Explanation:** The IMSplex consists of three IMS systems: SYS3, IMS2, and IMS3. All three of the IMS systems complete the online change prepare phase successfully for the MODBLKS library. IMS3 is the master of the prepare phase. The current online change libraries are ACBLIBB, FMTLIBA, and MODBLKSB. The current modify ID is 1.

### Example 2 for INITIATE OLC command

TSO SPOC input:

```
INITIATE OLC PHASE(COMMIT)
```

TSO SPOC output:

| MbrName | Member | CC | ACBLIB | FMTLIB | MODBLKS | ModId |
|---------|--------|----|--------|--------|---------|-------|
| IMS3    | IMS2   | 0  |        |        |         |       |
| IMS3    | IMS3   | 0  | B      | A      | A       | 2     |
| IMS3    | SYS3   | 0  |        |        |         |       |

OM API input:

```
CMD (INITIATE OLC PHASE(COMMIT))
```

OM API output:

```
<imsout>
<ctl>
<omname>OM10M </omname>
<omvsn>1.1.0</omvsn>
<xmlvsn>1 </xmlvsn>
<statime>2002.163 16:26:14.660563</statime>
<stotime>2002.16316:26:22.293891</stotime>
<staseq>B7C4B635409D30C6</staseq>
<stoseq>B7C4B63C88383347</stoseq>
<rqsttkn1>USRT011 10092614</rqsttkn1>
<rc>0200000C</rc>
<rsn>00003000</rsn>
</ctl>
<cmderr>
<mbr name="IMS2 ">
<typ>IMS </typ>
<styp>DBDC </styp>
<rc>02000004</rc>
<rsn>00001008</rsn>
</mbr>
<mbr name="SYS3 ">
<typ>IMS </typ>
<styp>DBDC </styp>
<rc>02000004</rc>
<rsn>00001008</rsn>
</mbr>
</cmderr>
<cmd>
<master>IMS3 </master>
<userid>USRT011 </userid>
<verb>INIT</verb>
<kwd>OLC </kwd>
<input>INITIATE OLC PHASE(COMMIT) </input>
</cmd>
<cmdrsphdr>
<hdr slbl="MBR" llbl="MbrName" scope="LCL" sort="n" key="0" scroll="yes" len="8"
dtype="CHAR" align="left" />
<hdr slbl="MSMBR" llbl="Member" scope="LCL" sort="a" key="1" scroll="no" len="8"
dtype="CHAR" align="left" />
<hdr slbl="CC" llbl="CC" scope="LCL" sort="n" key="0" scroll="yes" len="4"
dtype="INT" align="right" />
<hdr slbl="ACBL" llbl="ACBLIB" scope="GBL" sort="n" key="0" scroll="yes" len="1"
dtype="CHAR" align="right" />
<hdr slbl="FMTL" llbl="FMTLIB" scope="GBL" sort="n" key="0" scroll="yes" len="1"
dtype="CHAR" align="right" />
<hdr slbl="MODB" llbl="MODBLKS" scope="GBL" sort="n" key="0" scroll="yes" len="1"
dtype="CHAR" align="right" />
<hdr slbl="MODI" llbl="ModId" scope="GBL" sort="n" key="0" scroll="yes" len="8"
dtype="CHAR" align="right" />
</cmdrsphdr>
<cmdrspdata>
<rsp>MBR(IMS3 ) IMSMBR(SYS3 ) CC( 0) </rsp>
<rsp>MBR(IMS3 ) IMSMBR(IMS2 ) CC( 0) </rsp>
<rsp>MBR(IMS3 ) IMSMBR(IMS3 ) CC( 0) ACBL(B) FMTL(A) MODB(A) MODI( 2)
</rsp>
</cmdrspdata>
</imsout>
```

**Explanation:** A global online change commit is initiated and completes successfully.

### Example 3 for INITIATE OLC command

TSO SPOC input:

```
INITIATE OLC PHASE(PREPARE) TYPE(ACBMBR) NAME(OLCDB105 OLCDX111)
```



TSO SPOC output:

| MbrName | Member | CC | ACBSHR | DBDName  | PSBName  | ADD |
|---------|--------|----|--------|----------|----------|-----|
| IMS2    | IMS1   | 0  | Y      |          |          |     |
| IMS2    | IMS2   | 0  | Y      |          |          |     |
| IMS2    | IMS1   | 0  |        | OLCDB105 |          | Y   |
| IMS2    | IMS2   | 0  |        | OLCDB105 |          | Y   |
| IMS2    | IMS1   | 0  |        | OLCDB111 |          | Y   |
| IMS2    | IMS2   | 0  |        | OLCDB111 |          | Y   |
| IMS2    | IMS1   | 0  |        | OLCDI111 |          | Y   |
| IMS2    | IMS2   | 0  |        | OLCDI111 |          | Y   |
| IMS2    | IMS1   | 0  |        | OLCDX111 |          | Y   |
| IMS2    | IMS2   | 0  |        | OLCDX111 |          | Y   |
| IMS2    | IMS1   | 0  |        |          | OLCPB105 | Y   |
| IMS2    | IMS2   | 0  |        |          | OLCPB105 | Y   |
| IMS2    | IMS1   | 0  |        |          | OLCPB111 | Y   |
| IMS2    | IMS2   | 0  |        |          | OLCPB111 | Y   |

OM API input:

```
CMD (INITIATE OLC PHASE(PREPARE) TYPE(ACBMBR) NAME(OLCDB105 OLCDX111))
```

OM API output:

```
<imsout>
<ctl>
<omname>OM10M </omname>
<omvsn>1.3.0</omvsn>
<xmlvsn>20 </xmlvsn>
<statime>2006.268 17:31:50.028126</statime>
<stotime>2006.268 17:31:50.672287</stotime>
<staseq>BF75AD9623B5EAE3</staseq>
<stoseq>BF75AD96C0F9F723</stoseq>
<rqsttkn1>USRID01 10103150</rqsttkn1>
<rc>0200000C</rc>
<rsn>00003000</rsn>
<rsnmsg>CSLN023I</rsnmsg>
<rsntxt>At least one request was successful.</rsntxt>
</ctl>
<cmderr>
<mbr name="IMS1 ">
<typ>IMS </typ>
<styp>DBDC </styp>
<rc>02000004</rc>
<rsn>00001008</rsn>
<rsntxt>Command ROUTE list overridden w/ANY</rsntxt>
</mbr>
</cmderr>
<cmd>
<master>IMS2 </master>
<userid>USRID01 </userid>
<verb>INIT</verb>
<kwd>OLC </kwd>
<input>INIT OLC PHASE(PREPARE) TYPE(ACBMBR) NAME(OLCDB105 OLCDX111)
</input>
</cmd>
<cmdisphdr>
<hdr slbl="MBR" llbl="MbrName" scope="LCL" sort="n" key="0"
  scroll="yes" len="8" dtype="CHAR" align="left" />
<hdr slbl="IMSMBR" llbl="Member" scope="LCL" sort="a" key="4"
  scroll="no" len="8" dtype="CHAR" align="left" />
<hdr slbl="CC" llbl="CC" scope="LCL" sort="n" key="0" scroll="yes"
  len="4" dtype="INT" align="right" />
<hdr slbl="CCTXT" llbl="CCText" scope="LCL" sort="n" key="0"
  scroll="yes" len="*" dtype="CHAR" align="left" skipb="yes" />
<hdr slbl="ACBS" llbl="ACBSHR" scope="LCL" sort="n" key="0"
  scroll="yes" len="1" dtype="CHAR" align="left" skipb="yes" />
<hdr slbl="RSC" llbl="RSCName" scope="LCL" sort="a" key="3" scroll="no"
  len="8" dtype="CHAR" align="left" skipb="yes" />
<hdr slbl="DBD" llbl="DBDName" scope="LCL" sort="a" key="2" scroll="no"
  len="8" dtype="CHAR" align="left" skipb="yes" />
<hdr slbl="PSB" llbl="PSBName" scope="LCL" sort="a" key="1" scroll="no"
  len="8" dtype="CHAR" align="left" skipb="yes" />
<hdr slbl="ADD" llbl="ADD" scope="LCL" sort="n" key="0" scroll="yes"
  len="1" dtype="CHAR" align="left" skipb="yes" />
<hdr slbl="CHG" llbl="CHNG" scope="LCL" sort="n" key="0" scroll="yes"
  len="1" dtype="CHAR" align="left" skipb="yes" />
<hdr slbl="CPY" llbl="COPY" scope="LCL" sort="n" key="0" scroll="yes"
  len="1" dtype="CHAR" align="left" skipb="yes" />
```

```

<hdr slbl="RFS" llbl="RFSH" scope="LCL" sort="n" key="0" scroll="yes"
len="1" dtype="CHAR" align="left" skipb="yes" />
</cmdrsphdr>
<cmdrspdata>
<rsp>MBR(IMS2 ) IMSMBR(IMS1 ) CC( 0) ACBS(Y) </rsp>
<rsp>MBR(IMS2 ) IMSMBR(IMS1 ) CC( 0) DBD(OLCDB105) ADD(Y) </rsp>
<rsp>MBR(IMS2 ) IMSMBR(IMS1 ) CC( 0) DBD(OLCDX111) ADD(Y) </rsp>
<rsp>MBR(IMS2 ) IMSMBR(IMS1 ) CC( 0) DBD(OLCDB111) ADD(Y) </rsp>
<rsp>MBR(IMS2 ) IMSMBR(IMS1 ) CC( 0) DBD(OLCDI111) ADD(Y) </rsp>
<rsp>MBR(IMS2 ) IMSMBR(IMS1 ) CC( 0) PSB(OLCPB105) ADD(Y) </rsp>
<rsp>MBR(IMS2 ) IMSMBR(IMS1 ) CC( 0) PSB(OLCPB111) ADD(Y) </rsp>
<rsp>MBR(IMS2 ) IMSMBR(IMS2 ) CC( 0) ACBS(Y) </rsp>
<rsp>MBR(IMS2 ) IMSMBR(IMS2 ) CC( 0) DBD(OLCDB105) ADD(Y) </rsp>
<rsp>MBR(IMS2 ) IMSMBR(IMS2 ) CC( 0) DBD(OLCDX111) ADD(Y) </rsp>
<rsp>MBR(IMS2 ) IMSMBR(IMS2 ) CC( 0) DBD(OLCDB111) ADD(Y) </rsp>
<rsp>MBR(IMS2 ) IMSMBR(IMS2 ) CC( 0) DBD(OLCDI111) ADD(Y) </rsp>
<rsp>MBR(IMS2 ) IMSMBR(IMS2 ) CC( 0) PSB(OLCPB105) ADD(Y) </rsp>
<rsp>MBR(IMS2 ) IMSMBR(IMS2 ) CC( 0) PSB(OLCPB111) ADD(Y) </rsp>
</cmdrspdata>

```

**Explanation:** The **INIT OLC PHASE(PREPARE) TYPE(ACBMBR) NAME(OLCDB105 OLCDX111)** command is issued. IMS2 is the command master. IMS1 and IMS2 are in the OLCSTAT data set. The ACBSHR=Y is defined at all IMS systems so only the command master writes to the ACBLIB. The online change prepare phase is successful at all IMS systems. The command master returns to the OM the members that are to be added, changed, or copied from the staging ACBLIB to the active ACBLIB.

You can issue the **INIT OLC PHASE(COMMIT)** command to complete the online change.

#### Example 4 for INITIATE OLC command

TSO SPOC input:

```
INITIATE OLC PHASE(PREPARE) TYPE(ACBMBR) NAME(OLCDB105)
```

TSO SPOC output:

| MbrName | Member | CC | CCText             | ACBSHR | RSCName  | DBDName  | PSBName  | ADD |
|---------|--------|----|--------------------|--------|----------|----------|----------|-----|
| IMS2    | IMS1   | 0  |                    | N      |          |          |          |     |
| IMS2    | IMS2   | 0  |                    | N      |          |          |          |     |
| IMS2    | IMS2   | 10 | NO RESOURCES FOUND |        | OLCDB105 |          |          |     |
| IMS2    | IMS1   | 0  |                    |        |          | OLCDB105 |          | Y   |
| IMS2    | IMS1   | 0  |                    |        |          |          | OLCPB105 |     |
| Y       |        |    |                    |        |          |          |          |     |

OM API input:

```
CMD (INITIATE OLC PHASE(PREPARE) TYPE(ACBMBR) NAME(OLCDB105))
```

OM API output:

```

<imsout>
<ctl>
<omname>OM10M </omname>
<omvsn>1.3.0</omvsn>
<xmlvsn>20 </xmlvsn>
<statime>2006.268 18:08:10.305797</statime>
<stotime>2006.268 18:08:10.993076</stotime>
<staseq>BF75B5B56A1054E3</staseq>
<stoseq>BF75B5B611DB442C</stoseq>
<rqsttkn1>USRID01 10110810</rqsttkn1>
<rc>0200000C</rc>
<rsn>0000300C</rsn>
<rsnmsg>CSLN055I</rsnmsg>
<rsntxt>The command completed with warning(s).</rsntxt>
</ctl>
<cmderr>
<mbr name="IMS2 ">
<typ>IMS </typ>
<styp>DBDC </styp>
<rc>00000004</rc>
<rsn>0000100C</rsn>
<rsntxt>Some down or not applicable</rsntxt>
</mbr>
<mbr name="IMS1 ">
<typ>IMS </typ>

```

```

<styp>DBDC      </styp>
<rc>02000004</rc>
<rsn>00001008</rsn>
<rsntxt>Command ROUTE list overridden w/ANY</rsntxt>
</mbr>
</cmderr>
<cmd>
<master>IMS2      </master>
<userid>USRID01 </userid>
<verb>INIT</verb>
<kwd>OLC          </kwd>
<input>INIT OLC PHASE(PREPARE) TYPE(ACBMBR) NAME(OLCDB105) </input>
</cmd>
<cmdrsphdr>
<hdr slbl="MBR" llbl="MbrName" scope="LCL" sort="n" key="0"
  scroll="yes" len="8" dtype="CHAR" align="left" />
<hdr slbl="IMSMBR" llbl="Member" scope="LCL" sort="a" key="4"
  scroll="no" len="8" dtype="CHAR" align="left" />
<hdr slbl="CC" llbl="CC" scope="LCL" sort="n" key="0" scroll="yes"
  len="4" dtype="INT" align="right" />
<hdr slbl="CCTXT" llbl="CCText" scope="LCL" sort="n" key="0"
  scroll="yes" len="*" dtype="CHAR" align="left" skipb="yes" />
<hdr slbl="ACBS" llbl="ACBSHR" scope="LCL" sort="n" key="0"
  scroll="yes" len="1" dtype="CHAR" align="left" skipb="yes" />
<hdr slbl="RSC" llbl="RSCName" scope="LCL" sort="a" key="3" scroll="no"
  len="8" dtype="CHAR" align="left" skipb="yes" />
<hdr slbl="DBD" llbl="DBDName" scope="LCL" sort="a" key="2" scroll="no"
  len="8" dtype="CHAR" align="left" skipb="yes" />
<hdr slbl="PSB" llbl="PSBName" scope="LCL" sort="a" key="1" scroll="no"
  len="8" dtype="CHAR" align="left" skipb="yes" />
<hdr slbl="ADD" llbl="ADD" scope="LCL" sort="n" key="0" scroll="yes"
  len="1" dtype="CHAR" align="left" skipb="yes" />
<hdr slbl="CHG" llbl="CHNG" scope="LCL" sort="n" key="0" scroll="yes"
  len="1" dtype="CHAR" align="left" skipb="yes" />
<hdr slbl="CPY" llbl="COPY" scope="LCL" sort="n" key="0" scroll="yes"
  len="1" dtype="CHAR" align="left" skipb="yes" />
<hdr slbl="RFS" llbl="RFSH" scope="LCL" sort="n" key="0" scroll="yes"
  len="1" dtype="CHAR" align="left" skipb="yes" />
</cmdrsphdr>
<cmdrspdata>
<rsp>MBR(IMS2      ) IMSMBR(IMS1      ) CC(    0) ACBS(N) </rsp>
<rsp>MBR(IMS2      ) IMSMBR(IMS1      ) CC(    0) DBD(OLCDB105) ADD(Y) </rsp>
<rsp>MBR(IMS2      ) IMSMBR(IMS1      ) CC(    0) PSB(OLCPB105) ADD(Y) </rsp>
<rsp>MBR(IMS2      ) IMSMBR(IMS2      ) CC(    0) ACBS(N) </rsp>
<rsp>MBR(IMS2      ) IMSMBR(IMS2      ) CC(   10) CCTXT(NO RESOURCES FOUND)
RSC(OLCDB105) </rsp>
</cmdrspdata>
</imsout>

```

**Explanation:** The **INIT OLC PHASE(PREPARE) TYPE(ACBMBR) NAME(OLCDB105)** command is issued. IMS2 is the command master. IMS1 and IMS2 are in the OLCSTAT data set. The ACBSHR=N is defined at all IMS systems. All IMS systems will write to their own ACBLIB.

The online change prepare phase is successful at IMS1 and IMS3. The online change is not applicable at IMS2 because member DBD1 is not found in IMS2 staging ACBLIB and active ACBLIB.

All sharing IMS systems return the member information to the command master. The command master returns to the OM the members that are to be added, changed, or copied from the staging ACBLIB to the active ACBLIB.

You can issue the **INIT OLC PHASE(COMMIT)** command to complete the online change.

#### **Example 5 for INITIATE OLC command**

TSO SPOC input:

```
INITIATE OLC PHASE(PREPARE) TYPE(ACBMBR) NAME(OLCDB105 OLCDX111)
```

TSO SPOC output:

| MbrName | Member | CC | CCText                         | ACBSHR | DBDName  | PSBName | ADD |
|---------|--------|----|--------------------------------|--------|----------|---------|-----|
| IMS2    | IMS1   | 1  | CMD NOT APPLICABLE TO THIS IMS | N      |          |         |     |
| IMS2    | IMS2   | 0  |                                | N      |          |         |     |
| IMS2    | IMS2   | 0  |                                |        | OLCDB105 |         | Y   |
| IMS2    | IMS2   | 0  |                                |        | OLCDB111 |         | Y   |
| IMS2    | IMS2   | 0  |                                |        | OLCDI111 |         | Y   |
| IMS2    | IMS2   | 0  |                                |        | OLCDX111 |         | Y   |

|      |      |   |            |
|------|------|---|------------|
| IMS2 | IMS2 | 0 | OLCPB105 Y |
| IMS2 | IMS2 | 0 | OLCPB111   |
| Y    |      |   |            |

### OM API input:

```
CMD (INITIATE OLC PHASE(PREPARE) TYPE(ACBMBR) NAME(OLCDB105 OLCDX111))
```

### OM API output:

```
<imsout>
<ctl>
<omname>OM10M </omname>
<omvsn>1.3.0</omvsn>
<xmlvsn>20 </xmlvsn>
<statime>2006.275 22:29:51.356740</statime>
<stotime>2006.275 22:34:25.572982</stotime>
<staseq>BF7EBD4154744026</staseq>
<stoseq>BF7EBE46D7C761E4</stoseq>
<rqsttkn1>USRID01 10152951</rqsttkn1>
<rc>0200000C</rc>
<rsn>0000300C</rsn>
<rsnmsg>CSLN055I</rsnmsg>
<rsntxt>The command completed with warning(s).</rsntxt>
</ctl>
<cmderr>
<mbr name="IMS2 ">
<typ>IMS </typ>
<styp>DBDC </styp>
<rc>00000004</rc>
<rsn>0000100C</rsn>
<rsntxt>Some down or not applicable</rsntxt>
</mbr>
</cmderr>
<cmd>
<master>IMS2 </master>
<userid>USRID01 </userid>
<verb>INIT</verb>
<kwd>OLC </kwd>
<input>INITIATE OLC PHASE(PREPARE) TYPE(ACBMBR) NAME(OLCDB105 OLCDX111)
</input>
</cmd>
<cmdrsphdr>
<hdr slbl="MBR" llbl="MbrName" scope="LCL" sort="n" key="0"
scroll="yes" len="8" dtype="CHAR" align="left" />
<hdr slbl="MSMBR" llbl="Member" scope="LCL" sort="a" key="4"
scroll="no" len="8" dtype="CHAR" align="left" />
<hdr slbl="CC" llbl="CC" scope="LCL" sort="n" key="0" scroll="yes"
len="4" dtype="INT" align="right" />
<hdr slbl="CCTXT" llbl="CCText" scope="LCL" sort="n" key="0"
scroll="yes" len="*" dtype="CHAR" align="left" skipb="yes" />
<hdr slbl="ACBS" llbl="ACBSHR" scope="LCL" sort="n" key="0"
scroll="yes" len="1" dtype="CHAR" align="left" skipb="yes" />
<hdr slbl="RSC" llbl="RSCName" scope="LCL" sort="a" key="3" scroll="no"
len="8" dtype="CHAR" align="left" skipb="yes" />

<hdr slbl="DBD" llbl="DBDName" scope="LCL" sort="a" key="2" scroll="no"
len="8" dtype="CHAR" align="left" skipb="yes" />
<hdr slbl="PSB" llbl="PSBName" scope="LCL" sort="a" key="1" scroll="no"
len="8" dtype="CHAR" align="left" skipb="yes" />
<hdr slbl="ADD" llbl="ADD" scope="LCL" sort="n" key="0" scroll="yes"
len="1" dtype="CHAR" align="left" skipb="yes" />
<hdr slbl="CHG" llbl="CHNG" scope="LCL" sort="n" key="0" scroll="yes"
len="1" dtype="CHAR" align="left" skipb="yes" />
<hdr slbl="CPY" llbl="COPY" scope="LCL" sort="n" key="0" scroll="yes"
len="1" dtype="CHAR" align="left" skipb="yes" />
<hdr slbl="RFS" llbl="RFSH" scope="LCL" sort="n" key="0" scroll="yes"
len="1" dtype="CHAR" align="left" skipb="yes" />
</cmdrsphdr>
<cmdrspdata>
<rsp>MBR(IMS2 ) IMSMBR(IMS1 ) CC( 1) CCTXT(CMD NOT APPLICABLE
TO THIS IMS) ACBS(N) </rsp>
<rsp>MBR(IMS2 ) IMSMBR(IMS2 ) CC( 0) ACBS(N) </rsp>
<rsp>MBR(IMS2 ) IMSMBR(IMS2 ) CC( 0) DBD(OLCDB105) ADD(Y) </rsp>
<rsp>MBR(IMS2 ) IMSMBR(IMS2 ) CC( 0) DBD(OLCDX111) ADD(Y) </rsp>
<rsp>MBR(IMS2 ) IMSMBR(IMS2 ) CC( 0) DBD(OLCDB111) ADD(Y) </rsp>
<rsp>MBR(IMS2 ) IMSMBR(IMS2 ) CC( 0) DBD(OLCDI111) ADD(Y) </rsp>
<rsp>MBR(IMS2 ) IMSMBR(IMS2 ) CC( 0) PSB(OLCPB105) ADD(Y) </rsp>
<rsp>MBR(IMS2 ) IMSMBR(IMS2 ) CC( 0) PSB(OLCPB111) ADD(Y) </rsp>
```

```
</cmdrspdata>
</imsout>
```

**Explanation:** The **INIT OLC PHASE(PREPARE) TYPE(ACBMBR) NAME(OLCDB105 OLCDX111)** command is issued. IMS2 is the command master. IMS1 and IMS2 are in the OLCSTAT data set. The ACBSHR=N is defined at all IMS systems. All IMS systems will write to their own ACBLIB.

The online change prepare phase is successful at IMS1 and IMS3. The online change prepare phase fails at IMS2 because PSBY is not found in IMS2 staging ACBLIB and PSBY is found in IMS2 active ACBLIB. This implies a member deletion for PSBY. The command fails with a return and reason code of LIST | SOME because member online change does not support deleting members.

All sharing IMS systems return the member information to the command master. The command master returns to the OM the members that are to be added, changed, or copied from the staging ACBLIB to the active ACBLIB.

You must issue the **TERM OLC** command to terminate the online change. You must add PSBY to the staging ACBLIB for member online change or perform a full library switch online change to have PSBY deleted.

**Explanation:** The **INIT OLC PHASE(PREPARE) TYPE(ACBMBR) NAME(OLCDB105)** command is issued. IMS2 is the command master. IMS1 and IMS2 are in the OLCSTAT data set. The ACBSHR=N is defined at all IMS systems. All IMS systems will write to their own ACBLIB.

The online change prepare phase is successful at IMS1 and IMS3. The online change is not applicable at IMS2 because member DBD1 is not found in IMS2 staging ACBLIB and active ACBLIB.

All sharing IMS systems return the member information to the command master. The command master returns to the OM the members that are to be added, changed, or copied from the staging ACBLIB to the active ACBLIB.

You can issue the **INIT OLC PHASE(COMMIT)** command to complete the online change.

#### **Example 6 for INITIATE OLC command**

TSO SPOC input:

```
INIT OLC PHASE(PREPARE) TYPE(ACBMBR) NAME(ECHOPGM,ECHODBD) OPTION(NAMEONLY)
```

TSO SPOC output:

| MbrName | Member | CC | ACBSHR | DBDName | PSBName | ADD |
|---------|--------|----|--------|---------|---------|-----|
| IMS1    | IMS1   | 0  | N      |         |         |     |
| IMS1    | IMS1   | 0  |        | ECHODBD |         | Y   |
| IMS1    | IMS1   | 0  |        |         | ECHOPGM | Y   |

OM API input:

```
INIT OLC PHASE(PREPARE) TYPE(ACBMBR) NAME(ECHOPGM,ECHODBD) OPTION(NAMEONLY)
```

OM API output:

```
<cmdrsphdr>
<hdr slbl="MBR" llbl="MbrName" scope="LCL" sort="n" key="0"
  scroll="yes" len="8" dtype="CHAR" align="left" />
<hdr slbl="MSMBR" llbl="Member" scope="LCL" sort="a" key="4"
  scroll="no" len="8" dtype="CHAR" align="left" />
<hdr slbl="CC" llbl="CC" scope="LCL" sort="n" key="0" scroll="yes"
  len="4" dtype="INT" align="right" />
<hdr slbl="CCTXT" llbl="CCText" scope="LCL" sort="n" key="0"
  scroll="yes" len="*" dtype="CHAR" align="left" skipb="yes" />
<hdr slbl="ACBS" llbl="ACBSHR" scope="LCL" sort="n" key="0"
  scroll="yes" len="1" dtype="CHAR" align="left" skipb="yes" />
<hdr slbl="RSC" llbl="RSCName" scope="LCL" sort="a" key="3" scroll="no"
  len="8" dtype="CHAR" align="left" skipb="yes" />
<hdr slbl="DBD" llbl="DBDName" scope="LCL" sort="a" key="2" scroll="no"
  len="8" dtype="CHAR" align="left" skipb="yes" />
<hdr slbl="PSB" llbl="PSBName" scope="LCL" sort="a" key="1" scroll="no"
  len="8" dtype="CHAR" align="left" skipb="yes" />
<hdr slbl="ADD" llbl="ADD" scope="LCL" sort="n" key="0" scroll="yes"
```

```

    len="1" dtype="CHAR" align="left" skipb="yes" />
<hdr slbl="CHG" llbl="CHNG" scope="LCL" sort="n" key="0" scroll="yes"
    len="1" dtype="CHAR" align="left" skipb="yes" />
<hdr slbl="CPY" llbl="COPY" scope="LCL" sort="n" key="0" scroll="yes"
    len="1" dtype="CHAR" align="left" skipb="yes" />
<hdr slbl="RFS" llbl="RFSH" scope="LCL" sort="n" key="0" scroll="yes"
    len="1" dtype="CHAR" align="left" skipb="yes" />
</cmdrpsphdr>
<cmdrpspdata>
<rsp>MBR(IMS1      ) IMSMBR(IMS1      ) CC(    0) ACBS(N) </rsp>
<rsp>MBR(IMS1      ) IMSMBR(IMS1      ) CC(    0) PSB(ECHOPGM ) CPY(Y) </rsp>
<rsp>MBR(IMS1      ) IMSMBR(IMS1      ) CC(    0) DBD(ECHODBD ) CPY(Y) </rsp>
</cmdrpspdata>

```

**Explanation:** PSB ECHOPGM and DBD ECHOPGM are specified to be added to the active ACB library. These are new to the active ACB library.

### Example 7 for INITIATE OLC command

TSO SPOC input:

```
INIT OLC PHASE(PREPARE) TYPE(ACBMBR) NAME(ECHODBD) OPTION(NAMEONLY)
```

TSO SPOC output:

| MbrName | Member | CC  | CCText                           | ACBSHR | DBDName |
|---------|--------|-----|----------------------------------|--------|---------|
| IMS1    | IMS1   | 0   |                                  | N      |         |
| IMS1    | IMS1   | 12A | NAMEONLY DBD CHANGES NOT ALLOWED |        |         |
| ECHODBD |        |     |                                  |        |         |

OM API input:

```
INIT OLC PHASE(PREPARE) TYPE(ACBMBR) NAME(ECHODBD) OPTION(NAMEONLY)
```

OM API output:

```

<cmdrpsphdr>
<hdr slbl="MBR" llbl="MbrName" scope="LCL" sort="n" key="0"
    scroll="yes" len="8" dtype="CHAR" align="left" />
<hdr slbl="IMSMBR" llbl="Member" scope="LCL" sort="a" key="4"
    scroll="no" len="8" dtype="CHAR" align="left" />
<hdr slbl="CC" llbl="CC" scope="LCL" sort="n" key="0" scroll="yes"
    len="4" dtype="INT" align="right" />
<hdr slbl="CCTXT" llbl="CCText" scope="LCL" sort="n" key="0"
    scroll="yes" len="*" dtype="CHAR" align="left" skipb="yes" />
<hdr slbl="ACBS" llbl="ACBSHR" scope="LCL" sort="n" key="0"
    scroll="yes" len="1" dtype="CHAR" align="left" skipb="yes" />
<hdr slbl="RSC" llbl="RSCName" scope="LCL" sort="a" key="3" scroll="no"
    len="8" dtype="CHAR" align="left" skipb="yes" />
<hdr slbl="DBD" llbl="DBDName" scope="LCL" sort="a" key="2" scroll="no"
    len="8" dtype="CHAR" align="left" skipb="yes" />
<hdr slbl="PSB" llbl="PSBName" scope="LCL" sort="a" key="1" scroll="no"
    len="8" dtype="CHAR" align="left" skipb="yes" />
<hdr slbl="ADD" llbl="ADD" scope="LCL" sort="n" key="0" scroll="yes"
    len="1" dtype="CHAR" align="left" skipb="yes" />
<hdr slbl="CHG" llbl="CHNG" scope="LCL" sort="n" key="0" scroll="yes"
    len="1" dtype="CHAR" align="left" skipb="yes" />
<hdr slbl="CPY" llbl="COPY" scope="LCL" sort="n" key="0" scroll="yes"
    len="1" dtype="CHAR" align="left" skipb="yes" />
<hdr slbl="RFS" llbl="RFSH" scope="LCL" sort="n" key="0" scroll="yes"
    len="1" dtype="CHAR" align="left" skipb="yes" />
</cmdrpsphdr>
<cmdrpspdata>
<rsp>MBR(IMS1      ) IMSMBR(IMS1      ) CC(    0) ACBS(N) </rsp>
<rsp>MBR(IMS1      ) IMSMBR(IMS1      ) CC( 12A) CCTXT(NAMEONLY DBD CHANGES
    NOT ALLOWED) DBD(ECHODBD ) (Y) </rsp>
</cmdrpspdata>

```

**Explanation:** ECHODBD already exists in the active ACB library. ECHODBD is not in the MODBLKS library.

### Example 8 for INITIATE OLC command

In the following example, the **INIT OLC PHASE(PREPARE) TYPE(MODBLKS,ACBLIB)** command is issued in an IMSplex that has two IMS systems with DRD and IMS management of ACBs enabled. The

**PREPARE** phase fails as the command is not applicable in the environment. The **COMMIT** fails as there is no OLC to commit. The OLC must be terminated.

```
INIT OLC PHASE(PREPARE) TYPE(MODBLKS,ACBLIB)
MbrName Member CC CCText
IMS1 IMS2 1 CMD NOT APPLICABLE TO THIS IMS
IMS2 IMS2 1 CMD NOT APPLICABLE TO THIS IMS

INIT OLC PHASE(COMMIT)
MbrName Member CC CCText
IMS1 IMS2 1 CMD NOT APPLICABLE TO THIS IMS
IMS2 IMS2 1 CMD NOT APPLICABLE TO THIS IMS

TERM OLC
MbrName Member CC
IMS1 IMS2 0
IMS2 IMS2 0
```

### Example 9 for INITIATE OLC command

In the following example, the **TYPE(ALL)** is specified on the command in an environment where ACBLIB is not used because the IMS management of ACBs is enabled, but MODBLKS OLC and FMTLIB OLC are enabled. The OLC for the ACBLIB is ignored.

```
INIT OLC PHASE(PREPARE) TYPE(ALL)
MbrName Member CC ACBLIB FMTLIB MODBLKS ModId
SYS3 SYS3 0 A A A 5

INIT OLC PHASE(COMMIT)
MbrName Member CC ACBLIB FMTLIB MODBLKS ModId
SYS3 SYS3 0 B B B 6
```

### Related concepts

[How to interpret CSL request return and reason codes \(System Programming APIs\)](#)

### Related reference

[“Command keywords and their synonyms” on page 59](#)

All IMS command keywords and their synonyms, as well as keywords supported by the OM API, are listed. The list covers command keywords for the OM command processing clients such as IMS, ODBM, IMSCON, and RM.

[“/MODIFY command” on page 899](#) For detailed information about PREPARE and COMMIT parameters, see this topic.

[Global Online Change utility \(DFSUOLC0\) \(System Utilities\)](#)

## INITIATE OLC error handling

The **INITIATE OLC** command can result in errors that leave one or more of the IMS systems in the IMSplex in various online change states. Issue the **QUERY MEMBER** command and the **QUERY OLC** command to help you determine whether to terminate the online change or try the **INITIATE OLC** command again.

Before attempting online change, issue the **QUERY OLC LIBRARY(OLCSTAT) SHOW(MODID)** command to get the current modify id. If the **INITIATE OLC** command fails, issue the **QUERY OLC LIBRARY(OLCSTAT) SHOW(MODID)** command again, to see if the modify id is the same. If the modify id increased by 1, the online change is considered to be successfully completed.

If the **INITIATE OLC** command fails, issue the **QUERY MEMBER TYPE(IMS) SHOW(STATUS)** command to display the online change state of all the IMS systems in the IMSplex. Evaluate the **QUERY MEMBER TYPE(IMS) SHOW(STATUS)** output to help you to determine what to do:

- None of the IMS systems in an online change state

If the **INITIATE OLC PHASE(PREPARE)** command failed on all of the IMS systems in the IMSplex, none of them are in an online change state. This **QUERY OLC LIBRARY(OLCSTAT) SHOW(MODID)** command output shows the same modify id as the **QUERY OLC LIBRARY(OLCSTAT) SHOW(MODID)**

command issued before the **INITIATE OLC PHASE(PREPARE)** command. If you want to attempt online change again, issue another **INITIATE OLC PHASE(PREPARE)** command.

If an **INITIATE OLC PHASE(COMMIT)** command successfully completes commit phase 3 on all the IMS systems but fails because of an error such as a command timeout, then no IMS will remain in an online change state. The **QUERY MEMBER TYPE(IMS) SHOW(STATUS)** command output shows no IMS in an online change state, so no further action is needed. The online change successfully completed.

If an **INITIATE OLC PHASE(PREPARE)** command failed for all the IMS systems in the IMSplex, but Resource Manager (RM) still has information about the process, then the online change needs to be terminated. This is a very rare case where the command master initiates the online change process with RM, an error occurs, or the online change prepare phase fails on all the IMS systems, and the command master is unable to terminate the online change process with RM. RM issues a CSLR2200 message but no CSLR2201 message. The **QUERY MEMBER TYPE(IMS) SHOW(STATUS)** command output shows no IMS in an online change state. If you try to initiate an online change again with another **INITIATE OLC PHASE(PREPARE)** command, it is rejected. You must terminate the online change with a **TERMINATE OLC** command.

- Some of the IMS systems in a prepare complete state

If the **INITIATE OLC PHASE(PREPARE)** command fails and some of the IMS systems show a status of online change prepare complete (OLCPREPC), then the prepare phase succeeded on some of the IMS systems. You must terminate the online change with the **TERMINATE OLC** command. The IMS systems that have a status of OLCPREPC remain in an online change prepare complete state until you abort the online change.

- All IMS systems in a prepare complete state

If the **INITIATE OLC PHASE(PREPARE)** or **INITIATE OLC PHASE(COMMIT)** command fails and all of the IMS systems are in a prepare complete state (OLCPREPC) and the master shows a global status of online change prepare complete (OLCPREPC), then the prepare succeeded. You can issue **INITIATE OLC PHASE(COMMIT)** if you want to proceed with the online change. You can issue **TERMINATE OLC** if you want to abort the online change.

If the specified **INITIATE OLC PHASE(PREPARE)** command did not apply to any IMS in the IMSplex, the command is rejected, but all of the IMS systems show a status of OLCPREPC. For example, if the IMSplex consists of only DBCTL subsystems, then the **INITIATE OLC PHASE(PREPARE) TYPE(FMTLIB)** command does not apply to any of the IMS systems and is rejected. However, all of the IMS systems will show a status of OLCPREPC, indicating they are participating in the online change. If this situation occurs, you must terminate the online change. **INITIATE OLC PHASE(COMMIT)** will be rejected, since the online change applies to no IMS in the IMSplex.

- Some IMS systems in prepare complete and commit phase 1 complete state

If an **INITIATE OLC PHASE(COMMIT)** command fails during commit phase 1, some of the IMS systems may be in a prepare complete state (OLCPREPC) and some of the IMS systems may be in a commit phase 1 complete state (OLCCMT1C). The commit phase failed before the master updated the OLCSTAT data set, so the online change is not committed. You may correct the problem and try the commit again with the **INITIATE OLC PHASE(COMMIT)** command. Or, you may decide to abort the online change with the **TERMINATE OLC** command.

The IMS systems that are in an online change state remain in an online change state until you abort the online change or commit the online change.

- All IMS systems in a commit phase 1 complete state

If an **INITIATE OLC PHASE(COMMIT)** command fails after commit phase 1 is completed, all of the IMS systems are in a commit phase 1 complete state (OLCCMT1C).

If the error occurs before the master updates the OLCSTAT data set, then the online change is not yet successful. You may abort the online change with the **TERMINATE OLC** command or attempt the commit again with another **INITIATE OLC PHASE(COMMIT)** command.



If the error occurs after the master updates the OLCSTAT data set, then the online change is successful. You may not abort the online change. You must attempt the commit again with another **INITIATE OLC PHASE(COMMIT)** command to finish up the online change. The **INITIATE OLC PHASE(COMMIT)** command finishes the online change by completing commit phase 2.

The IMS systems that are in an online change state remain in an online change state until you abort the online change or commit the online change.

You can determine if the OLCSTAT data set has been updated by checking the modify id. Issue the **QUERY OLC LIBRARY(OLCSTAT) SHOW(MODID)** command. Check if the modify id returned is different from the modify id returned by the **INITIATE OLC PHASE(PREPARE)** command, or the modify id returned by a **QUERY OLC LIBRARY(OLCSTAT) SHOW(MODID)** command issued before the **INITIATE OLC PHASE(COMMIT)** command.

- Some IMS systems in commit phase 1 complete state and some in commit phase 2 complete state

If an **INITIATE OLC PHASE(COMMIT)** command fails during commit phase 2, some of the IMS systems may be in a commit phase 1 complete state (OLCCMT1C) and some may have completed commit phase 2 and be in a commit phase2 complete state (OLCCMT2C). The **INITIATE OLC PHASE(COMMIT)** command failed after commit phase 1 completed on all of the IMS systems and the master updated the OLCSTAT data set. Once the OLCSTAT data set is updated, the online change is considered to be successful and cannot be aborted. You must finish the online change commit phase 2 by issuing the **INITIATE OLC PHASE(COMMIT)** command again. The **INITIATE OLC PHASE(COMMIT)** command finishes the online change by completing commit phase 2.

The IMS systems that are in an online change state remain in an online change state until you finish the online change with an **INITIATE OLC PHASE(COMMIT)** command.

- All IMS systems in commit phase 2 complete state

If an **INITIATE OLC PHASE(COMMIT)** command fails during commit phase 2 or commit phase 3, all of the IMS systems may end up in a commit phase 2 complete state (OLCCMT2C). The **INITIATE OLC PHASE(COMMIT)** command failed after commit phase 1 completed on all of the IMS systems and the master updated the OLCSTAT data set. Once the OLCSTAT data set is updated, the online change is considered to be successful and can not be aborted. you must finish the online change commit phase 2 and commit phase 3 by issuing the **INITIATE OLC PHASE(COMMIT)** command again.

The IMS systems that are in an online change state remain in an online change state until you finish the online change with an **INITIATE OLC PHASE(COMMIT)** command.

- Some IMS systems in commit phase 2 complete state and some not in online change state

If an **INITIATE OLC PHASE(COMMIT)** command fails during commit phase 3, some of the IMS systems may be in a commit phase 2 complete state (OLCCMT2C) and some may have completed commit phase 3 and no longer be in an online change state. The **INITIATE OLC PHASE(COMMIT)** command failed after commit phase 1 completed on all of the IMS systems and master updated the OLCSTAT data set. Once the OLCSTAT data set is updated, the online change is considered to be successful and can not be aborted. You must finish the online change commit phase 3 by issuing the **INITIATE OLC PHASE(COMMIT)** command again, routing it to an IMS that is still in a commit phase 2 complete state. The **INITIATE OLC PHASE(COMMIT)** command finishes the online change by completing commit phase 3.

The IMS systems that are in an online change state remain in an online change state until you finish the online change with an **INITIATE OLC PHASE(COMMIT)** command.

- One IMS in commit phase 3 failed state

If an **INITIATE OLC PHASE(COMMIT)** command fails during commit phase 3 and the command master associated with this command determines the command was not successful at other IMS systems, the commit phase 3 fails and the command master exits with an error. At this point, the command master is left in an online change state. Issue another **INITIATE OLC PHASE(COMMIT)** command routed to the master (perhaps with a longer command timeout value) to complete the commit phase 3 cleanup of online change information.

Errors unique to the processing of this command are returned as a completion code. A completion code is returned for an IMS participating in the online change phase.

## INITIATE OLREORG command

Use the **INITIATE OLREORG** command to reorganize online HALDB PHDAM or PHIDAM partitions or to alter the definition of an online HALDB database.

This command can be issued in either a type-1 format (**/INITIATE OLREORG**) or a type-2 format (**INITIATE OLREORG**).

The ALTER option is supported only by the type-2 format of the command.

Subsections:

- [“Environment” on page 878](#)
- [“Syntax” on page 878](#)
- [“Keywords” on page 879](#)
- [“Usage notes” on page 881](#)
- [“Command responses for /INITIATE OLREORG” on page 881](#)
- [“Output fields” on page 882](#)
- [“Return, reason, and completion codes” on page 882](#)
- [“Examples” on page 885](#)

### Environment

The following table lists the environments (DB/DC, DBCTL, and DCCTL) from which the **INITIATE** command and keywords can be issued.

Table 345. Valid environments for the INITIATE OLREORG command and keywords

| Command / Keywords      | DB/DC | DBCTL | DCCTL |
|-------------------------|-------|-------|-------|
| <b>INITIATE OLREORG</b> | X     | X     |       |
| NAME                    | X     | X     |       |
| SET                     | X     | X     |       |
| OPTION                  | X     | X     |       |

### Syntax

#### Reorganize online HALDB PHDAM or PHIDAM partitions

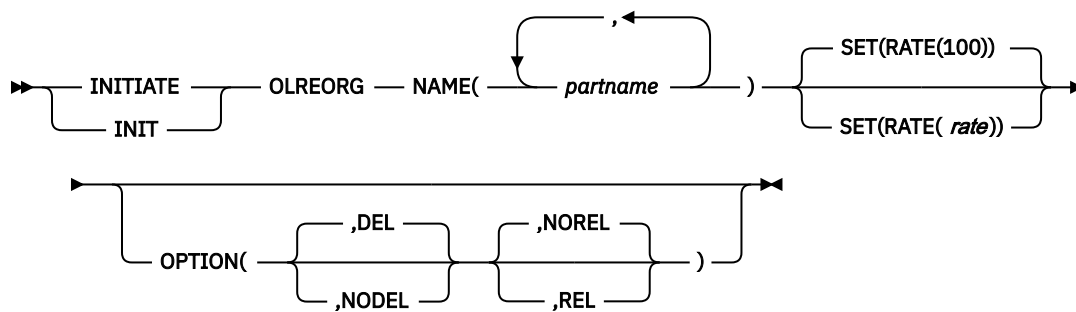

#### Alter the definition of an online HALDB database

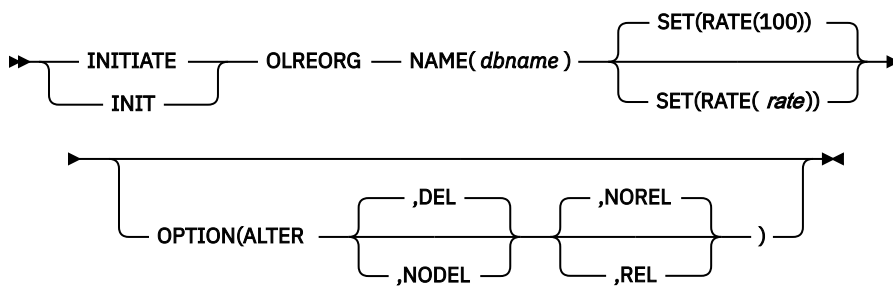

## Keywords

The following keywords are valid for the **/INITIATE OLREORG** command:

### NAME()

The name of a HALDB partition or, when **OPTION(ALTER)** is specified, the name of a HALDB master database.

You can specify only PHDAM or PHIDAM partition names. You cannot use the wildcard character (\*). For example, you cannot specify DBPART\*.

When you use the type-2 version of this command, you can specify multiple partition names.

When you use the type-1 version of this command, you can specify only one partition name.

### SET(RATE)

Specifies the RATE at which the HALDB OLR runs.

#### rate

You can specify a value of 1 to 100 for the rate values. A HALDB OLRs impact on the system is affected by the available system resources, by total system utilization (including other HALDB OLRs), by total logging volume, by log contention, and by the intensity at which this reorganization was requested to run. These same factors also affect the speed at which the reorganization runs.

You can use the RATE parameter to control the intensity at which the reorganization runs. This can affect both the reorganization's speed and its impact on the rest of the system. The value you specify for rate is the percentage of elapsed time to be devoted to copying records. The remaining time is to be an intentionally introduced delay in the copying process that minimizes the reorganization's impact on other IMS work and on the whole system.

A rate value of 50 specifies that 50% of the elapsed time be spent copying records and the remaining 50% be spent in a delay. This causes the reorganization to run approximately twice as long as it would have run with a rate value of 100.

RATE(100) is the default.

### OPTION()

You can specify the following values on the **OPTION** keyword:

#### ALTER

Applies changes that have been made to a database definition, such as an increase in the size of a segment, to an online database via the online reorganization process.

Prior to specifying the **ALTER** option when the IMS management of ACBs is enabled, the changes must be defined by using one of the following methods:

- Submitting SQL DDL statements.

- Running one of the IMS catalog population utilities with the MANAGEDACBS=STAGED control statement referenced by the SYSINP DD statement.

The new ACB member for the database must be in the staging data set of the IMS catalog.

Prior to specifying the ALTER option when ACB libraries are used, the changes must be defined in DBD generation macros, and both DBD and ACB generation must be complete. The new ACB member for the database must be in the ACB staging library.

When the ALTER keyword is specified, the name of the HALDB master database must be specified on the NAME parameter of the INITIATE OLREORG command. All of the partitions in the database are reorganized.

#### **Restrictions:**

The ALTER keyword is supported only by the type-2 version of the INITIATE OLREORG command.

The ALTER keyword cannot be specified when one or more partition names are specified on the NAME parameter.

### **DEL|NODEL**

Specifies whether IMS attempts to delete the inactive data sets after the reorganization process is complete. DEL and NODEL are mutually exclusive keywords.

When DEL is specified, IMS attempts to delete the inactive data sets when the reorganization process is complete. IMS attempts to delete the data sets regardless of who created the data sets or when the data sets were created.

When NODEL is specified, IMS does not attempt to delete the inactive data sets when the reorganization process is complete.



**Attention:** If the HALDB OLR is stopped before completion, the **OPTION(NODEL)** specification is not retained by IMS. You must specify **OPTION(NODEL)** on the **INITIATE OLREORG** command to resume the stopped HALDB OLR. You can also specify **OPTION(NODEL)** on the **UPDATE OLREORG** command.

### **REL|NOREL**

Specifies whether the IMS system releases or retains the ownership of the reorganization process if IMS shuts down or terminates before the reorganization process is complete. REL and NOREL are mutually exclusive keywords.

Specifying OPTION(REL) or OPTION(NOREL) with this command overrides any setting in the database section of the DFSDfxxx member of the IMS PROCLIB data set.

#### **NOREL**

Specifies that the IMS system retains ownership of the reorganization when it shuts down or terminates. NOREL is the default.

#### **REL**

Specifies that the IMS system releases ownership of the reorganization process if it terminates before the reorganization is completed. Specifying this keyword allows any IMS system to resume the suspended reorganization.

The **LIST.DB DBD(partition\_database)** command shows the owning IMS (OLRIMSID=*ssid*). **RELEASE OLR OWNERSHIP** is also displayed when an OLR is owned and the REL option is active for the OLR.

When OLR is active and running on an IMS and the IMS terminates abnormally, and if release OLR ownership is requested, the **LIST.DB** command will show OLRIMSID=*ssid* (instead of OLRIMSID=NULL) and **RELEASE OLR OWNERSHIP** because IMS was unable to request OLR ownership release.

**Requesting release OLR ownership in an XRF environment:** In an XRF environment, if release OLR ownership is requested while OLR is running on an active IMS, OLR will not automatically

resume on the new active IMS after an XRF takeover occurs. You must issue the **INIT OLREORG** command again on the new active IMS.

## Usage notes

HALDB OLR is not supported for PHDAM and PHIDAM databases that use 8-GB OSAM data sets.

When **OPTION(ALTER)** is specified, before the command is issued, the ACB members that contain the altered database definition must be in the staging ACB library. After alter processing is complete, Online Change must be performed to activate the ACB members and complete the alter process.

When the **/INITIATE OLREORG** command is complete and the integrated HALDB Online Reorganization function (OLR) is initiated successfully, a DFS0725I message with a completion code of 0 is sent back to the system console and the MTO as an asynchronous message. If the **/INITIATE OLREORG** command is issued from a terminal that is not the MTO or system console, the DFS0725I message is also sent to the terminal asynchronously. The DFS0725I message is not sent back to an AOI program that issues the **/INITIATE OLREORG** command. If the **/INITIATE OLREORG** command is issued from an LU 6.2 application, the LU 6.2 program receives the DFS0725I message followed by the DFS058I INITIATE COMMAND COMPLETED message.

When **OPTION(ALTER)** is specified, DFS3197I is also issued to indicate the start of alter processing. When alter processing completes or otherwise stops, DFS3198I is issued.

A type X'22' log record is created when **INITIATE OLREORG** is issued. The command is non-recoverable and is not reprocessed when IMS is restarted.

The type-1 **/INIT OLREORG** command can be entered at an IMS terminal, MTO, system console, APPC, OTMA application, or a CMD or ICMD call. You can issue **/INIT OLREORG** as a type-1 command from a non-OM API using the first three command characters; for example, **/INI OLREORG**. The type-1 command is processed at the IMS where the command was entered. However, when you issue **INIT OLREORG** as a type-2 command from an OM API, the only valid command verb form is **INIT** or **INITIATE**.

This command can be issued to an IMSplex by using the Batch SPOC utility.

While the database is being quiesced, this command cannot be processed successfully.

Part of the HALDB OLR processing involves:

- The creation of the output data sets at the beginning of the online reorganization
- The optional deletion of the inactive data sets when the HALDB OLR is completed

The output for this command is defined in XML and is available to automation programs that communicate with OM if the command is entered from OM API. When entered as a type-1 command, the command output is in message format.

When a HALDB OLR is completed, a DFS2974I message is sent to the system console indicating that the OLR is complete. The command response indicates if an OLR is initiated.

## Command responses for /INITIATE OLREORG

When you issue the type-1 **/INITIATE OLREORG** command, the command response is returned in a message format.

When the command is completed successfully, message DFS0725I with a completion code of 0 is returned to the system console and to the master terminal. If the command results in an error, a nonzero completion code or an error message is returned to the master terminal and system console.

If the command results in an error, an error message is returned to the entering terminal. One or more of the following messages might also be returned:

```
DFS0725I INITIATE|UPDATE|TERMINATE OLREORG COMMAND FOR DB dbnamexx COMPLETE.
CC= nn
  where: dbnamexx is the HALDB partition name entered on the command
         nn       is the completion code
```

```

DFS058 - INITIATE COMMAND IN PROGRESS
DFS107 - REQUIRED KEYWORD NOT PRESENT
DFS110 - COMMAND KEYWORD OLREORG INVALID FOR yyyyyyyy (tracker, XRF alt)
DFS128 - TOO FEW KEYWORDS
DFS136 - COMMAND xxxxxxxxxxxx INVALID FOR yyyyyyyy (tracker, XRF alt)
DFS165 - COMMAND VERB IS INVALID
DFS2026 - NO WKAP STORAGE
DFS2038 - INSUFFICIENT STORAGE AVAILABLE TO PROCESS COMMAND
DFS2262 - TOO MANY DATABASE PARAMETERS
DFS3630 - GENERIC PARAMETER NOT ALLOWED

```

## Output fields

This section describes the responses from the OM API for the **INITIATE OLREORG** command. The following table shows the **INITIATE OLREORG** output fields and a description of each field:

### Short label

The short label that is generated in the XML output. This field does not apply to the **/INITIATE** command.

### Show Keyword

The command keyword that caused the field to be generated. N/A appears for output fields that are always returned.

### Meaning

A brief description of the output field.

*Table 346. Output fields for INITIATE OLREORG command*

| Short label | Show Keyword | Meaning   |
|-------------|--------------|---|
| PART        | N/A          | Partition name.   |
| MBR         | N/A          | The IMS that processed the command and built the command response line. |
| CC          | N/A          | Completion code.  |

## Return, reason, and completion codes

The OM return and reason codes that might be returned as a result of the **INITIATE OLREORG** command are standard for all commands that are entered through the OM API.

The following table includes the return and reason codes and a brief explanation of the codes. The return or reason code returned for the command might also indicate an error from a CSL request.

*Table 347. Return and reason codes for the INITIATE OLREORG command*

| Return code | Reason code | Meaning   |
|-------------|-------------|---|
| X'00000000' | X'00000000' | The <b>INITIATE OLREORG</b> command completed successfully.                       |
| X'00000004' | X'00001010' | No matches found for filter.  |
| X'00000008' | X'00002008' | Insufficient number of keywords.  |
| X'00000008' | X'00002020' | Invalid rate value.   |
| X'00000008' | X'00002040' | No filter, an invalid filter, or an insufficient number of filters was specified. |
| X'00000008' | X'00002133' | Multiple name parameters are invalid  |
| X'0000000C' | X'00003000' | At least one request was successful.  |

Table 347. Return and reason codes for the INITIATE OLREORG command (continued)

| Return code | Reason code | Meaning                                       |
|-------------|-------------|---|
| X'0000000C' | X'00003004' | None of the requests was successful.          |
| X'00000010' | X'0000400C' | Command issued on an XRF alternate.           |
| X'00000010' | X'00004030' | Command is invalid for LSO=Y.                 |
| X'00000010' | X'00004520' | Another HALDB alter operation is in progress. |
| X'00000014' | X'00005000' | A GETMAIN error occurred.                     |

The following table includes an explanation of the completion codes. Errors that are unique to the processing of **INITIATE OLREORG** command are returned as completion codes. A completion code is returned for each action against a HALDB partition. Also, if the type-1 **/INITIATE OLREORG** command is entered, the completion codes are displayed in the DFS0725I message.

Table 348. Completion codes for the INITIATE OLREORG command

| Completion code | Completion code text    | Meaning  |
|-----------------|-------------------------|--|
| 0               |                         | The <b>INITIATE OLREORG</b> command completed successfully for the partition.  |
| 10              |                         | Resource name is invalid.  |
| 14              |                         | Resource is not a partition name.  |
| 17              | ANOTHER CMD IN PROGRESS | The <b>INITIATE OLREORG</b> command failed because IMS was already processing another command that was issued against the same database. If OPTION(ALTER) was specified, the IMS system might be processing another <b>INITIATE OLREORG</b> command that has OPTION(ALTER) specified for the same or a different database. |
| 1C              |                         | Resource is a partitioned secondary index.   |
| 20              |                         | HALDB OLR is already in progress.  |
| 24              |                         | No OLR is in progress.   |
| 28              |                         | No DMB is loaded.  |
| 6C              |                         | Not allowed for a HALDB partition.   |
| 90              |                         | Internal error. The command entered is not processed because of an internal error.   |
| AE              |                         | Dynamic allocation error.  |
| C1              |                         | OLR database directory (DDIR) is missing.  |
| C3              |                         | OLR partition is either stopped or locked, or is in an input-only access state.  |
| C4              |                         | OLR partition is being recovered.  |
| C5              |                         | OLR partition access is not UPDATE or EXCLUSIVE.   |
| C6              |                         | OLR scheduling failed.   |
| C7              |                         | OLR partition is not authorized.   |

Table 348. Completion codes for the INITIATE OLREORG command (continued)

| Completion code | Completion code text            | Meaning   |
|-----------------|---------------------------------|---|
| C8              |                                 | OLR master database is either stopped or locked, or is in an input-only access state.   |
| C9              |                                 | OLR master database access is not UPDATE or EXCLUSIVE.  |
| CA              |                                 | OLR ownership setting failed.   |
| CC              | OLR IS ACTIVE FOR DATABASE      | The <b>INITIATE OLREORG</b> command failed because the OLR function, with or without OPTION(ALTER) specified, is already reorganizing one or more partitions in the database.   |
| CE              |                                 | HALDB OLR cannot access all the data in the partition because an EEQE exists.   |
| CF              |                                 | Parameter value conflict, or invalid parameter value.   |
| DA              |                                 | The command processing failed because the database is being recalled from HSM.  |
| DF              | DB DIRECTORY INIT FAILURE       | The DDIR for the database cannot be initialized.  |
| E7              |                                 | The database command could not be processed because a command that specifies START(QUIESCE) is in progress.   |
| 120             |                                 | Staging ACBLIB empty.   |
| 122             |                                 | Not all PSBS rebuilt for this DMB.  |
| 1E1             | OLR ITASK creation failed       | An internal OLR ITASK cannot be created.  |
| 1E2             | RECON MINVERS or CHANGE# error  | In the RECON data set, either the minimum IMS version that is specified in the RECON data set does not support OPTION(ALTER), or the change version number in a CHANGE# field does not match the change version number in the database directory (DDIR) control block for the HALDB database. The minimum IMS version is specified in the RECON by the MINVERS keyword on either the INIT.RECON or the CHANGE.RECON DBRC command. |
| 1E3             | Partition queued for OLR        | The partition is queued for online reorganization processing by either the OLR function or the OLR function with the ALTER option specified.  |
| 1E4             | OLC is pending for HALDB alter  | An alter request against the same HALDB was done, but an Online Change has not yet done for the HALDB.  |
| 1E5             | No DB structure change detected | OPTION(ALTER) was specified, but the ACB member for the specified HALDB database does not contain any structural changes.<br><br>If you intended to change the structure of the database, ensure that the ACB member that contains the database changes is in the ACB staging library. If you are not changing the structure of the database, remove the OPTION(ALTER) keyword from the command.                                  |



Table 348. Completion codes for the INITIATE OLREORG command (continued)

| Completion code | Completion code text                | Meaning   |
|-----------------|-------------------------------------|---|
| 1E6             | Insufficient CI/Block size detected | The size of the block or CI of an output data set is too small.<br><br>Before initiating the alter operation, increase the size of the block or CI by issuing the DBRC CHANGE.PART command.               |
| 1E7             | Unsupported DBD changes detected    | The ACB member for the specified database contains a structural change that is not supported by the ALTER option.<br><br>See message DFS1849E for the reason code that identifies the unsupported change. |
| 1E8             | Altered DMB not loaded              | The DMB for the altered database was not loaded, so the delta block required to validate the structural changes to the database could not be created.   |
| 1E9             | DB level error detected             | During alter processing, a database level error on the altered DBD is detected.   |
| 1EA             | Segment level error detected        | During alter processing, a segment level error on the altered DBD is detected.  |
| 1EB             | Field level error detected          | During alter processing, a field level error on the altered DBD is detected.  |
| 1EC             | Logical database error              | During alter processing, an error related to a logical relationship on the altered DBD is detected.   |
| 1ED             | HALDB structure not init            | Required internal HALDB control blocks were not initialized or accessible.  |
| 1EE             | Alter owned by other IMS            | Alter processing could not be resumed on this IMS system because all partitions that remain to be altered are owned by one or more other IMS systems.   |
| 1EF             | Not OLR capable                     | The database is not capable of being reorganized online, which can be caused by a HALDB database that uses 8-GB OSAM data sets.   |
| 235             | EMPTY STAGING DIRECTORY             | During processing of the INITIATE OLREORG command, the ACB member that contains the altered database definition was not found in the staging ACB library.   |

### Examples

The following are examples of the **INITIATE OLREORG** command.

#### **Example 1 for /INITIATE OLREORG command**

Entry ET:

```
/INITIATE OLREORG NAME(HALDBPRT) SET(RATE(50))
```

Response ET:

```
DFS058I INITIATE COMMAND IN PROGRESS  
DFS0725I INITIATE OLREORG COMMAND FOR DB HALDBPRT COMPLETE. CC=0
```

System Console or MTO:

```
DFS2970I - OLR STARTED FOR NAME=HALDBPRT  
DFS0725I INITIATE OLREORG COMMAND FOR DB HALDBPRT COMPLETE. CC= 0
```

Explanation: The **/INITIATE OLREORG** command for the partition named HALDBPRT is issued from a terminal, resulting in the message, DFS058I INITIATE COMMAND IN PROGRESS being sent to that entering terminal. When OLR is started successfully, the DFS0725I and DFS2970I messages are sent to the system console and to the MTO. The DFS0725I message is also sent to the entering terminal if the entering terminal is not the system console, MTO, AOI program.

### **Example 2 for /INITIATE OLREORG command**

Entry ET:

```
/INIT OLREORG NAME(PDHDOKA) SET(RATE(5))
```

Response ET:

```
DFS058I INITIATE COMMAND IN PROGRESS  
DFS0725I INITIATE OLREORG COMMAND FOR DB PDHDOKA COMPLETE. CC=0
```

Response MTO or System console:

```
DFS2970I - OLR STARTED FOR NAME=PDHDOKA  
DFS0725I INITIATE OLREORG COMMAND FOR DB PDHDOKA COMPLETE. CC=0
```

Explanation: The **INIT OLREORG** command for the partition named PDHDOKA is issued from a terminal, resulting in the DFS058I INITIATE COMMAND IN PROGRESS message being sent to that entering terminal. The DFS0725I message is also sent to the entering terminal if the entering terminal is not the system console, the MTO, or an AOI program.

When OLR is started successfully, the DFS0725I and the DFS2970 messages are sent to the system console and to the MTO.

### **Example 3 for INITIATE OLREORG command**

TSO SPOC Input:

```
INIT OLREORG NAME(PDHDOKA,PDHDOKB) SET(RATE(5))
```

TSO SPOC output:

| Partition | MbrName | CC |
|-----------|---------|----|
| PDHDOKA   | IMSA    | 0  |
| PDHDOKA   | IMS1    | C3 |
| PDHDOKB   | IMSA    | 0  |
| PDHDOKB   | IMS1    | C3 |

OM API Input:

```
CMD (INIT OLREORG NAME(PDHDOKA,PDHDOKB) SET(RATE(5)))
```

OM API output:

```
<imsout>  
<ctl>  
<omname>OM10M </omname>  
<omvsn>1.2.0</omvsn>  
<xmlvsn>1 </xmlvsn>  
<statime>2003.168 21:19:06.827362</statime>  
<stotime>2003.168 21:19:07.036292</stotime>  
<staseq>B99629BFEC66256E</staseq>  
<stoseq>B99629C01F684F44</stoseq>  
<rqsttkn1>USRT005 10141906</rqsttkn1>  
<rc>00000000</rc>  
<rsn>00000000</rsn>  
</ctl>
```

```

<cmd>
<master>IMSA      </master>
<userid>USRT005 </userid>
<verb>INIT</verb>
<kwd>OLREORG      </kwd>
<input>INIT OLREORG NAME(PDHDOKA,PDHDOKB) SET(RATE(5)) </input>
</cmd>
<cmdsphdr>
<hdr slbl="PART" llbl="Partition" scope="LCL" sort="A" key="1"
  scroll="NO" len="9" dtype="CHAR" align="left" />
<hdr slbl="MBR" llbl="MbrName" scope="LCL" sort="N" key="0" scroll="NO"
  len="8" dtype="CHAR" align="left" />
<hdr slbl="CC" llbl="CC" scope="LCL" sort="N" key="0" scroll="YES"
  len="4" dtype="INT" align="right" />
</cmdsphdr>
<cmdsdata><rsp> PART(PDHDOKA ) MBR(IMSA      ) CC(      0) </rsp>
<rsp> PART(PDHDOKB ) MBR(IMSA      ) CC(      0) </rsp>
<rsp> PART(PDHDOKA ) MBR(IMS1      ) CC(      C3) </rsp>
<rsp> PART(PDHDOKB ) MBR(IMS1      ) CC(      C3) </rsp>
</cmdsdata>
</imsout>

```

Explanation: The **INIT OLREORG** command is issued from TSO SPOC for partitions PDHDOKA and PDHDOKB. The command is routed to IMSA and IMS1. The command is successful at IMSA for both partitions, but is not successful at IMS1 for both partitions.

#### **Example 4: INITIATE OLREORG command with OPTION(ALTER)**

In the following example, the **INITIATE OLREORG** command with the ALTER option is issued for the HALDB database DBOVLFC, which contains four partitions.

Two IMS systems are participating in the alter operation, IMS1 and IMS2. IMS1 gets ownership of partitions PDBOVL A and PDBOVL C. IMS2 gets ownership of PDBOVL B and PDBOVL D.

When alter processing stops in an IMS system, the IMS system issues message DFS3198I.

TSO SPOC Input:

```
INIT OLREORG OPTION(NODEL,ALTER,NOREL) SET(RATE(100)) NAME(DBOVLFC)
```

TSO SPOC output:

| Partition | MbrName | CC |
|-----------|---------|----|
| PDBOVL A  | IMS2    | CA |
| PDBOVL A  | IMS1    | 0  |
| PDBOVL B  | IMS2    | 0  |
| PDBOVL B  | IMS1    | CA |
| PDBOVL C  | IMS2    | CA |
| PDBOVL C  | IMS1    | 0  |
| PDBOVL D  | IMS2    | 0  |
| PDBOVL D  | IMS1    | CA |

OM API Input:

```
CMD (INIT OLREORG OPTION(NODEL,ALTER,NOREL) SET(RATE(100)) NAME(DBOVLFC))
```

OM API output:

```

<statime>2013.217 22:36:48.063386</statime>
<stotime>2013.217 22:36:50.823178</stotime>
<staseq>CBC4B3A59D79A7C2</staseq>
<stoseq>CBC4B3A83F40A950</stoseq>
<rqsttkn1>USRT011 10153648</rqsttkn1>
[...]
<cmd>
<master>IMS2      </master>
<userid>USRT011 </userid>
<verb>INIT</verb>
<kwd>OLREORG      </kwd>
<input>INIT OLREORG OPTION(NODEL,ALTER,NOREL) SET(RATE(100))
  NAME(DBOVLFC) </input>
</cmd>
<cmdsphdr>
<hdr slbl="PART" llbl="Partition" scope="LCL" sort="A" key="1"
  scroll="NO" len="7" dtype="CHAR" align="left" />

```

```

<hdr s1b1="MBR" l1b1="MbrName" scope="LCL" sort="N" key="0" scroll="NO"
  len="8" dtype="CHAR" align="left" />
<hdr s1b1="CC" l1b1="CC" scope="LCL" sort="N" key="0" scroll="YES"
  len="4" dtype="INT" align="right" />
</cmdrpsphdr>
<cmdrpspdata>
<rsp> PART(PDBOVL A ) MBR(IMS2 ) CC( CA ) </rsp>
<rsp> PART(PDBOVL B ) MBR(IMS2 ) CC( 0 ) </rsp>
<rsp> PART(PDBOVL C ) MBR(IMS2 ) CC( CA ) </rsp>
<rsp> PART(PDBOVL D ) MBR(IMS2 ) CC( 0 ) </rsp>
<rsp> PART(PDBOVL A ) MBR(IMS1 ) CC( 0 ) </rsp>
<rsp> PART(PDBOVL B ) MBR(IMS1 ) CC( CA ) </rsp>
<rsp> PART(PDBOVL C ) MBR(IMS1 ) CC( 0 ) </rsp>
<rsp> PART(PDBOVL D ) MBR(IMS1 ) CC( CA ) </rsp>
</cmdrpspdata>

```

Each IMS system issues DFS3198I when alter processing stops. The message shows the number of partitions in the database, the number of partitions that the IMS system started altering, and the number of partitions that the IMS system successfully altered.

```

DFS3198I HALDB ALTER ENDED FOR NAME=DBOVLFPD
PARTITION NUMBER=4     STARTED=2     COMPLETED=2     IMS1

DFS3198I HALDB ALTER ENDED FOR NAME=DBOVLFPD
PARTITION NUMBER=4     STARTED=2     COMPLETED=2     IMS2

```

### Related concepts

[How to interpret CSL request return and reason codes \(System Programming APIs\)](#)

### Related reference

[“Command keywords and their synonyms” on page 59](#)

All IMS command keywords and their synonyms, as well as keywords supported by the OM API, are listed. The list covers command keywords for the OM command processing clients such as IMS, ODBM, IMSCON, and RM.

---

## Chapter 38. /LOCK command

The **/LOCK** command stops the sending and receiving of messages to and from a terminal, stops the scheduling of messages containing a specific transaction code, stops the scheduling of a specific program, and stops the use of a database.

Queuing of output messages for a particular communication line, terminal, or transaction code is not affected.

Subsections:

- [“Environment” on page 889](#)
- [“Syntax” on page 889](#)
- [“Keywords” on page 890](#)
- [“Usage notes” on page 891](#)
- [“Equivalent IMS type-2 commands” on page 892](#)
- [“Examples” on page 892](#)

### Environment

The following table lists the environments (DB/DC, DBCTL, and DCCTL) in which you can use the command and keywords.

*Table 349. Valid environments for the /LOCK command and keywords*

| Command / Keywords | DB/DC | DBCTL | DCCTL |
|--------------------|-------|-------|-------|
| <b>/LOCK</b>       | X     | X     | X     |
| DB                 | X     | X     |       |
| LTERM              | X     |       | X     |
| NODE               | X     |       | X     |
| PGM                | X     | X     | X     |
| PTERM              | X     |       | X     |
| TRAN               | X     |       | X     |

### Syntax

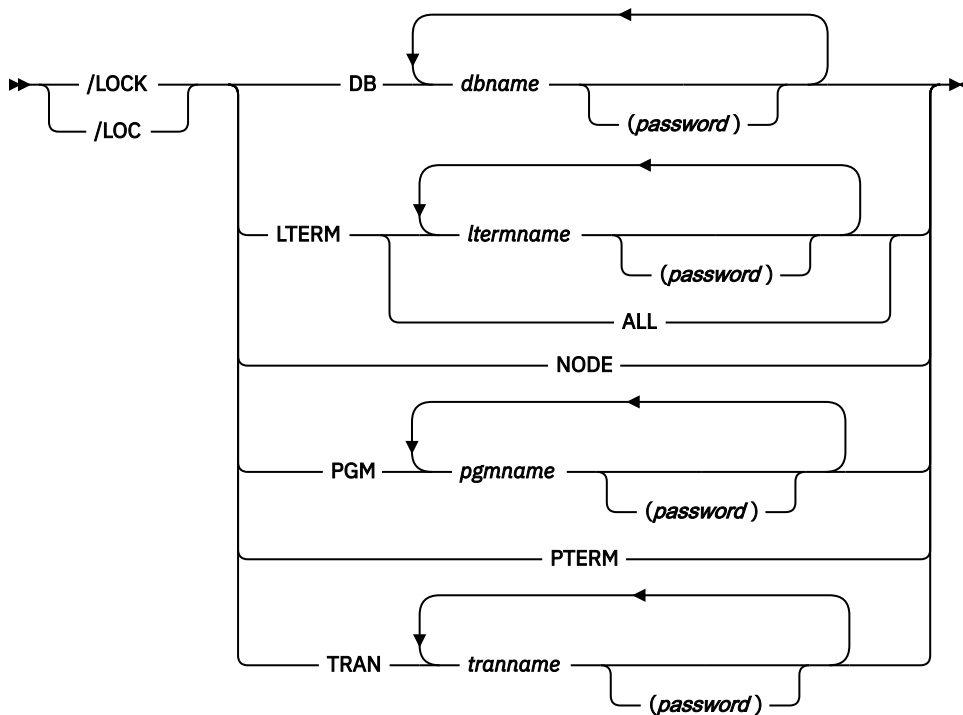

## Keywords

The following keywords are valid for the `/LOCK` command:

### DB

**LOCK** prevents subsequently scheduled programs from accessing the database. The `/LOCK DB` command does not close the database or affect currently scheduled programs.

If the database is a DEDB or MSDB, programs using the database will not be scheduled. For other databases, the programs will still be scheduled. If the INIT call was issued, however, a call against the database will result in either a 3303 pseudoabend or a BA status code.

For DBCTL, CCTL can specify LONG or SHORT when it schedules a PSB. If the database is currently scheduled to a LONG thread, the command is rejected. If not, the thread completes before the database is acted upon. If the thread completes, a commit point or transaction termination is the result.

While the database is being quiesced, this command cannot be processed successfully.

### LTERM

Specifies the logical terminal for which sending and receiving of messages is to be stopped. `/LOCK LTERM` applies only to logical terminals associated with the entering physical terminal.

The `/LOCK LTERM ALL` command can only be used when none of the logical terminals associated with the entering physical terminal have passwords.

### NODE

Specifies that the sending and receiving of messages for the VTAM node associated with the entering physical terminal is to be stopped.

### PGM

Specifies the program for which scheduling is to be stopped.

### PTERM

Specifies that the sending and receiving of messages for the entering physical terminal is to be stopped.

## TRAN

Specifies that scheduling of messages containing this transaction code is to be stopped. The **/LOCK TRAN** command cannot be used with Fast Path exclusive transactions but can be used with Fast Path potential transactions.

The **/LOCK TRAN** command cannot be used for CPI Communications driven programs.

## Usage notes

The **/LOCK** command can be used on HALDB databases.

The output of the **/LOCK DB** command is changed when the command is entered through the OM API. In this case, the DFS058I message is not returned to OM. The command response returned to OM contains one or more of the following messages: DFS0488I, DFS3466I, or DFS132. The OM API does not support the **/LOCK** command without any keywords.

The **/LOCK** command can be issued by APPC and OTMA clients.

This command can be issued to an IMSplex by using the Batch SPOC utility.

A resource name can be defined with password protection in SAF for the DB, LTERM, PGM, and TRAN keywords. If the parameter, LOCKSEC=Y (N is the default) is specified on the DFSPBxxx IMS.PROCLIB member, IMS calls the SAF and user exit calls. If the resource is not defined to SAF, or is defined and is authorized to the user, the command is processed. If the resource is defined to SAF but not authorized for use, the command is rejected with a DFS3689W message.

The password associated with a signed on user, and specified after a command resource parameter, will be used to perform a reverification check, if the resource is defined to RACF with 'REVERIFY' specified in the APPLDATA field. Passwords can be mixed case or uppercase depending on what is specified on the PSWDC keyword in the DFSPBxxx IMS.PROCLIB member. If the resource passes the RACF authorization check, and RVFY=Y is specified as an IMS startup parameter, IMS will verify that the password following the parameter is the same as the password entered during signon for the user that entered the command. If 'REVERIFY' is specified for a resource, but a password is not provided, or the wrong password is provided, the command processing for that resource will be rejected.

A period that is specified in the password brackets is not treated as a delimiter.

The **/LOCK LTERM**, **NODE**, and **PTERM** commands apply only to the entering physical terminal. The **/LOCK DB | PGM | TRAN** command is only valid if entered from the master terminal, the system console, a TCO script, or an AOI application program.

Issuing the **/LOCK** command for a physical terminal, logical terminals, or nodes prevents application program output from being sent (assuming nonresponse mode transactions) and message switches from any other terminals. Output message queuing continues for the locked physical terminal. The **/STOP LTERM** command can be used instead of the **/LOCK LTERM** command, because both stop the sending and receiving of messages to the physical terminal.

If the terminals are on a switched communication network and a physical or logical terminal disconnection occurs, an implied **/UNLOCK** command is processed against the physical terminal and inquiry logical terminal.

The **/LOCK** command cannot be used with logical terminals assigned to deallocated users.

When you enter this command, the database name can be an existing non-HALDB, a HALDB master, or a HALDB partition. A command against a HALDB partition operates exactly like a command against a non-HALDB with the exception of the **/START DB** and the **UPDATE DB START(ACCESS)** commands. A HALDB partition is not allocated during the command unless it was previously authorized but not allocated, the OPEN keyword was specified, or the partition has EEQEs. The partition is allocated at first reference.

The HALDB partition reflects conditions such as STOPPED, LOCKED, or NOTOPEN. When a HALDB partition is stopped, it must be explicitly started again. Commands with the keyword ALL and commands against a HALDB master do not change the STOPPED and LOCKED indicators in each HALDB partition.

When the command target is a HALDB master, processing acts on all HALDB partitions. For example, if the IMS command is **/DBR** on the HALDB master, all of the HALDB partitions are closed, deallocated, and deauthorized. Only the HALDB master displays STOPPED (each HALDB partition does not display STOPPED unless it was itself stopped). If a **/DBR** command was issued against a HALDB master, the display output of a **/DISPLAY DB** command shows the HALDB master (as STOPPED), but does not display the status of the partitions.

Each partition inherits the access limitations of its HALDB master. If the **/DBD** command is issued against a HALDB master, all of its partitions close. A subsequent reference to any of the partitions results in the partition opening for input, although the partition's access might be UPDATE or EXCLUSIVE. The DBRC authorization state reflects the limited access.

## Equivalent IMS type-2 commands

The following table shows variations of the **/LOCK** command and the IMS type-2 commands that perform similar functions.

Table 350. Type-2 equivalents for the **/LOCK** command

| Task                         | <b>/LOCK</b> command              | Similar IMS type-2 command                           |
|------------------------------|-----------------------------------|--|
| Stops the use of a database. | <b>/LOCK</b> DB <i>dbname</i>     | UPDATE DB NAME( <i>dbname</i> )<br>SET(LOCK(ON))     |
| Locks a program.             | <b>/LOCK</b> PGM <i>pgmname</i>   | UPDATE PGM NAME( <i>pgmname</i> )<br>SET(LOCK(ON))   |
| Locks a transaction.         | <b>/LOCK</b> TRAN <i>tranname</i> | UPDATE TRAN NAME( <i>tranname</i> )<br>SET(LOCK(ON)) |

### Examples

The following are examples of the **/LOCK** command:

#### Example 1 for **/LOCK** command

Entry ET:

```
/LOCK DB TREEFARM
```

Response ET:

```
DFS058I LOCK COMMAND COMPLETED
```

Explanation: Application programs that use the MSDB database named TREEFARM are no longer scheduled. Transaction input can continue.

#### Example 2 for **/LOCK** command

Entry ET:

```
/LOCK LTERM ALL
```

Response ET:

```
DFS058I LOCK COMMAND COMPLETED
```

Explanation: Output is queued but not sent to the logical terminals associated with the physical terminal from which the **/LOCK** command was entered.

#### Example 3 for **/LOCK** command



Entry ET:

```
/LOCK PGM APPLETRE
```

Response ET:

```
DFS058I LOCK COMMAND COMPLETED
```

Explanation: Program APPLETRE can no longer be scheduled.

#### ***Example 4 for /LOCK command***

Entry ET:

```
/LOCK PTERM
```

Response ET:

```
DFS058I LOCK COMMAND COMPLETED
```

Explanation: Application program output (if nonresponse mode transaction) and message switches from other terminals are not sent to the entering physical terminal. Output is queued for later transmission when the terminal is unlocked.

#### ***Example 5 for /LOCK command***

Entry ET:

```
/LOCK TRAN SEED
```

Response ET:

```
DFS058I LOCK COMMAND COMPLETED
```

Explanation: The application program for transaction code SEED can no longer be scheduled. Transaction input can continue.

Entry ET:

```
/LOCK TRAN TXCDLM06
```

Response ET:

```
DFS058I LOCK COMMAND COMPLETED EXCEPT TRANSACTION  
TXCDLM06
```

Explanation: TXCDLM06 is a Fast Path exclusive transaction. The **/LOCK** command cannot stop the scheduling of Fast Path exclusive transactions.

#### **Related concepts**

[Sharing secondary index databases \(Database Administration\)](#)

#### **Related reference**

[UPDATE DB command \(Commands\)](#)

[UPDATE PGM command \(Commands\)](#)

[UPDATE TRAN command \(Commands\)](#)



## Chapter 39. /LOG command

The **/LOG** command writes a single-segment message to the IMS system log. Any text can be logged, including transaction codes or command streams.

Subsections:

- [“Environment” on page 895](#)
- [“Syntax” on page 895](#)
- [“Keywords” on page 895](#)
- [“Usage notes” on page 895](#)
- [“Example” on page 895](#)

### Environment

The following table lists the environments (DB/DC, DBCTL, and DCCTL) from which the command can be issued.

Table 351. Valid environments for the /LOG command

| Command | DB/DC | DBCTL | DCCTL |
|---------|-------|-------|-------|
| /LOG    | X     | X     | X     |

### Syntax

►► /LOG — *text* ◄◄

### Keywords

The following keywords are valid for the **/LOG** command:

#### *text*

An alphanumeric character message to be logged.

### Usage notes

An X'02' log record is produced and contains the text. This command applies only to the currently entered message segment and does not establish a continuing operational mode.

This command can be issued to an IMSplex using the Batch SPOC utility.

### Example

Entry ET:

```
/LOG TODAY IS MONDAY
```

Response ET:

```
DFS058I LOG COMMAND COMPLETED
```

Explanation: An X'02' log record containing the text

```
TODAY IS MONDAY
```

is written to the IMS system log.

## Chapter 40. /LOOPTEST command

The **/LOOPTEST** command is a multisegment command that creates an output write loop that tests for output errors.

It causes a single-segment message to be repeatedly transmitted to the terminal being tested.

Subsections:

- [“Environment” on page 897](#)
- [“Syntax” on page 897](#)
- [“Usage notes” on page 897](#)
- [“Example” on page 898](#)

### Environment

The following table lists the environments (DB/DC, DBCTL, and DCCTL) in which you can use the command and keywords.

Table 352. Valid environments for the /LOOPTEST command and keywords

| Command / Keywords | DB/DC | DBCTL | DCCTL |
|--------------------|-------|-------|-------|
| <b>/LOOPTEST</b>   | X     |       | X     |
| LINE               | X     |       | X     |
| PTERM              | X     |       | X     |

### Syntax

▶ **/LOOPTEST** **LINE** *line#* **PTERM** *pterm#* ▶  
    **/LOO**

### Usage notes

Multisegment input is combined into a single segment for output transmission. For the terminal in looptest mode to receive the complete message, the cumulative output segment must not exceed the terminal's output size restrictions.

**/LOOPTEST** requires an EOM indication to denote end-of-message; an EOS indication must be included for all segments that precede the last segment.

**/LOOPTEST** causes all I/O error detection and notification procedures within IMS to be bypassed. Depending on the types of errors involved, some write loops might result in high processor utilization.

The **/END** command terminates looptest mode.

#### LINE, PTERM

Specifies the communication line or physical terminal to be placed into looptest mode. If the terminal in looptest mode is attached to a multipoint line, the entire line must be stopped and idle before the **/LOOPTEST** command is allowed. **/LOOPTEST** is not allowed on VTAM-attached terminals.

If the device specified is not powered on and ready, intervention-required messages will be sent to the master terminal.

The **/DISPLAY LINE PTERM** command identifies a terminal in looptest mode.

### Example

Entry ET:

```
/LOOPTEST LINE 5 PTERM 1 (EOS)  
DATA TEST (EOS)  
12345 (EOM)
```

Response ET:

```
DFS058I LOOPTEST COMMAND COMPLETED
```

Response RT:

```
DATA TEST 12345  
DATA TEST 12345  
and so forth.
```

Explanation: DATA TEST 12345 is repetitively sent to PTERM 1 on LINE 5.

### Related reference

[“How to enter IMS commands” on page 2](#)

These topics describe how to enter various types of IMS commands.

# Chapter 41. /MODIFY command

The **/MODIFY** command controls the modification of IMS resources online.

It switches the online environment from the active ACBLIB, FORMAT, and MODBLKS libraries to the inactive libraries containing the new or changed resource descriptions.

Subsections:

- [“Environment” on page 899](#)
- [“Syntax” on page 899](#)
- [“Keywords” on page 900](#)
- [“Usage notes” on page 902](#)
- [“Examples” on page 903](#)

## Environment

The following table lists the environments (DB/DC, DBCTL, and DCCTL) in which you can use the command and keywords.

Table 353. Valid environments for the /MODIFY command and keywords

| Command / Keywords | DB/DC | DBCTL | DCCTL |
|--------------------|-------|-------|-------|
| <b>/MODIFY</b>     | X     | X     | X     |
| ABORT              | X     | X     | X     |
| COMMIT             | X     | X     | X     |
| LTERM              | X     |       | X     |
| PREPARE            | X     | X     | X     |

## Syntax

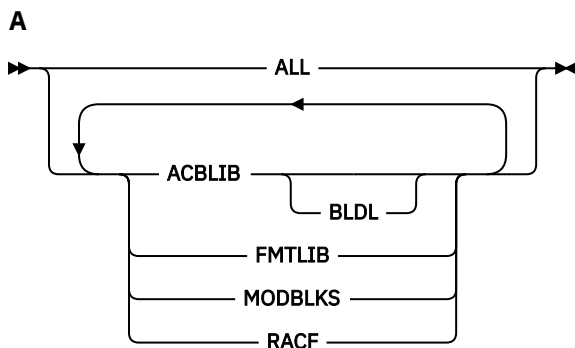
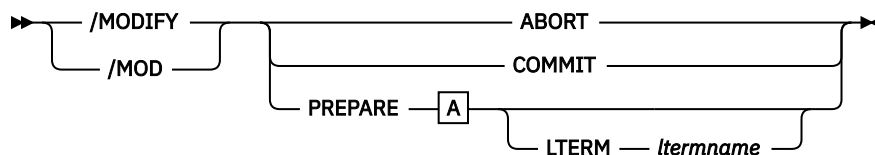

## Keywords

The following keywords are valid for the **/MODIFY** command:

### ABORT

Resets the status that was set by the **/MODIFY PREPARE** command after a **/MODIFY PREPARE**, or can be used if the **/MODIFY COMMIT** was not successful and the operator chooses not to attempt the online change at that time.

### COMMIT

Brings all the newly defined resources online, updates the changed resources, and invalidates the deleted resources.

If ALL was specified on the **/MODIFY PREPARE** command, the ACBLIB, FMTLIB, and MODBLKS changes must be successful or the **/MODIFY COMMIT** will be rejected. When COMMIT is successful, the modifications will persist across all IMS restarts. If FMTLIB is entered, most new and in-progress requests will be queued for processing after the **/MODIFY COMMIT** command is completed.

If MODBLKS or ACBLIB is specified, work in progress for changed or deleted resources in the IMS.ACBLIB data set or in the IMS.MODBLKS data set that are directly affected must be completed, or the **/MODIFY** command is rejected.

If DRD is enabled and **/MODIFY PREPARE ALL** was specified, the **/MODIFY COMMIT** command does not swap the MODBLKS library suffix. The DFS3499 message shows the same MODBLKS suffix before and after the online change.

IMS does not reject the **/MODIFY COMMIT** command if the online change indirectly affects transactions (having work in progress) that reference resources in the ACB library or in the MODBLKS data set that are directly affected by the online change. These transactions themselves are not being changed (no attribute on the TRANSACT macro is being changed), but they reference a PDIR, PSB, or DMB that is affected by the online change. A transaction can be indirectly affected by an online change in one of the following situations:

- The transaction references a PSB directory (PDIR) control block in the IMS.MODBLKS data set that is being changed
- The transaction references a PSB in the ACB library (IMS.ACBLIB) that is being changed online
- The transaction references a PSB directory (PDIR) control block in the IMS.MODBLKS data set which in turn references a database that is being changed online
- The transaction references a PSB in the ACB library (IMS.ACBLIB) that references a database that is being changed online

**/DISPLAY MODIFY** is used to display the work that was in progress prior to the entering of **/MODIFY COMMIT**.

IMS will prevent messages entered from terminals from being queued to transactions, but program-to-program switches from applications can still occur. Therefore, a **/DISPLAY MODIFY** command can indicate that no work is pending for the resources to be modified or deleted, but the **/MODIFY COMMIT** might be rejected. If this occurs, the new work must be allowed to complete and then the **/MODIFY COMMIT** command must be reentered.

**/MODIFY COMMIT** is rejected if:

- A **/MODIFY PREPARE** command was not previously entered.
- Transactions to be deleted have messages queued.
- Transactions to be changed by the following system definition keywords have messages queued:
  - MSGTYPE
  - INQUIRY
  - FPATH
  - EDIT



– SPA

- Transactions to be changed by keywords not shown in the previous bullet have messages queued, and the transactions have not been the object of a **/STOP** or **/PSTOP** command.
- Transactions with access to programs or databases to be changed or deleted are prevented from updating, and the transactions have not been the object of a **/STOP** or **/PSTOP** command. When a transaction shows a status of USTOP during a **/DISPLAY TRAN**, the **/STOP** command might need to be entered, because the **/PSTOP** command might not enable the **/MODIFY** command to complete the transaction.
- Any program (PSB) that is currently scheduled has a program, database, or transaction change or deletion. This includes Wait for Input (WFI) and Fast Path transactions. All WFI and Fast Path regions that reference changed or deleted routing codes, programs, or databases must be stopped before entering the **/MODIFY COMMIT**.
- An I/O error occurs while reading the inactive MFS FORMAT library directory or the resident index (\$\$IMSDIR) member.
- A **/START DATABASE** command is in progress for any database that is changed or deleted.
- A **/DBDUMP** or **/DBRECOVERY** command is in progress for any database that is changed or deleted.

Operator action might be required to prevent the preceding conditions. For example, if a program or database is scheduled, the operator should either wait until the program or database is finished before the **/MODIFY COMMIT** command is entered, or the operator should issue **/STOP** or **/PSTOP** for the associated transaction.

If IMS is in an IMSplex and Resource Manager (RM) is using a resource structure, the transactions being added by the online change are registered to RM if they are not already registered to RM. If any error occurs during the CSLRMUPD request to register the transactions, the **/MODIFY** or **INITIATE OLC** command will fail and IMS will be in a COMMIT2F state.

If a **/MODIFY COMMIT** command results in the COMMIT2F state, the command is rejected with a DFS178 message. A DFS3308 message is sent to the system console with the CSLRMUPD return/reason code. The IMS remains in a COMMIT2F state and the **/MODIFY** cannot be committed or aborted. The IMS must be canceled and warm started as the online change is not complete.

## PREPARE

**/MODIFY PREPARE** is not recovered across an emergency restart and must be reentered after restart if the **/MODIFY COMMIT** did not complete prior to an IMS failure.

The parameters in the following table are valid with **/MODIFY PREPARE**. The environments in which the parameters are valid are also shown in this table.

Table 354. **/MODIFY PREPARE** parameters environments

| Parameter | DB/DC | DBCTL                      | DCCTL |
|-----------|-------|----------------------------|-------|
| ACBLIB    | X     | X                          | X     |
| ALL       | X     | X <sup>1</sup> on page 901 | X     |
| BLDL      | X     | X                          | X     |
| FMTLIB    | X     |                            | X     |
| LTERM     | X     |                            | X     |
| MODBLKS   | X     | X                          | X     |
| RACF      | X     |                            | X     |

### Note:

1. Only applies to ACBLIB, MODBLKS, and BLDL.

## **ACBLIB**

Quiesces the transactions to be changed or deleted and transactions that access databases or programs to be changed or deleted. ACBLIB members that are not found are displayed as CHANGED because a DDIR or PDIR exists in MODBLKS. Additions or deletions to ACBLIB require the MODBLKS parameter.

If a DMB is being added to the ACBLIB with no MODBLKS change (no DMB exists in the active ACBLIB and a DMB exists in the inactive ACBLIB), then the display will show ADDED instead of CHANGED. If a DMB is being deleted from the ACBLIB with no MODBLKS change (DMB exists in the active ACBLIB and no DMB exists in the inactive ACBLIB), then the display will show DELETED instead of CHANGED. No MODBLKS change means a DDIR exists in the MODBLKS and the same MODBLKS is used before and after the online change.

The /MODIFY command is rejected if it is issued with the ACBLIB keyword on an IMS system in which the IMS management of ACBs is enabled. IMS systems that manage ACBs do not use an ACB library.

## **ALL**

Indicates that **/MODIFY PREPARE** is to be performed for ACBLIB, FMTLIB, RACF, MODBLKS and BLDL.

If the ALL keyword is specified when both dynamic resource definition (DRD) and the IMS management of ACBs are enabled, the IMS system rejects the /MODIFY command.

ACBLIB is ignored if IMS management of ACBs is enabled.

MODBLKS is ignored if DRD is enabled.

FMTLIB is ignored in a DBCTL system.

In a DBCTL IMS with IMS management of ACBs and DRD enabled the command with **ALL** is rejected.

## **BLDL**

Causes information message DFS3498I to be issued for each PSB or DMB not found in ACBLIB. This message does not affect the success of the command.

## **FMTLIB**

Indicates that there will be no restrictions on the use of MFS format blocks until the **/MODIFY COMMIT** command is entered.

## **LTERM *ltermname***

Specifies a logical terminal to receive lists of added, changed, or deleted resources.

## **MODBLKS**

Causes IMS to prepare to bring the changes or deletions defined by the new system definition to IMS. Using MODBLKS also quiesces the transactions to be changed or deleted and transactions that access databases or programs to be changed or deleted. This command is rejected if it is issued on an IMS that has DRD enabled.

## **RACF**

Use of the RACF data space invalidates the IMS online change support for RACF with the **/MODIFY** command. The IMS online change support is still valid, though, when the RACF data space is not being used.

The message DFS3432 RACF PARAMETER INVALID IF RACF DATA SPACE IS USED is issued if the RACF parameter is used on the **/MODIFY PREPARE** command when the RACF data space is being used. You can use the RACF command **SETROPTS RACLIST (classname) REFRESH** to refresh the RACF resource profiles in the RACF data space without requiring the IMS applications to suspend work.

## **Usage notes**

The following table lists the resources and parameters available to the **/MODIFY** command:

Table 355. Resources and parameters available to the /MODIFY command

| Parameter | Library                                      | Description   |
|-----------|--|---|
| ACBLIB    | IMS.ACBLIBx <a href="#">“1” on page 903</a>  | Contains database and program descriptors such as DMBs and PSBs.  |
| FMTLIB    | IMS.FORMATx <a href="#">“1” on page 903</a>  | Contains MFS maps produced by the MFS language utility and service utility. The FMTLIB parameter is not valid with DBCTL. |
| MODBLKS   | IMS.MODBLKSx <a href="#">“1” on page 903</a> | Contains a subset of control blocks produced by IMS system definition.  |
| RACF      |  | RACF in-storage profiles. The RACF parameter is not valid with DBCTL.   |

**Note:**

1. x = A or B
2. Use the **SETROPTS RACLIST(CIMS) REFRESH** command to refresh RACF updates.

The correct sequence for /MODIFY commands is PREPARE followed by COMMIT. If the online change is not to be completed, the /MODIFY ABORT command is used. The /MODIFY PREPARE command specifies which resources are to be changed or deleted. Depending on the parameters entered, the system will initiate quiescing of appropriate resources. COMMIT initiates the changes entered in a preceding PREPARE. If a previously entered /MODIFY PREPARE command is to be canceled, ABORT must be entered.

An IMS automated operator program can issue the /MODIFY PREPARE and /MODIFY ABORT commands, but it cannot issue the /MODIFY COMMIT command. Thus, you can automatically prepare or abort online change.

If this command is used to delete a database, IMS closes the database and makes it unavailable to programs. Also, if the database is authorized for DBRC, /MODIFY deauthorizes it.

Fast Path DEDBs are supported by the /MODIFY command, but Fast Path MSDBs are not supported.

In an IMSplex, /MODIFY is not supported if coordinated online change is enabled. This command can be issued to an IMSplex using the Batch SPOC utility.

If DRD is enabled, the /MODIFY command specified with the MODBLKS keyword alone or with other keywords is rejected. The command /MODIFY PREPARE ALL ignores resources in the MODBLKS data set. If IMS is started without the MODBLKS DD cards, the MODBLKS-name field in the DFS3499 message is blank, which means that the MODBLKS data set is not applicable. This is consistent with what DBCTL does with FMTLIB. If IMS is started with the MODBLKS DD statements, the MODBLKS-name field is displayed, with a name suffix of A during prepare and during commit, which means that the MODBLKS libraries were not changed. The ACBLIB and FMTLIB data sets are still supported if DRD is enabled.

An online change of a PSB or DBD will remove the member from the 31-bit pool as well as the 64-bit pool.

If a resident program is changed, it becomes nonresident locally because its definition in the resident PSB pool is no longer valid. If its resident definition attribute was not changed, it becomes resident again at the next IMS restart. If a nonresident program is changed to be resident, the residency takes effect at the next IMS restart.

**Examples**

The following are examples of the /MODIFY command:

**Example 1 for /MODIFY command**

This is an example of a successful PREPARE, COMMIT sequence. In this example, DRD is not enabled. First, the command **/MODIFY PREPARE ALL** is issued.

Entry ET:

```
/MODIFY PREPARE ALL
```

Response ET:

```
DFS3499I ACTIVE DDNAMES MODBLKSA IMSACBA FORMATA MODSTAT ID: 103
```

Explanation: The modifications are brought online to IMS during a subsequent successful **/MODIFY COMMIT** command. The ddnames of the active data sets and the current MODSTAT identifier are shown. This message is the normal response.

### **Example 2 for /MODIFY command**

The following example show the modifications from a **/MODIFY PREPARE ACBLIB LTERM WTOR** command.

Entry ET:

```
/MODIFY PREPARE ACBLIB LTERM WTOR
```

Response ET:

```
DFS3499I ACTIVE DDNAMES: MODBLKSA IMSACBA FORMATA MODSTAT ID:
DFS3430I THE FOLLOWING MODIFICATIONS WILL OCCUR DURING /MODIFY COMMIT:
DFS3430I DMB      OLCDB115      CHANGED
DFS3430I DMB      OLCDB116      CHANGED
DFS3430I DMB      OLCDB117      CHANGED
DFS3430I DMB      OLCDB118      CHANGED
DFS3430I DMB      OLCDB119      CHANGED
DFS3430I PSB      BMP255        NOT CHANGED(DMB CHANGED ONLY)
DFS3430I END OF MODIFICATIONS
```

Explanation: The PSB references a DBD that is changed, but it is not required to be rebuilt. The DBDs' PSB copies are purged, and the PSB is read from ACBLIB the next time it is scheduled.

## Chapter 42. /MONITOR command

The **/MONITOR** command stops output from being sent to programmable remote stations (System/3). Input and output message queuing are allowed to continue.

The **/MONITOR** command can be used to reset conditions previously established by the **/START**, **/RSTART**, **/STOP**, **/PSTOP**, or **/PURGE** command.

This command can be issued to an IMSplex using the Batch SPOC utility.

Subsections:

- [“Environment” on page 905](#)
- [“Syntax” on page 905](#)
- [“Keywords” on page 905](#)
- [“Example” on page 905](#)

### Environment

The following table lists the environments (DB/DC, DBCTL, and DCCTL) in which you can use the command and keywords.

*Table 356. Valid environments for the /MONITOR command and keywords*

| Command / Keywords | DB/DC | DBCTL | DCCTL |
|--------------------|-------|-------|-------|
| <b>/MONITOR</b>    | X     |       | X     |
| LINE               | X     |       | X     |
| PTERM              | X     |       | X     |

### Syntax

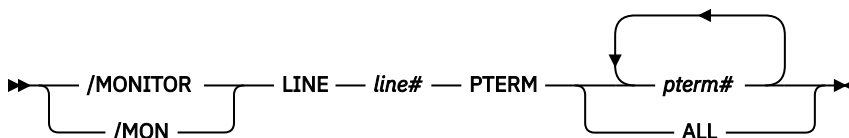

### Keywords

The following keywords are valid for the **/MONITOR** command:

#### LINE, PTERM

Specifies the communication line or physical terminal for which output is being stopped.

### Example

Entry ET:

```
/MONITOR LINE 4 PTERM 3
```

Response ET:

DFS058I MONITOR COMMAND COMPLETED

Response RT:

DFS059I TERMINAL MONITORED

Explanation: No further output is allowed to PTERM 3 on LINE 4.

---

## Chapter 43. /MSASSIGN command

The **/MSASSIGN** command alters the assignments of the following multisystem resources: LINK, MSPLINK, MSNAME, and SYSID. These assignments include logical link to physical link, remote system identification (SYSID) to logical link, logical link path (MSNAME) to logical link, and transaction to a local or remote system.

Subsections:

- [“Environment” on page 907](#)
- [“Syntax” on page 907](#)
- [“Keywords” on page 908](#)
- [“Usage notes” on page 909](#)
- [“Equivalent IMS type-2 commands” on page 909](#)
- [“Examples” on page 909](#)

### Environment

The following table lists the environments (DB/DC, DBCTL, and DCCTL) in which you can use the commands and keywords.

*Table 357. Valid environments for the /MSASSIGN command and keywords*

| Command / Keywords | DB/DC | DBCTL | DCCTL |
|--------------------|-------|-------|-------|
| <b>/MSASSIGN</b>   | X     |       | X     |
| LINK               | X     |       | X     |
| LOCAL              | X     |       | X     |
| MSNAME             | X     |       | X     |
| MSPLINK            | X     |       | X     |
| SYSID              | X     |       | X     |
| TRAN               | X     |       | X     |

### Syntax

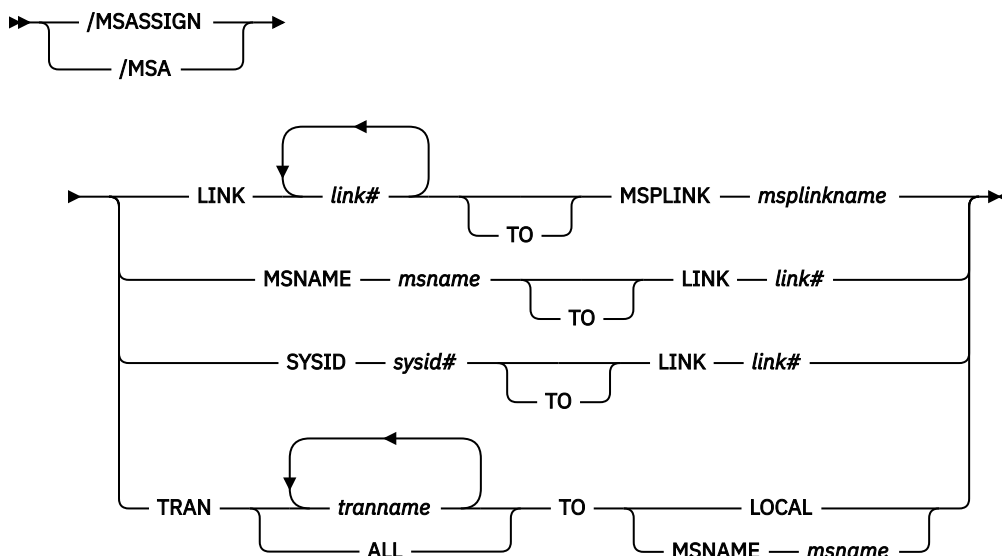

## Keywords

The following keywords are valid for the `/MSASSIGN` command:

### LINK

Specifies the logical link in a multiple system configuration.

Logical links can be assigned to physical links for input/output purposes. Only one logical link at a time can be assigned to a physical link (except for VTAM MSPLINKs, which can have multiple logical links assigned to them). The logical link must be stopped and idle for this assignment. Systems can only communicate with each other across a logical link established through specification of the same partner ID in both systems.

This type of assignment must be synchronized between the master terminal operators of the two systems. If a connection becomes inoperable while a transmission is in progress, this type of assignment allows switching to an alternate connection and proceeding with the unfinished transmission.

### LOCAL

Specifies the local system, that is the subsystem in which the command is issued. The command `/MSASSIGN TRAN p1 TO LOCAL` assigns transaction p1 to the local system.

### MSNAME

Specifies the logical link path in a multiple systems configuration.

### MSPLINK

Specifies the physical link in a multiple subsystem configuration.

The command `/MSASSIGN LINK p1 MSPLINK p2` assigns the logical link p1 to the physical link p2 for input and output purposes.

### SYSID

Specifies the system identification of a remote system in a multiple system configuration. Remote SYSIDs can be assigned to logical links for output purposes. More than one SYSID (=MSNAME) can be assigned to one logical link. A remote SYSID (=MSNAME) cannot be assigned to another logical link if a message is currently transmitting on the connection corresponding to this SYSID. Therefore, the logical link must be stopped and idle for this assignment.

### TRAN

Specifies the transaction to be assigned to either the local or the remote system.

For successful completion of the command:



- The transactions must be stopped.
- When assigning a remote transaction to local, a local APPLCTN macro (no SYSID parameter) for the corresponding program (PSB) must have been included in the system definition. There must be a local as well as a remote PSB of the same name defined during system definition.

The **/MSASSIGN TRAN** command cannot be used for the CPI Communications driven transaction program.

## Usage notes

All changes made by an **/MSASSIGN** command remain until changed with another **/MSASSIGN** command or an IMS cold start is performed. After the **/MSASSIGN** command is used, **/MSVERIFY** should be used to ensure that the assignment produced a valid configuration.

The **/MSASSIGN TRAN *tranname* TO LOCAL** command sets the remote system ID to be the same as the local system ID. It is equivalent to the command `UPDATE TRAN NAME(tranname) SET(REMOTE(N),SIDR(localsysid),SIDL(localsysid))`.

This command can be issued to an IMSplex by using the Batch SPOC utility.

## Equivalent IMS type-2 commands

The following table shows variations of the **/MSASSIGN** command and the IMS type-2 commands that perform similar functions.

Table 358. Type-2 equivalents for the **/MSASSIGN** command

| Task   | <b>/MSASSIGN</b> command                                      | Similar IMS type-2 command                                     |
|--|---|--|
| Changes the transaction so that it is local and runs on the local system.                    | <b>/MSASSIGN TRAN <i>tranname</i> TO LOCAL</b>                | UPDATE TRAN NAME( <i>tranname</i> ) SET(REMOTE(N))             |
| Changes the transaction so that it is remote, and assign it to a specific logical link path. | <b>/MSASSIGN TRAN <i>tranname</i> TO MSNAME <i>msname</i></b> | UPDATE TRAN NAME( <i>tranname</i> ) SET(MSNAME( <i>name</i> )) |

### Examples

The following are examples of the **/MSASSIGN** command:

#### **Example 1 for /MSASSIGN command**

Entry ET:

```
/MSASSIGN LINK 2 TO MSPLINK BBB
```

Response ET:

```
DFS058I MSASSIGN COMMAND COMPLETED
```

Explanation: The input system now has a logical connection to physical link BBB for all the SYSIDs assigned to link 2.

#### **Example 2 for /MSASSIGN command**

Entry ET:

```
/MSASSIGN MSNAME BOSTON TO LINK 3
```

Response ET:

```
DFS058I  MSASSIGN COMMAND COMPLETED
```

Explanation: The MSNAME BOSTON and its associated SYSID (19) have been reassigned to link 3. Link 3 can be used to associate all its SYSIDs with a main storage-to-main storage connection as opposed to a channel-to-channel or a bisynchronous connection.

**Example 3 for /MSASSIGN command**

Entry ET:

```
/MSASSIGN SYSID 19 TO LINK 2
```

Response ET:

```
DFS058I  MSASSIGN COMMAND COMPLETED
```

Explanation: SYSID 19 might have been originally assigned to link 1 in the remote system and known by the MSNAME of CHICAGO. In this example, SYSID 19 (CHICAGO) is reassigned to link 2. This assignment can be made when both link 1 and link 2 are connected to the same two IMS systems and link 1 is inoperable.

**Example 4 for /MSASSIGN command**

Entry ET:

```
/MSASSIGN TRAN XYZ TO MSNAME LNKY
```

Response ET:

```
DFS058I  MSASSIGN COMMAND COMPLETED
```

Explanation: Local and remote SYSIDs of transaction XYZ are assigned to the link associated with MSNAME LNKY.

**Related reference**

[UPDATE TRAN command \(Commands\)](#)

[UPDATE MSNAME command \(Commands\)](#)

## Chapter 44. /MSVERIFY command

The **/MSVERIFY** command verifies local transactions and local LTERMs for corresponding remote transactions and remote LTERMs.

The **/MSVERIFY** command also verifies the consistency of the attributes of corresponding transactions. For instance, Fast Path exclusive transactions cause an error message to be returned because the transactions can only be processed as local transactions. Defined paths that are usable between the two systems can also be verified with this command.

Subsections:

- [“Environment” on page 911](#)
- [“Syntax” on page 911](#)
- [“Keywords” on page 911](#)
- [“Usage notes” on page 911](#)
- [“Examples” on page 912](#)

### Environment

The following table lists the environments (DB/DC, DBCTL, and DCCTL) in which you can use the commands and keywords.

Table 359. Valid environments for the /MSVERIFY command and keywords

| Command / Keywords | DB/DC | DBCTL | DCCTL |
|--------------------|-------|-------|-------|
| <b>/MSVERIFY</b>   | X     |       | X     |
| MSNAME             | X     |       | X     |
| SYSID              | X     |       | X     |

### Syntax



### Keywords

The following keywords are valid for the **/MSVERIFY** command:

#### **MSNAME**

Specifies the logical link path in a multiple systems configuration.

#### **SYSID**

Specifies the remote system identification of a system in a multiple systems configuration.

### Usage notes

The IMS Multiple Systems Verification utility is run offline following system definition. The **/MSVERIFY** command is used during online execution when verification of two systems is desired, such as after an **/MSASSIGN** command has been entered.

**Restrictions:** The **/MSVERIFY** command has the following restrictions:

- Only one remote system can be specified for each **/MSVERIFY** command.
- The **/MSVERIFY** command does not apply to Intersystem Communication (ISC) or directed routing.

### Examples

The following are examples of the **/MSVERIFY** command:

#### **Example 1 for /MSVERIFY command**

Entry ET:

```
/MSVERIFY MSNAME ABC
```

Response ET:

```
DFS2234I MSVERIFY COMMAND IN PROGRESS FOR LOCAL  
SYSIDS 001,002,003,004 dddddd
```

Explanation: Assume SYSID numbers 001 through 004 are defined as local in the input system. dddddd is the time stamp.

Response ET:

```
DFS2243 TA11A IS NOT DEFINED AS TRANSACTION  
IN BOTH SYSTEMS.
```

Explanation: TA11A is defined as a remote transaction in one system but is not defined as a transaction in the partner system.

Response ET:

```
DFS2237I MSVERIFY COMPLETED FOR LOCAL SYSID 001  
ddddd
```

Explanation: Verification of local SYSID 001 is completed. The response message is repeated for local SYSIDs 002, 003, and 004 if all verify. dddddd is the time stamp.

Response ET:

```
DFS2235I SYSID 004 IS DEFINED AS LOCAL IN BOTH  
SYSTEMS. dddddd
```

Explanation: SYSID 004 has no corresponding remote SYSID. dddddd is the time stamp.

Remote SYSIDs are processed next.

Response ET:

```
DFS2236I MSVERIFY COMMAND IN PROGRESS FOR REMOTE  
SYSIDS 005,006,007,008 dddddd
```

Response ET:

```
DFS2237I MSVERIFY COMPLETED FOR SYSID 005  
ddddd
```

Explanation: The verification of one remote SYSID is completed. The response is repeated for remote SYSIDs 006, 007, and 008 if all verify. dddddd is the time stamp.

#### **Example 2 for /MSVERIFY command**

Entry ET:

```
/MSVERIFY SYSID 8
```

Explanation: The input system sends a list of its local SYSIDs to the remote system and then displays the following message on the input terminal.

Response ET:

```
DFS2234I MSVERIFY COMMAND IN PROGRESS FOR LOCAL SYSIDS  
001, 002, 003, 004 dddddd
```

Explanation: Assume SYSID numbers 001 through 004 are defined as local in the input system.

As the input system completes processing of the information returned for each of the input system's local SYSIDs, the following message is displayed on the input terminal:

Response RT:

```
DFS2237I MSVERIFY COMPLETED FOR SYSID 001  
ddddd
```

Explanation: The verification of local SYSID 001 is completed. The response message is repeated for local SYSIDs 002, 003, 004 if all verify. Verification is complete only if a DFS2237I message is received for every SYSID identified in the DFS2234I message. Definition and assignment errors can cause conditions that prevent these messages from being returned. Stopped or unassigned links can also prevent the return of the message. dddddd is the time stamp.

Remote SYSIDs are processed next. The input system sends all its pertinent information related to the remote system's local SYSIDs and displays the following message:

Response ET:

```
DFS2236I MSVERIFY COMMAND IN PROGRESS FOR REMOTE  
SYSIDS 005, 006, 007, and 008 dddddd
```

As the remote system completes processing of the information it received for each of its local SYSIDs, the following message is displayed on the input terminal. dddddd is the time stamp.

Response ET:

```
DFS2237I MSVERIFY COMPLETED FOR SYSID 005  
ddddd
```

Explanation: The verification of one remote SYSID is complete. The last response message is repeated for remote SYSIDs 006, 007, 008 if all verify. dddddd is the time stamp.



## Notices

---

This information was developed for products and services offered in the US. This material might be available from IBM in other languages. However, you may be required to own a copy of the product or product version in that language in order to access it.

IBM may not offer the products, services, or features discussed in this document in other countries. Consult your local IBM representative for information on the products and services currently available in your area. Any reference to an IBM product, program, or service is not intended to state or imply that only that IBM product, program, or service may be used. Any functionally equivalent product, program, or service that does not infringe any IBM intellectual property right may be used instead. However, it is the user's responsibility to evaluate and verify the operation of any non-IBM product, program, or service.

IBM may have patents or pending patent applications covering subject matter described in this document. The furnishing of this document does not grant you any license to these patents. You can send license inquiries, in writing, to:

*IBM Director of Licensing IBM Corporation North Castle Drive, MD-NC119 Armonk, NY 10504-1785 US*

For license inquiries regarding double-byte character set (DBCS) information, contact the IBM Intellectual Property Department in your country or send inquiries, in writing, to:

*Intellectual Property Licensing Legal and Intellectual Property Law IBM Japan, Ltd. 19-21, Nihonbashi-Hakozakicho, Chuo-ku Tokyo 103-8510, Japan*

INTERNATIONAL BUSINESS MACHINES CORPORATION PROVIDES THIS PUBLICATION "AS IS" WITHOUT WARRANTY OF ANY KIND, EITHER EXPRESS OR IMPLIED, INCLUDING, BUT NOT LIMITED TO, THE IMPLIED WARRANTIES OF NON-INFRINGEMENT, MERCHANTABILITY OR FITNESS FOR A PARTICULAR PURPOSE. Some jurisdictions do not allow disclaimer of express or implied warranties in certain transactions, therefore, this statement may not apply to you.

This information could include technical inaccuracies or typographical errors. Changes are periodically made to the information herein; these changes will be incorporated in new editions of the publication. IBM may make improvements and/or changes in the product(s) and/or the program(s) described in this publication at any time without notice.

Any references in this information to non-IBM websites are provided for convenience only and do not in any manner serve as an endorsement of those websites. The materials at those websites are not part of the materials for this IBM product and use of those websites is at your own risk.

IBM may use or distribute any of the information you provide in any way it believes appropriate without incurring any obligation to you.

Licensees of this program who wish to have information about it for the purpose of enabling: (i) the exchange of information between independently created programs and other programs (including this one) and (ii) the mutual use of the information which has been exchanged, should contact:

*IBM Director of Licensing IBM Corporation North Castle Drive, MD-NC119 Armonk, NY 10504-1785 US*

Such information may be available, subject to appropriate terms and conditions, including in some cases, payment of a fee.

The licensed program described in this document and all licensed material available for it are provided by IBM under terms of the IBM Customer Agreement, IBM International Program License Agreement or any equivalent agreement between us.

The performance data and client examples cited are presented for illustrative purposes only. Actual performance results may vary depending on specific configurations and operating conditions.

Information concerning non-IBM products was obtained from the suppliers of those products, their published announcements or other publicly available sources. IBM has not tested those products and

cannot confirm the accuracy of performance, compatibility or any other claims related to non-IBM products. Questions on the capabilities of non-IBM products should be addressed to the suppliers of those products.

Statements regarding IBM's future direction or intent are subject to change or withdrawal without notice, and represent goals and objectives only.

This information contains examples of data and reports used in daily business operations. To illustrate them as completely as possible, the examples include the names of individuals, companies, brands, and products. All of these names are fictitious and any similarity to actual people or business enterprises is entirely coincidental.

#### COPYRIGHT LICENSE:

This information contains sample application programs in source language, which illustrate programming techniques on various operating platforms. You may copy, modify, and distribute these sample programs in any form without payment to IBM, for the purposes of developing, using, marketing or distributing application programs conforming to the application programming interface for the operating platform for which the sample programs are written. These examples have not been thoroughly tested under all conditions. IBM, therefore, cannot guarantee or imply reliability, serviceability, or function of these programs. The sample programs are provided "AS IS", without warranty of any kind. IBM shall not be liable for any damages arising out of your use of the sample programs.

Each copy or any portion of these sample programs or any derivative work must include a copyright notice as follows: © (your company name) (year). Portions of this code are derived from IBM Corp. Sample Programs. © Copyright IBM Corp. \_enter the year or years\_.

## Programming interface information

---

This information documents Product-sensitive Programming Interface and Associated Guidance Information provided by IMS.

Product-sensitive Programming Interfaces allow the customer installation to perform tasks such as diagnosing, modifying, monitoring, repairing, tailoring, or tuning of this software product. Use of such interfaces creates dependencies on the detailed design or implementation of the IBM software product. Product-sensitive Programming Interfaces should be used only for these specialized purposes. Because of their dependencies on detailed design and implementation, it is to be expected that programs written to such interfaces may need to be changed in order to run with new product releases or versions, or as a result of service. Product-sensitive Programming Interface and Associated Guidance Information is identified where it occurs, either by an introductory statement to a section or topic, or by a Product-sensitive programming interface label. IBM requires that the preceding statement, and any statement in this information that refers to the preceding statement, be included in any whole or partial copy made of the information described by such a statement.

## Trademarks

---

IBM, the IBM logo, and [ibm.com](http://www.ibm.com)® are trademarks or registered trademarks of International Business Machines Corp., registered in many jurisdictions worldwide. Other product and service names might be trademarks of IBM or other companies. A current list of IBM trademarks is available on the web at "Copyright and trademark information" at <http://www.ibm.com/legal/copytrade.shtml>.

Adobe, the Adobe logo, and the PostScript logo are either registered trademarks or trademarks of Adobe Systems Incorporated in the United States, and/or other countries.

Linux® is a registered trademark of Linus Torvalds in the United States, other countries, or both.

Microsoft, Windows, Windows NT, and the Windows logo are trademarks of Microsoft Corporation in the United States, other countries, or both.

Java and all Java-based trademarks and logos are trademarks or registered trademarks of Oracle and/or its affiliates.



UNIX is a registered trademark of The Open Group in the United States and other countries.

## Terms and conditions for product documentation

---

Permissions for the use of these publications are granted subject to the following terms and conditions.

### Applicability

These terms and conditions are in addition to any terms of use for the IBM website.

### Personal use

You may reproduce these publications for your personal, noncommercial use provided that all proprietary notices are preserved. You may not distribute, display or make derivative work of these publications, or any portion thereof, without the express consent of IBM.

### Commercial use

You may reproduce, distribute and display these publications solely within your enterprise provided that all proprietary notices are preserved. You may not make derivative works of these publications, or reproduce, distribute or display these publications or any portion thereof outside your enterprise, without the express consent of IBM.

### Rights

Except as expressly granted in this permission, no other permissions, licenses or rights are granted, either express or implied, to the publications or any information, data, software or other intellectual property contained therein.

IBM reserves the right to withdraw the permissions granted herein whenever, in its discretion, the use of the publications is detrimental to its interest or, as determined by IBM, the above instructions are not being properly followed.

You may not download, export or re-export this information except in full compliance with all applicable laws and regulations, including all United States export laws and regulations.

IBM MAKES NO GUARANTEE ABOUT THE CONTENT OF THESE PUBLICATIONS. THE PUBLICATIONS ARE PROVIDED "AS-IS" AND WITHOUT WARRANTY OF ANY KIND, EITHER EXPRESSED OR IMPLIED, INCLUDING BUT NOT LIMITED TO IMPLIED WARRANTIES OF MERCHANTABILITY, NON-INFRINGEMENT, AND FITNESS FOR A PARTICULAR PURPOSE.

## IBM Online Privacy Statement

---

IBM Software products, including software as a service solutions, (“Software Offerings”) may use cookies or other technologies to collect product usage information, to help improve the end user experience, to tailor interactions with the end user or for other purposes. In many cases no personally identifiable information is collected by the Software Offerings. Some of our Software Offerings can help enable you to collect personally identifiable information. If this Software Offering uses cookies to collect personally identifiable information, specific information about this offering’s use of cookies is set forth below.

This Software Offering does not use cookies or other technologies to collect personally identifiable information.

If the configurations deployed for this Software Offering provide you as customer the ability to collect personally identifiable information from end users via cookies and other technologies, you should seek your own legal advice about any laws applicable to such data collection, including any requirements for notice and consent.

To learn more, see [IBM Privacy Statement](#).



# Bibliography

---

This bibliography lists all of the publications in the IMS 15.3 library.

| <b>Title</b>  | <b>Acronym</b> |
|---|----------------|
| <i>IMS Version 15.3 Application Programming</i>                             | APG            |
| <i>IMS Version 15.3 Application Programming APIs</i>                        | APR            |
| <i>IMS Version 15.3 Commands, Volume 1: IMS Commands A-M</i>                | CR1            |
| <i>IMS Version 15.3 Commands, Volume 2: IMS Commands N-V</i>                | CR2            |
| <i>IMS Version 15.3 Commands, Volume 3: IMS Component and z/OS Commands</i> | CR3            |
| <i>IMS Version 15.3 Communications and Connections</i>                      | CCG            |
| <i>IMS Version 15.3 Database Administration</i>                             | DAG            |
| <i>IMS Version 15.3 Database Utilities</i>                                  | DUR            |
| <i>IMS Version 15.3 Diagnosis</i>   | DGR            |
| <i>IMS Version 15.3 Exit Routines</i>                                       | ERR            |
| <i>IMS Version 15.3 Installation</i>  | INS            |
| <i>IMS Version 15.3 Licensed Program Specifications</i>                     | LPS            |
| <i>IMS Version 15.3 Messages and Codes, Volume 1: DFS Messages</i>          | MC1            |
| <i>IMS Version 15.3 Messages and Codes, Volume 2: Non-DFS Messages</i>      | MC2            |
| <i>IMS Version 15.3 Messages and Codes, Volume 3: IMS Abend Codes</i>       | MC3            |
| <i>IMS Version 15.3 Messages and Codes, Volume 4: IMS Component Codes</i>   | MC4            |
| <i>IMS Version 15.3 Operations and Automation</i>                           | OAG            |
| <i>IMS Version 15.3 Release Planning</i>                                    | RPG            |
| <i>IMS Version 15.3 System Administration</i>                               | SAG            |
| <i>IMS Version 15.3 System Definition</i>                                   | SDG            |
| <i>IMS Version 15.3 System Programming APIs</i>                             | SPR            |
| <i>IMS Version 15.3 System Utilities</i>                                    | SUR            |



---

# Index

## Special Characters

- /ACTIVATE command
  - description [99](#)
  - environments [99](#)
  - examples [100](#)
  - syntax [99](#)
- /ALLOCATE command
  - description [101](#)
  - environments [101](#)
  - syntax [101](#)
- /ASSIGN command
  - description [112](#)
  - dynamic terminals, using in [114](#)
  - environments [103](#)
  - examples [115](#)
  - restriction [113](#)
  - static terminals, using in [113](#)
  - syntax [104](#)
  - VTAM terminals, using in [114](#)
- /BROADCAST command
  - description [121](#)
  - environment [121](#)
  - examples [124](#)
  - keywords [122](#)
  - requirement [123](#)
  - syntax [121](#)
  - usage notes [123](#)
- /CANCEL command
  - description [127](#)
  - environments [127](#)
  - example [127](#)
  - syntax [127](#)
  - usage notes [127](#)
- /CHANGE command
  - APPC keyword
    - description [129](#)
    - environment [129](#)
    - keywords [130](#)
    - syntax [130](#)
    - usage notes [130](#)
  - CCTL keyword
    - description [130](#)
    - environment [130](#)
    - examples [131](#)
    - keywords [131](#)
    - syntax [131](#)
  - CPLOG keyword
    - description [132](#)
    - environment [132](#)
    - keywords [132](#)
    - syntax [132](#)
  - DESC keyword
    - description [132](#)
    - environment [133](#)
    - keywords [133](#)
    - syntax [133](#)
  - /CHANGE command (*continued*)
    - DESC keyword (*continued*)
      - usage notes [134](#)
    - description [129](#)
    - DIR MFS keyword
      - description [134](#)
      - environment [135](#)
      - syntax [135](#)
      - usage notes [135](#)
    - FDR keyword
      - description [135](#)
      - environment [135](#)
      - syntax [136](#)
      - usage notes [136](#)
    - LINK keyword
      - description [136](#)
      - environment [136](#)
      - examples, ASR [139](#)
      - examples, TCP/IP links [138](#)
      - keywords [137](#)
      - syntax [137](#)
    - NODE keyword
      - description [140](#)
      - environment [140](#)
      - examples [142](#)
      - keywords [141](#)
      - syntax [141](#)
    - SUBSYS keyword
      - description [143](#)
      - environment [144](#)
      - examples [144](#)
      - keywords [144](#)
      - syntax [144](#)
    - SURV keyword
      - description [145](#)
      - environment [145](#)
      - examples [147](#)
      - keywords [146](#)
      - syntax [145](#)
      - usage notes [146](#)
    - TRAN keyword
      - description [148](#)
      - environment [148](#)
      - examples [148](#)
      - keywords [148](#)
      - syntax [148](#)
    - UOR keyword
      - description [149](#)
      - environment [149](#)
      - examples [150](#)
      - keywords [150](#)
      - syntax [150](#)
    - USER keyword
      - description [151](#)
      - environment [151](#)
      - keywords [151](#)
      - syntax [151](#)

/CHANGE LINK command  
   examples, ASR [139](#)  
   examples, TCP/IP links [138](#)

/CHECKPOINT command  
   description [153](#)  
   environment [153](#)  
   examples [157](#)  
   shutdown  
     description [153](#)  
   simple checkpoint  
     description [153](#)  
   statistics checkpoint  
     description [154](#)  
   usage notes [156](#)

/CLSDST command  
   description [159](#)  
   environment [159](#)  
   example [161](#)  
   syntax [159](#)  
   usage notes [160](#)

/COMPT command  
   description [163](#)  
   environment [163](#)  
   examples [165](#)  
   parameters [164](#)  
   syntax [163](#)  
   usage notes [165](#)

/CQCHKPT command  
   description [167](#)  
   environment [167](#)  
   examples [168](#)  
   syntax [167](#)  
   usage notes [168](#)

/CQQUERY command  
   description [169](#)  
   environment [169](#)  
   examples [170](#)  
   keywords [169](#)  
   syntax [169](#)  
   usage notes [169](#)

/CQSET command  
   description [173](#)  
   environment [173](#)  
   examples [174](#)  
   syntax [173](#)  
   usage notes [174](#)

/DBDUMP command  
   description [329](#)  
   environment [329](#)  
   examples [332](#)  
   keywords [329](#)  
   syntax [329](#)  
   usage notes [331](#)

/DBRECOVERY command  
   description [335](#)  
   environment [335](#)  
   examples [340](#)  
   keywords [336](#)  
   syntax [335](#)  
   usage notes [338](#)

/DELETE command  
   description [343](#)  
   environment [343](#)  
   keywords [343](#)

/DELETE command (*continued*)  
   syntax [343](#)

/DEQUEUE command  
   description [451](#)  
   environment [451](#)  
   examples [456](#), [457](#)  
   keywords [452](#)  
   usage notes [456](#)

/DFSTCF LOAD command  
   description [459](#)

/DIAGNOSE command  
   description [461](#), [462](#)  
   environment [461](#), [462](#)  
   example [462](#), [494](#)  
   keywords [466](#)  
   SET keyword [461](#)  
   SNAP keyword [466](#)  
   syntax [461](#), [463](#)

/DISPLAY command  
   ACT keyword  
     CLASS [521](#)  
     DC [515](#)  
     description [514](#)  
     environments [514](#)  
     examples [522](#)  
     JOBNAME [517](#)  
     OTMA GROUP [515](#)  
     PROGRAM [518](#)  
     REGID [517](#)  
     REGION [515](#)  
     STATUS [516](#), [518](#)  
     syntax [514](#)  
     TRANSACTION/STEP  
       [517](#)  
     TYPE [517](#)  
     usage notes [515](#)  
     VTAM ACB [515](#)

  AFFIN keyword  
     description [529](#)  
     environments [529](#)  
     examples [530](#)  
     output fields [532](#)  
     syntax [529](#)  
     usage notes [530](#)

  AOITKN keyword  
     description [531](#)  
     environment [531](#)  
     examples [532](#)  
     syntax [531](#)  
     usage notes [531](#)

  APPC keyword  
     description [532](#)  
     environment [532](#)  
     examples [534](#)  
     output fields [533](#)  
     syntax [532](#)

  AREA keyword  
     description [534](#)  
     environments [534](#)  
     examples [538](#)  
     output fields [536](#)  
     syntax [535](#)  
     usage notes [535](#)

  ASMT keyword

/DISPLAY command (continued)

- ASMT keyword (continued)
  - description [540](#)
  - environments [540](#)
  - examples [543](#)
  - syntax [540](#)
- CCTL keyword
  - description [549](#)
  - environments [549](#)
  - examples [550](#)
  - keywords [550](#)
  - output fields [550](#)
  - syntax [550](#)
- CONV keyword
  - description [552](#)
  - environments [552](#)
  - examples [554](#)
  - output fields [554](#)
  - syntax [552](#)
  - usage notes [553](#)
- CPLOG keyword
  - description [556](#)
  - environments [556](#)
  - syntax [556](#)
- CQS keyword
  - description [557](#)
  - environments [557](#)
  - examples [557](#)
  - syntax [557](#)
- DB keyword
  - description [557](#)
  - environments [558](#)
  - examples [563](#)
  - output fields [561](#)
  - syntax [558](#)
  - usage notes [560](#)
- DB keyword with BKERR
  - description [562](#)
- DBD keyword
  - description [567](#)
  - environments [567](#)
  - examples [567](#)
  - syntax [567](#)
- DESC keyword
  - description [568](#)
  - environments [568](#)
  - examples [569](#)
  - output fields [568](#)
  - syntax [568](#)
- description [499](#)
- FDR keyword
  - description [569](#)
  - environments [569](#)
  - examples [570](#)
  - output fields [569](#)
  - syntax [569](#)
- FPV keyword
  - description [570](#)
  - environments [570](#)
  - examples [571](#)
  - output fields [570](#)
  - syntax [570](#)
- HSSP keyword
  - description [572](#)

/DISPLAY command (continued)

- HSSP keyword (continued)
  - environments [572](#)
  - examples [573](#)
  - output fields [573](#)
  - syntax [572](#)
- LINE keyword
  - description [574](#)
  - environments [574](#)
  - examples [577](#)
  - keywords [575](#)
  - reserved parameters [575](#)
  - syntax [574](#)
- LINK keyword
  - description [578](#)
  - environments [578](#)
  - examples [580](#)
  - keywords [579](#)
  - output fields [579](#)
  - syntax [578](#)
  - usage notes [579](#)
- LTERM keyword
  - description [581](#)
  - EMHQ [582](#)
  - environments [582](#)
  - examples [584](#)
  - keywords [582](#)
  - QCNT [582](#)
  - syntax [582](#)
  - usage notes [583](#)
- LU keyword
  - environments [585](#)
  - examples [588](#)
  - syntax [586](#)
- LUNAME keyword
  - description [585](#)
  - keywords [586](#)
  - output fields [587](#)
- MASTER keyword
  - description [590](#)
  - environments [590](#)
  - examples [591](#)
  - syntax [591](#)
- MODIFY keyword
  - description [591](#)
  - environments [592](#)
  - examples [598](#)
  - keywords [592](#)
  - output fields [594](#)
  - syntax [592](#)
  - usage notes [594](#)
- MSNAME keyword
  - description [603](#)
  - environments [603](#)
  - examples [604](#)
  - keywords [604](#)
  - syntax [604](#)
- NODE keyword
  - description [605](#)
  - EMHQ [608](#)
  - environments [605](#)
  - examples [611](#)
  - keywords [607](#)
  - MODE [608](#)

/DISPLAY command (continued)

NODE keyword (continued)

QCNT [608](#)  
syntax [606](#)  
usage notes [609](#)

OASN SUBSYS keyword

description [616](#)  
environments [616](#)  
examples [616](#)  
syntax [616](#)

OLDS keyword

description [617](#)  
environments [617](#)  
examples [619](#)  
keywords [618](#)  
syntax [617](#)  
usage notes [618](#)

OTMA keyword

description [620](#)  
environments [620](#)  
examples [622](#)  
output fields [621](#)  
syntax [620](#)

OVERFLOWQ keyword

description [625](#)  
environments [625](#)  
examples [627](#)  
keywords [626](#)  
output fields [626](#)  
syntax [625](#)  
usage notes [626](#)

PGM keyword

description [628](#)  
environments [628](#)  
syntax [628](#)  
usage notes [629](#)

POOL keyword

description [630](#)  
environments [631](#)  
examples [640](#)  
syntax [631](#)  
usage notes [632](#)

PSB keyword

description [648](#)  
environments [649](#)  
examples [649](#)  
syntax [649](#)  
usage notes [649](#)

PTERM keyword

description [650](#)  
environments [650](#)  
examples [652](#)  
syntax [650](#)  
usage notes [651](#)

Q keyword

description [652](#)  
environments [652](#)  
examples [653](#)  
keywords [653](#)  
syntax [653](#)

QCNT keyword

description [656](#)  
environments [656](#)  
examples [658](#)

/DISPLAY command (continued)

QCNT keyword (continued)

output fields [658](#)  
syntax [657](#)  
usage notes [657](#)

RECOVERY keyword

description [660](#)  
environments [660](#)  
examples [663](#)  
keywords [660](#)  
output fields [662](#)  
syntax [660](#)  
usage notes [661](#)

RTCODE keyword

description [666](#)  
environments [666](#)  
examples [666](#)  
syntax [666](#)

SHUTDOWN STATUS

keyword  
description [667](#)  
environments [667](#)  
examples [670](#)  
syntax [667](#)  
usage notes [667](#)

STATUS keyword

description [672](#)  
environments [672](#)  
examples [675](#)  
syntax [673](#)  
usage notes [673](#)

STRUCTURE keyword

description [679](#)  
environments [679](#)  
examples [680](#)  
syntax [679](#)  
usage notes [679](#)

SUBSYS keyword

description [680](#)  
environments [681](#)  
examples [682](#)  
syntax [681](#)  
usage notes [681](#)

SYSID TRANSACTION

keyword  
environments [683](#)  
examples [684](#)  
syntax [684](#)

TIMEOVER keyword

description [684](#)  
environments [684](#)  
examples [685](#)  
keywords [684](#)  
syntax [684](#)  
usage notes [685](#)

TMEMBER keyword

description [685](#)  
environments [685](#)  
examples [685](#)  
output fields [688](#)  
syntax [685](#)  
usage notes [685](#)

TMEMBER QCNT keyword

description [686](#)



*/DISPLAY command (continued)*

TMEMBER TPIPE keyword  
description [686](#)

TMEMBER TPIPE OUTPUT  
keyword  
description [687](#)

TMEMBER TPIPE QCNT  
keyword  
description [687](#)

TMEMBER TPIPE SYNC  
keyword  
description [687](#)

TRACE keyword  
description [697](#)  
environments [698](#)  
examples [701](#)  
keywords [699](#)  
output fields [700](#)  
syntax [698](#)  
usage notes [699](#)

TRAN keyword  
description [707](#)  
environments [707](#)  
examples [710](#)  
keywords [708](#)  
output fields [709](#)  
QCNT [708](#)  
syntax [708](#)  
usage notes [709](#)

TRANSACTION keyword  
description [683](#)

UOR keyword  
description [711](#), [712](#)  
environments [712](#)  
examples [713](#)  
output fields [712](#)  
syntax [712](#)

USER keyword  
description [715](#)  
environments [715](#)  
examples [719](#)  
keywords [716](#)  
syntax [715](#)  
usage notes [717](#)

*/DISPLAY MODIFY command*  
library status information [594](#)

*/END command*  
description [723](#)  
environment [723](#)  
example [724](#)  
keywords [723](#)  
syntax [723](#)  
usage notes [724](#)

*/ERESTART command*  
description [725](#)  
environment [725](#)  
example [725](#)  
keywords [725](#)  
syntax [725](#)  
usage notes [725](#)

*/EXCLUSIVE command*  
description [735](#)  
environment [735](#)  
example [736](#)

*/EXCLUSIVE command (continued)*

keywords [735](#)  
syntax [735](#)  
usage notes [736](#)

*/EXIT command*  
description [737](#)  
environment [737](#)  
examples [739](#)  
keywords [738](#)  
syntax [737](#)  
usage notes [738](#)

*/FORMAT command*  
description [769](#)  
environment [769](#)  
example [770](#)  
keywords [769](#)  
syntax [769](#)  
usage notes [770](#)

*/HOLD command*  
description [771](#)  
environment [771](#)  
example [771](#)  
syntax [771](#)  
usage notes [771](#)

*/IDLE command*  
description [773](#)  
environment [773](#)  
examples [775](#)  
keywords [774](#)  
syntax [773](#)

*/LOCK command*  
description [889](#)  
environment [889](#)  
examples [892](#)  
keywords [890](#)  
syntax [889](#)  
usage notes [891](#)

*/LOG command*  
description [895](#)  
environment [895](#)  
example [895](#)  
keywords [895](#)  
syntax [895](#)

*/LOOPTEST command*  
description [897](#)  
environment [897](#)  
example [898](#)  
syntax [897](#)

*/MODIFY command*  
description [899](#)  
environment [899](#)  
examples [903](#)  
keywords [900](#)  
syntax [899](#)  
usage notes [902](#)

*/MONITOR command*  
description [905](#)  
environment [905](#)  
example [905](#)  
keywords [905](#)

*/MSASSIGN command*  
description [907](#)  
environment [907](#)  
examples [909](#)

/MSASSIGN command (*continued*)  
  keywords [908](#)  
  syntax [907](#)  
  usage notes [909](#)  
/MSVERIFY command  
  description [911](#)  
  environment [911](#)  
  examples [912](#)  
  keywords [911](#)  
  syntax [911](#)  
  usage notes [911](#)

## Numerics

3270 Information Display System  
  display screen [2](#)  
  MFS bypass [31](#)  
  multisegment command input  
    description [5](#)  
    example [5](#)  
  printer [2](#)  
3270 terminal  
  FORMAT command [770](#)  
3275 terminal  
  COMPONENT keyword [106](#)  
3770 terminal  
  COMPONENT keyword [107](#)

## A

ABDUMP keyword  
  CHECKPOINT command [154](#)  
ABORT keyword  
  MODIFY Command [900](#)  
accessibility  
  features [xi](#)  
  keyboard shortcuts [xi](#)  
ACT keyword  
  /DISPLAY command  
    CLASS [521](#)  
    DC [515](#)  
    JOBNAME [517](#)  
    OTMA GROUP [515](#)  
    PROGRAM [518](#)  
    REGID [517](#)  
    REGION [515](#)  
    STATUS [516](#), [518](#)  
    TRANSACTION/STEP  
      [517](#)  
    TYPE [517](#)  
    VTAM ACB [515](#)  
  DISPLAY command  
    description [514](#)  
ACTIVATE command  
  description [99](#)  
  environments [99](#)  
  examples [100](#)  
  LINK keyword [99](#)  
  NODE keyword [99](#)  
  syntax [99](#)  
ACTIVE keyword  
  BROADCAST command [122](#)  
active system

active system (*continued*)  
  status [514](#)  
AFFIN keyword  
  DISPLAY command  
    description [529](#)  
ALL parameter  
  KEYWD macro statement [16](#)  
  specifying [16](#)  
ALLOCATE command  
  description [101](#)  
  environments [101](#)  
  LUNAME keyword [101](#)  
  MODE keyword [101](#)  
  syntax [101](#)  
  TPNAME keyword [102](#)  
ALTER option  
  INITIATE OLREORG command [878](#)  
AO (automated operator) application  
  CMD call [29](#)  
  commands supported [29](#)  
  ICMD call [31](#)  
  using CMD [29](#)  
  using ICMD [32](#)  
AOI (automated operator interface) [29](#)  
AOITKN keyword  
  DISPLAY command  
    description [531](#)  
AOITOKEN keyword  
  DEQUEUE command [452](#)  
APPC keyword  
  DISPLAY command  
    description [532](#)  
AREA keyword  
  DBRECOVERY command [336](#)  
  DISPLAY command  
    description [534](#)  
    example [538](#)  
ASMT keyword  
  DISPLAY command  
    description [540](#)  
    example [543](#)  
ASSIGN command  
  CLASS keyword [106](#)  
  COMPONENT keyword [106](#)  
  CPRI keyword [107](#)  
  description [112](#)  
  dynamic terminals, using in [114](#)  
  environments [103](#)  
  equivalent IMS type-2 commands [114](#)  
  examples [115](#)  
  ICOMPONENT keyword [107](#)  
  IMSplex, using in [113](#)  
  INPUT keyword [107](#)  
  LINE keyword [107](#)  
  LMCT keyword [107](#)  
  LPRI keyword [107](#)  
  LTERM keyword  
    data considerations [109](#)  
    description [107](#)  
    master terminal [108](#)  
    physical terminal [108](#)  
    PRIMARY parameter [108](#)  
  master terminal [113](#)  
  NODE keyword [110](#)

ASSIGN command (*continued*)

- NOSAVE keyword [110](#)
- NPRI keyword
  - BMP transactions [110](#)
- OUTPUT keyword
  - description [110](#)
- PARLIM keyword
  - description [110](#)
- PLMCT keyword
  - description [111](#)
- PTERM keyword [111](#)
- REGION keyword [111](#)
- SAVE keyword [111](#)
- SEGNO keyword
  - description [111](#)
- SEGSIZE keyword
  - description [111](#)
- static terminals, using in [113](#)
- syntax [104](#)
- TRAN keyword [112](#)
- USER keyword [112](#)
- VTAM terminals, using in [114](#)
- VTAMPOOL keyword [112](#)

assignment changes

- losing when control blocks are deleted [110](#)

attributes

- DISPLAY command [501](#)

AUTOLOGON keyword

- DISPLAY USER command
  - examples [720](#)

automated operator interface (AOI) [29](#)

## B

BACKUP keyword

- ERESTART command [725](#)

BALGRP keyword

- DISPLAY command [653](#)

Base Primitive Environment (BPE)

- commands in CSL [23](#)

Batch SPOC

- format [10](#)

BKERR keyword

- DISPLAY command
  - description [562](#)

BMP (batch message processing) program

- no backout of updates [725](#)

BMP transactions

- ASSIGN command
  - NPRI keyword [110](#)
  - LPRI keyword [107](#)

BPE (Base Primitive Environment)

- commands in CSL [23](#)

BROADCAST command

- ACTIVE keyword [122](#)
- CHECKPOINT command [157](#)
- description [121](#)
- environment [121](#)
- examples [124](#)
- keywords [122](#)
- LINE keyword [123](#)
- LTERM keyword
  - ALL parameter [123](#)
  - description [123](#)

BROADCAST command (*continued*)

- MASTER parameter [123](#)
  - MSNAME keyword [123](#)
  - NODE keyword [123](#)
  - PTERM keyword [123](#)
  - syntax [121](#)
  - SYSID keyword [123](#)
  - usage notes [123](#)
  - USER keyword [123](#)
- BUILDQ keyword
- ERESTART command [725](#)

## C

CANCEL command

- description [127](#)
- environments [127](#)
- example [127](#)
- syntax [127](#)
- usage notes [127](#)

catalog, IMS

- IMPORT DEFN SOURCE(CATALOG) [777](#)

CBT (control block table) pool

- display abbreviations [634](#)
- DISPLAY POOL command [632](#)
- storage pool [632](#)

CCTL (coordinator controller)

- status [549](#)

CCTL keyword

CHANGE command

- ABORT [131](#)
- cctlname [131](#)
- COMMIT [131](#)
- prtkn [131](#)

DISPLAY command

- description [549](#)
- examples [551](#)

CHANGE command

- APPC keyword
  - description [129](#)
  - environment [129](#)
  - keywords [130](#)
  - syntax [130](#)
  - usage notes [130](#)

CCTL keyword

- description [130](#)
- environment [130](#)
- examples [131](#)
- keywords [131](#)
- syntax [131](#)

CPLOG keyword

- description [132](#)
- environment [132](#)
- keywords [132](#)
- syntax [132](#)

DESC keyword

- description [132](#)
- environment [133](#)
- keywords [133](#)
- syntax [133](#)
- usage notes [134](#)

description [129](#)

DIR MFS keyword

- description [134](#)

CHANGE command (*continued*)

- DIR MFS keyword (*continued*)
  - environment [135](#)
  - syntax [135](#)
  - usage notes [135](#)
- FDR keyword
  - description [135](#)
  - environment [135](#)
  - syntax [136](#)
  - usage notes [136](#)
- INTERVAL value [147](#)
- LINK keyword
  - description [136](#)
  - environment [136](#)
  - examples, ASR [139](#)
  - examples, TCP/IP links [138](#)
  - keywords [137](#)
  - syntax [137](#)
- NODE keyword
  - description [140](#)
  - environment [140](#)
  - examples [142](#)
  - keywords [141](#)
  - syntax [141](#)
- OUTBND keyword [130](#)
- SUBSYS keyword
  - description [143](#)
  - environment [144](#)
  - examples [144](#)
  - keywords [144](#)
  - syntax [144](#)
- SURV keyword
  - description [145](#)
  - environment [145](#)
  - examples [147](#)
  - keywords [146](#)
  - syntax [145](#)
  - usage notes [146](#)
- TIMEOUT keyword [130](#)
- TIMEOUT value [146](#)
- TRAN keyword
  - description [148](#)
  - environment [148](#)
  - examples [148](#)
  - keywords [148](#)
  - syntax [148](#)
- UOR keyword
  - description [149](#)
  - environment [149](#)
  - examples [150](#)
  - keywords [150](#)
  - syntax [150](#)
- USER keyword
  - AUTOLOGON [152](#)
  - description [151](#)
  - environment [151](#)
  - ID [152](#)
  - keywords [151](#)
  - LOGOND [152](#)
  - MODE [152](#)
  - NODENAME [152](#)
  - NOSAVE [152](#)
  - SAVE [152](#)
  - syntax [151](#)
- CHANGE LINK command
  - examples, ASR [139](#)
  - examples, TCP/IP links [138](#)
- CHECKPOINT command
  - ABDUMP keyword [154](#)
  - DBCTL (database control) [154](#)
  - description [153](#)
  - DUMPQ keyword [154](#)
  - environment [153](#)
  - examples [157](#)
  - FREEZE keyword [154](#)
  - LEAVEGR keyword [155](#)
  - LEAVEPLEX keyword [155](#)
  - NOCQSSHUT keyword [156](#)
  - notifying with the BROADCAST command [157](#)
  - PURGE keyword [154](#)
  - QUIESCE keyword [156](#)
  - shutdown
    - description [153](#)
    - simple checkpoint
      - description [153](#)
    - SNAPQ keyword [156](#)
    - statistics checkpoint
      - description [154](#)
    - STATISTICS keyword [156](#)
    - system messages [157](#)
    - usage notes [156](#)
- CHECKPOINT keyword
  - ERESTART command [725](#)
- CLASS keyword
  - /DISPLAY command
    - ACT [521](#)
    - ASSIGN command [106](#)
    - DISPLAY command [653](#)
- CLSDST command
  - description [159](#)
  - environment [159](#)
  - example [161](#)
  - FORCE keyword [160](#)
  - ISC node [160](#)
  - NODE keyword [160](#)
  - syntax [159](#)
  - usage notes [160](#)
  - USER keyword [160](#)
  - VTAM terminal [161](#)
- CMD call [29](#)
- CMDAUTH keyword
  - ERESTART command [725](#)
- CMDAUTHE keyword
  - ERESTART command [725](#)
- COLDBASE keyword
  - ERESTART command [725](#)
- COLDCOMM keyword
  - ERESTART command [725](#)
- COLDSYS keyword
  - ERESTART command [725](#)
- COMM macro
  - time stamp [11](#)
- command
  - ACTIVATE [99](#)
  - ALLOCATE [101](#)
  - alter IMS resources [26](#)
  - ASSIGN [103](#)
  - automated operator transaction [29](#)

command (*continued*)

- behavior in an IMSplex [23](#)
- BROADCAST [121](#)
- CANCEL [127](#)
- CHANGE [129](#)
- CHECKPOINT [153](#)
- choosing a master client [24](#)
- CLSDST [159](#)
- CMD call [29](#)
- COMPT [163](#)
- CQCHKPT [167](#)
- CQQUERY [169](#)
- CQSET [173](#)
- DBCTL [7](#), [85](#)
- DBDUMP command [329](#)
- DBRECOVERY command [335](#)
- DCCTL
  - list [89](#)
- DELETE
  - type-2 [345](#)
- DELETE command [343](#)
- DEQUEUE [451](#)
- DFSnnn message [11](#)
- DFSTCF LOAD [459](#)
- DIAGNOSE [461](#), [462](#)
- DISPLAY [499](#)
- END [723](#)
- ERESTART [725](#)
- ETO [97](#)
- EXCLUSIVE [735](#)
- EXIT [737](#)
- format
  - DBCTL [15](#)
- FORMAT command [769](#)
- HOLD [771](#)
- ICMD [31](#)
- IDLE [773](#)
- INITIATE [841](#)
- INITIATE OLREORG [879](#)
- input maximum length from z/OS consoles [5](#)
- keywords [15](#)
- LOCK [889](#)
- LOG [895](#)
- logged to secondary master terminal [28](#)
- LOOPTEST [897](#)
- LU 6.2 device
  - allocate conversation [7](#)
  - command response [12](#)
  - security defaults [39](#)
- maximum length input from z/OS consoles [5](#)
- mirrored on XRF alternate [35](#)
- MODIFY [899](#)
- MONITOR [905](#)
- MSASSIGN [907](#)
- MSVERIFY [911](#)
- multisegment input [5](#)
- OM security [34](#)
- OTMA security defaults [39](#)
- parameters [16](#)
- processing in a DRD environment [28](#)
- processing in an IMSplex [23](#)
- recovered at emergency [26](#)

command (*continued*)

- recovered at emergency restart [26](#)
- reserved words [16](#)
- response [11](#)
- response with EXCEPT phrase [11](#)
- status
  - emergency restart [27](#)
  - supported by AOI [29](#)
  - supported by OM API [40](#)
  - supported from LU 6.2 device [38](#)
  - supported from OTMA [38](#)
  - supported on the XRF alternate [36](#)
  - terminal security defaults [24](#)
  - transaction-entered [29](#)
- type-1
  - entering commands [1](#)
- type-2
  - entering commands [1](#)
- verb [15](#)
- z/OS
  - entering commands [1](#)
- command characteristics [24](#)
- command comments [19](#)
- command format
  - type-2 [20](#)
- command recognition character [15](#)
- command responses [12](#)
- command routing
  - IMSplex [23](#)
- commands
  - BPE [23](#)
  - equivalent IMS Connect WTOR, z/OS, and type-2 commands [52](#)
  - equivalent IMS type-1 and type-2 commands [43](#)
  - issuing
    - TSO SPOC [8](#)
  - issuing to the IMSplex [22](#)
  - not issued directly to OM [23](#)
  - prerequisite knowledge [ix](#)
- comment
  - command [19](#)
- COMMIT keyword
  - MODIFY Command [900](#)
- COMPONENT keyword
  - 3275 terminal [106](#)
  - 3770 terminal [107](#)
  - ASSIGN command [106](#)
  - SLU 1 terminal [107](#)
  - SLU 4 terminal [107](#)
  - SLU P terminal [107](#)
- COMPT command
  - description [163](#)
  - environment [163](#)
  - examples [165](#)
  - NOTRDY keyword [164](#)
  - parameters [164](#)
  - READY keyword [164](#)
  - ready state [165](#)
  - syntax [163](#)
  - usage notes [165](#)
- control block
  - application, cannot load [520](#)
  - IMS, deletion of affinities [155](#)
  - losing assignment changes when deleted [110](#)

control block (*continued*)  
 table (CBT) pools, defining [632](#)  
 terminal  
 specifying the logon descriptor [152](#)

CONV keyword  
 DISPLAY command  
 description [552](#)  
 example [554](#)

CONVERSATION keyword  
 EXIT command [738](#)

conversational processing  
 status [552](#)

CPI communications driven transactions  
 ASSIGN PARLIM command [110](#)  
 ASSIGN PLMCT command [111](#)  
 ASSIGN SEGNO command [111](#)

CPLOG  
 DISPLAY command [556](#)

CPLOG keyword  
 DISPLAY command  
 description [556](#)

CPRI keyword  
 ASSIGN command [107](#)

CQCHKPT command  
 description [167](#)  
 environment [167](#)  
 examples [168](#)  
 SHAREDQ keyword [167](#)  
 STRUCTURE keyword [167](#)  
 syntax [167](#)  
 SYSTEM keyword [167](#)  
 usage notes [168](#)

CQQUERY command  
 description [169](#)  
 environment [169](#)  
 examples [170](#)  
 keywords [169](#)  
 syntax [169](#)  
 usage notes [169](#)

CQS (Common Queue Server)  
 DISPLAY command [557](#)

CQS keyword  
 DISPLAY command  
 description [557](#)  
 examples [557](#)

CQSET command  
 description [173](#)  
 environment [173](#)  
 examples [174](#)  
 SHAREDQ keyword [173](#)  
 SHUTDOWN keyword [173](#)  
 STRUCTURE keyword [174](#)  
 syntax [173](#)  
 usage notes [174](#)

CREATE command  
 DB keyword  
 completion codes [179](#)  
 description [175](#)  
 environment [175](#)  
 examples [181](#)  
 keywords [176](#)  
 output fields [178](#)  
 reason codes [179](#)  
 return codes [179](#)

CREATE command (*continued*)  
 DB keyword (*continued*)  
 syntax [176](#)  
 usage notes [178](#)

DBDESC keyword  
 completion codes [186](#)  
 description [182](#)  
 environment [183](#)  
 examples [187](#)  
 keywords [183](#)  
 output fields [185](#)  
 reason codes [186](#)  
 return codes [186](#)  
 syntax [183](#)  
 usage notes [185](#)

IMS Connect  
 DATASTORE [188](#)

IMSCON keyword  
 description [188](#)

IMSCON TYPE(DATASTORE) keyword  
 completion codes [195, 196](#)  
 description [188](#)  
 environment [189](#)  
 equivalent WTOR and z/OS commands [194](#)  
 examples [196](#)  
 keywords [190](#)  
 output fields [194](#)  
 reason codes [195, 196](#)  
 return codes [195, 196](#)  
 syntax [189](#)  
 usage notes [194](#)

IMSCON TYPE(IMSPLEX) keyword  
 completion codes [201, 202](#)  
 description [198](#)  
 environment [199](#)  
 equivalent WTOR and z/OS commands [200](#)  
 examples [202](#)  
 keywords [199](#)  
 output fields [200](#)  
 reason codes [201, 202](#)  
 return codes [201, 202](#)  
 syntax [199](#)  
 usage notes [200](#)

IMSCON TYPE(PORT) keyword  
 completion codes [208, 210](#)  
 description [204](#)  
 environment [204](#)  
 equivalent WTOR and z/OS commands [207](#)  
 examples [210](#)  
 keywords [205](#)  
 output fields [207](#)  
 reason codes [208, 210](#)  
 return codes [208, 210](#)  
 syntax [205](#)  
 usage notes [207](#)

LTERM keyword  
 completion codes [215](#)  
 description [214](#)  
 environment [214](#)  
 examples [217](#)  
 keywords [214](#)

CREATE command (*continued*)

LTERM keyword (*continued*)

output fields [215](#)  
reason codes [215](#)  
return codes [215](#)  
usage notes [215](#)

MSLINK

description [218](#)

MSNAME keyword

completion codes [229](#)  
description [226](#)  
environment [226](#)  
examples [230](#)  
keywords [227](#)  
output fields [228](#)  
reason codes [228](#)  
return codes [228](#)  
usage notes [227](#)

MSPLINK keyword

completion codes [237](#)  
description [231](#)  
environment [231](#)  
example for CTC link type [240](#)  
example for MTM link type [241](#)  
example for TCPIP link type [242](#)  
example for VTAM link type [243](#)  
keywords [233](#)  
output fields [237](#)  
reason codes [237](#)  
return codes [237](#)  
syntax [232](#)  
usage notes [236](#)

OTMADESC keyword

completion codes [251](#)  
description [244](#)  
environment [244](#)  
examples [253](#)  
keywords [246](#)  
output fields [251](#)  
reason codes [251](#)  
return codes [251](#)  
syntax [245](#)  
usage notes [250](#)

PGM keyword

completion codes [260](#)  
description [254](#)  
environment [255](#)  
examples [263](#)  
keywords [256](#)  
output fields [260](#)  
reason codes [260](#)  
return codes [260](#)  
syntax [255](#)  
usage notes [259](#)

PGMDESC keyword

completion codes [271](#)  
description [265](#)  
environment [265](#)  
examples [273](#)  
keywords [266](#)  
output fields [270](#)  
reason codes [271](#)  
return codes [271](#)  
syntax [266](#)

CREATE command (*continued*)

PGMDESC keyword (*continued*)

usage notes [270](#)

RTC keyword

completion codes [277](#)  
description [274](#)  
environment [274](#)  
examples [278](#)  
keywords [275](#)  
output fields [276](#)  
reason codes [277](#)  
return codes [277](#)  
usage notes [276](#)

RTCDESC keyword

completion codes [283](#)  
description [280](#)  
environment [280](#)  
examples [285](#)  
keywords [281](#)  
output fields [282](#)  
reason codes [283](#)  
return codes [283](#)  
syntax [280](#)  
usage notes [282](#)

TRAN keyword

completion codes [301](#)  
description [285](#)  
environment [286](#)  
examples [306](#)  
keywords [288](#)  
output fields [301](#)  
reason codes [301](#)  
return codes [301](#)  
syntax [286](#)  
usage notes [300](#)

TRANDESC keyword

completion codes [323](#)  
description [307](#)  
environment [308](#)  
examples [327](#)  
keywords [310](#)  
output fields [323](#)  
reason codes [323](#)  
return codes [323](#)  
syntax [308](#)  
usage notes [322](#)

CREATE MSLINK command

completion codes [224](#)  
description [218](#)  
environment [218](#)  
examples [225](#)  
keywords [220](#)  
output fields [223](#)  
reason codes [223](#)  
return codes [223](#)  
syntax [218](#)  
usage notes [222](#)

**D**

data parameter

FORMAT command [770](#)

database

DBRC authorization



database (*continued*)
 

- DBRC authorization (*continued*)
  - MODIFY command [903](#)
- deleting
  - MODIFY command [903](#)
- Fast Path
  - MODIFY command [903](#)
- status [557](#)

database control [85](#)

DATABASE keyword
 

- DBDUMP command [330](#)

databases
 

- HALDB
  - INITIATE OLREORG command [878](#)
- reorganizing
  - INITIATE OLREORG command [878](#)

DATAGRP keyword
 

- DATAGRP command [336](#)

DB keyword
 

- DBRECOVERY command [336](#)
- DISPLAY command
  - description [557](#)
  - examples [563](#)
- DISPLAY command with BKERR keyword [562](#)
- LOCK command [890](#)

DBCTL (database control)
 

- CHECKPOINT command [154](#)
  - command
  - examples [7](#)
  - format [7](#)
  - list [85](#)
- DBDUMP command [330](#)
- DBRECOVERY command [337](#)
- LOCK DB command [890](#)

DBD keyword
 

- DISPLAY command
  - description [567](#)
- Fast Path [567](#)

DBDESC keyword [353](#)

DBDUMP command
 

- DATABASE keyword [330](#)
- DBCTL [330](#)
- description [329](#)
- environment [329](#)
- equivalent IMS type-2 commands [332](#)
- examples [332](#)
- GLOBAL keyword [330](#)
- keywords [329](#)
- LOCAL keyword [331](#)
- MSDB [330](#)
- NOFEOV keyword [331](#)
- NOPFA keyword [331](#)
- syntax [329](#)
- usage notes [331](#)

DBRC (database recovery control)
 

- DBRECOVERY command [337](#)

DBRECOVERY command
 

- AREA keyword [336](#)
- DATAGRP keyword [336](#)
- DB keyword [336](#)
- DBCTL [337](#)
- DBRC [337](#)
- DEDB [339](#)
- description [335](#)

DBRECOVERY command (*continued*)
 

- environment [335](#)
- equivalent IMS type-2 commands [340](#)
- examples [340](#)
- GLOBAL keyword [337](#)
- keywords [336](#)
- LOCAL keyword [338](#)
- MSDB [336](#)
- NOFEOV keyword [338](#)
- NOPFA keyword [338](#)
- syntax [335](#)
- usage notes [338](#)

DC keyword
 

- /DISPLAY command
  - ACT [515](#)
  - IDLE command [775](#)

DCCTL (data communication control)
 

- commands
  - list [89](#)

DEADQ status
 

- DEQUEUE USER command [456](#)

DEDB (data entry database)
 

- DBRECOVERY command [339](#)
- DISPLAY command [557](#)
- ERESTART command [725](#)
- LOCK DB command [890](#)

DEFN keyword [358](#)

DELETE command
 

- DB keyword
  - completion codes [347](#)
  - description [345](#), [346](#)
  - environment [345](#)
  - examples [351](#)
  - keywords [346](#)
  - output fields [347](#)
  - reason codes [347](#)
  - return codes [347](#)

DBDESC keyword
 

- completion codes [354](#)
- description [352](#)
- environment [353](#)
- examples [356](#)
- keywords [353](#)
- output fields [354](#)
- reason codes [354](#)
- return codes [354](#)
- usage notes [353](#)

DEFN keyword
 

- completion codes [365](#)
- description [358](#), [363](#)
- environment [358](#)
- examples [368](#)
- keywords [359](#)
- output fields [364](#)
- reason codes [365](#)
- return codes [365](#)

description [343](#)

environment [343](#)

IMSCON keyword
 

- description [375](#)

IMSCON TYPE(DATASTORE) keyword
 

- completion codes [377](#)
- description [375](#)
- environment [376](#)



DELETE command (*continued*)

IMSCON TYPE(DATASTORE) keyword (*continued*)

equivalent WTOR and z/OS commands  
[378](#)  
example [378](#)  
keywords [376](#)  
output fields [377](#)  
reason codes [377](#)  
return codes [377](#)  
syntax [375](#)  
usage notes [376](#)

IMSCON TYPE(IMSPLEX) keyword

completion codes [381](#)  
description [380](#)  
environment [380](#)  
equivalent WTOR and z/OS commands  
[382](#)  
example [383](#)  
keywords [380](#)  
output fields [381](#)  
reason codes [381](#)  
return codes [381](#)  
syntax [380](#)  
usage notes [381](#)

IMSCON TYPE(PORT) keyword

completion codes [386](#)  
description [384](#)  
environment [385](#)  
equivalent WTOR and z/OS commands  
[387](#)  
example [387](#)  
keywords [385](#)  
output fields [385](#)  
reason codes [386](#)  
return codes [386](#)  
syntax [384](#)  
usage notes [385](#)

keywords [343](#)

LE keyword

completion codes [391](#)  
description [389](#)  
environment [389](#)  
examples [392](#)  
keywords [390](#)  
output fields [391](#)  
reason codes [391](#)  
return codes [391](#)  
syntax [390](#)  
usage notes [390](#)

LTERM keyword

completion codes [398](#)  
description [395](#)  
environment [396](#)  
examples [399](#)  
keywords [396](#)  
output fields [397](#)  
reason codes [397](#)  
return codes [397](#)  
syntax [396](#)  
usage notes [396](#)

MSLINK keyword

completion codes [402](#)  
description [400](#)  
environment [400](#)

DELETE command (*continued*)

MSLINK keyword (*continued*)

examples [403](#)  
keywords [400](#)  
output fields [401](#)  
reason codes [402](#)  
return codes [402](#)  
syntax [400](#)  
usage notes [401](#)

MSNAME keyword

completion codes [407](#)  
description [404](#)  
environment [404](#)  
examples [408](#)  
keywords [405](#)  
output fields [406](#)  
reason codes [406](#)  
return codes [406](#)  
syntax [405](#)  
usage notes [405](#)

MSPLINK keyword

completion codes [412](#)  
description [410](#)  
environment [410](#)  
examples [413](#)  
keywords [410](#)  
output fields [411](#)  
reason codes [412](#)  
return codes [412](#)  
syntax [410](#)  
usage notes [411](#)

OTMADESC keyword

completion codes [416](#)  
description [414](#)  
environment [415](#)  
examples [417](#)  
keywords [415](#)  
output fields [415](#)  
reason codes [416](#)  
return codes [416](#)  
syntax [415](#)  
usage notes [415](#)

PGM keyword

completion codes [420](#)  
description [418](#)  
environment [418](#)  
examples [422](#)  
keywords [418](#)  
output fields [419](#)  
reason codes [420](#)  
return codes [420](#)  
syntax [418](#)  
usage notes [419](#)

PGMDESC keyword

completion codes [425](#)  
description [423](#)  
environment [423](#)  
examples [426](#)  
keywords [424](#)  
output fields [424](#)  
reason codes [425](#)  
return codes [425](#)  
syntax [423](#)  
usage notes [424](#)

DELETE command (*continued*)

RTC keyword  
completion codes [430](#)  
description [428](#)  
environments [428](#)  
examples [431](#)  
keywords [428](#)  
output fields [429](#)  
reason codes [430](#)  
return codes [430](#)  
syntax [428](#)  
usage notes [429](#)

RTCDESC keyword  
completion codes [434](#)  
description [432](#)  
environment [433](#)  
examples [436](#)  
keywords [433](#)  
output fields [434](#)  
reason codes [434](#)  
return codes [434](#)  
syntax [433](#)  
usage notes [433](#)

syntax [343](#)

TRAN keyword  
completion codes [440](#)  
description [437](#)  
environment [437](#)  
examples [442](#)  
keywords [438](#)  
output fields [439](#)  
reason codes [440](#)  
return codes [440](#)  
usage notes [438](#)

TRANDESC keyword  
completion codes [446](#)  
description [444](#)  
environment [444](#)  
examples [447](#)  
keywords [444](#)  
output fields [445](#)  
reason codes [446](#)  
return codes [446](#)  
syntax [444](#)  
usage notes [445](#)

type-2  
environment [389](#)  
LE keyword [390](#)  
requirement [391](#)  
syntax [390](#)  
usage [345](#)

DELETE LE command  
examples [392](#)

DEQUEUE command  
AOITOKEN keyword [452](#)  
description [451](#)  
environment [451](#)  
examples [456](#), [457](#)  
keywords [452](#)  
LINE keyword [452](#)  
LTERM keyword [452](#)  
LUNAME keyword [453](#)  
MSNAME keyword [453](#)  
network-qualified LU name [453](#)

DEQUEUE command (*continued*)

NODE keyword [453](#)  
PTERM keyword [452](#)  
PURGE keyword [454](#)  
PURGE1 keyword [454](#)  
SUSPEND keyword [454](#)  
TMEM keyword  
OTMA [455](#)  
TPIPE keyword  
OTMA [455](#)  
TPNAME keyword [453](#)  
TRAN keyword [455](#)  
usage nose [456](#)  
USER keyword [455](#)

DEQUEUE USER command  
DEADQ status [456](#)

DESC keyword  
CHANGE command  
LUNAME [133](#)  
MODE [134](#)  
OUTBND [134](#)  
SIDE [134](#)  
SYNCLLEVEL [134](#)  
TPNAME [134](#)  
TYPE [134](#)

DELETE command [343](#)

DISPLAY command  
description [568](#)  
example [569](#)

DFSCPIC

DISPLAY TRANSACTION command [707](#)

DFSTCF LOAD

description [459](#)

DIAGNOSE command

description [461](#), [462](#)  
environment [461](#), [462](#)  
example [462](#), [494](#)  
keywords [466](#)  
syntax [461](#), [463](#)

DISPLAY command

ACT keyword  
CLASS [521](#)  
DC [515](#)  
description [514](#)  
environments [514](#)  
examples [522](#)  
JOBNAME [517](#)  
OTMA GROUP [515](#)  
PROGRAM [518](#)  
REGID [517](#)  
REGION [515](#)  
STATUS [516](#), [518](#)  
syntax [514](#)  
TRANSACTION/STEP  
[517](#)  
TYPE [517](#)  
usage notes [515](#)  
VTAM ACB [515](#)

AFFIN keyword

description [529](#)  
environments [529](#)  
equivalent IMS type-2 commands [530](#)  
examples [530](#)  
output fields [532](#)

DISPLAY command (*continued*)

AFFIN keyword (*continued*)

syntax [529](#)  
usage notes [530](#)

AOITKN keyword

description [531](#)  
environment [531](#)  
examples [532](#)  
syntax [531](#)  
usage notes [531](#)

APPC keyword

description [532](#)  
environment [532](#)  
examples [534](#)  
output fields [533](#)  
syntax [532](#)

AREA keyword

description [534](#)  
environments [534](#)  
equivalent IMS type-2 commands [536](#)  
examples [538](#)  
output fields [536](#)  
syntax [535](#)  
usage notes [535](#)

ASMT keyword

description [540](#)  
environments [540](#)  
equivalent IMS type-2 commands [542](#)  
examples [543](#)  
syntax [540](#)

attributes

list [501](#)

BALGRP keyword [653](#)

BKERR keyword

description [562](#)

CCTL keyword

description [549](#)  
environments [549](#)  
examples [550](#)  
keywords [550](#)  
output fields [550](#)  
syntax [550](#)

CLASS keyword [653](#)

CONV keyword

description [552](#)  
environments [552](#)  
equivalent IMS type-2 commands [554](#)  
example [554](#)  
examples [554](#)  
output fields [554](#)  
syntax [552](#)  
usage notes [553](#)

conversation processing [553](#)

CPLOG keyword

description [556](#)  
environments [556](#)  
syntax [556](#)

CQS keyword

description [557](#)  
environments [557](#)  
examples [557](#)  
syntax [557](#)

DB keyword

description [557](#)

DISPLAY command (*continued*)

DB keyword (*continued*)

environments [558](#)  
equivalent IMS type-2 commands [560](#)  
examples [563](#)  
output fields [561](#)  
syntax [558](#)  
usage notes [560](#)

DBD keyword

description [567](#)  
environments [567](#)  
equivalent IMS type-2 commands [567](#)  
examples [567](#)  
syntax [567](#)

DESC keyword

description [568](#)  
environments [568](#)  
examples [569](#)  
output fields [568](#)  
syntax [568](#)

description [499](#)

FDR keyword

environments [569](#)  
examples [570](#)  
output fields [569](#)  
syntax [569](#)

FPV keyword

environments [570](#)  
examples [571](#)  
output fields [570](#)  
syntax [570](#)

HSSP keyword

description [572](#)  
environments [572](#)  
examples [573](#)  
output fields [573](#)  
syntax [572](#)

LINE keyword

description [574](#)  
environments [574](#)  
examples [577](#)  
keywords [575](#)  
reserved parameters [575](#)  
syntax [574](#)

LINK keyword

description [578](#)  
environments [578](#)  
examples [580](#)  
keywords [579](#)  
output fields [579](#)  
syntax [578](#)  
usage notes [579](#)

LTERM keyword

description [581](#)  
EMHQ [582](#)  
environments [582](#)  
equivalent IMS type-2 commands [583](#)  
examples [584](#)  
keywords [582](#)  
QCNT [582](#)  
syntax [582](#)  
usage notes [583](#)

LU keyword

environments [585](#)

DISPLAY command (*continued*)

LU keyword (*continued*)

examples [588](#)

syntax [586](#)

LUNAME keyword

description [585](#)

MASTER keyword

description [590](#)

environments [590](#)

equivalent IMS type-2 commands [591](#)

examples [591](#)

syntax [591](#)

MODIFY keyword

description [591](#)

environments [592](#)

equivalent IMS type-2 commands [594](#)

examples [598](#), [599](#)

keywords [592](#)

output fields [594](#)

syntax [592](#)

usage notes [594](#)

MSNAME keyword

description [603](#)

environments [603](#)

examples [604](#)

keywords [604](#)

syntax [604](#)

network-qualified LU name [532](#)

NODE keyword

description [605](#)

EMHQ [608](#)

environments [605](#)

equivalent IMS type-2 commands [610](#)

examples [611](#)

keywords [607](#)

MODE [608](#)

QCNT [608](#)

syntax [606](#)

usage notes [609](#)

OASN keyword

description [616](#)

examples [616](#)

OASN SUBSYS keyword

environments [616](#)

examples [616](#)

syntax [616](#)

OLDS keyword

description [617](#)

environments [617](#)

examples [619](#)

keywords [618](#)

syntax [617](#)

usage notes [618](#)

OTMA keyword

description [620](#)

environments [620](#)

examples [622](#)

output fields [621](#)

syntax [620](#)

OVERFLOWQ keyword

description [625](#)

environments [625](#)

examples [627](#)

keywords [626](#)

DISPLAY command (*continued*)

OVERFLOWQ keyword (*continued*)

output fields [626](#)

syntax [625](#)

usage notes [626](#)

parameters [657](#)

PGM keyword

description [628](#)

environments [628](#)

equivalent IMS type-2 commands [629](#)

examples [629](#)

syntax [628](#)

usage notes [629](#)

POOL keyword

abbreviations used [634](#)

CBT pool [632](#)

description [630](#)

environments [631](#)

equivalent IMS type-2 commands [634](#)

examples [640](#)

syntax [631](#)

usage notes [632](#)

PRIORITY keyword [653](#)

PSB keyword

description [648](#)

environments [649](#)

equivalent IMS type-2 commands [649](#)

examples [649](#)

syntax [649](#)

usage notes [649](#)

PTERM keyword

description [650](#)

environments [650](#)

examples [652](#)

syntax [650](#)

usage notes [651](#)

Q keyword

description [652](#)

environments [652](#)

examples [653](#)

keywords [653](#)

syntax [653](#)

QCNT keyword

description [656](#)

environments [656](#)

equivalent IMS type-2 commands [658](#)

examples [658](#)

output fields [658](#)

syntax [657](#)

usage notes [657](#)

RECOVERY keyword

description [660](#)

environments [660](#)

examples [663](#)

keywords [660](#)

output fields [662](#)

syntax [660](#)

usage notes [661](#)

RTC keyword

equivalent IMS type-2 commands [666](#)

RTCODE keyword

description [666](#)

environments [666](#)

examples [666](#)

DISPLAY command (*continued*)

RTCODE keyword (*continued*)  
syntax [666](#)

SHUTDOWN keyword  
description [667](#)  
examples [670](#)

SHUTDOWN STATUS keyword  
environments [667](#)  
examples [670](#)  
syntax [667](#)  
usage notes [667](#)

status  
list [501](#)

STATUS keyword  
description [667](#), [672](#)  
environments [672](#)  
equivalent IMS type-2 commands [674](#)  
examples [675](#)  
syntax [673](#)  
usage notes [673](#)

STRUCTURE keyword  
description [679](#)  
environments [679](#)  
examples [680](#)  
syntax [679](#)  
usage notes [679](#)

SUBSYS keyword  
description [616](#), [680](#)  
environments [681](#)  
examples [616](#), [682](#)  
syntax [681](#)  
usage notes [681](#)

SYSID keyword  
description [683](#)  
examples [684](#)

SYSID TRANSACTION keyword  
environments [683](#)  
examples [684](#)  
syntax [684](#)

TIMEOVER keyword  
description [684](#)  
environments [684](#)  
examples [685](#)  
keywords [684](#)  
syntax [684](#)  
usage notes [685](#)

TMEMBER keyword  
description [685](#)  
environments [685](#)  
examples [685](#)  
output fields [685](#), [688](#)  
syntax [685](#)  
usage notes [685](#)

TMEMBER QCNT keyword  
description [686](#)  
example [692](#)

TMEMBER TPIPE keyword  
description [686](#)  
output fields [685](#)

TMEMBER TPIPE OUTPUT keyword  
description [687](#)  
example [696](#)

TMEMBER TPIPE QCNT keyword  
description [687](#)

DISPLAY command (*continued*)

TMEMBER TPIPE QCNT keyword (*continued*)  
example [693](#)

TMEMBER TPIPE SYNC keyword  
description [687](#)

TRACE keyword  
description [697](#)  
environments [698](#)  
equivalent IMS type-2 commands [699](#)  
examples [701](#)  
keywords [699](#)  
output fields [700](#)  
syntax [698](#)  
usage notes [699](#)

TRAN keyword  
description [707](#)  
environments [707](#)  
equivalent IMS type-2 commands [709](#)  
examples [710](#)  
keywords [708](#)  
output fields [709](#)  
QCNT [708](#)  
syntax [708](#)  
usage notes [709](#)

TRANSACTION keyword  
with Q keyword [653](#)  
with SYSID keyword [683](#)

UOR keyword  
description [711](#), [712](#)  
environments [712](#)  
examples [713](#)  
output fields [712](#)  
syntax [712](#)

USER keyword  
description [715](#)  
environments [715](#)  
equivalent IMS type-2 commands [718](#)  
examples [719](#)  
keywords [716](#)  
syntax [715](#)  
usage notes [717](#)

DISPLAY NODE command

EMHQ keyword  
examples [615](#)  
QCNT keyword  
examples [615](#)

display screen format

display area [4](#)  
master terminal [2](#)  
master terminal in XRF [2](#)  
message area [3](#)  
system status [2](#)  
user input area [4](#)  
warning message area [4](#)  
XRF system status [2](#)

DISPLAY USER command

AUTOLOGON keyword  
examples [720](#)  
EMHQ keyword  
examples [720](#)  
QCNT keyword  
examples [720](#)

DL/I

database error queues

DL/I (continued)  
  database error queues (continued)  
    status [562](#)  
DL/I databases  
  inflight changes  
    backing out [725](#)  
DUMPQ keyword  
  CHECKPOINT command [154](#)

## E

E-MCS 4  
EMHQ keyword  
  /DISPLAY command  
    LTERM [582](#)  
    NODE [608](#)  
  DISPLAY NODE command  
    examples [615](#)  
  DISPLAY USER command  
    examples [720](#)  
END command  
  description [723](#)  
  environment [723](#)  
  example [724](#)  
  keywords [723](#)  
  LINE keyword [723](#)  
  NODE keyword [723](#)  
  PTERM keyword [723](#)  
  syntax [723](#)  
  usage notes [724](#)  
  USER keyword [724](#)  
Entry Terminal (ET) [14](#)  
environments, valid for keywords  
  /ASSIGN command [103](#)  
EOM  
  multisegment command input [5](#)  
EOS  
  multisegment command input [5](#)  
ERESTART command  
  BUILDQ keyword [725](#)  
  CHECKPOINT keyword [725](#)  
  CMDAUTH keyword [725](#)  
  CMDAUTHE keyword [725](#)  
  COLDBASE keyword [725](#)  
  COLDCOMM keyword [725](#)  
  COLDSYS keyword [725](#)  
  DEDB [725](#)  
  description [725](#)  
  environment [725](#)  
  example [725](#)  
  FORMAT keyword [725](#)  
  keywords [725](#)  
  MSDB [725](#)  
  MULTSIGN keyword [725](#)  
  NOBMP keyword [725](#)  
  NOCMDAUTH keyword [725](#)  
  NOCMDAUTHE keyword [725](#)  
  NOTRANAUTH keyword [725](#)  
  NOUSER keyword [725](#)  
  OVERRIDE keyword [725](#)  
  restart  
    security definition [725](#)  
  SNGLSIGN keyword [725](#)  
  syntax [725](#)

ERESTART command (continued)  
  TRANAUTH keyword [725](#)  
  usage notes [725](#)  
  USER keyword [725](#)  
ET (Entry Terminal)  
  response [14](#)  
ETO  
  commands [97](#)  
  terminal  
    ERESTART CMDAUTH command [725](#)  
    ERESTART CMDAUTHE command [725](#)  
examples  
  /DISPLAY ACT command [522](#)  
  /DISPLAY AFFIN command [530](#)  
  /DISPLAY AOITKN command [532](#)  
  /DISPLAY APPC command [534](#)  
  /DISPLAY FDR command [570](#)  
  /DISPLAY FPV command [571](#)  
  DELETE LE command [392](#)  
  TSO SPOC [14](#)  
EXCEPT phrase  
  response to command [11](#)  
EXCLUSIVE command  
  description [735](#)  
  environment [735](#)  
  example [736](#)  
  keywords [735](#)  
  LINE keyword [735](#)  
  NODE keyword [735](#)  
  PTERM keyword [735](#)  
  syntax [735](#)  
  usage notes [736](#)  
  USER keyword [736](#)  
EXIT command  
  CONVERSATION keyword [738](#)  
  description [737](#)  
  environment [737](#)  
  examples [739](#)  
  keywords [738](#)  
  LINE keyword [738](#)  
  LUNAME keyword [738](#)  
  NODE keyword [738](#)  
  PTERM keyword [738](#)  
  syntax [737](#)  
  TMEMBER TPIPE keyword [738](#)  
  usage notes [738](#)  
  USER keyword [738](#)  
EXPORT command  
  completion codes [752](#)  
  description [741](#)  
  environment [741](#)  
  examples [757](#)  
  keywords [743](#)  
  output fields [751](#)  
  reason codes [752](#)  
  return codes [752](#)  
  syntax [741](#)  
  usage notes [749](#)  
Extended Recovery Facility [2](#)

## F

Fast Path  
  area

Fast Path (*continued*)  
 area (*continued*)  
   status [534](#)  
 database  
   MODIFY command [903](#)  
 database buffer pool  
   display [639](#)  
 DEDBs  
   recovering [725](#)  
 DISPLAY DBD command [567](#)  
 ERESTART COLDBASE command [725](#)  
 exclusive transactions  
   DISPLAY command [707](#)  
 LOCK TRAN command [891](#)  
 FDR keyword  
   DISPLAY command [569](#)  
 FORCE keyword  
   CLSDST command [160](#)  
 format  
   lost during conversation  
   restoring [770](#)  
 FORMAT command  
   data parameter [770](#)  
   description [769](#)  
   environment [769](#)  
   example [770](#)  
   keywords [769](#)  
   LTERM keyword [769](#)  
   modname parameter [769](#)  
   syntax [769](#)  
   usage notes [770](#)  
 FORMAT keyword  
   ERESTART command [725](#)  
 FPV keyword  
   DISPLAY command [570](#)  
 FREEZE keyword  
   CHECKPOINT command [154](#)

## G

generic resources  
   affinity  
     displaying [529](#)  
 GLOBAL keyword  
   DBDUMP command [330](#)  
   DBRECOVERY command [337](#)

## H

HALDB  
   example  
     /DISPLAY DB command [565](#)  
     /DISPLAY DB Command [565](#)  
   reorganizing  
     INITIATE OLREORG command [878](#)  
 HOLD command  
   description [771](#)  
   environment [771](#)  
   example [771](#)  
   syntax [771](#)  
   usage notes [771](#)  
 HSSP (high-speed sequential processing)  
   status [572](#)

HSSP keyword  
   DISPLAY command  
     description [572](#)  
     example [573](#)

## I

IAM command  
   password [19](#)  
 ICMD call [31](#)  
 ICOMPONENT keyword  
   ASSIGN command [107](#)  
 IDLE command  
   DC keyword [775](#)  
   description [773](#)  
   environment [773](#)  
   examples [775](#)  
   keywords [774](#)  
   LINE keyword [774](#)  
   LINK keyword [774](#)  
   NODE keyword [775](#)  
   NOSHUT keyword  
     description [774](#)  
     restarting [774](#)  
   syntax [773](#)  
 IMPORT command  
   ACBs [777](#)  
   catalog  
     completion codes [787](#)  
     environment [778](#)  
     examples [797](#)  
     keywords [779](#)  
     output fields [783](#)  
     reason codes [785](#)  
     return codes [785](#)  
     syntax [778](#)  
     usage notes [781](#)  
   completion codes [785](#)  
   DBDs [777](#)  
   DRD [803](#)  
   examples [826](#)  
   IMS catalog [777](#)  
   IMSRSC repository [803](#)  
   MODBLKS resources [803](#)  
   PSBs [777](#)  
   RDDS  
     completion codes [815](#)  
     environment [803](#)  
     keywords [805](#)  
     output fields [811](#)  
     reason codes [812](#)  
     return codes [812](#)  
     syntax [804](#)  
     usage notes [809](#)  
   REPO  
     completion codes [815](#)  
     environment [803](#)  
     keywords [805](#)  
     output fields [811](#)  
     reason codes [812](#)  
     return codes [812](#)  
     syntax [804](#)  
     usage notes [809](#)  
   repository [803](#)



IMPORT command (*continued*)  
 resource definition data set [803](#)  
 SOURCE(CATALOG)  
 completion codes [787](#)  
 environment [778](#)  
 examples [797](#)  
 keywords [779](#)  
 output fields [783](#)  
 reason codes [785](#)  
 return codes [785](#)  
 syntax [778](#)  
 usage notes [781](#)  
 SOURCE(RDDS)  
 completion codes [815](#)  
 environment [803](#)  
 keywords [805](#)  
 output fields [811](#)  
 reason codes [812](#)  
 return codes [812](#)  
 syntax [804](#)  
 usage notes [809](#)  
 SOURCE(REPO)  
 completion codes [815](#)  
 environment [803](#)  
 keywords [805](#)  
 output fields [811](#)  
 reason codes [812](#)  
 return codes [812](#)  
 syntax [804](#)  
 usage notes [809](#)

IMS catalog  
 IMPORT DEFN SOURCE(CATALOG) [777](#)

IMS Command  
 entering  
 MCS [4](#)

IMS commands  
 entering  
 Batch SPOC [10](#)  
 LU 6.2 device [7](#)  
 Master Terminal Format [2](#)  
 TSO SPOC [8](#)  
 OM API [8](#)  
 supported by OM API  
 long form [40](#)  
 short form [40](#)  
 type-2 [20](#)

IMS Connect  
 CREATE IMSCON TYPE(DATASTORE) [188](#)  
 DATASTORE definition  
 CREATE IMSCON command [188](#)

IMSplex  
 command processing [23](#)  
 command routing [23](#)  
 issuing commands to [22](#)

IMSRSC repository  
 IMPORT DEFN SOURCE(REPO | RDDS) command [803](#)

INITIATE command  
 OLC keyword  
 completion codes [852](#)  
 description [841](#)  
 environment [841](#)  
 examples [866](#)  
 keywords [842](#)  
 output fields [850](#)

INITIATE command (*continued*)  
 OLC keyword (*continued*)  
 reason codes [852](#)  
 return codes [852](#)  
 syntax [842](#)  
 usage notes [848](#)  
 OLREORG keyword  
 completion codes [882](#)  
 description [878](#)  
 environment [878](#)  
 examples [885](#)  
 keywords [879](#)  
 output fields [882](#)  
 reason codes [882](#)  
 return codes [882](#)  
 syntax [878](#)  
 usage notes [881](#)

INITIATE OLC command  
 completion codes [858](#)  
 error handling [875](#)  
 keywords  
 OPTION [842](#)  
 PHASE [844](#)  
 TYPE [846](#)  
 return and reason codes [852](#)

INITIATE OLC PHASE(COMMIT) command [848](#)  
 INITIATE OLC PHASE(PREPARE) command [848](#)  
 INITIATE OLREORG command  
 completion codes [883](#)  
 keywords  
 NAME [879](#)  
 OPTION [879](#)  
 SET [879](#)  
 output fields [882](#)  
 responses [881](#)  
 return and reason codes [882](#)

INPUT keyword  
 ASSIGN command [107](#)

input, maximum length from z/OS consoles [5](#)

INTERVAL value  
 CHANGE command [147](#)

ISC (Intersystem Communication)  
 END NODE command [724](#)  
 node  
 ASSIGN OUTPUT command [110](#)  
 CLSDST command [160](#)  
 user  
 CLSDST NODE USER command [160](#)

## J

JOBNAME keyword  
 /DISPLAY command  
 ACT [517](#)

## K

keyboard shortcuts [xi](#)  
 KEYWD macro statement  
 ALL parameter [16](#)  
 generic parameters [17](#)  
 keyword  
 guidelines for entering [15](#)



keyword (*continued*)  
reserved words [93](#)  
synonyms [59](#)

keywords  
NAME [879](#)  
OPTION [879](#)  
SET [879](#)  
supported by OM API [40](#)

## L

LEAVEGR keyword  
CHECKPOINT command [155](#)

LEAVEPLEX keyword  
CHECKPOINT command [155](#)

legal notices  
notices [915](#)  
trademarks [915](#), [916](#)

library status information [594](#)

line  
inclusive parameter [16](#)

LINE keyword  
ASSIGN command [107](#)  
BROADCAST command [123](#)  
DEQUEUE command [452](#)  
DISPLAY command  
description [574](#)  
example [577](#)  
END command [723](#)  
EXCLUSIVE command [735](#)  
EXIT command [738](#)  
IDLE command [774](#)  
LOOPTEST command [897](#)  
MONITOR command [905](#)

link  
inclusive parameter [16](#)  
status [578](#)

LINK keyword  
ACTIVATE command [99](#)  
CHANGE command  
ASR [137](#)  
COLDSESS [137](#)  
FORCSESS [137](#)  
MODE [138](#)  
SYNCSESS [137](#)  
DISPLAY command  
description [578](#)  
examples [580](#)  
IDLE command [774](#)  
MSASSIGN command [908](#)

LMCT keyword  
ASSIGN command [107](#)

LOCAL keyword  
DBDUMP command [331](#)  
DBRECOVERY command [338](#)  
MSASSIGN command [908](#)

LOCK command  
DB keyword [890](#)  
description [889](#)  
environment [889](#)  
equivalent IMS type-2 commands [892](#)  
examples [892](#)  
keywords [890](#), [895](#)  
LTERM keyword [890](#)

LOCK command (*continued*)  
NODE keyword [890](#)  
password [19](#)  
PGM keyword [890](#)  
PTERM keyword [890](#)  
syntax [889](#)  
TRAN keyword [890](#)  
usage notes [891](#)

LOG command  
description [895](#)  
environment [895](#)  
example [895](#)  
syntax [895](#)

logical link path  
queue counts [603](#)

LOOPTEST command  
description [897](#)  
environment [897](#)  
example [898](#)  
LINE keyword [897](#)  
PTERM keyword [897](#)  
syntax [897](#)

looptest mode  
DISPLAY LINE PTERM command [897](#)

LPRI keyword  
ASSIGN command [107](#)  
BMP transactions [107](#)

lterm  
status [581](#)  
LTERM control block  
preventing deletion of [111](#)

LTERM keyword  
/DISPLAY command  
EMHQ [582](#)  
QCNT [582](#)  
ASSIGN command  
data considerations [109](#)  
description [107](#)  
master terminal [108](#)  
physical terminal [108](#)  
PRIMARY parameter [108](#)

BROADCAST command  
ALL parameter [123](#)  
description [123](#)  
DELETE type-2 command [390](#)  
DEQUEUE command [452](#)  
DISPLAY command  
description [581](#)  
examples [584](#)  
FORMAT command [769](#)  
LOCK command [890](#)

LU 6.2 application program  
DEALLOCATE [739](#)  
descriptor [568](#)  
ending conversations [739](#)  
EXIT command [739](#)  
network-qualified LU name  
status [568](#)  
status  
related activity [532](#)  
specific device [585](#)  
LU 6.2 device  
allocating a synchronous conversation [7](#)  
command

- LU 6.2 device (*continued*)
  - command (*continued*)
    - examples [7](#)
    - format [7](#)
    - response [12](#)
    - security defaults [39](#)
    - supported [38](#)
  - multisegment command input [5](#)
- LU keyword
  - DISPLAY command
    - examples [588](#)
- LUNAME keyword
  - ALLOCATE command [101](#)
  - DEQUEUE command [453](#)
  - DISPLAY command
    - description [585](#)
  - EXIT command [738](#)
  - network-qualified LU name [453](#)

## M

- MASTER parameter
  - BROADCAST command [123](#)
  - DISPLAY command
    - description [590](#)
    - examples [591](#)
- master terminal
  - ASSIGN command [113](#)
  - display screen [2](#)
  - display screen format [2](#)
  - entering commands [2](#)
  - messages to [13](#)
  - status [590](#)
  - XRF display screen format [2](#)
- Master Terminal (MT) [14](#)
- maximum length of command input from z/OS consoles [5](#)
- MCS (multiple console support) console [4](#)
- message
  - destination
    - CHANGE DESCRIPTOR command [134](#)
- Message Requeuer program [725](#)
- messages
  - sending
    - Master Terminal (MT) [13](#)
    - restrictions [13](#)
- MFS (Message Format Service)
  - bypass [31](#)
  - FORMAT command [770](#)
  - password [19](#)
- MODE keyword
  - /DISPLAY command
    - NODE [608](#)
  - ALLOCATE command [101](#)
- MODIFY command
  - ABORT keyword [900](#)
  - COMMIT keyword [900](#)
  - description [899](#)
  - environment [899](#)
  - examples [903](#)
  - keywords [900](#)
  - PREPARE keyword [901](#)
  - RACF keyword [902](#)
  - syntax [899](#)
  - usage notes [902](#)

- MODIFY keyword
  - DISPLAY command
    - description [591](#)
    - examples [599](#)
- modname parameter
  - FORMAT command [769](#)
- MONITOR command
  - description [905](#)
  - environment [905](#)
  - example [905](#)
  - keywords [905](#)
  - LINE keyword [905](#)
  - PTERM keyword [905](#)
- MRQ (Message Requeuer program)
  - ERESTART BUILDQ command [725](#)
- MSASSIGN command
  - description [907](#)
  - environment [907](#)
  - equivalent IMS type-2 commands [909](#)
  - examples [909](#)
  - keywords [908](#)
  - LINK keyword [908](#)
  - LOCAL keyword [908](#)
  - MSNAME keyword [908](#)
  - MSPLINK keyword [908](#)
  - syntax [907](#)
  - SYSID keyword [908](#)
  - TRAN keyword [908](#)
  - usage notes [909](#)
- MSC (Multiple Systems Coupling)
  - MSASSIGN command [909](#)
  - MSVERIFY command [911](#)
- MSDB (main storage database)
  - DBDUMP command [330](#)
  - DBRECOVERY command [336](#)
  - ERESTART command [725](#)
  - LOCK DB command [890](#)
  - reloading [725](#)
- MSNAME keyword
  - BROADCAST command [123](#)
  - DEQUEUE command [453](#)
  - DISPLAY command
    - description [603](#)
    - examples [604](#)
  - MSASSIGN command [908](#)
  - MSVERIFY command [911](#)
- MSPLINK keyword
  - DISPLAY command [542](#)
  - MSASSIGN command [908](#)
- MSVERIFY command
  - description [911](#)
  - environment [911](#)
  - examples [912](#)
  - keywords [911](#)
  - MSNAME keyword [911](#)
  - syntax [911](#)
  - SYSID keyword [911](#)
  - usage notes [911](#)
- MT (Master Terminal)
  - response [14](#)
- multiple console support [4](#)
- multisegment command input
  - 3270 Information Display System [5](#)
  - display screen [4](#)

multisegment command input (*continued*)

- EOM [5](#)
  - EOS [5](#)
  - examples [5](#)
  - LU 6.2 device [5](#)
- MULTISIGN keyword
- ERESTART command [725](#)

## N

- network-qualified LU name [8](#)
- NOBMP keyword
- ERESTART command [725](#)
- NOCMDAUTH keyword
- ERESTART command [725](#)
- NOCMDAUTHE keyword
- ERESTART command [725](#)
- NOCQSSHUT keyword
- CHECKPOINT command [156](#)
- node
- status [605](#)
- NODE keyword
- /DISPLAY command
    - EMHQ keyword [608](#)
    - MODE [608](#)
    - QCNT [608](#)
- ACTIVATE command [99](#)
- ASSIGN command [110](#)
- BROADCAST command [123](#)
- CHANGE command
- ASR [141](#)
  - COLDSESS [141](#)
  - FORCSESS [142](#)
  - MODE [142](#)
  - SYNCSESS [142](#)
  - USER [142](#)
- CLSDST command [160](#)
- DEQUEUE command [453](#)
- DISPLAY command
- description [605](#)
  - examples [611](#)
- END command [723](#)
- EXCLUSIVE command [735](#)
- EXIT command [738](#)
- IDLE command [775](#)
- LOCK command [890](#)
- NOFEOV keyword
- DBDUMP command [331](#)
  - DBRECOVERY command [338](#)
- non-VTAM lines
- terminate input
    - IDLE LINE NOSHUT command [774](#)
- NOPFA keyword
- DBDUMP command [331](#)
  - DBRECOVERY command [338](#)
- NOSAVE keyword
- ASSIGN command [110](#)
- NOSHUT keyword
- IDLE command
    - description [774](#)
    - restarting [774](#)
- NOTRANAUTH keyword
- ERESTART command [725](#)
- NOTRDY keyword

- NOTRDY keyword (*continued*)
- COMPT command [164](#)
- NOUSER keyword
- ERESTART command [725](#)
- NPRI keyword
- ASSIGN command
    - BMP transactions [110](#)
- null keywords [19](#)
- null word
- reserved words [93](#)

## O

- OASN (origin application schedule numbers)
- status [616](#)
- OASN keyword
- DISPLAY command
    - description [616](#)
    - examples [616](#)
- OLDS keyword
- DISPLAY command
    - description [617](#)
    - examples [619](#)
- OM (Operations Manager) [24](#)
- OM API
- command example [15](#)
  - command responses [12](#)
  - input [15](#)
  - issuing
    - commands [8](#)
    - output [15](#)
    - supported command long form [40](#)
    - supported command short form [40](#)
    - supported commands [40](#)
    - supported keywords [40](#)
- OM security [34](#)
- Open Transaction Manager Access (OTMA)
- status [620](#)
- Operations Manager (OM)
- choosing a master client [24](#)
  - supported command long form [40](#)
  - supported command short form [40](#)
  - supported commands [40](#)
- OSAM (overflow sequential access method)
- buffer pool
    - /DISPLAY POOL command [636](#)
- enhanced buffer pool
    - /DISPLAY POOL command [637](#)
- OTMA
- security default commands [39](#)
  - supported commands [38](#)
- OTMA GROUP keyword
- /DISPLAY command
    - ACT [515](#)
- OTMA keyword
- DISPLAY command
    - description [620](#)
- OUTBND keyword
- CHANGE command [130](#)
- OUTPUT keyword
- ASSIGN command
    - description [110](#)
- outstanding reply numbers
- z/OS system console [5](#)

OVERFLOWQ keyword  
  DISPLAY command  
    description [625](#)  
    examples [627](#)  
OVERRIDE keyword  
  ERESTART command [725](#)

## P

parameters  
  ALL [16](#)  
  description [16](#)  
  generic [17](#), [21](#)  
  group [18](#)  
  inclusive [16](#)  
PARLIM keyword  
  ASSIGN command  
    description [110](#)  
password  
  command [19](#)  
  definition [19](#)  
  RACF [19](#)  
  terminals [19](#)  
performance  
  checkpointing the queue structure [167](#)  
  displaying global queue information [658](#)  
  records [156](#)  
  serial search [17](#), [22](#)  
  when using /CQCHKPT [167](#)  
  when using /DISPLAY ALL [535](#)  
  when using /DISPLAY QCNT [658](#)  
PGM keyword  
  DELETE type-2 command [390](#)  
  DISPLAY command  
    description [628](#)  
    examples [629](#)  
  LOCK command [890](#)  
PHIDAM  
  example  
    /DISPLAY DB command [565](#)  
PLMCT keyword  
  ASSIGN command  
    description [111](#)  
POOL keyword  
  DISPLAY command  
    description [630](#)  
    examples [640](#)  
PREPARE keyword  
  MODIFY command [901](#)  
preset mode  
  3270 Information Display System  
    MFS bypass [31](#)  
  ASSIGN command  
    LINE keyword [107](#)  
    LTERM keyword [108](#)  
    NODE keyword [110](#)  
PRIORITY keyword  
  DISPLAY command [653](#)  
PROGRAM keyword  
  /DISPLAY command  
    ACT [518](#)  
PSB keyword  
  DISPLAY command  
    description [648](#)

PSB keyword (*continued*)  
  DISPLAY command (*continued*)  
    examples [649](#)  
pterm  
  inclusive parameter [16](#)  
PTERM keyword  
  ASSIGN command [111](#)  
  BROADCAST command [123](#)  
  DEQUEUE command [452](#)  
  DISPLAY command  
    description [650](#)  
    examples [652](#)  
  EXCLUSIVE command [735](#)  
  EXIT command [738](#)  
  LOCK command [890](#)  
  LOOPTEST command [897](#)  
  MONITOR command [905](#)  
PURGE keyword  
  CHECKPOINT command [154](#)  
  DEQUEUE command [454](#)  
PURGE1 keyword  
  DEQUEUE command [454](#)

## Q

Q keyword  
  DISPLAY command  
    description [652](#)  
    examples [653](#)  
QCNT keyword  
  /DISPLAY command  
    LTERM [582](#)  
    NODE [608](#)  
    TRANSACTION [708](#)  
  DISPLAY command  
    description [656](#)  
    examples [658](#)  
  DISPLAY NODE command  
    examples [615](#)  
  DISPLAY USER command  
    examples [720](#)  
QUIESCE keyword  
  CHECKPOINT command [156](#)

## R

RACF (Resource Access Control facility)  
  MODIFY RACF command [902](#)  
  password [19](#)  
RACF keyword  
  MODIFY command [902](#)  
RCF= parameter  
  overriding with ERESTART COLDSYS command [725](#)  
RDDS (resource definition data set)  
  IMPORT DEFN SOURCE(REPO | RDDS) command [803](#)  
READY keyword  
  COMPT command [164](#)  
ready state  
  COMPT command [165](#)  
RECOVERY keyword  
  DISPLAY command  
    description [660](#)  
REGID keyword

- REGID keyword (*continued*)
  - /DISPLAY command
    - ACT [517](#)
- REGION keyword
  - /DISPLAY command
    - ACT [515](#)
    - ASSIGN command [111](#)
- reorganization
  - INITIATE OLREORG command [878](#)
- reserved words
  - description [16](#)
  - keywords [15](#), [93](#)
  - null keywords [19](#)
  - null words [93](#)
  - parameters [93](#)
- RESET command
  - MFS bypass [31](#)
- resource definition data set (RDDS)
  - IMPORT DEFN SOURCE(REPO | RDDS) command [803](#)
- Resource Manager (RM)
  - command behavior [23](#)
- resources
  - assignment
    - status [540](#)
  - changed status [591](#)
- Response Terminal (RT) [14](#)
- restart
  - security definition [725](#)
- restriction
  - /ASSIGN command [113](#)
  - command status in emergency restart [27](#)
  - shutdown checkpoint in shared-queues environment [154](#)
- RM (Resource Manager) [23](#)
- RT (Response Terminal)
  - response [14](#)
- RTC keyword [275](#)
- RTCODE keyword
  - DISPLAY command
    - description [666](#)
    - examples [666](#)

## S

- SAVE keyword
  - ASSIGN command [111](#)
- secondary master terminal
  - commands logged [28](#)
- security
  - definition
    - at restart [725](#)
  - OM [34](#)
  - terminal default [24](#)
- SEGNO keyword
  - ASSIGN command
    - description [111](#)
- SEGSIZE keyword
  - ASSIGN command
    - description [111](#)
- serial search
  - performance [17](#), [22](#)
- SET keyword
  - /DIAGNOSE command [461](#)
- SGN= parameter

- SGN= parameter (*continued*)
  - overriding with ERESTART COLDSYS command [725](#)
- SHAREDQ keyword
  - CQCHKPT command [167](#)
  - CQSET command [173](#)
- shutdown
  - CHECKPOINT command
    - FREEZE keyword [155](#)
    - restriction in shared-queues environment [154](#)
    - status [667](#)
- SHUTDOWN keyword
  - CQSET command [173](#)
  - DISPLAY command
    - description [667](#)
    - examples [670](#)
- single point of control (SPOC)
  - sending commands with [22](#)
- SLU 1 terminal
  - COMPONENT keyword [107](#)
- SLU 4 terminal
  - COMPONENT keyword [107](#)
- SLU P terminal
  - COMPONENT keyword [107](#)
- SMCOPY command
  - commands logged to secondary master terminal [28](#)
- SNAP keyword
  - /DIAGNOSE command
    - ADDRESS [466](#)
    - AREA [466](#)
    - BLOCK [467](#)
    - DB [470](#)
    - LINE [472](#)
    - LINK [474](#)
    - LTERM [476](#)
    - MODULE [479](#)
    - MSNAME [479](#)
    - NODE [482](#)
    - OPTION [484](#)
    - PGM [485](#)
    - REGION [487](#)
    - STRUCTURE [491](#)
    - TRAN [491](#)
    - USER [491](#)
- SNAPQ keyword
  - CHECKPOINT command [156](#)
- SNGLSIGN keyword
  - ERESTART command [725](#)
- SPOC (single point of control)
  - sending commands with [22](#)
- static
  - node
    - inclusive parameter [16](#)
  - terminal
    - ERESTART CMDAUTH command [725](#)
- STATISTICS keyword
  - CHECKPOINT command [156](#)
  - CQQUERY command [169](#)
- status
  - active system [514](#)
  - CCTL [549](#)
  - communication line [574](#)
  - conversational processing [552](#)
  - database [557](#)
  - database access [567](#)

status (*continued*)  
 DEDB [557](#)  
 DISPLAY command  
   list [501](#)  
 DL/I database error queues [562](#)  
 external subsystem [680](#)  
 Fast Path  
   area [534](#)  
   database [673](#)  
   routing code [666](#)  
 HSSP activities [572](#)  
 IMS resources [672](#)  
 logical link [578](#)  
 logical link path [603](#)  
 logical terminal [581](#)  
 LU 6.2 application program  
   descriptor [568](#)  
   for specific devices [585](#)  
   related activities [532](#)  
 master terminal [590](#)  
 message queues [653](#)  
 node [605](#)  
 OASN [616](#)  
 OTMA [620](#)  
 OTMA target member [685](#)  
 physical terminal [574](#), [650](#)  
 program [628](#)  
 PSB [648](#)  
 resource assignment [540](#)  
 resources  
   added, changed, or deleted [591](#)  
 shutdown [667](#)  
 storage pools [630](#)  
 system logging [617](#)  
 trace [697](#)  
 transaction [683](#), [707](#)  
 unit of recovery [711](#)  
 user structures [715](#)  
 VTAM response [684](#)  
 STATUS keyword  
   /DISPLAY command  
     ACT [516](#), [518](#)  
   DISPLAY command  
     description [667](#), [672](#)  
     examples [675](#)  
 status, library information [594](#)  
 storage pool  
   status [630](#)  
 STRUCTURE keyword  
   CQCHKPT command [167](#)  
   CQQUERY command [169](#)  
   CQSET command [174](#)  
   DISPLAY command  
     description [679](#)  
     examples [680](#)  
 SUBSYS keyword  
   DISPLAY command  
     description [680](#)  
     examples [616](#), [682](#)  
 SURVEILLANCE keyword  
   CHANGE command  
     ALL [146](#)  
     INTERVAL [146](#)  
     LNK [146](#)

SURVEILLANCE keyword (*continued*)  
   CHANGE command (*continued*)  
     LOG [146](#)  
     RDS [146](#)  
     TIMEOUT [146](#)  
 SUSPEND keyword  
   DEQUEUE command [454](#)  
 syntax [275](#), [346](#), [353](#), [358](#), [438](#), [451](#), [905](#)  
 syntax diagram  
   how to read [ix](#)  
 SYSID keyword  
   BROADCAST command [123](#)  
   DISPLAY command  
     description [683](#)  
     examples [684](#)  
   MSASSIGN command [908](#)  
   MSVERIFY command [911](#)  
 system initialization parameters, displayed [725](#)  
 SYSTEM keyword  
   CQCHKPT command [167](#)  
 system logging  
   status [617](#)  
 system messages  
   CHECKPOINT command [157](#)

## T

terminal command  
   examples [13](#)  
 terminal security  
   defaults for LU 6.2 devices [39](#)  
   defaults for OTMA [39](#)  
 terminal security defaults [24](#)  
 time stamp  
   defined by COMM macro [11](#)  
   in command responses [11](#)  
 TIMEOUT keyword  
   CHANGE command [130](#)  
 TIMEOUT value  
   CHANGE command [146](#)  
 TIMEOVER keyword  
   DISPLAY command  
     description [684](#)  
     examples [685](#)  
 TMEM keyword  
   DEQUEUE command [455](#)  
 TMEMBER keyword  
   DISPLAY command  
     description [685](#)  
     examples [685](#)  
 TMEMBER TPIPE keyword  
   EXIT command [738](#)  
 TPIPE keyword  
   DEQUEUE command [455](#)  
 TPNAME keyword  
   ALLOCATE command [102](#)  
   DEQUEUE command [453](#)  
 TRACE keyword  
   DISPLAY command  
     description [697](#)  
     examples [701](#)  
 trademarks [915](#), [916](#)  
 TRAN keyword  
   /DISPLAY command

TRAN keyword (*continued*)  
 /DISPLAY command (*continued*)  
 QCNT [708](#)  
 ASSIGN command [112](#)  
 DELETE type-2 command [390](#)  
 DEQUEUE command [455](#)  
 DISPLAY command  
 description [707](#)  
 examples [710](#)  
 LOCK command [890](#)  
 MSASSIGN command [908](#)  
 TRANAUTH keyword  
 ERESTART command [725](#)  
 TRANSACTION keyword  
 DISPLAY command  
 with Q keyword [653](#)  
 with SYSID keyword [683](#)  
 TRANSACTION/STEP  
 keyword  
 /DISPLAY command  
 ACT [517](#)  
 TRN= parameter  
 overriding with ERESTART COLDSYS command [725](#)  
 truncated commands [11](#)  
 TSO SPOC  
 command example [14](#)  
 entering [9](#)  
 format [8](#)  
 interface [8](#)  
 issuing  
 commands [8](#)  
 type-1 commands [8](#)  
 type-2 commands [8](#)  
 screen example [8](#)  
 TYPE keyword  
 /DISPLAY command  
 ACT [517](#)  
 type-1  
 command  
 entering [1](#)  
 examples [13](#)  
 format [15](#)  
 responses  
 OM API [12](#)  
 type-2  
 command  
 entering [1](#)  
 command format [20](#)  
 resource types [20](#)  
 responses  
 OM API [12](#)  
 type-2 commands  
 CREATE [175](#), [777](#)  
 DELETE [345](#)  
 EXPORT [741](#)  
 IMPORT DEFN SOURCE(CATALOG) [777](#)  
 IMPORT DEFN SOURCE(REPO | RDDS) [803](#)  
 INITIATE [841](#)

## U

UNLOCK command  
 password [19](#)  
 UOR keyword

UOR keyword (*continued*)  
 CHANGE command  
 ABORT [150](#)  
 COMMIT [150](#)  
 PRTKN [150](#)  
 DISPLAY command  
 description [711](#)  
 examples [713](#)  
 user control block  
 preventing deletion of [111](#)  
 USER keyword  
 ASSIGN command [112](#)  
 BROADCAST command [123](#)  
 CLSDST command [160](#)  
 DEQUEUE command [455](#)  
 DISPLAY command  
 description [715](#)  
 examples [719](#)  
 END command [724](#)  
 ERESTART command [725](#)  
 EXCLUSIVE command [736](#)  
 EXIT command [738](#)  
 USERID keyword  
 DELETE type-2 command [390](#)

## V

VSAM (Virtual Storage Access Method)  
 buffer pool  
 /DISPLAY POOL command [636](#)  
 enhanced buffer pool  
 /DISPLAY POOL command [638](#)  
 VTAM (Virtual Telecommunications Access Method)  
 ACB  
 close [668](#)  
 attached terminals  
 LOOPTEST LINE command [897](#)  
 MSC links  
 checkpoint shutdown [774](#)  
 node  
 close [668](#)  
 EXCLUSIVE NODE command [735](#)  
 IDLE NODE command [775](#)  
 terminal  
 CLSDST command [161](#)  
 VTAM ACB keyword  
 /DISPLAY command  
 ACT [515](#)  
 VTAMPOOL keyword  
 ASSIGN command [112](#)

## X

XRF (Extended Recovery Facility)  
 commands mirrored by the alternate [35](#)  
 commands supported on the alternate [36](#)  
 display screen  
 master terminal [2](#)  
 system status [2](#)  
 XRF takeover [27](#)

## Z

### z/OS

command

entering 1

multiple console support 4

system console

maximum length of command input 5

messages to 13

outstanding reply numbers 5







Product Number: 5635-A06  
5655-DS5  
5655-TM4